

ABB machinery drives

Hardware manual

ACS850-04 drive modules (55 to 200 kW, 60 to 200 hp)



Power and productivity
for a better world™



List of related manuals

Drive hardware manuals and guides	Code (English)
<i>ACS850-04 drive modules (0.37 to 45 kW) hardware manual</i>	3AUA0000045496
<i>ACS850-04 drive modules (55 to 200 kW, 60 to 200 hp) hardware manual</i>	3AUA0000045487
<i>ACS850-04 drive modules (200 to 500 kW, 250 to 600 hp) hardware manual</i>	3AUA0000026234
<i>ACS850-04 drive modules (160 to 560 kW, 200 to 700 hp) hardware manual</i>	3AUA0000081249
<i>ACS850-04 drive modules (0.37 to 45 kW) quick installation guide</i>	3AUA0000045495
<i>ACS850-04 drive modules (55 to 160 kW, 75 to 200 hp) quick installation guide</i>	3AUA0000045488
Drive firmware manuals and guides	
<i>ACS850 standard control program quick start-up guide</i>	3AUA0000045498
<i>ACS850 standard control program firmware manual</i>	3AUA0000045497
<i>ACS850 crane control program supplement (to std ctrl prg)</i>	3AUA0000081708
<i>ACS850-04 drives with SynRM motors (option +N7502) supplement</i>	3AUA0000123521
Option manuals and guides	
<i>ACS850 Common DC configuration for ACS850-04 drives application guide</i>	3AUA0000073108
<i>ATEX-certified Safe disconnection function for ACS850 drives (+Q971) application guide</i>	3AUA0000074343
<i>Safe torque off function for ACS850 and ACQ810 drives application guide</i>	3AFE68929814
<i>Application programming for ACS850 and ACQ810 drives application guide</i>	3AUA0000078664

Manuals and quick guides for I/O extension modules, fieldbus adapters, etc.

You can find manuals and other product documents in PDF format on the Internet. See section [Document library on the Internet](#) on the inside of the back cover. For manuals not available in the Document library, contact your local ABB representative.

ACS850-04 drive modules (55 to 200 kW, 60 to 200 hp)

Hardware manual

3AUA0000045487 Rev C
EN
EFFECTIVE: 2012-06-20

Safety instructions

What this chapter contains

This chapter contains the safety instructions which you must follow when installing, operating and servicing the drive. If ignored, physical injury or death may follow, or damage may occur to the drive, the motor, or driven equipment. Read the safety instructions before you work on the unit.

Use of warnings and notes

There are four types of safety instructions used in this manual:



Dangerous voltage warning warns of high voltage which can cause physical injury and/or damage to the equipment.



General warning warns about conditions, other than those caused by electricity, which can result in physical injury and/or damage to the equipment.



Electrostatic discharge warning warns of electrostatic discharge which can damage the equipment.



Hot surface warning warns of component surfaces that may become hot enough to cause burns if touched.

Installation and maintenance work

These warnings are intended for all who work on the drive, motor cable or motor.



WARNING! Ignoring the following instructions can cause physical injury or death, or damage to the equipment.

Only qualified electricians are allowed to install and maintain the drive.

- Never work on the drive, the motor cable or the motor when input power is applied. After disconnecting the input power, always wait for 5 minutes to let the intermediate circuit capacitors discharge before you start working on the drive, the motor or the motor cable.

Always ensure by measuring with a multimeter (impedance at least 1 Mohm) that:

1. There is no voltage between the drive input phases U1, V1 and W1 and the ground.
 2. There is no voltage between terminals UDC+ and UDC– and the ground.
 3. There is no voltage between terminals R+ and R– and the ground.
- Drives controlling a permanent magnet motor: A rotating permanent magnet motor feeds power to the drive causing the drive to become live even when it is stopped and the supply power switched off. Before maintenance work on the drive,
 - disconnect the motor from the drive by using a safety switch
 - prevent the start-up of any other motors in the same mechanical system
 - lock the motor shaft
 - measure that the motor is in fact de-energised, then connect the U2, V2 and W2 terminals of the drive to each other and to the PE.
 - Do not work on the control cables when power is applied to the drive or to the external control circuits. Externally supplied control circuits may carry dangerous voltages even when the input power of the drive is switched off.
 - Do not make any insulation or voltage withstand tests on the drive.
 - Disconnect the internal EMC filter of the drive (for directions, see page 52) if the drive is to be installed on an IT power system (an ungrounded power system or a high resistance grounded [over 30 ohms] power system) or a corner-grounded power system.

Notes:

- Even when the motor is stopped, dangerous voltages are present at the power circuit terminals U1, V1, W1 and U2, V2, W2, and UDC+, UDC–, R+, R–.
- Depending on the external wiring, dangerous voltages (115 V, 220 V or 230 V) may be present on the terminals of the relay output(s) of the drive.
- The drive supports the Safe torque off function. See page 43.



WARNING! Ignoring the following instructions can cause physical injury or death, or damage to the equipment.

- Never attempt to repair a malfunctioning drive; contact your local ABB representative or Authorized Service Center.
- Make sure that dust from drilling does not enter the drive during the installation. Electrically conductive dust inside the drive may cause damage or lead to malfunction.
- Ensure sufficient cooling.



WARNING! The printed circuit boards contain components sensitive to electrostatic discharge. Wear a grounding wrist band when handling the boards. Do not touch the boards unnecessarily.

Start-up and operation

These warnings are intended for all who plan the operation of the drive, start up or operate the drive.



WARNING! Ignoring the following instructions can cause physical injury or death, or damage to the equipment.

- Before adjusting the drive and putting it into service, make sure that the motor and all driven equipment are suitable for operation throughout the speed range provided by the drive. The drive can be adjusted to operate the motor at speeds above and below the speed provided by connecting the motor directly to the power line.
- Do not activate automatic fault reset functions if dangerous situations can occur. When activated, these functions will reset the drive and resume operation after a fault.
- Do not control the motor with an AC contactor or disconnecting device (disconnecting means); instead, use the control panel or external commands via the I/O board of the drive or a fieldbus adapter. The maximum allowed number of charging cycles of the DC capacitors (i.e. power-ups by applying power) is one per two minutes.
- Drives controlling a permanent magnet motor: Do not run the motor over the rated speed. Motor overspeed leads to overvoltage which may permanently damage the drive.

Notes:

- If an external source for start command is selected and it is ON, the drive will start immediately after an input voltage break or a fault reset unless the drive is configured for 3-wire (pulse) start/stop.
- When the control location is not set to local, the stop key on the control panel will not stop the drive.



WARNING! The surfaces of drive system components (such as the braking resistor, if present) may become hot when the system is in use.

Table of contents

Safety instructions

What this chapter contains	5
Use of warnings and notes	5
Installation and maintenance work	6
Start-up and operation	8

Table of contents

Introduction to this manual

What this chapter contains	15
Compatibility	15
Intended audience	15
Categorization according to the frame size	15
Categorization according to the + code	15
Contents	16
Installation and commissioning flowchart	17
Terms and abbreviations	19

Operation principle and hardware description

What this chapter contains	21
Product overview	21
Layout	21
Power connections and control interfaces	22
Main circuit and operation	23
Type designation key	24

Planning the cabinet assembly

What this chapter contains	27
Cabinet construction	27
Disposition of the devices	27
Grounding of mounting structures	27
Free space requirements	28
Cooling and degrees of protection	29
Preventing the recirculation of hot air	30
Outside the cabinet	30
Inside the cabinet	30
Cabinet heaters	31
EMC requirements	31

Mechanical installation

Contents of the package	33
Moving, unpacking and checking the delivery	33
Before installation	34
Requirements for the installation site	34
Connection to an IT (ungrounded) or a corner-grounded power system	34
Installation procedure	34
Direct surface mounting	34
Braking resistor installation	34

Planning the electrical installation

What this chapter contains	35
Protecting the motor insulation and bearings	35
Checking the compatibility of the motor and drive	35
ABB SynRM motors	35
AC induction and permanent magnet synchronous motors	35
Requirements table	37
Additional requirements for explosion-safe (EX) motors	38
Additional requirements for ABB motors of types other than M2_, M3_, M4_, HX_ and AM_	38
Additional requirements for the braking applications	38
Additional requirements for ABB high-output and IP23 motors	38
Additional requirements for non-ABB high-output and IP23 motors	39
Additional data for calculating the rise time and the peak line-to-line voltage	39
Additional note for sine filters	40
Supply connection	40
Supply disconnecting device	41
Europe	41
Other regions	41
Thermal overload and short circuit protection	41
Thermal overload protection	41
Protection against short-circuit in motor cable	41
Protection against short-circuit in the supply cable or the drive	41
Operating time of the fuses and circuit breakers	42
Circuit breakers	42
Motor thermal protection	42
Ground fault protection	42
Emergency stop devices	42
Safe torque off	43
Selecting the power cables	44
General rules	44
Alternative power cable types	45
Motor cable shield	45
Protecting the relay output contacts and attenuating disturbances in case of inductive loads	46
Selecting the control cables	47
Relay cable	47
Control panel cable	47
Connection of a motor temperature sensor to the drive I/O	47

Routing the cables	47
Control cable ducts	48

Electrical installation

What this chapter contains	49
Removing the cover assembly	49
Checking the insulation of the assembly	51
Drive	51
Supply cable	51
Motor and motor cable	51
Braking resistor assembly	51
Connection to an IT (ungrounded) power system	52
Frame size E0: Disconnection of internal EMC filtering (option +E202 included)	52
Frame size E: Disconnection of internal EMC filtering (option +E202 included)	59
Power cable connection	63
Power cable connection diagram	63
Procedure	64
Frame size E0: Screw terminal installation	64
Frame size E: Cable lug installation (16 to 70 mm ² [AWG6 to AWG2/0] cables)	65
Frame size E: Screw terminal installation (95 to 240 mm ² [AWG3/0 to 400MCM] cables)	66
Grounding the motor cable shield at the motor end	66
DC connection	67
Installation of optional modules	68
Mechanical installation	68
Electrical installation	68
Connecting the control cables	69
Control connections to the JCU control unit	69
Jumpers	70
External power supply for the JCU control unit (XPOW)	70
DI6 (XDI:6) as a thermistor input	71
Drive-to-drive link (XD2D)	72
Safe torque off (XSTO)	73
Grounding and routing the control cables	73
Mounting the clamp plate	74
Routing the control cables	75

Installation checklist

What this chapter contains	77
Checklist	77

Maintenance

What this chapter contains	79
Safety	79
Maintenance intervals	79

Heatsink80
Cooling fan81
Fan replacement (frame E0)81
Fan replacement (frame E)82
Additional cooling fan replacement (frame E0)83
Capacitors83
Reforming83
Changing83
Other maintenance actions84
Transferring the memory unit to a new drive module84

Technical data

What this chapter contains85
Ratings85
400 V AC supply85
480 V AC supply85
500 V AC supply86
Derating86
Ambient temperature derating86
Altitude derating86
Dimensions, weights, noise87
Cooling characteristics87
Supply cable fuses87
AC input (supply) connection88
DC connection88
Motor connection88
JCU control unit88
Efficiency90
Cooling90
Degree of protection90
Ambient conditions91
Materials92
Applicable standards92
CE marking93
Compliance with the European Low Voltage Directive93
Compliance with the European EMC Directive93
Definitions93
Compliance with EN 61800-3:2004, category C293
Compliance with EN 61800-3: 2004, category C394
Compliance with EN 61800-3: 2004, category C494
Compliance with the Machinery Directive94
C-Tick marking94
UL marking94
UL checklist95

Dimension drawings

What this chapter contains97
Drive module, frame size E098

Drive module, frame size E	99
----------------------------------	----

Resistor braking

What this chapter contains	101
Braking choppers and resistors with the drive	101
Braking choppers	101
Braking resistor selection	101
Chopper data / Resistor selection table	102
Resistor installation and wiring	103
Contactor protection of drive	103
Braking circuit commissioning	104

du/dt and common mode filtering

What this chapter contains	105
When is du/dt or common mode filtering required?	105
Filter types	106
du/dt filters	106
Common mode filters	106
Technical data	107
du/dt filters	107
Dimensions and weights	107
Degree of protection	107
Common mode filters	107
Installation	107

Further information

Product and service inquiries	109
Product training	109
Providing feedback on ABB Drives manuals	109
Document library on the Internet	109

Introduction to this manual

What this chapter contains

This chapter describes the intended audience and contents of this manual. It contains a flowchart of steps in checking the delivery, installing and commissioning the drive. The flowchart refers to chapters/sections in this manual and other manuals.

Compatibility

The manual is compatible with ACS850-04 drive modules of frame sizes E0 and E.

Intended audience

This manual is intended for people who plan the installation, install, commission, use and service the drive. Read the manual before working on the drive. The reader is expected to know the fundamentals of electricity, wiring, electrical components and electrical schematic symbols.

This manual is written for readers worldwide. Both SI and imperial units are shown wherever appropriate.

Categorization according to the frame size

Some instructions, technical data and dimensional drawings which concern only certain frame sizes are marked with the symbol of the frame size E0 or E. The frame size is marked on the drive designation label. The frame size of each drive type is also indicated in the rating tables in chapter [Technical data](#).

Categorization according to the + code

The instructions, technical data and dimensional drawings which concern only certain optional selections are marked with + codes, e.g. +L500. The options included in the drive can be identified from the + codes visible on the type designation label of the drive. The + code selections are listed in chapter [Operation principle and hardware description](#) under [Type designation key](#).

Contents

The chapters of this manual are briefly described below.

Safety instructions give safety instructions for the installation, commissioning, operation and maintenance of the drive.

Introduction to this manual lists the steps in checking the delivery and installing and commissioning the drive and refers to chapters/sections in this manual and other manuals for particular tasks.

Operation principle and hardware description describes the drive module.

Planning the cabinet assembly guides in planning the installation of the drive module into a user-defined cabinet.

Mechanical installation instructs how to place and mount the drive.

Planning the electrical installation instructs on the motor and cable selection, the protections and the cable routing.

Electrical installation instructs on how to wire the drive.

Installation checklist contains a list for checking the mechanical and electrical installation of the drive.

Maintenance lists periodic maintenance actions along with work instructions.

Technical data contains the technical specifications of the drive, for example, the ratings, sizes, technical requirements and provisions for fulfilling the requirements for CE and other markings.

Dimension drawings contains the dimensional drawings of the drive modules.

Resistor braking describes how to select, protect and wire braking resistors.

du/dt and common mode filtering lists the du/dt and common mode filtering options available for the drive.

Installation and commissioning flowchart

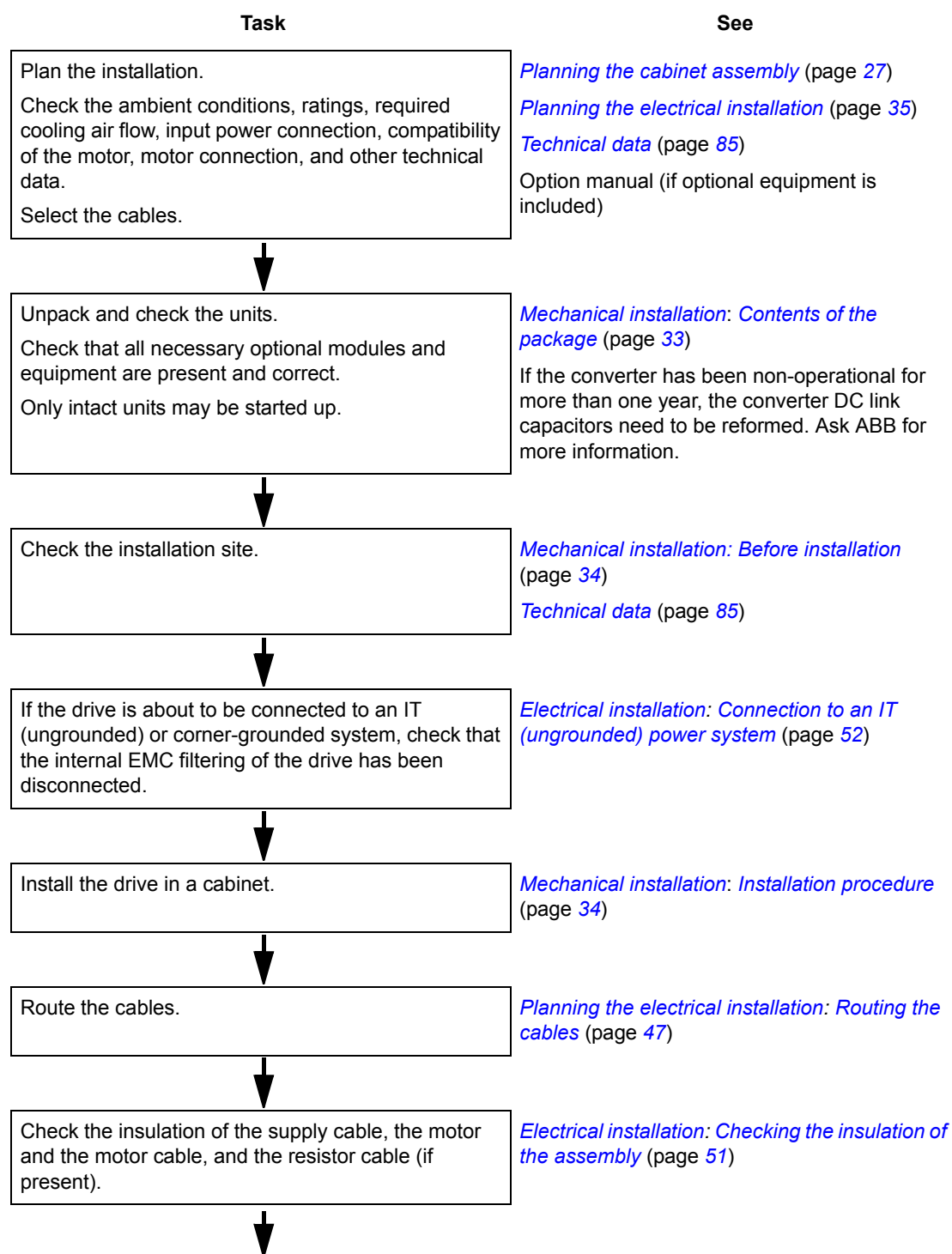

Task	See
Connect the power cables. Connect the control and the auxiliary control cables.	<i>Electrical installation: Power cable connection:</i> (page 63) and <i>Connecting the control cables:</i> (page 69) For optional equipment: <i>Resistor braking</i> (page 101) Manuals for any optional equipment
↓	
Check the installation.	<i>Installation checklist</i> (page 77)
↓	
Commission the drive.	Appropriate <i>Firmware manual</i>
↓	
Commission the braking chopper if required.	<i>Resistor braking</i> (page 101)
↓	
Operating of the drive: start, stop, speed control etc.	Appropriate <i>Firmware manual</i>

Terms and abbreviations

Term/Abbreviation	Explanation
EMC	Electromagnetic compatibility
FIO-01	Optional digital I/O extension module for the ACS850
FIO-11	Optional analog I/O extension module for the ACS850
FIO-21	Optional analog/digital I/O extension module extension for the ACS850
FEN-01	Optional TTL encoder interface for the ACS850
FEN-11	Optional absolute encoder interface for the ACS850
FEN-21	Optional resolver interface for the ACS850
FEN-31	Optional HTL encoder interface for the ACS850
FCAN-01	Optional CANopen fieldbus adapter module for the ACS850
FDNA-01	Optional DeviceNet™ fieldbus adapter module for the ACS850
FECA-01	Optional EtherCAT® fieldbus adapter module
FENA-11	Optional Ethernet/IP™ fieldbus adapter module for the ACS850
FLON-01	Optional LONWORKS® fieldbus adapter module for the ACS850
FSCA-01	Optional Modbus fieldbus adapter module for the ACS850
FPBA-01	Optional PROFIBUS DP fieldbus adapter module for the ACS850
Frame (size)	Size of the drive module. This manual deals with ACS850-04 frames E0 and E. To determine the frame size of a drive module, refer to the drive designation label attached to the drive, or the rating tables in chapter Technical data .
IGBT	Insulated Gate Bipolar Transistor; a voltage-controlled semiconductor type widely used in inverters due to their easy controllability and high switching frequency
I/O	Input/Output
JCU	The control unit of the drive module. The JCU is installed on top of the power unit. The external I/O control signals are connected to the JCU, or optional I/O extensions mounted on it.
JMU	The memory unit attached to the control unit of the drive
PELV	Protective extra low voltage
RFI	Radio-frequency interference
STO	Safe torque off
SynRM	Synchronous reluctance motor

Operation principle and hardware description

What this chapter contains

This chapter describes the construction and operating principle of the drive in short.

Product overview

The ACS850-04 is an IP20 drive module for controlling AC motors, permanent magnet synchronous motors and ABB synchronous reluctance motors (SynRM motors). It is to be installed into a cabinet by the customer.

The ACS850-04 is available in several frame sizes depending on output power. All frame sizes use the same control unit (type JCU). This manual only deals with frame sizes E0 and E.

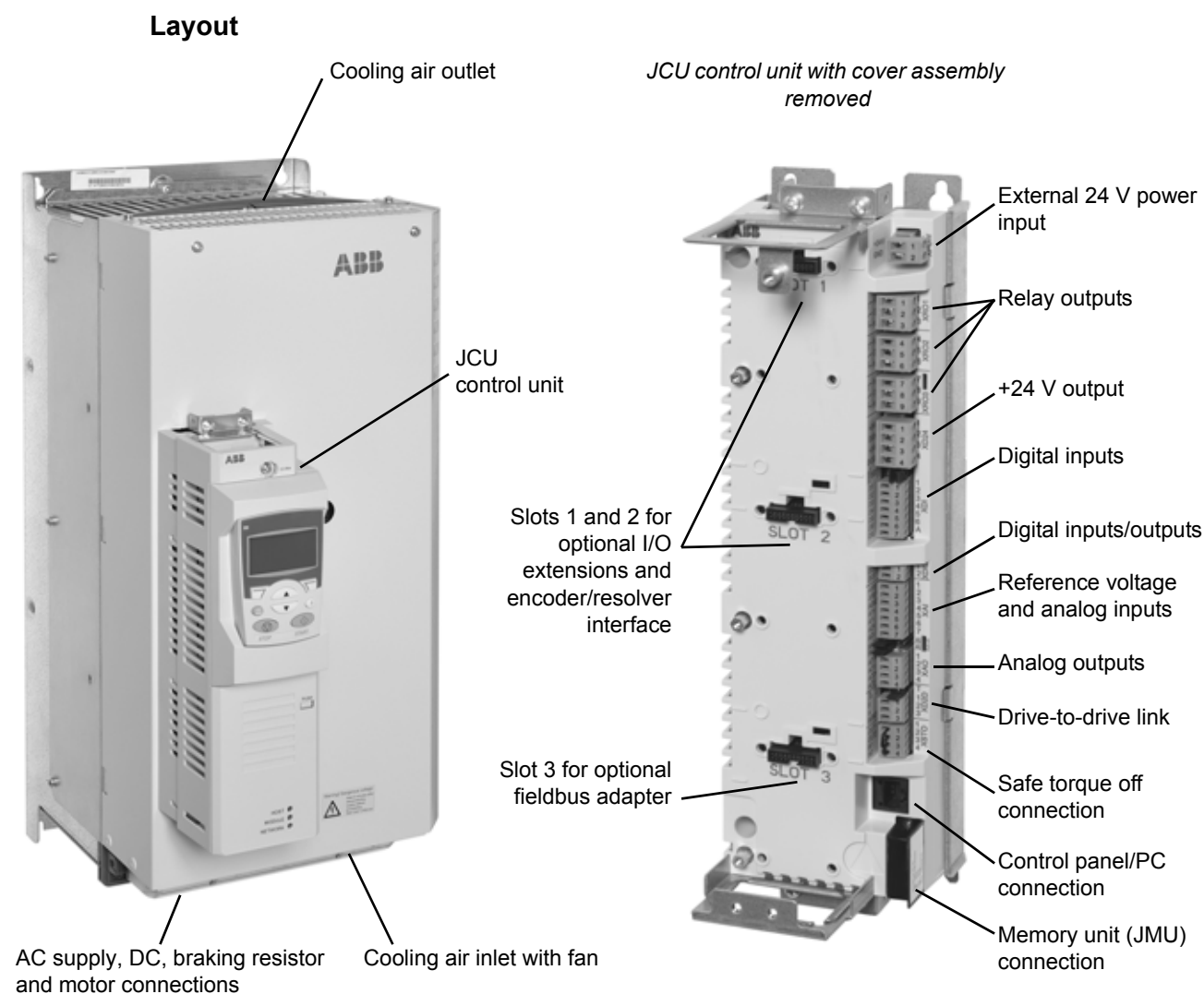

Power connections and control interfaces

The diagram shows the power connections and control interfaces of the drive.

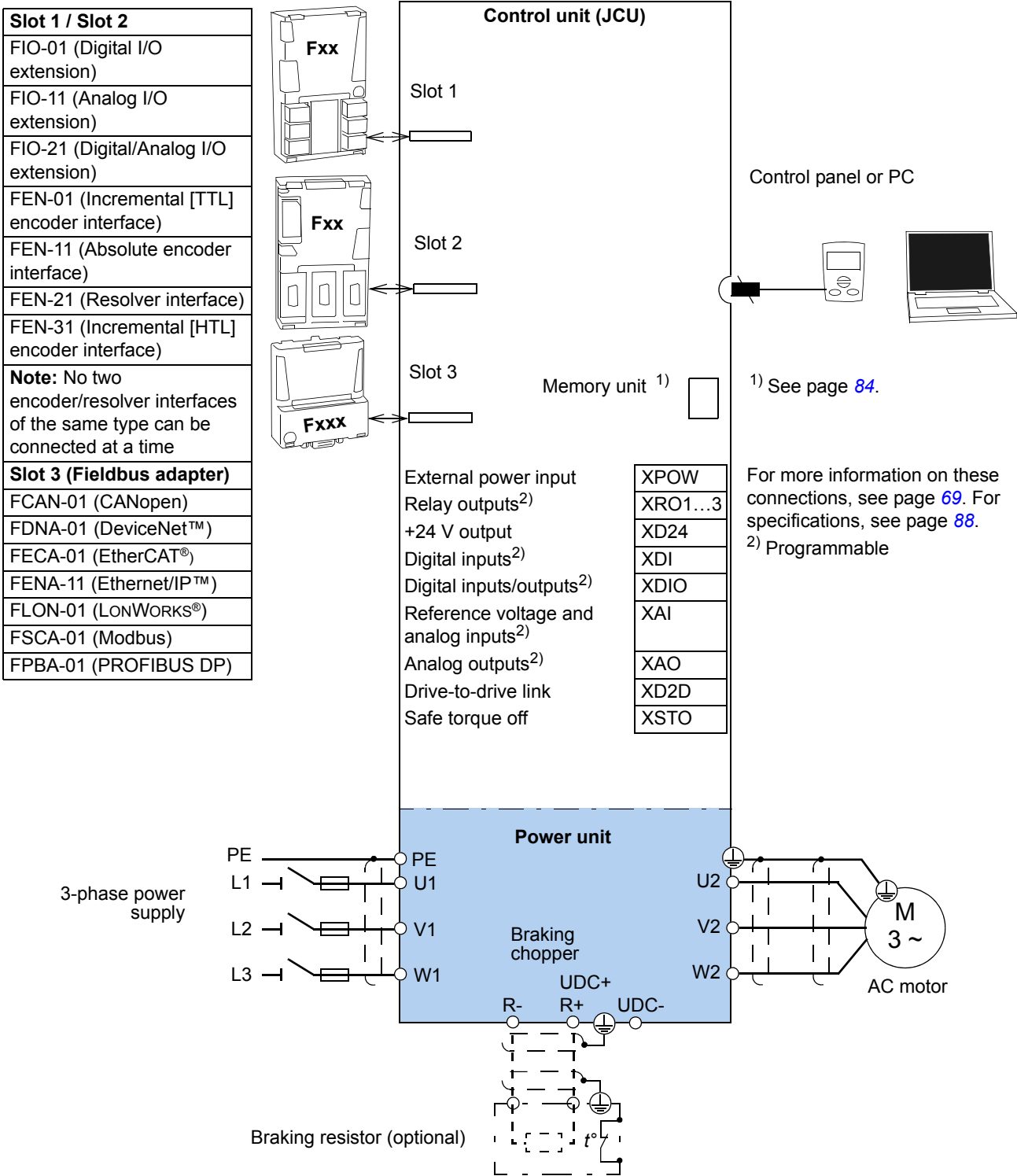

Main circuit and operation

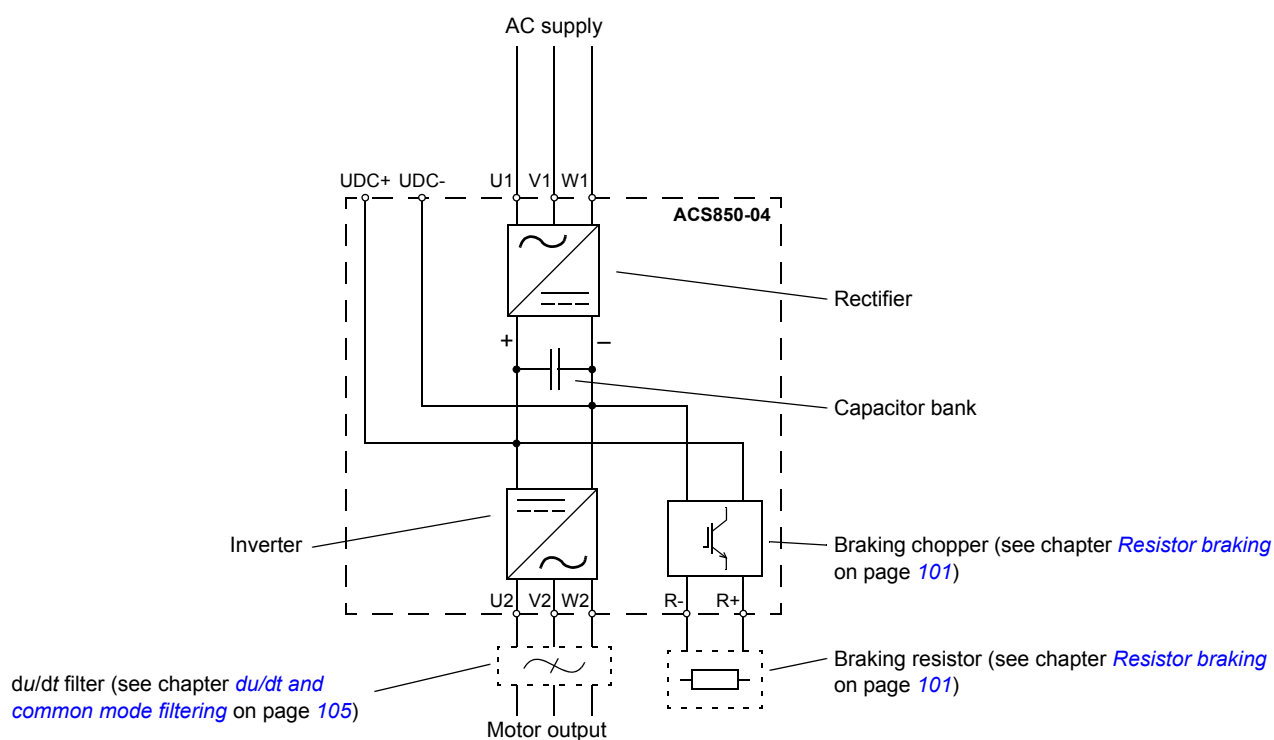

This table describes the operation of the main circuit in short.

Component	Description
Rectifier	Converts the three-phase AC voltage to DC voltage.
Inverter	Converts the DC voltage to AC voltage and vice versa. The motor is controlled by switching the IGBTs of the inverter.
Capacitor bank	Energy storage which stabilizes the intermediate circuit DC voltage.
Braking chopper	Conducts the energy generated by a decelerating motor from the DC bus to a braking resistor. The braking chopper is built in the ACS850-04; braking resistors are external options.
Braking resistor	Dissipates the regenerative energy by converting it to heat.
du/dt filter	See page 105.

Type designation key

The type designation key contains information on the specifications and configuration of the drive. The first digits from left express the basic configuration (for example, ACS850-04-290A-5). The optional selections are given thereafter, preceded by + signs (for example, +L501). The main selections are described below. Not all selections are necessarily available for all types; refer to *ACS850-04 Ordering Information*, available on request.

See also section [Moving, unpacking and checking the delivery](#) on page 33.

Selection	Alternatives	
Product series	ACS850 product series	
Type	04	Drive module. When no options are selected: IP20 (UL Open type), plain front cover, no control panel, no EMC filter, boards with coating, Safe torque off, ACS850 standard control program, <i>Quick installation guide</i> (multilingual), <i>Quick start-up guide</i> (multilingual) and CD containing all manuals
Size	Refer to Technical data: Ratings .	
Voltage range	5	380...500 V AC
+ options		
Resistor braking	D...	+D150: Braking chopper
Filters	E...	+E210: EMC/RFI-filter, C3, 2nd Environment, Unrestricted (Earthed & Unearthed Networks) +E202: EMC/RFI-filter, C2, 1st Environment, Restricted (Earthed Network)
Control panel and control unit mechanics	J...	+0C168: No control unit cover, no control panel +J400: Control panel mounted on drive module front cover +J410: Control panel with door mounting platform kit including 3 m cable +J414: Control panel mounting platform on drive module (no control panel included)
Fieldbus	K...	+K451: FDNA-01 DeviceNet™ fieldbus adapter module +K454: FPBA-01 PROFIBUS DP fieldbus adapter module +K457: FCAN-01 CANopen fieldbus adapter module +K473: FENA-11 Ethernet/IP™ fieldbus adapter module +K458: FSCA-01 Modbus fieldbus adapter module +K452: FLON-01 LONWORKS® fieldbus adapter module +K469: FECA-01 EtherCAT® fieldbus adapter module
I/O extensions and feedback interfaces	L...	+L500: FIO-11 analog I/O extension module +L501: FIO-01 digital I/O extension module +L519: FIO-21 analog/digital I/O extension module +L502: FEN-31 HTL encoder interface module +L516: FEN-21 resolver interface module +L517: FEN-01 TTL encoder interface module +L518: FEN-11 absolute encoder interface module
Programs	N...	+N5050, +N3050: Crane control program. See <i>ACS850 crane control program supplement (to std ctrl prg)</i> (3AUA0000081708 [English]). +N7502: SynRM control program
Specialities	P...	+P904: Extended warranty +Q971: ATEX certified safe disconnection

Selection	Alternatives	
<p>Printed hardware and firmware manuals in specified language (English manuals will be delivered despite of the selection if no manuals in selected language exist)</p>	R...	+R700: English +R701: German +R702: Italian +R703: Dutch +R704: Danish +R705: Swedish +R706: Finnish +R707: French +R708: Spanish +R709: Portuguese +R710: Portuguese spoken in Brazil +R711: Russian +R712: Chinese +R714: Turkish

00579470

Planning the cabinet assembly

What this chapter contains

This chapter guides in planning the installation of a drive module into a user-defined cabinet. The issues discussed are essential for safe and trouble-free use of the drive system.

Note: Please note that the installation must always be designed and made according to applicable local laws and regulations. ABB does not assume any liability whatsoever for any installation which breaches the local laws and/or other regulations.

Cabinet construction

The cabinet frame must be sturdy enough to carry the weight of the drive components, control circuitry and other equipment installed in it.

The cabinet must protect the drive module against contact and meet the requirements for dust and humidity (see chapter [Technical data](#)).

Disposition of the devices

For easy installation and maintenance, a spacious layout is recommended. Sufficient cooling air flow, obligatory clearances, cables and cable support structures all require space.

For layout examples, see section [Cooling and degrees of protection](#) below.

Grounding of mounting structures

Make sure all cross-members or shelves on which drive system components are mounted are properly grounded and the connecting surfaces left unpainted.

Note: Ensure that the components are properly grounded through their fastening points to the installation base.

Free space requirements

The modules can be installed side by side. The dimensions of the drive modules are presented in chapter [Dimension drawings](#). The free space requirements (valid for both frame sizes) are shown below.

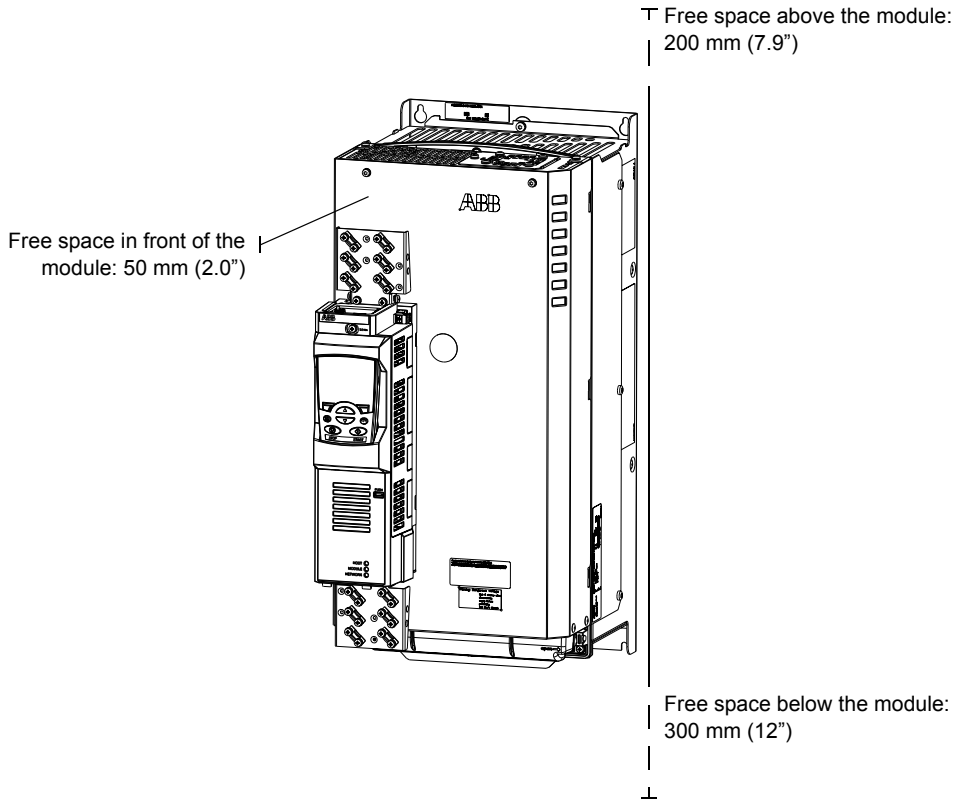

The temperature of the cooling air entering the unit must not exceed the maximum allowed ambient temperature (see [Ambient conditions](#) in chapter [Technical data](#)). Consider this when installing heat-generating components (such as other drives, mains chokes and braking resistors) nearby.

Cooling and degrees of protection

The cabinet must have enough free space for the components to ensure sufficient cooling. Observe the minimum clearances given for each component.

The air inlets and outlets must be equipped with gratings that

- guide the air flow
- protect against contact
- prevent water splashes from entering the cabinet.

The drawing below shows two typical cabinet cooling solutions. The air inlet is at the bottom of the cabinet, while the outlet is at the top, either on the upper part of the door or on the roof.

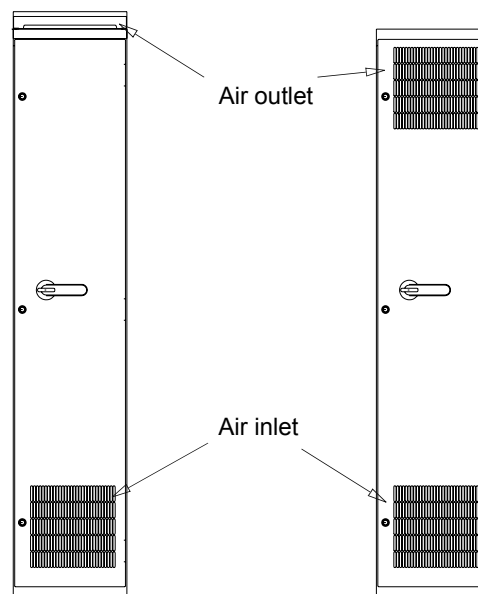

Arrange the cooling air flow through the modules so that the requirements given in chapter *Technical data* are met:

- cooling air flow
Note: The values in *Technical data* apply to continuous nominal load. If the load is less than nominal, less cooling air is required.
- allowed ambient temperature.

Make sure the air inlets and outlets are sufficient in size. Please note that in addition to the power loss of the drive module, the heat dissipated by cables and other additional equipment must also be ventilated.

The internal cooling fans of the modules are usually sufficient to keep the component temperatures low enough in IP22 cabinets.

In IP54 cabinets, thick filter mats are used to prevent water splashes from entering the cabinet. This entails the installation of additional cooling equipment, such as a hot air exhaust fan.

The installation site must be sufficiently ventilated.

Preventing the recirculation of hot air

Typical vertical mounting

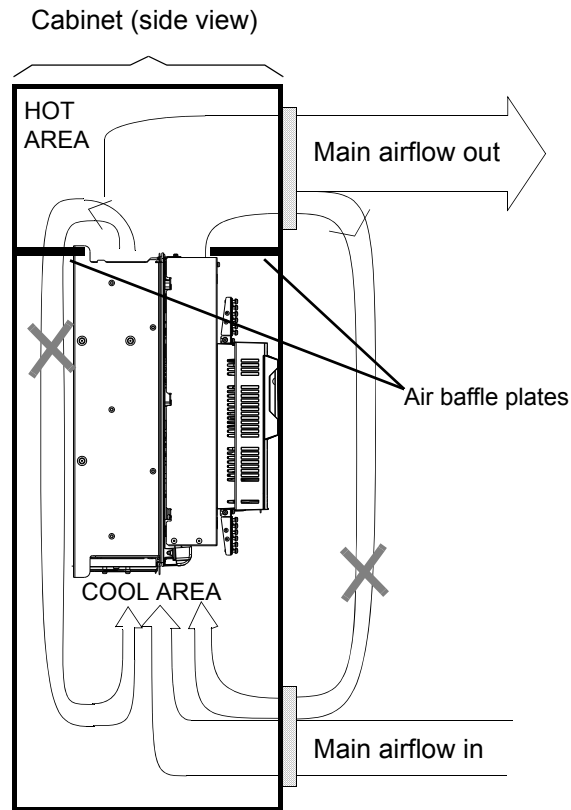

Outside the cabinet

Prevent hot air circulation outside the cabinet by leading the outgoing hot air away from the area where the inlet air to the cabinet is taken. Possible solutions are listed below:

- gratings that guide air flow at the air inlet and outlet
- air inlet and outlet at different sides of the cabinet
- cool air inlet in the lower part of the front door and an extra exhaust fan on the roof of the cabinet.

Inside the cabinet

Prevent hot air circulation inside the cabinet with leak-proof air baffle plates; make sure the air vents of the drive module remain clear. No gaskets are usually required.

Cabinet heaters

Use a cabinet heater if there is a risk of condensation in the cabinet. Although the primary function of the heater is to keep the air dry, it may also be required for heating at low temperatures. When placing the heater, follow the instructions provided by its manufacturer.

EMC requirements

Generally, the fewer and smaller the holes in the cabinet, the better the interference attenuation. The maximum recommended diameter of a hole in galvanic metal contact in the covering cabinet structure is 100 mm. Special attention must be paid to the cooling air inlet and outlet gratings.

The best galvanic connection between the steel panels is achieved by welding them together as no holes are necessary. If welding is not possible, the seams between the panels **are recommended to be left unpainted** and equipped with special conductive EMC strips to provide adequate galvanic connection. Usually, reliable strips are made of flexible silicon mass covered with a metal mesh. The non-tightened touch-contact of the metal surfaces is not sufficient, so a conductive gasket between the surfaces is required. The maximum recommended distance between assembly screws is 100 mm.

Sufficient high-frequency grounding network must be constructed in the cabinet to avoid voltage differences and forming of high-impedance radiator structures. A good high-frequency grounding is made with short flat copper braids for low inductance. One-point high-frequency grounding cannot be used due to the long distances inside the cabinet.

First environment EMC compliance (defined under [Compliance with the European EMC Directive](#) in chapter [Technical data](#)) of the drive requires 360° high frequency grounding of the motor cable shields at their entries. The grounding can be implemented by a knitted wire mesh shielding as shown below.

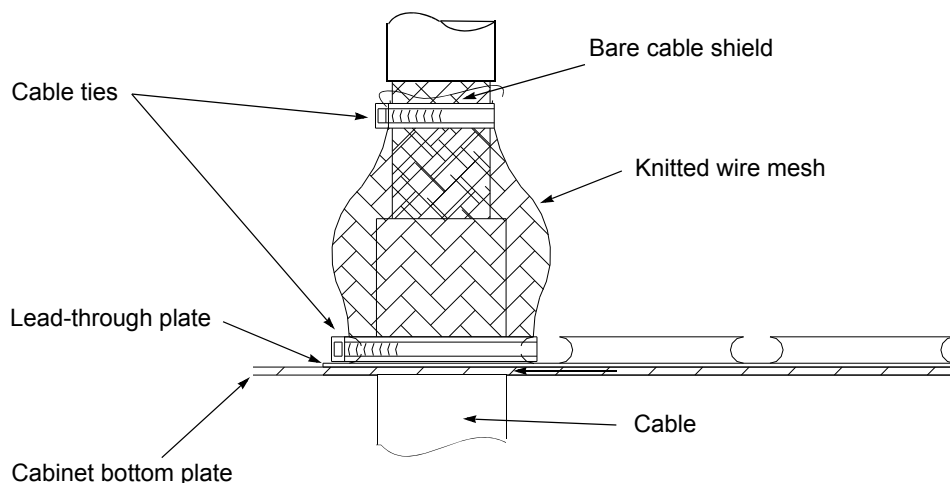

360° high frequency grounding of the control cable shields is recommended at their entries. The shields can be grounded by means of conductive shielding cushions pressed against the cable shield from both directions:

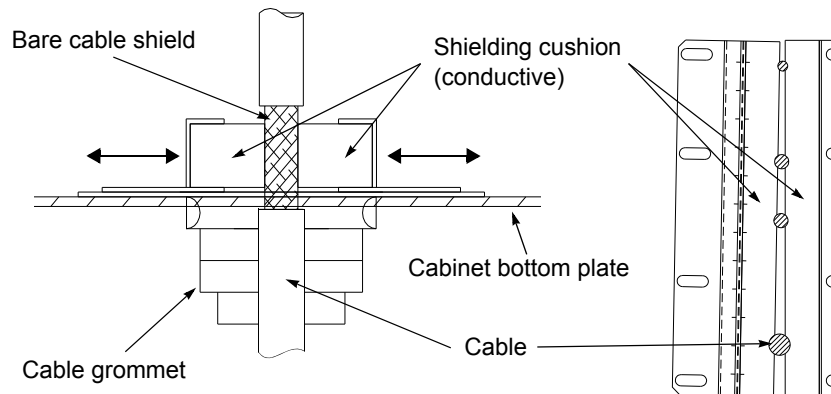

Mechanical installation

Contents of the package

The drive is delivered in a box made of plywood and cardboard. The box contains:

- drive module, with factory-installed options
- one cable clamp plate for control cabling with screws
- screw-type terminal blocks to be attached to the headers on the JCU control unit
- control panel mounting kit if ordered with option code +J410
- printed Quick guides (multilingual), manuals CD, printed manuals if ordered.

Moving, unpacking and checking the delivery

Move the transport package by pallet truck to the installation site. Check that all items shown in the package layout drawings below are present. Check that there are no signs of damage. Check the information on the type designation label of the drive to verify that the unit is of the correct type. The label is located on the left-hand side of the drive module.

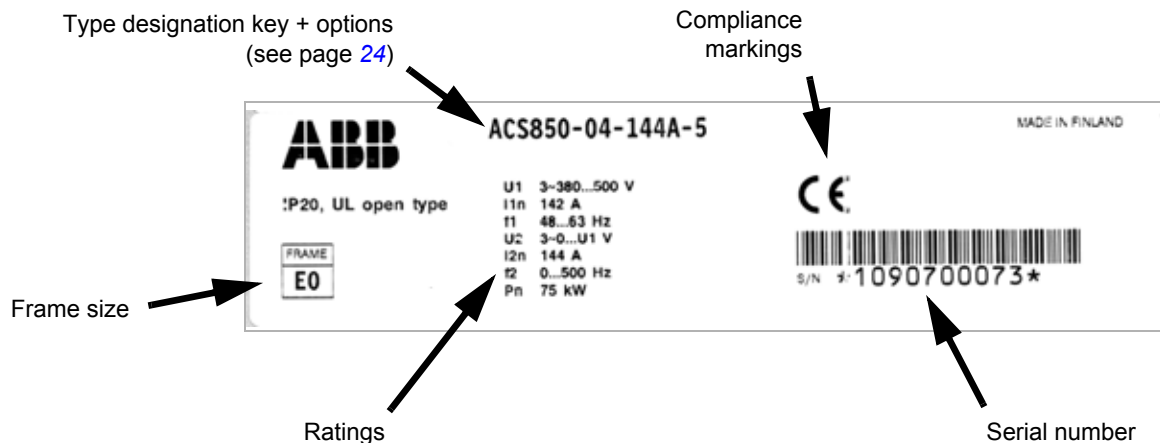

The first digit of the serial number refers to the manufacturing plant. The 2nd and 3rd digit indicate the year of manufacture, while the 4th and 5th digits indicate the week. Digits 6 to 10 are a running integer starting every week at 00001.

Before installation

Check the installation site according to the requirements below. Refer to [Dimension drawings](#) for frame details.

Requirements for the installation site

See chapter [Technical data](#) for the allowed operation conditions of the drive.

The drive is to be mounted in an upright position. The surface that the drive is to be mounted on must be as even as possible, of non-flammable material and strong enough to carry the weight of the drive. The floor/material below the drive must be non-flammable.

Connection to an IT (ungrounded) or a corner-grounded power system

The internal EMC filter must be disconnected if the drive is to be supplied from a corner-grounded power system or an IT power system [an ungrounded power system or a high resistance-grounded (over 30 ohms) power system]. As the procedure involves the removal of drive module covers, it is convenient to perform it before the drive is installed.

See page [52](#) for directions.

Installation procedure

Direct surface mounting

1. Mark the locations for the four holes. The mounting points are shown in [Dimension drawings](#).
2. Fix the screws or bolts to the marked locations.
3. Position the drive onto the screws on the surface. **Note:** Only lift the drive by its lifting holes.
4. Tighten the screws.

Braking resistor installation

See chapter [Resistor braking](#) on page [101](#).

Planning the electrical installation

What this chapter contains

This chapter contains the instructions that you must follow when selecting the motor, cables, protections, cable routing and way of operation for the drive. If the recommendations given by ABB are not followed, the drive may experience problems that the warranty does not cover.

Note: The installation must always be designed and made according to applicable local laws and regulations. ABB does not assume any liability whatsoever for any installation which breaches the local laws and/or other regulations.

Protecting the motor insulation and bearings

The drive employs modern IGBT inverter technology. Regardless of frequency, the drive output comprises pulses of approximately the drive DC bus voltage with a very short rise time. The pulse voltage can almost double at the motor terminals, depending on the attenuation and reflection properties of the motor cable and the terminals. This can cause additional stress on the motor and motor cable insulation.

Modern variable speed drives with their fast rising voltage pulses and high switching frequencies can generate current pulses that flow through the motor bearings. This can gradually erode the bearing races and rolling elements.

Optional du/dt filters protect motor insulation system and reduce bearing currents. Optional common mode filters mainly reduce bearing currents. Insulated N-end (non-drive end) bearings protect the motor bearings.

Checking the compatibility of the motor and drive

Use an asynchronous AC induction motor, a permanent magnet synchronous motor or an ABB synchronous reluctance motor (SynRM, option +N7502) with the drive.

ABB SynRM motors

ABB provides compatible packages of a SynRM motor and a drive, refer to *ACS850-04 drives with SynRM motors (option +N7502) supplement (3AUA0000123521 [English])*.

AC induction and permanent magnet synchronous motors

Several induction motors can be connected to the drive at a time

Only one permanent magnet synchronous motor can be connected to the inverter output. It is recommended to install a safety switch between the permanent magnet synchronous motor and the drive output in order to isolate the motor from the drive during maintenance work on the drive.

Select the motor size and drive type from the rating tables in chapter [Technical data](#) on basis of the AC line voltage and motor load. Use the DriveSize PC tool if you need to tune the selection more in detail.

1. Check that the motor ratings lie within the allowed ranges of the drive control program:
 - motor nominal voltage is in the range of $1/2 \dots 2 \cdot U_N$
 - motor nominal current is $1/6 \dots 2 \cdot I_{Hd}$ of the drive in DTC control and $0 \dots 2 \cdot I_{Hd}$ in scalar control. The control mode is selected by a control program parameter.
2. Check that the motor voltage rating meets the application requirements:

When	... the motor voltage rating should be ...
No resistor braking is in use	U_N
Frequent or long term brake cycles will be used	$1.21 \cdot U_N$

$U_N \hat{=}$ Input voltage of the drive

See chapter [Resistor braking](#) on page 101.

3. Consult the motor manufacturer before using a motor in a drive system where the motor nominal voltage differs from the AC power source voltage.
4. Ensure that the motor insulation system withstands the maximum peak voltage in the motor terminals. See the [Requirements table](#) below for the required motor insulation system and drive filtering.

Example 1: When the supply voltage is 440 V and the drive is operating in the motor mode only, the maximum peak voltage in the motor terminals can be approximated as follows: $440 \text{ V} \cdot 1.35 \cdot 2 = 1190 \text{ V}$. Check that the motor insulation system withstands this voltage.

Requirements table

The following table shows how to select the motor insulation system and when an optional drive du/dt and common mode filters and insulated N-end (non-drive end) motor bearings are required. Ignoring the requirements or improper installation may shorten motor life or damage the motor bearings and voids the warranty.

Motor type	Nominal AC supply voltage	Requirement for	
		Motor insulation system	ABB du/dt and common mode filters, insulated N-end motor bearings
			$P_N < 100$ kW and frame size < IEC 315
			$P_N < 134$ hp and frame size < NEMA 500
ABB motors			
Random-wound M2_, M3_ and M4_	$U_N \leq 500$ V	Standard	-
	500 V < $U_N \leq 600$ V	Standard	+ du/dt
		or	
		Reinforced	-
	600 V < $U_N \leq 690$ V (cable length ≤ 150 m)	Reinforced	+ du/dt
600 V < $U_N \leq 690$ V (cable length > 150 m)	Reinforced	-	
Form-wound HX_ and AM_	380 V < $U_N \leq 690$ V	Standard	n.a.
Old* form-wound HX_ and modular	380 V < $U_N \leq 690$ V	Check with the motor manufacturer.	+ du/dt with voltages over 500 V + N + CMF
Random-wound HX_ and AM_ **	0 V < $U_N \leq 500$ V	Enamelled wire with fiber glass taping	+ N + CMF
	500 V < $U_N \leq 690$ V		+ du/dt + N + CMF
HDP	Consult the motor manufacturer.		
non-ABB motors			
Random-wound and form-wound	$U_N \leq 420$ V	Standard: $\hat{U}_{LL} = 1300$ V	-
	420 V < $U_N \leq 500$ V	Standard: $\hat{U}_{LL} = 1300$ V	+ du/dt
		or	
		Reinforced: $\hat{U}_{LL} = 1600$ V, 0.2 microsecond rise time	-
	500 V < $U_N \leq 600$ V	Reinforced: $\hat{U}_{LL} = 1600$ V	+ du/dt
		or	
		Reinforced: $\hat{U}_{LL} = 1800$ V	-
600 V < $U_N \leq 690$ V	Reinforced: $\hat{U}_{LL} = 1800$ V	+ du/dt	
	Reinforced: $\hat{U}_{LL} = 2000$ V, 0.3 microsecond rise time ***	-	

* manufactured before 1.1.1998

** For motors manufactured before 1.1.1998, check for additional instructions with the motor manufacturer.

*** If the intermediate DC circuit voltage of the drive is increased from the nominal level by resistor braking, check with the motor manufacturer if additional output filters are needed in the applied drive operation range.

The abbreviations used in the table are defined below.

Abbr.	Definition
U_N	Nominal AC line voltage
\hat{U}_{LL}	Peak line-to-line voltage at motor terminals which the motor insulation must withstand
P_N	Motor nominal power
du/dt	du/dt filter at the output of the drive (option +E205)
CMF	Common mode filter (option +E208)
N	N-end bearing: insulated motor non-drive end bearing
n.a.	Motors of this power range are not available as standard units. Consult the motor manufacturer.

Additional requirements for explosion-safe (EX) motors

If you will use an explosion-safe (EX) motor, follow the rules in the requirements table above. In addition, consult the motor manufacturer for any further requirements.

Additional requirements for ABB motors of types other than M2_, M3_, M4_, HX_ and AM_

Use the selection criteria given for non-ABB motors.

Additional requirements for the braking applications

When the motor brakes the machinery, the intermediate circuit DC voltage of the drive increases, the effect being similar to increasing the motor supply voltage by up to 20 percent. Consider this voltage increase when specifying the motor insulation requirements if the motor will be braking a large part of its operation time.

Example: Motor insulation requirement for a 400 V AC line voltage application must be selected as if the drive were supplied with 480 V.

Additional requirements for ABB high-output and IP23 motors

The rated output power of high output motors is higher than what is stated for the particular frame size in EN 50347 (2001). This table shows the requirements for ABB random-wound motor series (for example, M3AA, M3AP and M3BP).

Nominal mains voltage (AC line voltage)	Requirement for	
	Motor insulation system	ABB du/dt and common mode filters, insulated N-end motor bearings
		$P_N < 100$ kW
$U_N \leq 500$ V	Standard	-
500 V $< U_N \leq 600$ V	Standard	+ du/dt
	or	
600 V $< U_N \leq 690$ V	Reinforced	-
	Reinforced	+ du/dt

Additional requirements for non-ABB high-output and IP23 motors

The rated output power of high output motors is higher than what is stated for the particular frame size in EN 50347 (2001). The table below shows the requirements for random-wound and form-wound non-ABB motors.

Nominal AC line voltage	Requirement for	
	Motor insulation system	ABB du/dt filter, insulated N-end bearing and ABB common mode filter
		$P_N < 100$ kW or frame size < IEC 315 $P_N < 134$ hp or frame size < NEMA 500
$U_N \leq 420$ V	Standard: $\hat{U}_{LL} = 1300$ V	+ N or CMF
420 V < $U_N \leq 500$ V	Standard: $\hat{U}_{LL} = 1300$ V	+ du/dt + (N or CMF)
	or Reinforced: $\hat{U}_{LL} = 1600$ V, 0.2 microsecond rise time	+ N or CMF
500 V < $U_N \leq 600$ V	Reinforced: $\hat{U}_{LL} = 1600$ V	+ du/dt + (N or CMF)
	or Reinforced: $\hat{U}_{LL} = 1800$ V	+ N or CMF
600 V < $U_N \leq 690$ V	Reinforced: $\hat{U}_{LL} = 1800$ V	+ du/dt + N
	Reinforced: $\hat{U}_{LL} = 2000$ V, 0.3 microsecond rise time ***	N + CMF

*** If the intermediate DC circuit voltage of the drive is increased from the nominal level by resistor braking, check with the motor manufacturer if additional output filters are needed in the applied drive operation range.

Additional data for calculating the rise time and the peak line-to-line voltage

If you need to calculate the actual peak voltage and voltage rise time considering the actual cable length, proceed as follows:

- Peak line-to line voltage: Read the relative \hat{U}_{LL}/U_N value from the appropriate diagram below and multiply it by the nominal supply voltage (U_N).

- Voltage rise time: Read the relative values \hat{U}_{LL}/U_N and $(du/dt)/U_N$ from the appropriate diagram below. Multiply the values by the nominal supply voltage (U_N) and substitute into equation $t = 0.8 \cdot \hat{U}_{LL}/(du/dt)$.

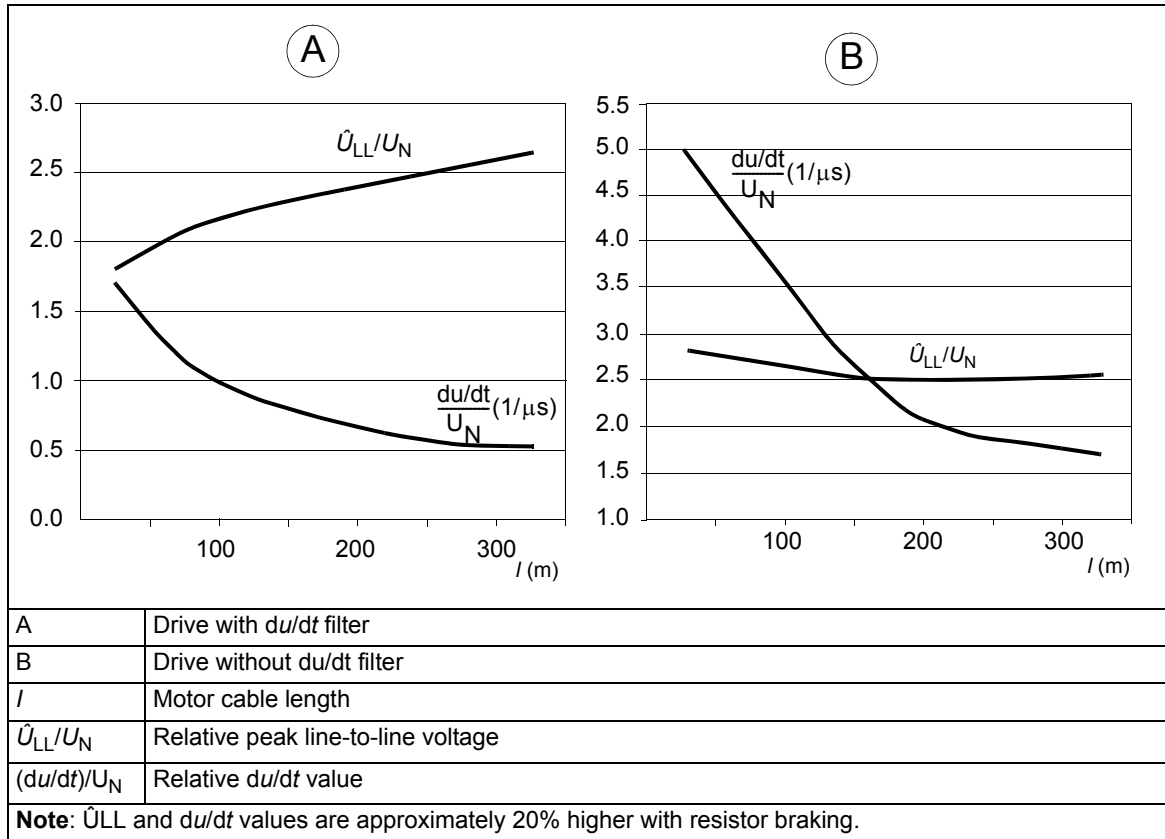

Additional note for sine filters

Sine filters protect the motor insulation system. Therefore, du/dt filter can be replaced with a sine filter. The peak phase-to-phase voltage with the sine filter is approximately $1.5 \cdot U_N$.

Supply connection

Use a fixed connection to the AC power line.



WARNING! As the leakage current of the device typically exceeds 3.5 mA, a fixed installation is required according to IEC 61800-5-1.

Supply disconnecting device

Install a hand-operated input disconnecting device (disconnecting means) between the AC power source and the drive. The disconnecting device must be of a type that can be locked to the open position for installation and maintenance work.

Europe

If the drive is used in an application which must meet the European Union Machinery Directive according to standard EN 60204-1 Safety of Machinery, the disconnecting device must be one of the following types:

- a switch-disconnector of utilization category AC-23B (EN 60947-3)
- a disconnector that has an auxiliary contact that in all cases causes switching devices to break the load circuit before the opening of the main contacts of the disconnector (EN 60947-3)
- a circuit breaker suitable for isolation in accordance with EN 60947-2.

Other regions

The disconnecting means must conform to the applicable safety regulations. For more information, see page [94](#).

Thermal overload and short circuit protection

Thermal overload protection

The drive protects itself and the input and motor cables against thermal overload when the cables are dimensioned according to the nominal current of the drive. No additional thermal protection devices are needed.



WARNING! If the drive is connected to multiple motors, a separate thermal overload switch or a circuit breaker must be used for protecting each cable and motor. These devices may require a separate fuse to cut off the short-circuit current.

Protection against short-circuit in motor cable

The drive protects the motor cable and the motor in a short-circuit situation when the motor cable is dimensioned according to the nominal current of the drive. No additional protection devices are needed.

Protection against short-circuit in the supply cable or the drive

Protect the supply cable with fuses or circuit breakers. Fuse recommendations are given in chapter [Technical data](#). When placed at the distribution board, standard IEC gG fuses or UL type T fuses will protect the input cable in short-circuit situations, restrict drive damage and prevent damage to adjoining equipment in case of a short circuit inside the drive.

Operating time of the fuses and circuit breakers

The operating time depends on the type, the supply network impedance, and the cross-sectional area, material and length of the supply cable. US fuses must be of the “non-time delay” type.

Circuit breakers

The protective characteristics of circuit breakers depend on the supply voltage as well as the type and construction of the breakers. There are also limitations pertaining to the short-circuit capacity of the supply network. Your local ABB representative can help you in selecting the breaker type when the supply network characteristics are known.

Motor thermal protection

According to regulations, the motor must be protected against thermal overload and the current must be switched off when overloading is detected. The drive includes a motor thermal protection function that protects the motor and switches off the current when necessary. Depending on a drive parameter value, the function either monitors a calculated temperature value (based on a motor thermal model) or an actual temperature indication given by motor temperature sensors. The user can tune the thermal model further by feeding in additional motor and load data.

KTY84, PTC or Pt100 sensors can be connected to the ACS850-04. See page [71](#) in this manual, and the appropriate *Firmware manual* for the parameter settings concerning motor thermal protection.

Ground fault protection

The drive is equipped with an internal ground fault protective function to protect the unit against ground faults in the motor and the motor cable. This is not a personal safety or a fire protection feature. The ground fault protective function can be disabled with a parameter, refer to the appropriate *Firmware manual*.

The internal mains filter includes capacitors connected between the main circuit and the frame. These capacitors and long motor cables increase the ground leakage current and may cause fault current circuit breakers to function.

Emergency stop devices

For safety reasons, install the emergency stop devices at each operator control station and at other operating stations where emergency stop may be needed.

Note: Pressing the stop key on the control panel of the drive does not generate an emergency stop of the motor or separate the drive from dangerous potential.

Safe torque off

The drive supports the Safe torque off function (STO) according to standards EN 61800-5-2:2007; EN ISO 13849-1:2008, IEC 61508, IEC 61511:2004 and EN 62061:2005. The function also corresponds to prevention of unexpected start-up of EN 1037.

The Safe torque off function disables the control voltage of the power semiconductors of the drive output stage, thus preventing the inverter from generating the voltage required to rotate the motor (see the diagram below). By using this function, short-time operations (like cleaning) and/or maintenance work on non-electrical parts of the machinery can be performed without switching off the power supply to the drive.

Start up and validate the Safe torque off function according to *Safe torque off function for ACS850 and ACQ810 drives application guide* (3AFE68929814 [English]). The manual includes the safety data for the function.

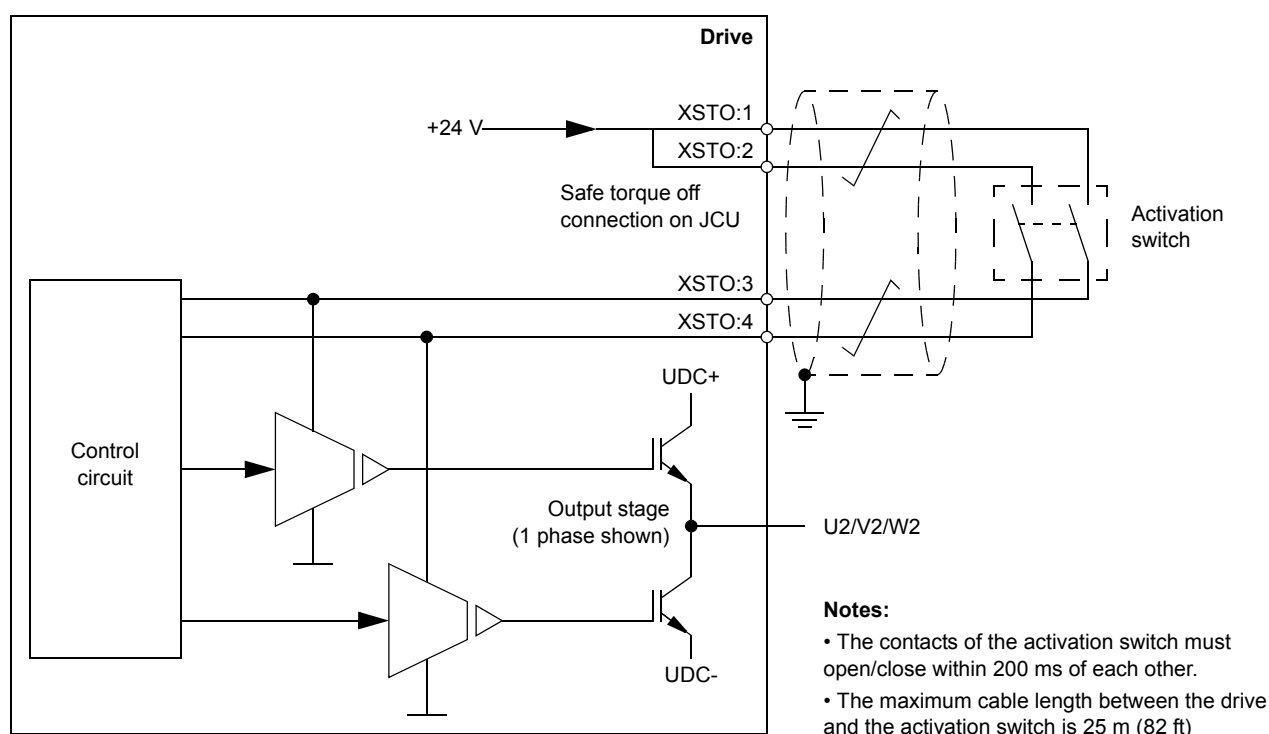

WARNING! The Safe torque off function does not disconnect the voltage of the main and auxiliary circuits from the drive. Therefore maintenance work on electrical parts of the drive or the motor can only be carried out after isolating the drive system from the main supply.

Note: It is not recommended to stop the drive by using the Safe torque off function. If a running drive is stopped by using the function, the drive will trip and stop by coasting. If this causes danger or is not acceptable, the drive and machinery must be stopped using the appropriate stopping mode before using the Safe torque off function. For further information on the function, refer to *Safe torque off function for ACS850 and ACQ810 drives application guide* (3AFE68929814 [English]).

Note concerning permanent magnet motor drives in case of a multiple IGBT power semiconductor failure: In spite of the activation of the Safe torque off function, the drive system can produce an alignment torque which maximally rotates the motor shaft by $180/p$ degrees. p denotes the pole pair number.

Selecting the power cables

General rules

Dimension the supply (input power) and motor cables **according to local regulations**.

- The cable must be able to carry the drive load current. See chapter *Technical data* for the rated currents.
- The cable must be rated for at least 70 °C (US: 75 °C [167 °F]) maximum permissible temperature of conductor in continuous use.
- The inductance and impedance of the PE conductor/cable (grounding wire) must be rated according to permissible touch voltage appearing under fault conditions (so that the fault point voltage will not rise excessively when a ground fault occurs).
- 600 V AC cable is accepted for up to 500 V AC.
- Refer to chapter *Technical data* for EMC requirements.

Symmetrical shielded motor cable must be used (see the figure below) to meet the EMC requirements of the CE and C-tick marks.

A four-conductor system is allowed for input cabling, but shielded symmetrical cable is recommended. To operate as a protective conductor, the shield conductivity must be as follows when the protective conductor is made of the same metal as the phase conductors:

Cross-sectional area of one phase conductor (S)	Minimum cross-sectional area of protective conductor (S _p)
$S \leq 16 \text{ mm}^2$	S
$16 \text{ mm}^2 < S \leq 35 \text{ mm}^2$	16 mm ²
$35 \text{ mm}^2 < S$	S/2

Compared to a four-conductor system, the use of symmetrical shielded cable reduces electromagnetic emission of the whole drive system as well as motor bearing currents and wear.

The motor cable and its PE pigtail (twisted shield) should be kept as short as possible in order to reduce electromagnetic emission, as well as stray currents outside the cable and capacitive current.

Alternative power cable types

Power cable types that can be used with the drive are represented below.

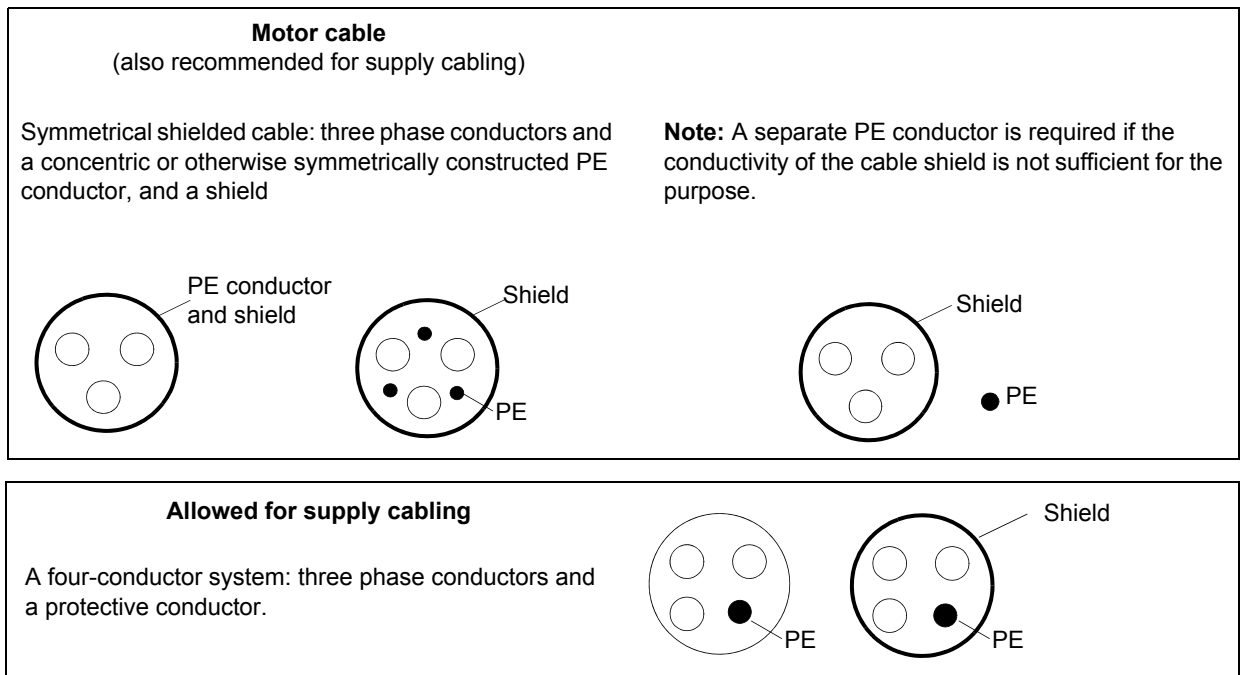

Motor cable shield

To function as a protective conductor, the shield must have the same cross-sectional area as a phase conductor when they are made of the same metal.

To effectively suppress radiated and conducted radio-frequency emissions, the shield conductivity must be at least 1/10 of the phase conductor conductivity. The requirements are easily met with a copper or aluminium shield. The minimum requirement of the motor cable shield of the drive is shown below. It consists of a concentric layer of copper wires with an open helix of copper tape. The better and tighter the shield, the lower the emission level and the bearing currents.

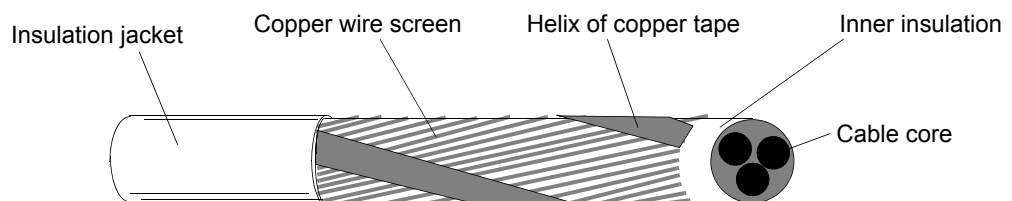

Protecting the relay output contacts and attenuating disturbances in case of inductive loads

Inductive loads (relays, contactors, motors) cause voltage transients when switched off.

The relay output on the drive is protected with varistors (250 V) against overvoltage peaks. In addition, it is highly recommended to equip inductive loads with noise attenuating circuits (varistors, RC filters [AC] or diodes [DC]) in order to minimize the electromagnetic emissions at switch-off. If not suppressed, the disturbances may connect capacitively or inductively to other conductors in the control cable and form a risk of malfunction in other parts of the system.

Install the protective component as close to the inductive load as possible, not at the relay output.

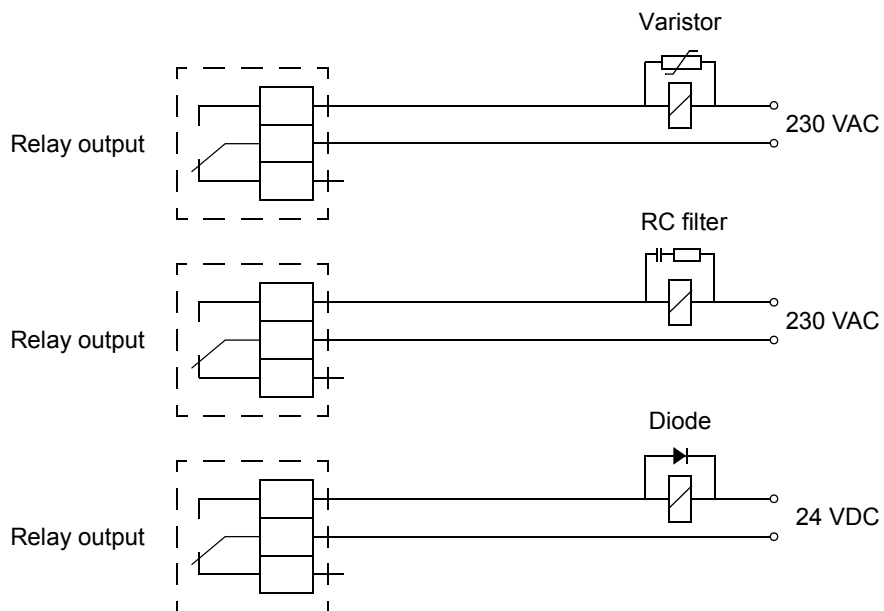

Selecting the control cables

It is recommended that all control cables be shielded.

Double-shielded twisted pair cable is recommended for analogue signals. For pulse encoder cabling, follow the instructions given by the encoder manufacturer. Use one individually-shielded pair for each signal. Do not use a common return for different analogue signals.

Double-shielded cable is the best alternative for low-voltage digital signals but single-shielded twisted multipair cable (Figure *b*) is also usable.

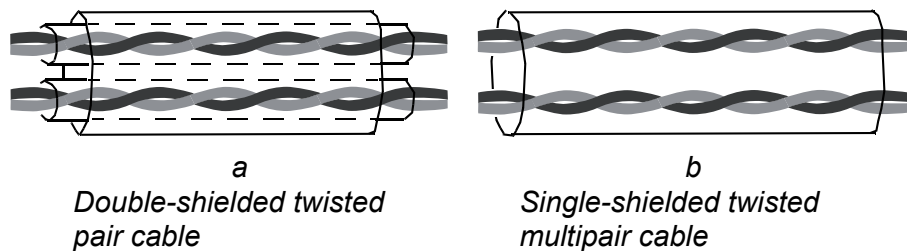

Run analogue and digital signals in separate cables.

Relay-controlled signals, providing their voltage does not exceed 48 V, can be run in the same cables as digital input signals. It is recommended that the relay-controlled signals be run as twisted pairs.

Never mix 24 V DC and 115/230 V AC signals in the same cable.

Relay cable

The cable type with braided metallic screen (e.g. ÖLFLEX by Lapp Kabel, Germany) has been tested and approved by ABB.

Control panel cable

The cable connecting the control panel to the drive must not exceed 3 metres in length. The cable type tested and approved by ABB is used in control panel option kits.

Connection of a motor temperature sensor to the drive I/O

See page [71](#).

Routing the cables

Route the motor cable away from other cable routes. Motor cables of several drives can be run in parallel installed next to each other. It is recommended that the motor cable, input power cable and control cables be installed on separate trays. Avoid long parallel runs of motor cables with other cables in order to decrease electromagnetic interference caused by the rapid changes in the drive output voltage.

Where control cables must cross power cables make sure they are arranged at an angle as near to 90 degrees as possible. Do not run extra cables through the drive.

The cable trays must have good electrical bonding to each other and to the grounding electrodes. Aluminium tray systems can be used to improve local equalizing of potential.

A diagram of the cable routing is below.

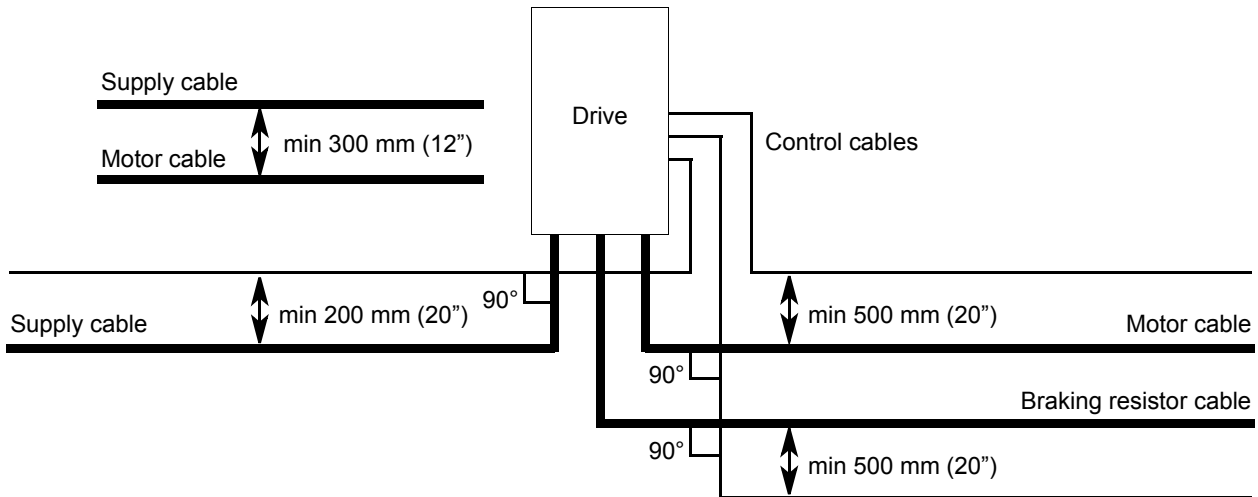

Control cable ducts

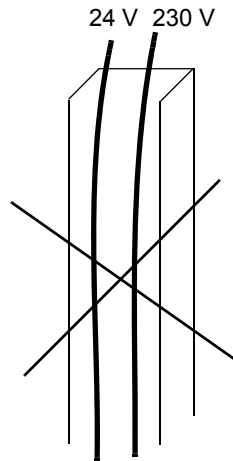

Not allowed unless the 24 V cable is insulated for 230 V or insulated with an insulation sleeving for 230 V.

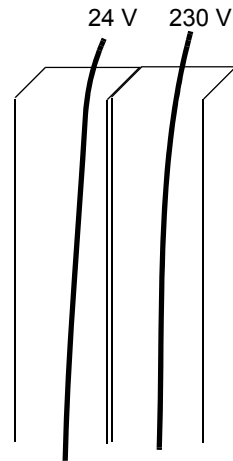

Lead 24 V and 230 V control cables in separate ducts inside the cabinet.

Electrical installation

What this chapter contains

This chapter describes the electrical installation procedure of the drive.



WARNING! The work described in this chapter may only be carried out by a qualified electrician. Follow the [Safety instructions](#) on the first pages of this manual. Ignoring the safety instructions can cause injury or death.

Make sure that the drive is disconnected from the supply (input power) during installation. If the drive is already connected to the supply, wait for 5 minutes after disconnecting the input power.

Removing the cover assembly

The cover assembly needs to be removed before the installation of optional modules and the connection of control cabling. Follow this procedure to remove the cover assembly. The numbers refer to the illustrations below.

- Press the tab (1) slightly with a screwdriver.
- Slide the lower cover plate slightly downwards and pull it out (2).
- Disconnect the panel cable (3) if present.
- Remove the screw (4) at the top of the cover assembly.
- Carefully pull the lower part of the base outwards by the two tabs (5).

Refit the cover in reverse order to the above procedure.

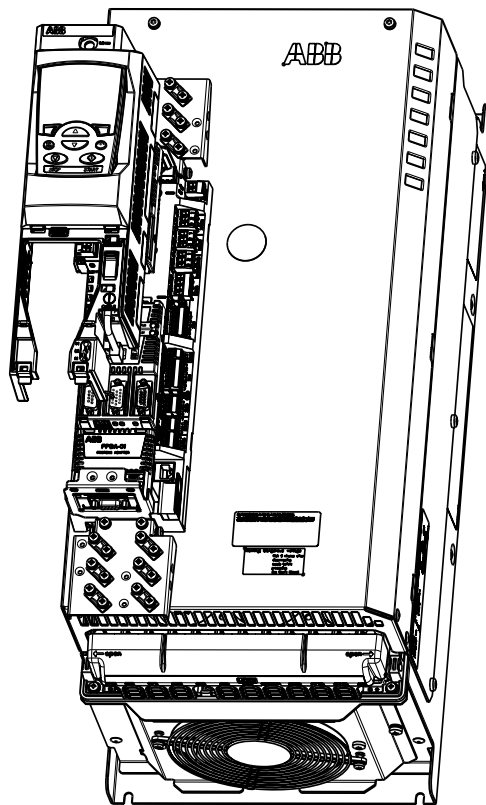
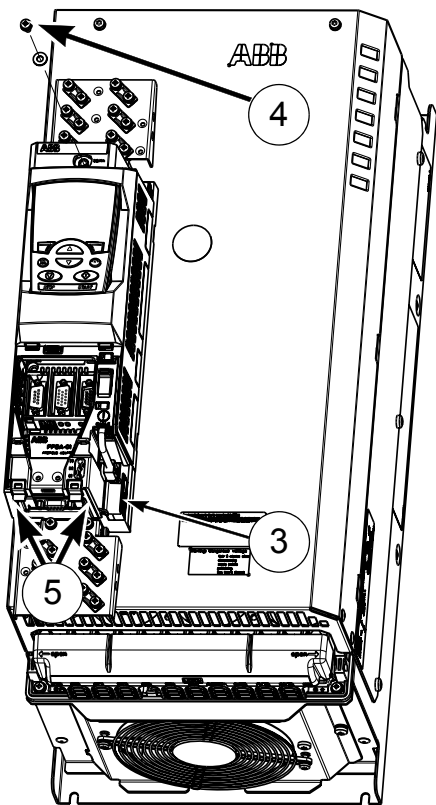
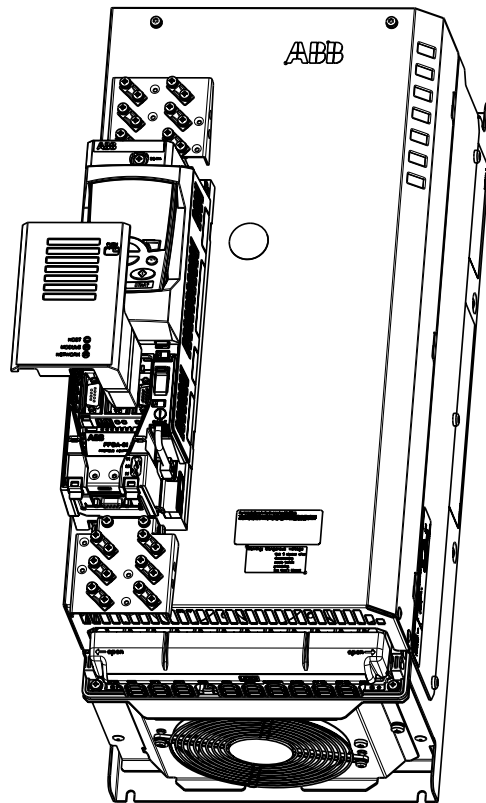
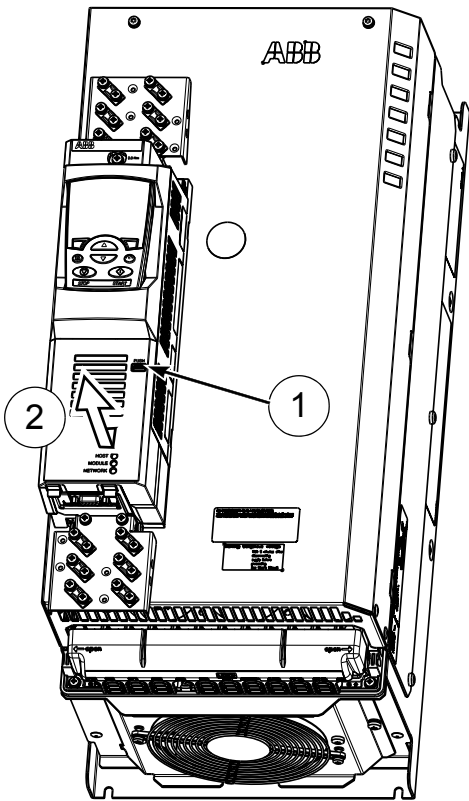

Checking the insulation of the assembly

Drive

Do not make any voltage tolerance or insulation resistance tests on any part of the drive as testing can damage the drive. Every drive has been tested for insulation between the main circuit and the chassis at the factory. Also, there are voltage-limiting circuits inside the drive which cut down the testing voltage automatically.

Supply cable

Check the insulation of the supply (input) cable according to local regulations before connecting to the drive.

Motor and motor cable

Check the insulation of the motor and motor cable as follows:

1. Check that the motor cable is connected to the motor, and disconnected from the drive output terminals U2, V2 and W2.
2. Measure the insulation resistance between each phase conductor and the Protective Earth conductor using a measuring voltage of 500 V DC. The insulation resistance of an ABB motor must exceed 100 Mohm (reference value at 25 °C or 77 °F). For the insulation resistance of other motors, please consult the manufacturer's instructions. **Note:** Moisture inside the motor casing will reduce the insulation resistance. If moisture is suspected, dry the motor and repeat the measurement.

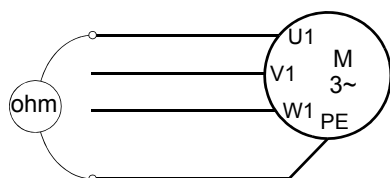

Braking resistor assembly

Check the insulation of the braking resistor assembly (if present) as follows:

1. Check that the resistor cable is connected to the resistor, and disconnected from the drive output terminals R+ and R-.
2. At the drive end, connect the R+ and R- conductors of the resistor cable together. Measure the insulation resistance between the combined conductors and the PE conductor by using a measuring voltage of 1 kV DC. The insulation resistance must be higher than 1 Mohm.

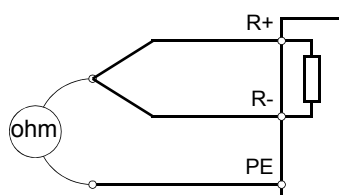

Connection to an IT (ungrounded) power system



WARNING! Before connecting the drive to an IT power system [an ungrounded power system or a high resistance-grounded (over 30 ohms) power system] or a corner-grounded power system, the internal EMC filtering of the drive must be disconnected.

If a drive with its internal EMC filtering connected is installed on an IT system or a corner-grounded system, the drive system will be connected to earth potential through the EMC filter capacitors of the drive. This may cause danger or damage the unit. 1st environment EMC filtering (option +E202) must be disconnected, 2nd environment EMC filtering (option +E210) can be connected.

Frame size E0: Disconnection of internal EMC filtering (option +E202 included)

1. Place the drive module on its back on a level surface.
2. Press the tab slightly with a screwdriver.
3. Slide the lower cover plate slightly downwards and pull it out.

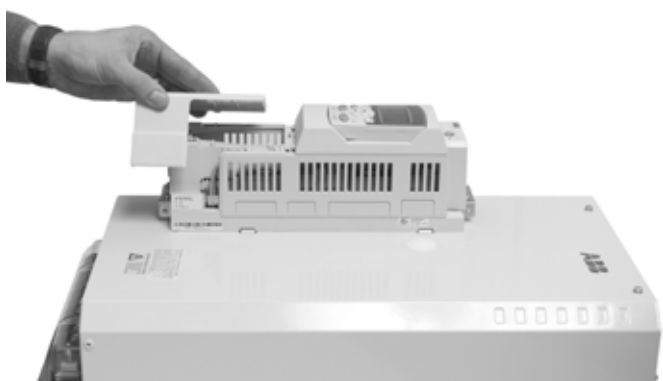
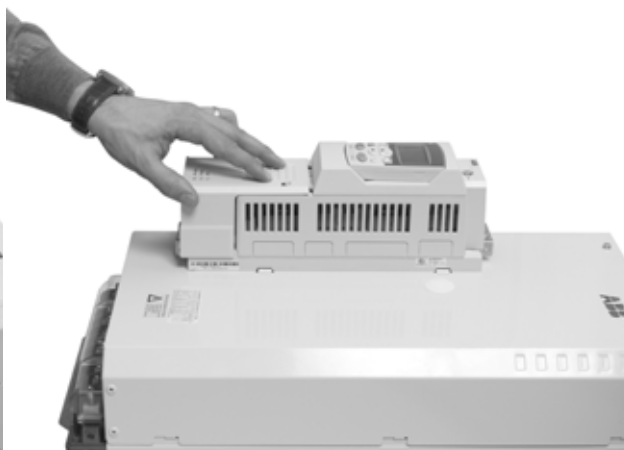

4. Remove the screw at the top of the cover assembly.

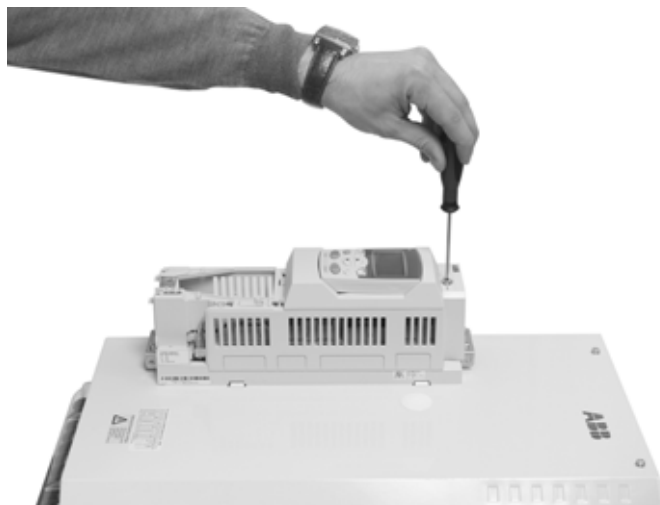

5. Disconnect the panel cable (if present).

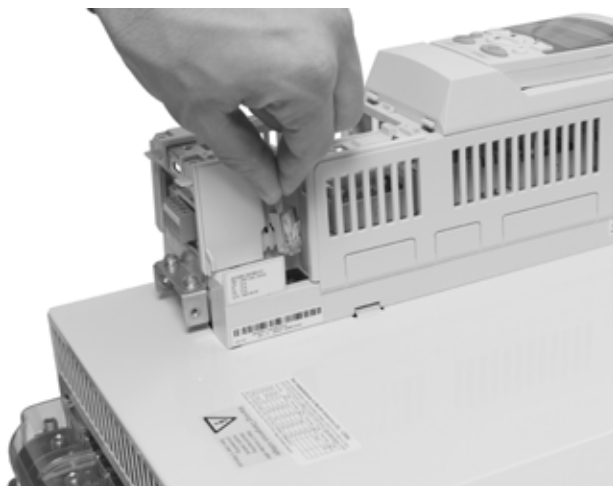

6. Carefully pull the lower part of the base outwards by the two tabs.



7. Lift the cover assembly up.

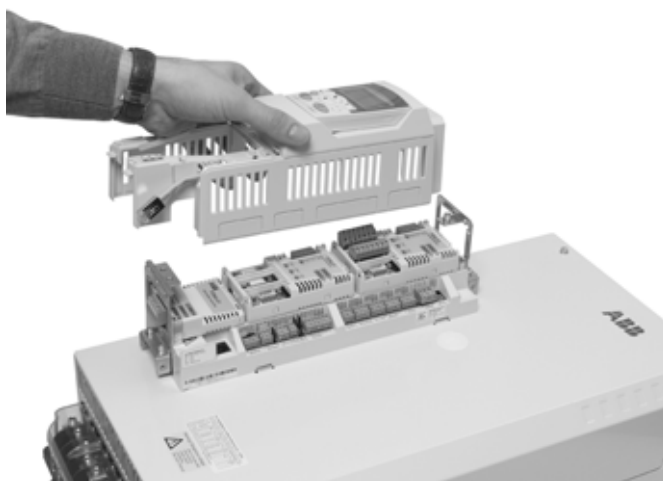

8. Remove the option modules (if any) in options slots 1 and 3.

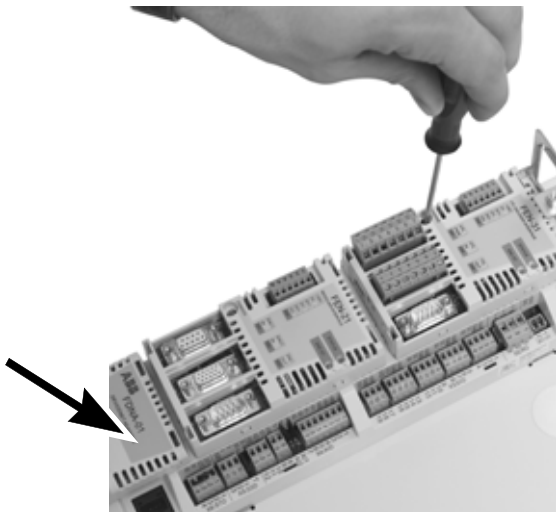

9. Release the two screws holding the JCU control unit.

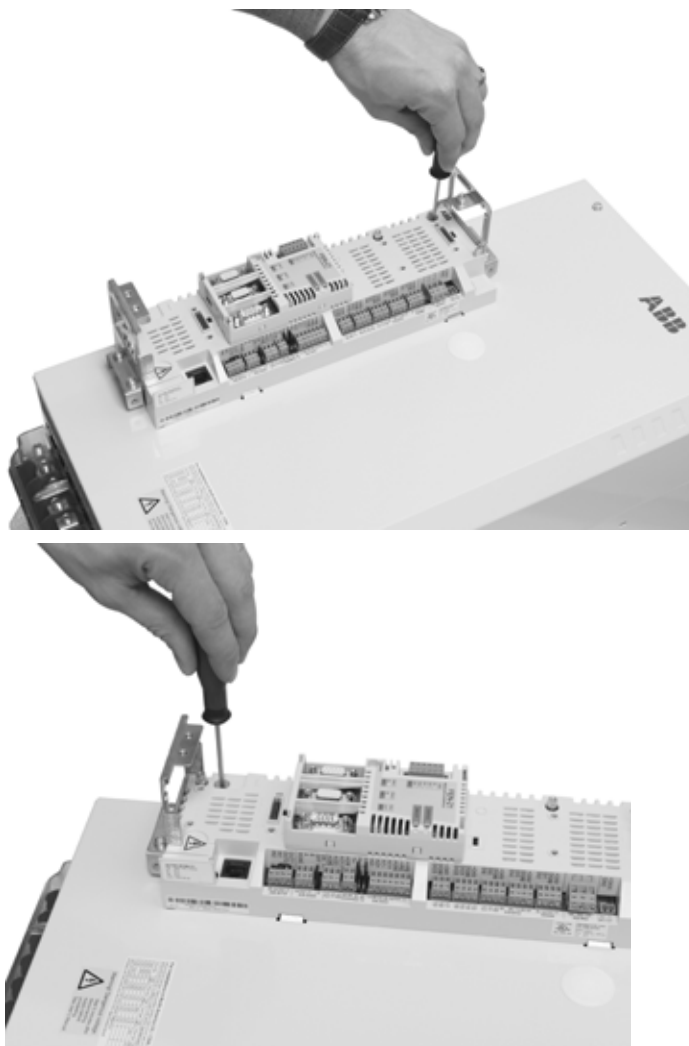

10. Lift the left-hand edge of the JCU control unit until the connector beneath disengages, then move JCU to the left to remove it.

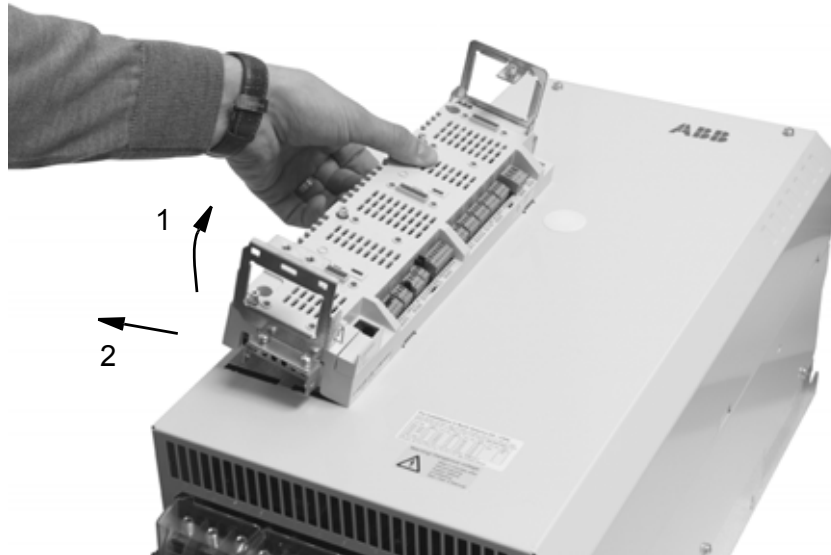

11. Disconnect the two cables coming to the mounting base of the JCU.

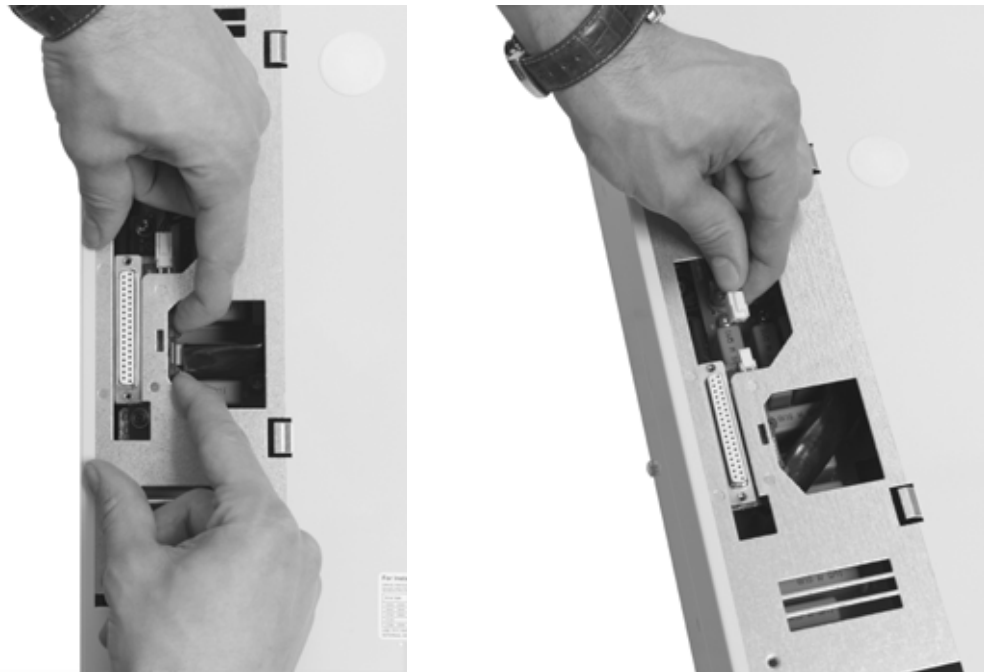

12. Remove the two screws holding the drive module cover.



13. First slide the cover a bit upwards, then lift off the cover.

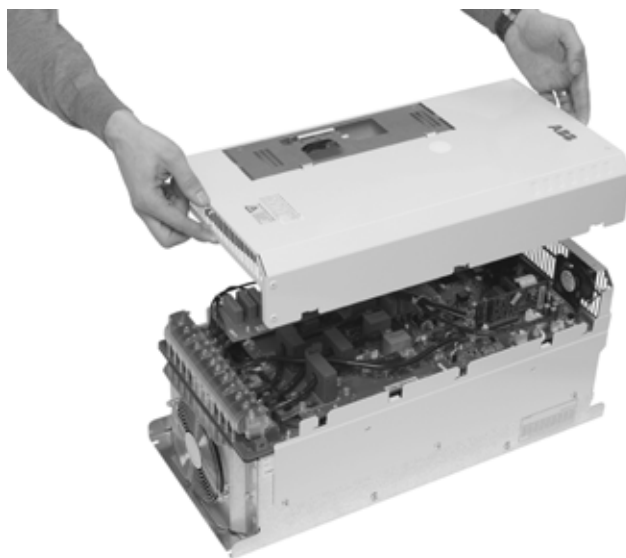

14. Remove the two screws (marked X2 and X3) on top of the RRFC/RVAR circuit board.

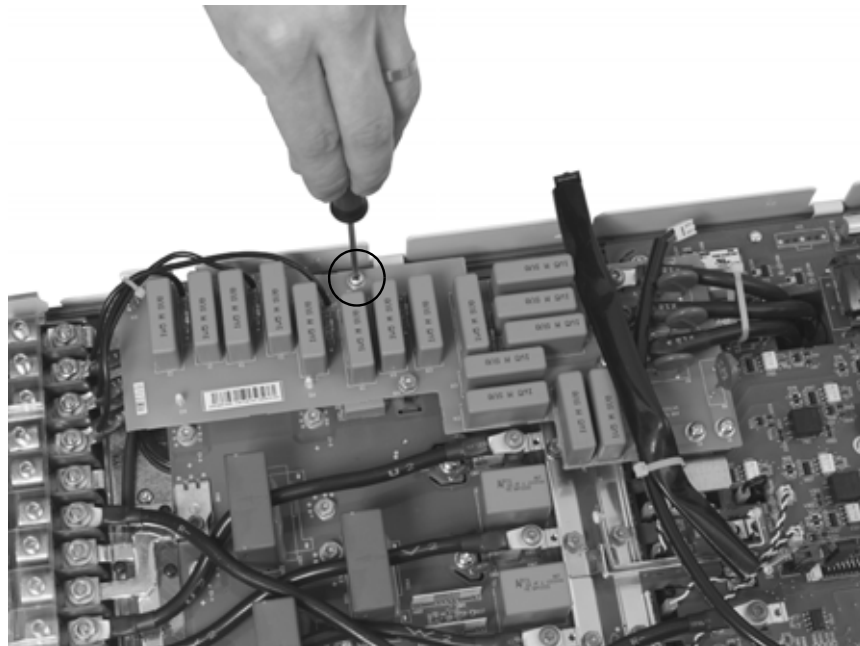
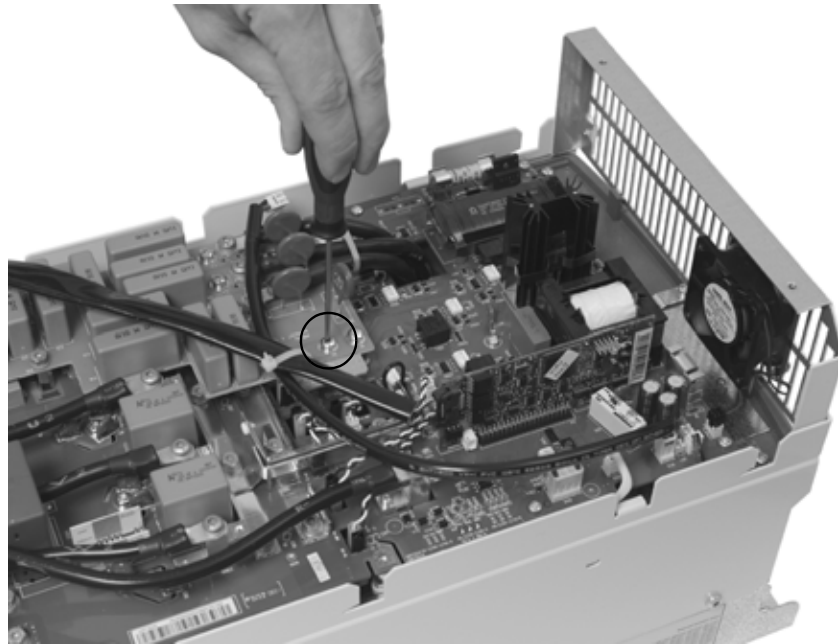

15. Refit the module cover and fasten using the screws removed at step 12.
16. Reconnect the cables that were disconnected at step 11.
17. Refit the JCU control unit.

Frame size E: Disconnection of internal EMC filtering (option +E202 included)

1. Place the drive module on its back on a level surface.
2. Remove the cover assembly and JCU control unit and disconnect the two cables. Follow the same instructions as with frame size E0, steps 1 to 11.
3. Remove the screw in the middle of the air outlet grating.



4. Remove the three screws holding the drive module cover.

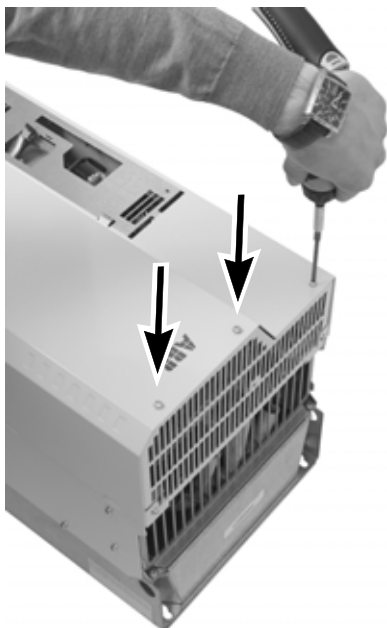

5. First slide the cover a bit upwards, then lift off the cover.



6. Undo the screw connecting the grounding wire to a standoff right next to the EMC filter. Cut off the lug. Discard the screw and the tubular insulator.

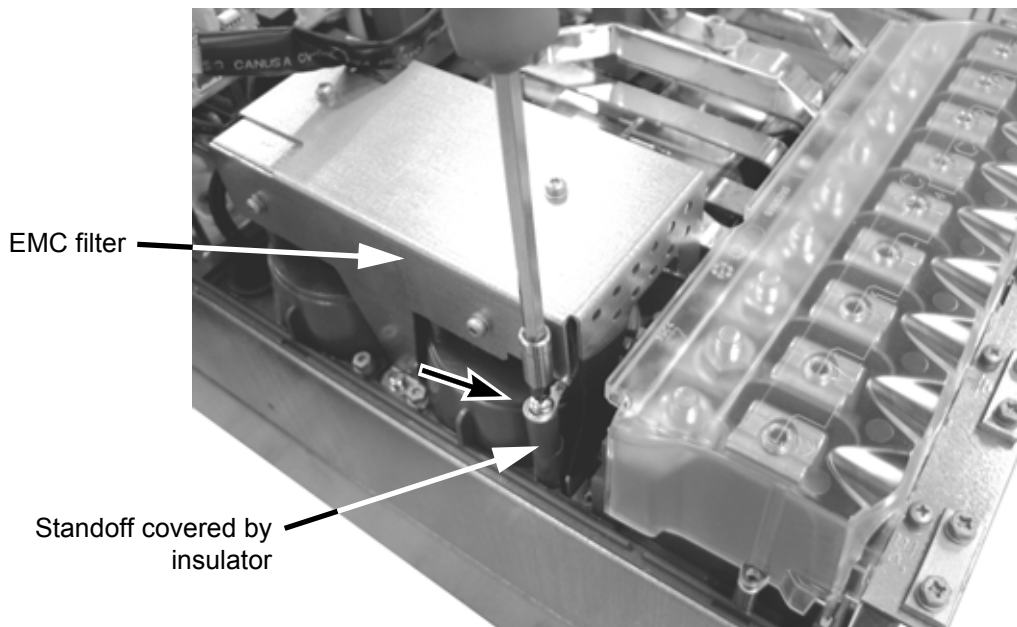

7. Insulate the end of the grounding wire reliably with insulating tape, tube sleeving and a cable tie.

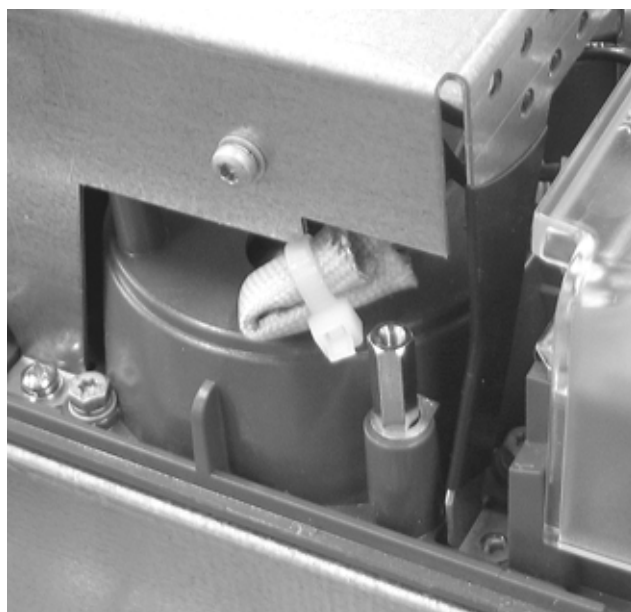

8. Near the top of the module, remove the grounding clip (held by two screws) that connects the varistor board to the module cover. Fasten the removed screws to mount the varistor board.

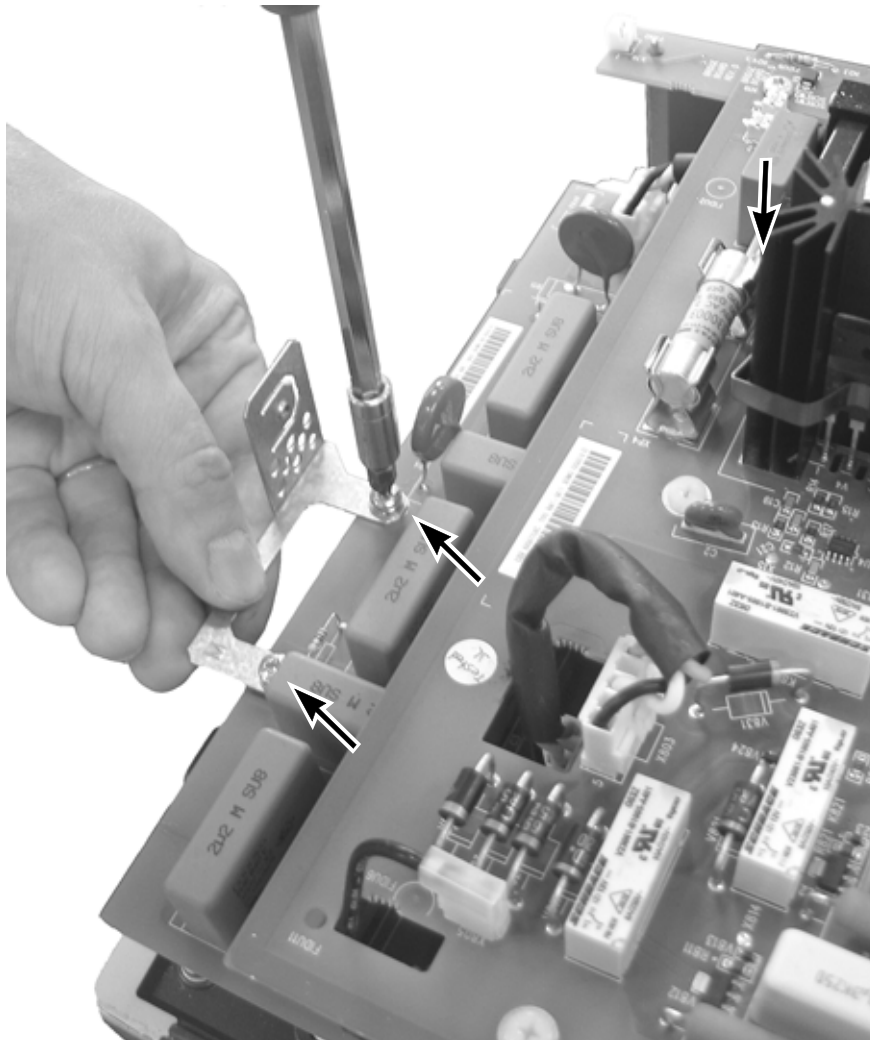

9. Refit the module cover (top edge first) and fasten using the screws removed at step 4. (The screw in the middle of the air outlet grating that was removed at step 3 is no longer needed.)
10. Reconnect the cables that were disconnected at step 2.
11. Refit the JCU control unit.

Power cable connection

Power cable connection diagram

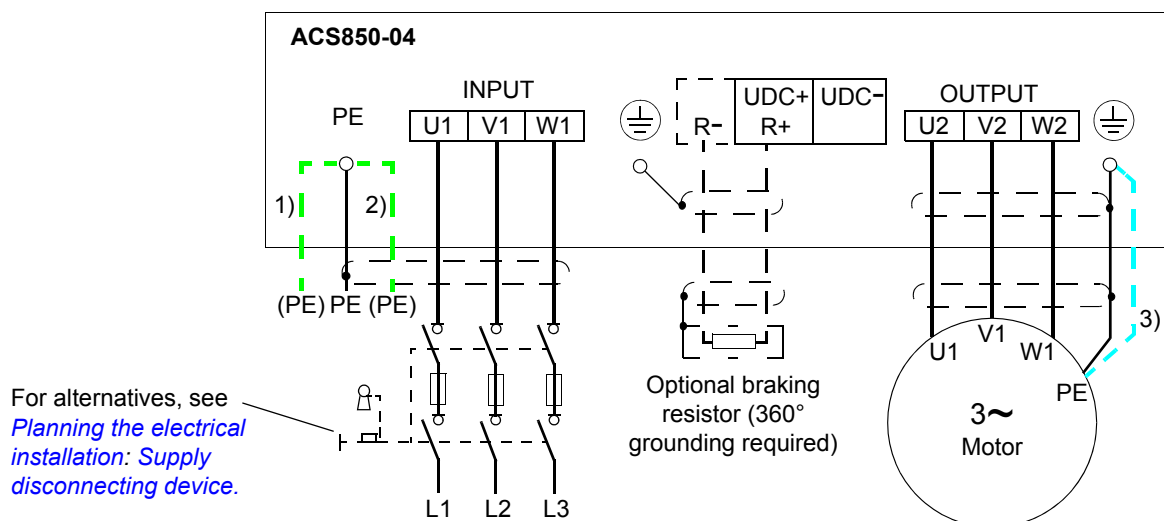

Notes:

- Do not use a non-shielded or asymmetrically-constructed motor cable. It is recommended to use a shielded cable also as an supply (input) cable.
- If shielded supply (input) cable is used (shielded cables are recommended), and the conductivity of the shield is less than 50% of the conductivity of a phase conductor, use a cable with a ground conductor (1) or a separate PE cable (2).
- For motor cabling, use a separate ground cable (3) if the conductivity of the cable shield is less than 50% of the conductivity of a phase conductor and the cable has no symmetrical ground conductors. If there is a symmetrically-constructed ground conductor in the motor cable in addition to the conductive shield, connect it to the ground connectors at both the drive and motor ends.

Procedure

1. Remove the plastic shroud covering the main terminals. Lift up with a screw driver from the corner.
2. Connect the twisted shields of the power cables and separate grounding conductors to the grounding terminals of the drive module.
3. Connect the phase conductors of the supply cable to the U1, V1 and W1 terminals, and the phase conductors of the motor cable to the U2, V2 and W2 terminals. The recommended stripping length is 16 mm (0.63") for frame size E0 and 28 mm (1.1") for frame size E.
4. Secure the cables mechanically outside the drive module.
5. Cut holes for the installed cables into the clear plastic shroud to accommodate the power cables. Press the shroud onto the terminals.

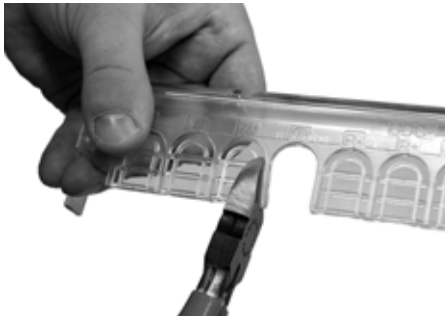

6. Connect the other ends of the power cables. To ensure safety, pay special attention to connection of the grounding conductors.

Frame size E0: Screw terminal installation

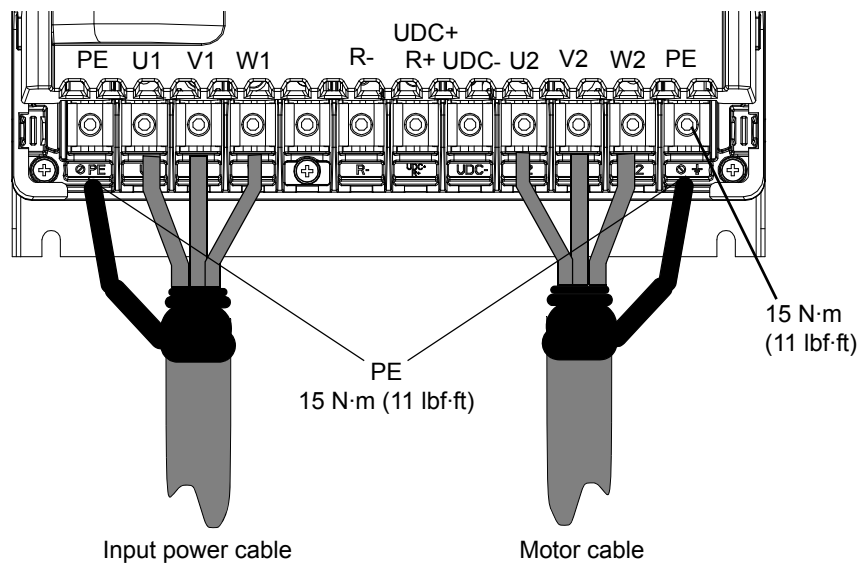

For more information on the terminal wire size capacity, see [Supply cable fuses](#) on page 87.

Frame size E: Cable lug installation
(16 to 70 mm² [AWG6 to AWG2/0] cables)

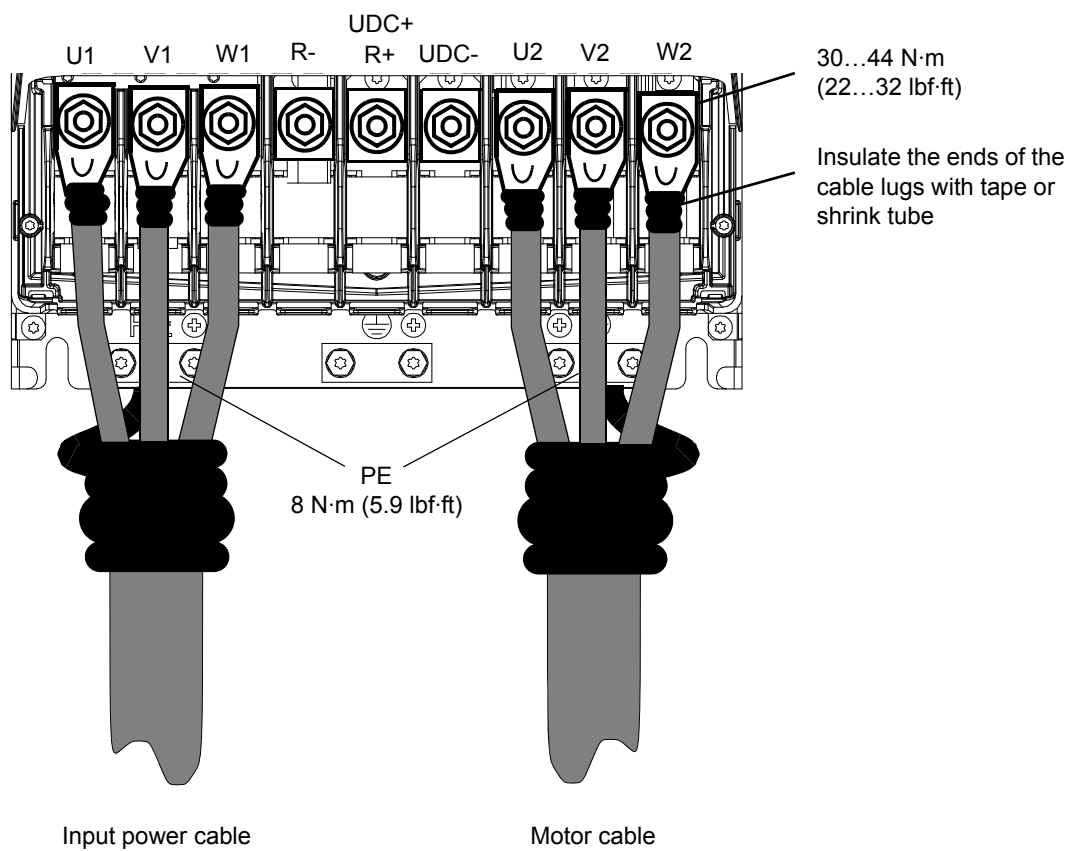

For more information on the terminal wire size capacity, see [Supply cable fuses](#) on page 87.

*Frame size E: Screw terminal installation
(95 to 240 mm² [AWG3/0 to 400MCM] cables)*

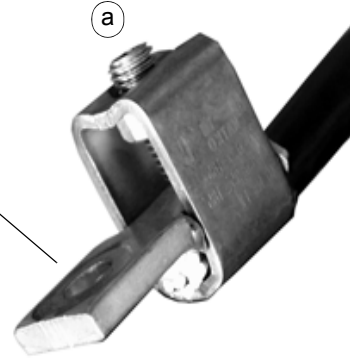
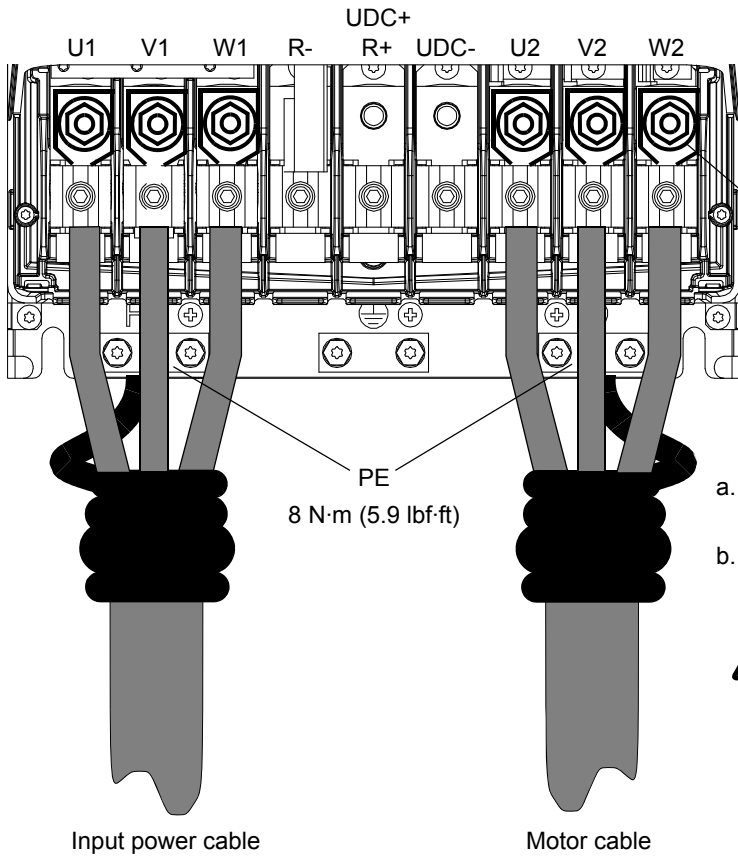

- a. Connect the cable to the terminal. Tighten the Allen screw to 20...40 N·m (15...30 lbf·ft).
- b. Connect the terminal to the drive. Tighten to 30...44 N·m (22...32 lbf·ft).



WARNING! If the wire size is less than 95 mm² (3/0 AWG), a crimp lug must be used. A cable of wire size less than 95 mm² (3/0 AWG) connected to this terminal will loosen and may damage the drive.

Grounding the motor cable shield at the motor end

For minimum radio frequency interference, ground the cable shield 360 degrees at the lead-through of the motor terminal box

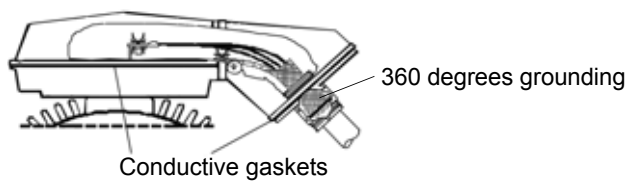

or ground the cable by twisting the shield so that the flattened shield is wider than 1/5 of its length.

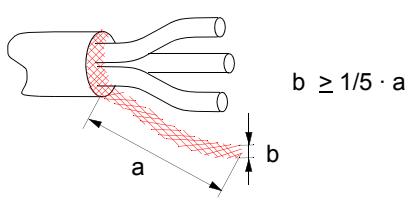

DC connection

The UDC+ and UDC– terminals are intended for common DC configurations of a number of ACS850 drives, allowing regenerative energy from one drive to be utilised by the other drives in motoring mode.

One or more drives are connected to the AC supply depending on the power requirement. In case two or more drives are connected to the AC supply, each AC connection must be equipped with a mains choke (internal, not shown in the diagram below) to ensure even current distribution between the rectifiers. The diagram below shows two configuration examples.

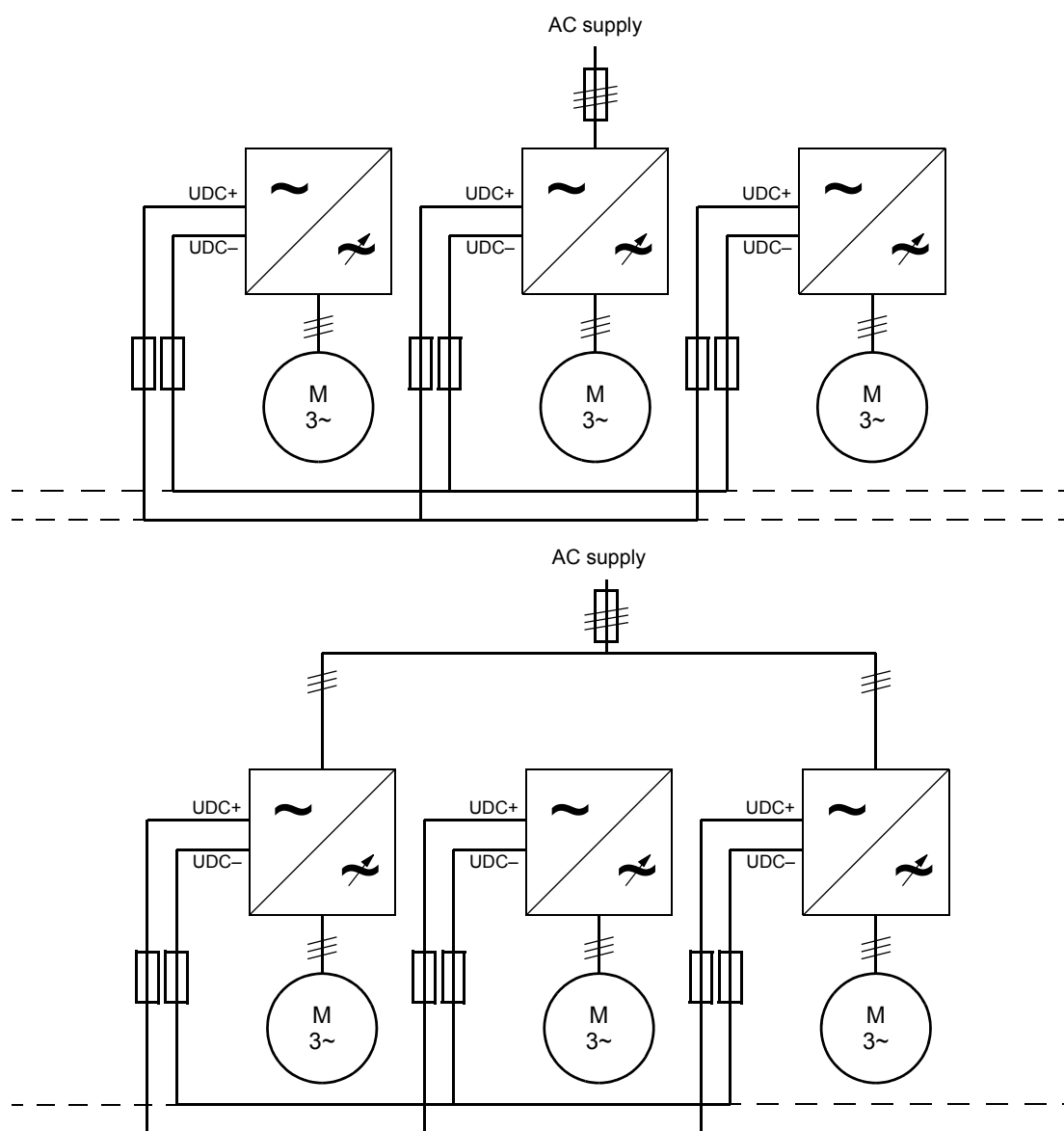

The ratings of the DC connection are given in *Common DC configuration for ACS850-04 drives application guide* (3AUA0000073108 [English]).

Note: When supplying the drive through the DC connection, set parameter 30.08 Cross connection to No to avoid nuisance fault trips. For more information, refer to *Common DC configuration for ACS850-04 drives application guide* (3AUA0000073108 [English])

Installation of optional modules

Optional modules such as fieldbus adapters, I/O extensions and encoder interfaces ordered using option codes (see page 24) are pre-installed at the factory. Instructions for installing additional modules into the slots on the JCU control unit (see page 22 for the available slots) are presented below.

Mechanical installation

- Remove the cover assembly from on the JCU control unit (refer to page 49).
- Remove the protective cover (if present) from the connector of the slot.
- Insert the module carefully into its position on the drive.
- Fasten the screw.

Note: Correct installation of the screw is essential for fulfilling the EMC requirements and for proper operation of the module.

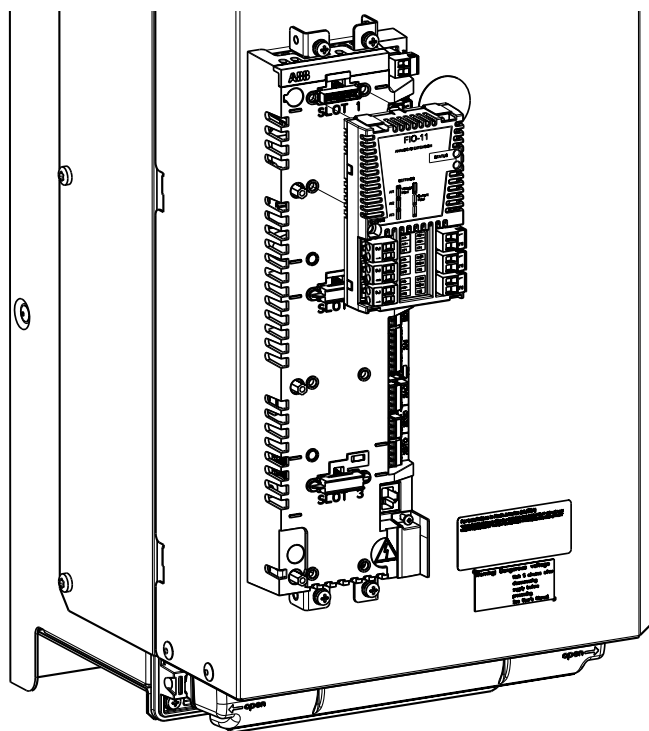

Electrical installation

See section [Grounding and routing the control cables](#) on page 73. See the appropriate option manual for specific installation and wiring instructions.

Connecting the control cables

Control connections to the JCU control unit

Notes:

[Default setting with ACS850 standard control program (Factory macro). See *Firmware manual* for other macros.]

*Total maximum current: 200 mA

The wiring shown is for demonstrative purposes only. Further information of the usage of the connectors and jumpers are given in the text; see also chapter [Technical data](#).

Wire sizes and tightening torques:

XPOW, XRO1, XRO2, XRO3, XD24:
0.5 ... 2.5 mm² (24...12 AWG). Torque: 0.5 N·m (5 lbf·in)

XDI, XDIO, XAI, XAO, XD2D, XSTO:
0.5 ... 1.5 mm² (28...14 AWG). Torque: 0.3 N·m (3 lbf·in)

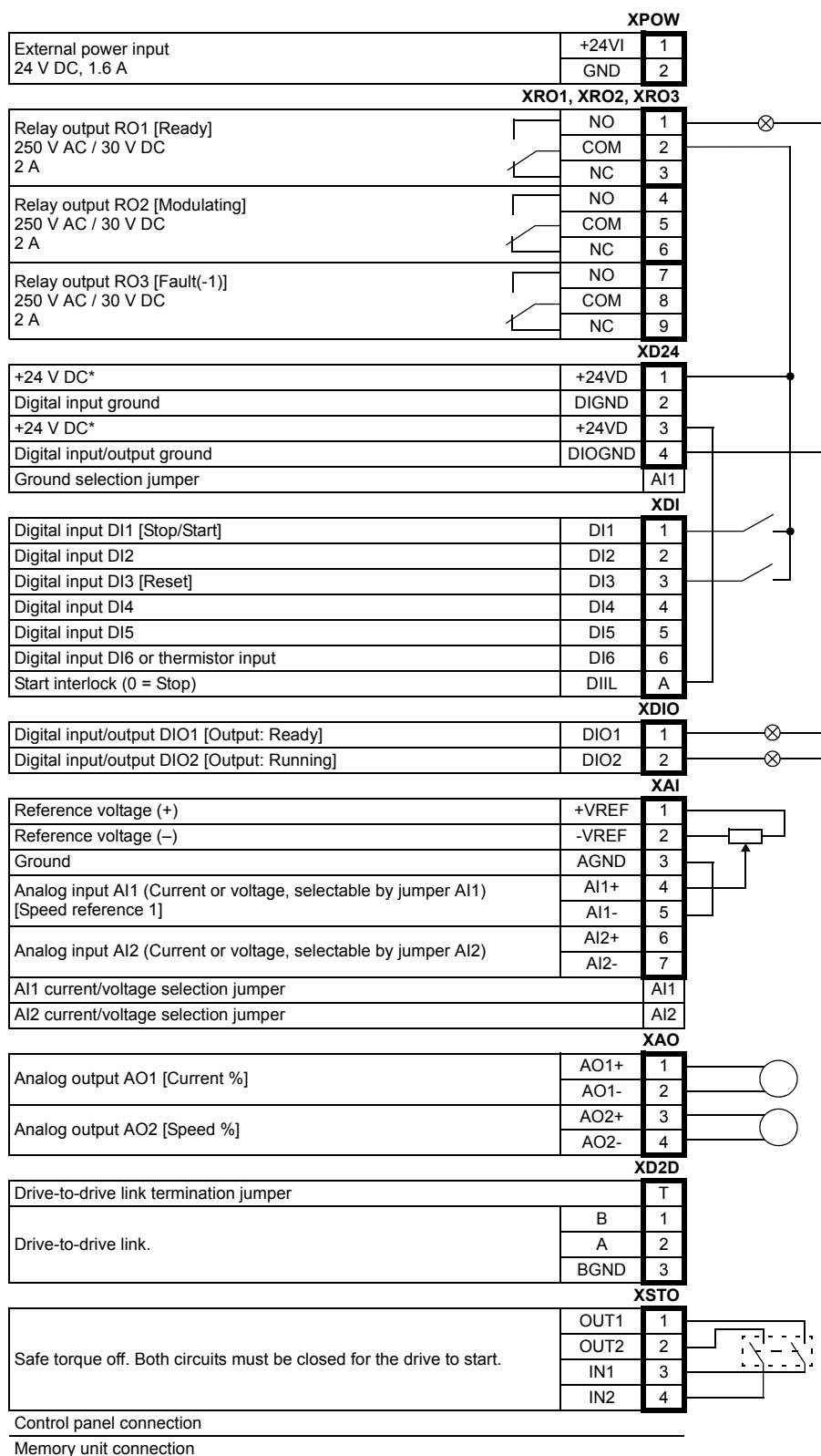
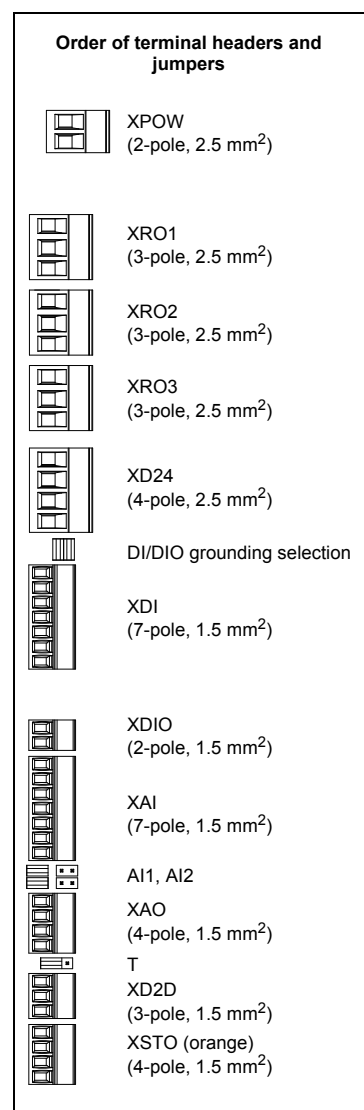

Jumpers

DI/DIO grounding selector (located between XD24 and XDI) – Determines whether the DIGND (ground for digital inputs DI1...DI5) floats, or if it is connected to DIOGND (ground for DI6, DIO1 and DIO2). (See the JCU isolation and grounding diagram on page 90.)

If DIGND floats, the common of digital inputs DI1...DI5 should be connected to XD24:2. The common can be either GND or V_{CC} as DI1...DI5 are of the NPN/PNP type.

DIGND floats

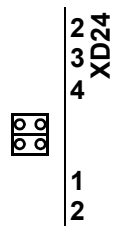

DIGND tied to DIOGND

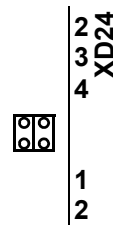

AI1 – Determines whether Analog input AI1 is used as a current or voltage input.

Current

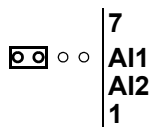

Voltage

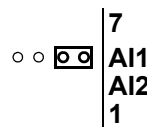

AI2 – Determines whether Analog input AI2 is used as a current or voltage input.

Current

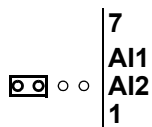

Voltage

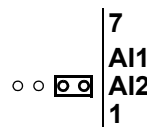

T – Drive-to-drive link termination. Must be set to the ON position when the drive is the last unit on the link.

Termination ON



Termination OFF



External power supply for the JCU control unit (XPOW)

External +24 V (minimum 1.6 A) power supply for the JCU control unit can be connected to terminal block XPOW. Using an external supply is recommended if

- the application requires fast start after connecting the drive to the main supply
- fieldbus communication is required when the input power supply is disconnected.

DI6 (XDI:6) as a thermistor input

1...3 PTC sensors can be connected to this input for motor temperature measurement.

One sensor

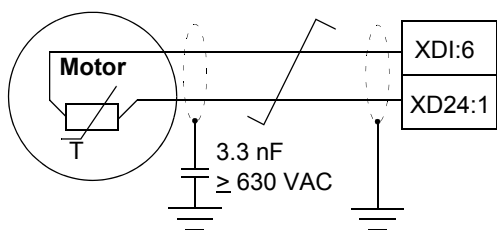

Three sensors

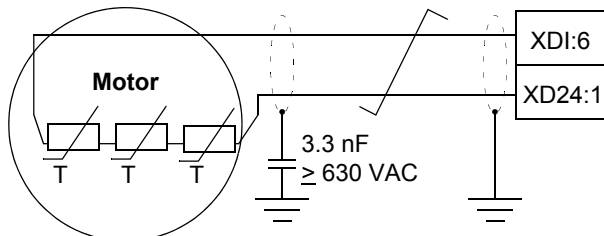

Notes:

- Do not connect both ends of the cable shields directly to ground. If a capacitor cannot be used at one end, leave that end of the shield unconnected.
- The connection of temperature sensors involves parameter adjustment. See the *Firmware manual* of the drive.
- PTC (as well as KTY84) sensors can alternatively be connected to a FEN-xx encoder interface. See the *User's manual* of the interface for wiring information.
- Pt100 sensors are not to be connected to the thermistor input. Instead, an analog input and an analog current output (located either on the JCU or on an I/O extension module) are used as shown below. The analog input must be set to voltage.

One Pt100 sensor

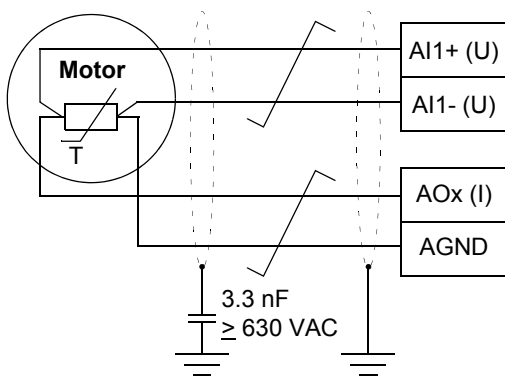

Three Pt100 sensors

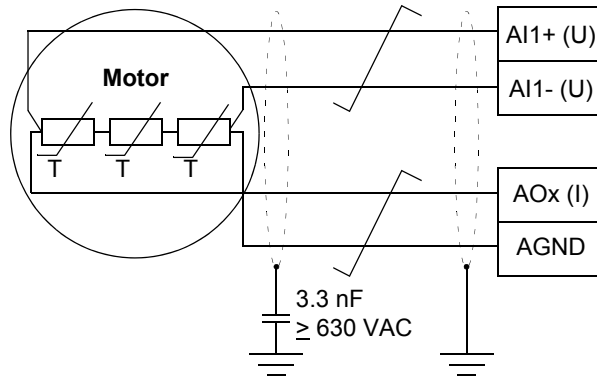



WARNING! As the inputs pictured above are not insulated according to IEC 60664, the connection of the motor temperature sensor requires double or reinforced insulation between motor live parts and the sensor. If the assembly does not fulfil the requirement,

- all I/O terminals must be protected against contact and must not be connected to other equipment

or

- the temperature sensor must be isolated from the I/O terminals.

Drive-to-drive link (XD2D)

The drive-to-drive link is a daisy-chained RS-485 transmission line that allows basic master/follower communication with one master drive and multiple followers.

Termination activation jumper T (see section [Jumpers](#) above) next to this terminal block must be set to the ON position on the drives at the ends of the drive-to-drive link. On intermediate drives, the jumper must be set to the OFF position.

Shielded twisted-pair cable (~100 ohm, e.g. PROFIBUS-compatible cable) must be used for the wiring. For best immunity, high quality cable is recommended. The cable should be kept as short as possible; the maximum length of the link is 100 metres (328 ft). Unnecessary loops and running the cable near power cables (such as motor cables) must be avoided. The cable shields are to be grounded to the control cable clamp plate on the drive as shown on page [73](#).

The following diagram shows the wiring of the drive-to-drive link.

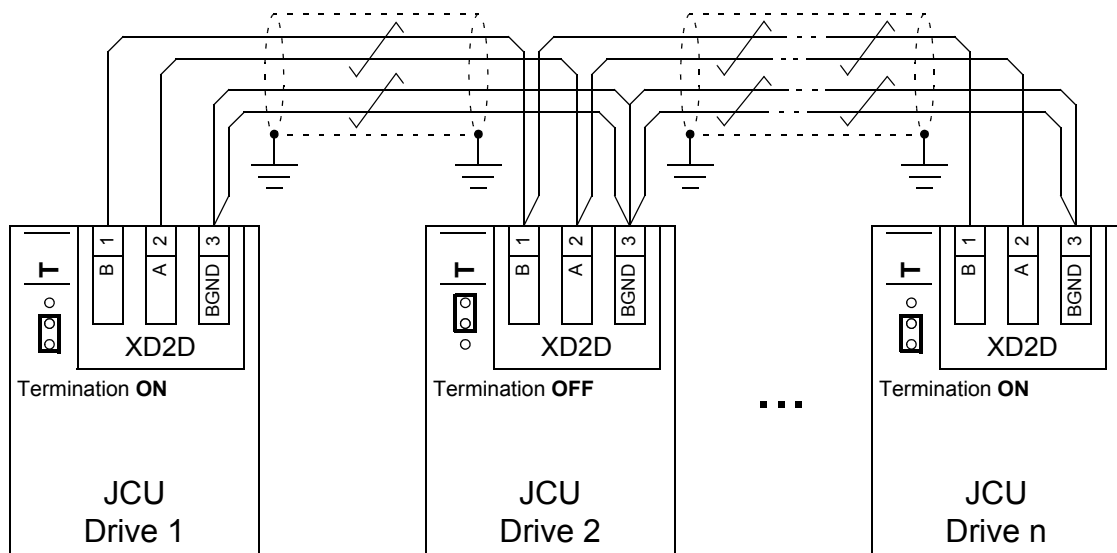

Note: The drive-to-drive link can be used only if the embedded fieldbus interface is disabled. For more information on the embedded fieldbus interface, see the *Firmware manual*.

Safe torque off (XSTO)

For the drive to start, both connections (OUT1 to IN1, and OUT2 to IN2) must be closed. This is implemented by means of a safety switch and related wiring. See page 43.

By default, the terminal block has jumpers to close the circuit. Remove the jumpers before connecting an external Safe Torque Off circuitry to the drive. See page 43.

More information is available in *Safe torque off function for ACS850 and ACQ810 drives application guide* (3AFE68929814 [English]). For related parameter settings, see the appropriate *Firmware manual*.

Grounding and routing the control cables

The shields of all control cables connected to the JCU control unit must be grounded at the control cable clamp plate. Use four M4 screws to fasten the plate as shown below (two of the screws are also used to hold the cover mounting bracket). The plate can be fitted either at the top or bottom of the drive.

Before connecting the wires, run the cables through the cover mounting bracket. The cables going to the terminal blocks on the control unit are to be run along the right-hand side of the drive module. See the drawings below.

The shields should be continuous as close to the terminals of the JCU as possible. Only remove the outer jacket of the cable at the cable clamp so that the clamp presses on the bare shield. At the terminal block, use shrink tubing or insulating tape to contain any stray strands. The shield (especially in case of multiple shields) can also be terminated with a lug and fastened with a screw at the clamp plate. Leave the other end of the shield unconnected or ground it indirectly via a few nanofarads high-frequency capacitor (e.g. 3.3 nF / 630 V). The shield can also be grounded directly at both ends if they are *in the same ground line* with no significant voltage drop between the end points.

Keep any signal wire pairs twisted as close to the terminals as possible. Twisting the wire with its return wire reduces disturbances caused by inductive coupling.

Before re-installing the cover assembly, remove the appropriate punch-outs on the right side of the cover base to create entries for the control cables going to the terminal blocks.

Re-install the cover assembly according to the instructions on page 49.

Mounting the clamp plate

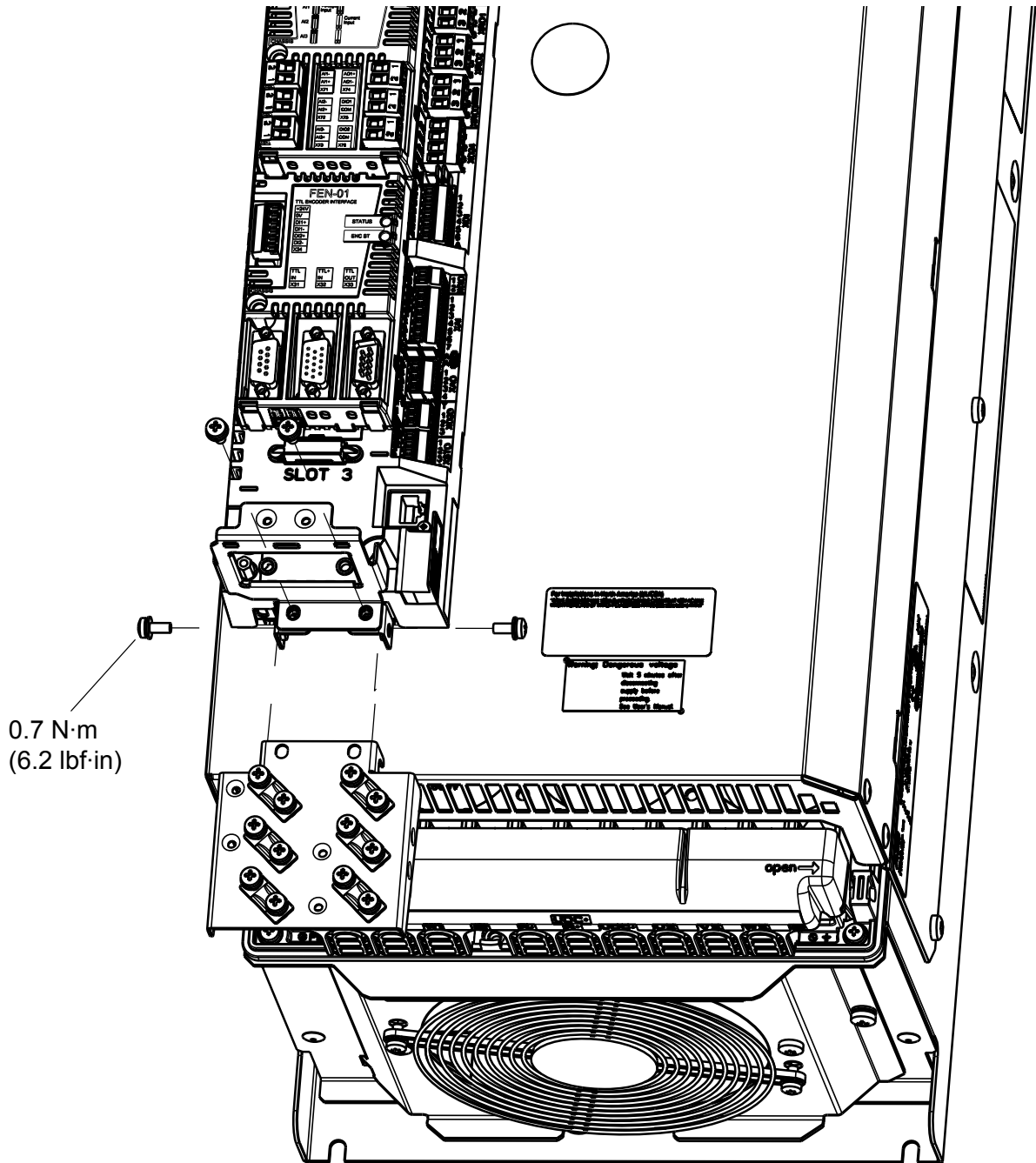

Routing the control cables

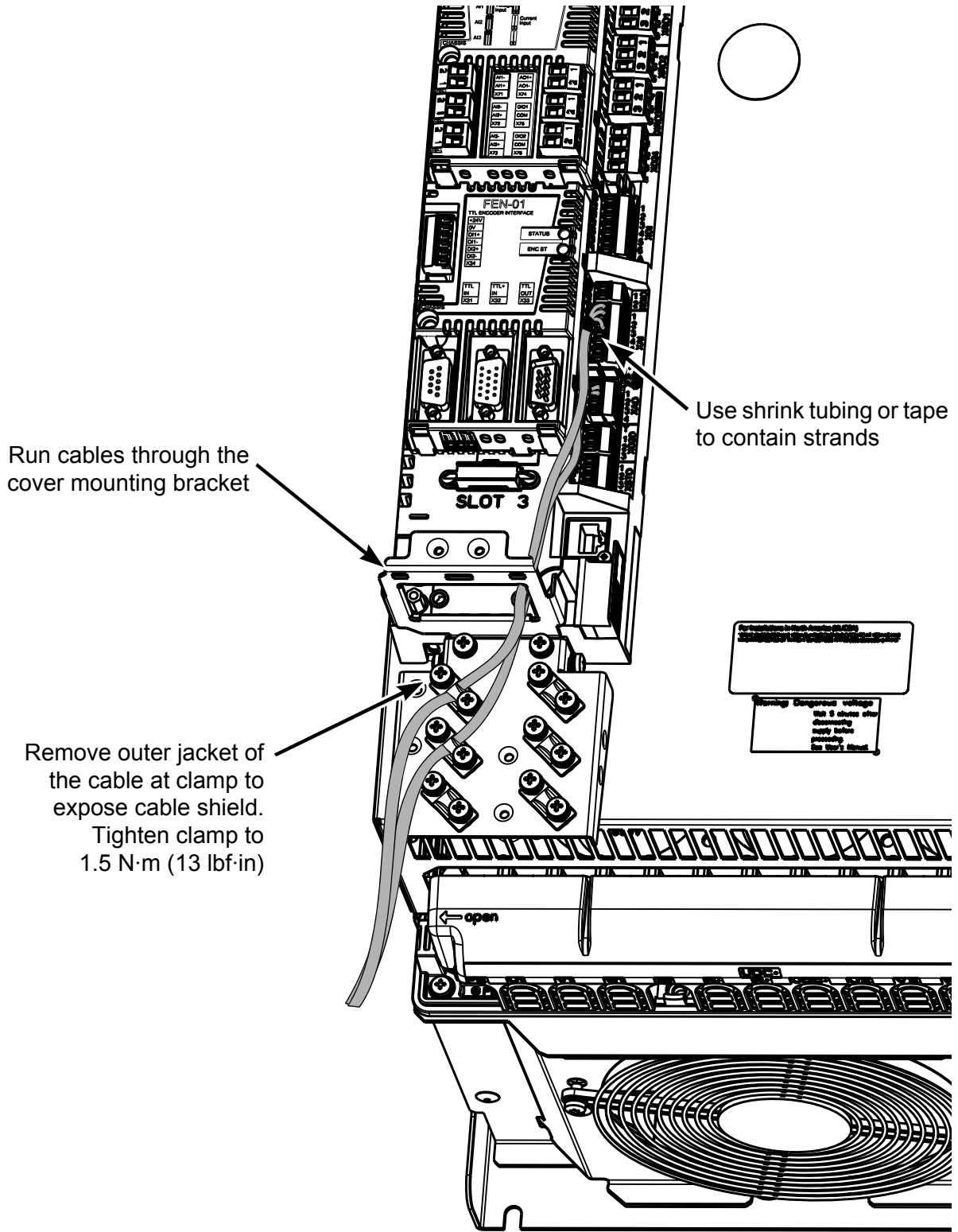

Installation checklist

What this chapter contains

This chapter contains a list for checking the mechanical and electrical installation of the drive.

Checklist

Check the mechanical and electrical installation of the drive before start-up. Go through the checklist below together with another person. Read the [Safety instructions](#) on the first pages of this manual before you work on the unit.

<input checked="" type="checkbox"/>	Check that...
MECHANICAL INSTALLATION	
<input type="checkbox"/>	The ambient operating conditions are allowable. (See Mechanical installation, Technical data: Ratings, Ambient conditions.)
<input type="checkbox"/>	The unit is fastened properly to the cabinet. (See Planning the cabinet assembly and Mechanical installation.)
<input type="checkbox"/>	The cooling air will flow freely.
<input type="checkbox"/>	The motor and the driven equipment are ready for start. (See Planning the electrical installation, Technical data: Motor connection.)
ELECTRICAL INSTALLATION (See Planning the electrical installation, Electrical installation.)	
<input type="checkbox"/>	The internal C2 EMC filter (option + E202) is disconnected if the drive is connected to an IT (ungrounded) or corner-grounded supply network.
<input type="checkbox"/>	The capacitors are reformed if stored over one year (ask local ABB representative for more information).
<input type="checkbox"/>	The drive is grounded properly. 1) There is a proper PE connector, 2) PE connector is tightened properly, and 3) there is a proper galvanic connection between the drive frame and the cabinet (fastening points are unpainted).
<input type="checkbox"/>	The supply (input power) voltage matches the drive nominal input voltage.
<input type="checkbox"/>	The supply (input power) is connected to U1/V1/W1 (UDC+/UDC- in case of a DC supply) and the terminals are tightened to specified torque.
<input type="checkbox"/>	Appropriate supply (input power) fuses and disconnectors are installed.
<input type="checkbox"/>	The motor is connected to U2/V2/W2, and the terminals are tightened to specified torque.
<input type="checkbox"/>	The braking resistor (if present) is connected to R+/R-, and the terminals are tightened to specified torque.

<input checked="" type="checkbox"/> Check that...
<input type="checkbox"/> The motor cable (and braking resistor cable, if present) is routed away from other cables.
<input type="checkbox"/> There are no power factor compensation capacitors in the motor cable.
<input type="checkbox"/> The external control connections to the JCU control unit are OK.
<input type="checkbox"/> There are no tools, foreign objects or dust from drilling inside the drive.
<input type="checkbox"/> The supply (input power) voltage cannot be applied to the output of the drive through a bypass connection.
<input type="checkbox"/> Motor connection box and other covers are in place.

Maintenance

What this chapter contains

This chapter contains preventive maintenance instructions.

Safety



WARNING! Read the [Safety instructions](#) on the first pages of this manual before performing any maintenance on the equipment. Ignoring the safety instructions can cause injury or death.

Maintenance intervals

The table below lists the routine maintenance intervals recommended by ABB. Consult a local ABB Service representative for more details. In the Internet, go to www.abb.com/drivesservices, select *Drive Services*, and *Maintenance and Field Services*.

Interval	Maintenance	Instruction
Every year of storage	DC capacitor reforming	See Capacitors .
Every 6 to 12 months depending on the dustiness of the environment	Heatsink temperature check and cleaning	See Heatsink .
Every year	Inspection of tightness of power connections	See pages 64-66 .
	Visual inspection of cooling fan	See Cooling fan .
Every 3 years if the ambient temperature is higher than 40 °C (104 °F). Otherwise, every 6 years .	Cooling fan replacement	See Cooling fan .
Every 3 years	Change of additional cooling fan (only frame size E0)	See Additional cooling fan replacement (frame E0) .
Every 6 years if the ambient temperature is higher than 40 °C (104 °F) or if the drive is subjected to cyclic heavy load or continuous nominal load. Otherwise, every 9 years	DC capacitor replacement	See Capacitors .

Every 10 years	Control panel battery replacement	The battery is housed on the rear of the control panel. Replace with a new CR 2032 battery.
-----------------------	-----------------------------------	---

Heatsink

The heatsink fins pick up dust from the cooling air. The drive runs into overtemperature warnings and faults if the heatsink is not clean. In a normal environment, the heatsink should be checked annually, in a dusty environment more often.

Clean the heatsink as follows (when necessary):

1. Remove the cooling fan (see section [Cooling fan](#)).
2. Blow clean compressed air (not humid) from bottom to top and simultaneously use a vacuum cleaner at the air outlet to trap the dust.
Note: If there is a risk of the dust entering adjoining equipment, perform the cleaning in another room.
3. Refit the cooling fan.

Cooling fan

The actual lifespan of the cooling fan depends on the drive usage and ambient temperature. Fan failure can be predicted by the increasing noise from fan bearings and the gradual rise in the heatsink temperature in spite of heatsink cleaning. If the drive is operated in a critical part of a process, fan replacement is recommended once these symptoms start appearing. Replacement fans are available from ABB. Do not use other than ABB-specified spare parts.

Fan replacement (frame E0)

1. Undo the fixing screw of the cooling fan holder.
2. Remove the cooling fan holder and disconnect the cable.
3. Undo the fastening screws of the fan.

Install the new fan in reverse order.

Frame size E0, bottom view

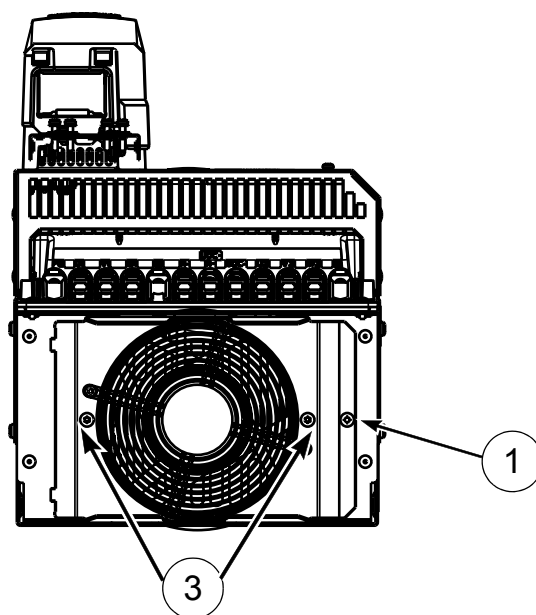

Fan replacement (frame E)

1. Undo the fixing screw of the cooling fan holder.
 2. Slide out the cable connector and disconnect it.
 3. Remove the cooling fan holder and replace the fan onto the holder's pins.
- Install the cooling fan holder in reverse order.

Frame size E, bottom view

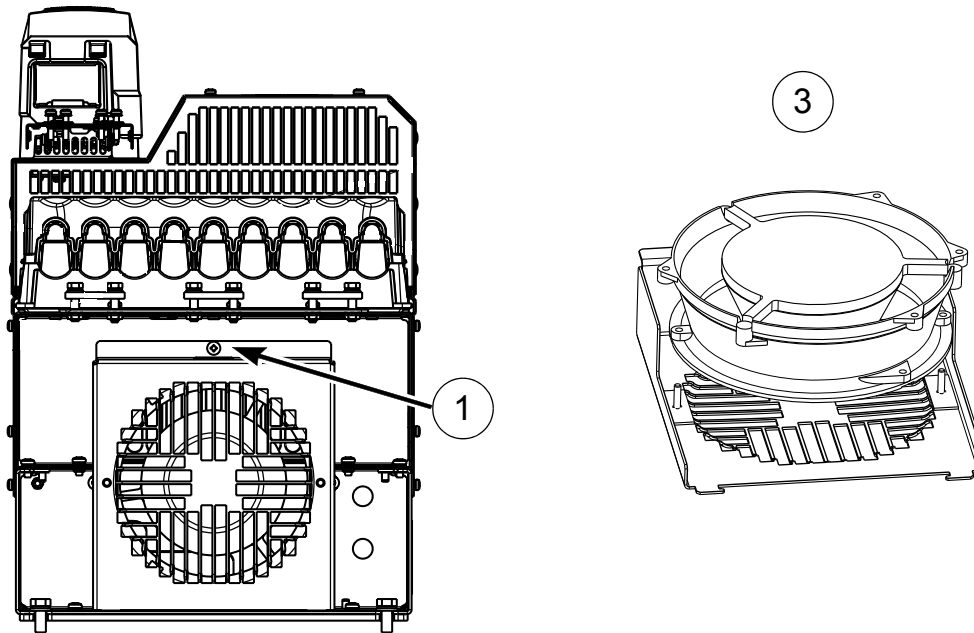

Additional cooling fan replacement (frame E0)

The fan is located on top of the module.

1. Undo the fixing screw of the cooling fan holder (1 pc PZ2 screw).
2. Pull the fan holder out.
3. Disconnect the fan cable.
4. Undo the fastening screws of the fan (4 pcs PZ2 screws, circled in the picture below) and remove the fan.
5. Install the new fan and tighten the fastening screws to 0.5 N·m.
6. Reconnect the fan cable, assemble the fan holder back and tighten the fixing screw to 1.2 N·m.

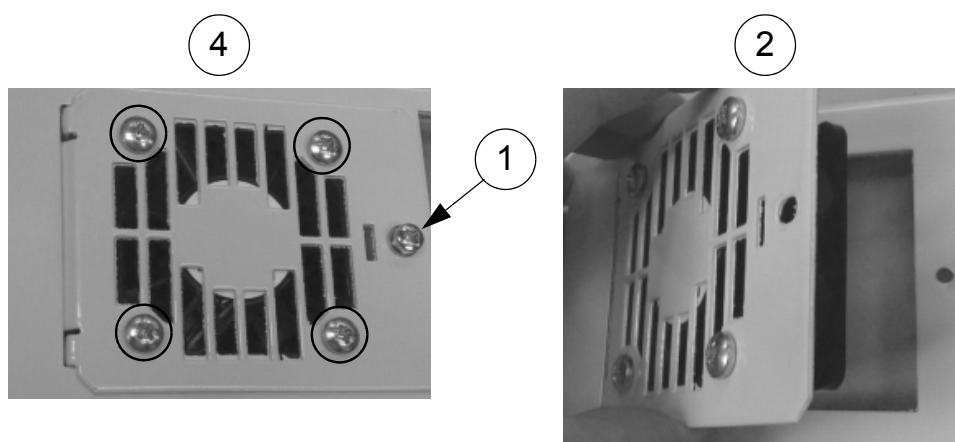

Capacitors

Reforming

The capacitors must be reformed if the drive has been stored for a year or more. See page 33 for information on finding out the manufacturing date. For the reforming instructions, see *Converter modules with electrolytic DC capacitors in the DC link, capacitor reforming instructions* (3BFE64059629 [English]).

Changing

The drive intermediate circuit employs several electrolytic capacitors. Their lifespan depends on drive loading and ambient temperature. Capacitor life can be prolonged by lowering the ambient temperature.

It is not possible to predict a capacitor failure. Capacitor failure is usually followed by a mains fuse failure or a fault trip. Contact ABB if capacitor failure is suspected. Replacements are available from ABB. Do not use other than ABB specified spare parts.

Other maintenance actions

Transferring the memory unit to a new drive module

When a drive module is replaced, the parameter settings can be retained by transferring the memory unit from the defective drive module to the new module.



WARNING! Do not remove or insert a memory unit when the drive module is powered.

After power-up, the drive will scan the memory unit. If a different application program or different parameter settings are detected, they are copied to the drive.

Technical data

What this chapter contains

This chapter contains the technical specifications of the drive, for example, the ratings, sizes and technical requirements, and provisions for fulfilling the requirements for CE and other markings.

Ratings

400 V AC supply

The nominal ratings for the drive with 400 V AC supply are given below.

Drive type ACS850-04-...	Frame size	Input ratings	Output ratings						
			Nominal			No-overload use	Light-overload use		Heavy-duty use
		I_{1N} A	I_{2N} A	I_{Max} A	P_N kW	I_{Ld} A	P_{Ld} kW	I_{Hd} A	P_{Hd} kW
103A-5	E0	100	103	138	55	100	55	83	45
144A-5	E0	142	144	170	75	141	75	100	55
166A-5	E	163	166	202	90	155	75	115	55
202A-5	E	198	202	282	110	184	90	141	75
225A-5	E	221	225	326	110	220	110	163	90
260A-5	E	254	260	326	132	254	132	215	110
290A-5	E	283	290	348	160	286	160	232	132

00581898

480 V AC supply

The nominal ratings for the drive with 480 V AC supply are given below.

Drive type ACS850-04-...	Frame size	Input ratings	Output ratings						
			Nominal			No-overload use	Light-overload use		Heavy-duty use
		I_{1N} A	I_{2N} A	I_{Max} A	P_N hp	I_{Ld} A	P_{Ld} hp	I_{Hd} A	P_{Hd} hp
103A-5	E0	100	103	138	75	100	75	83	60
144A-5	E0	142	144	170	100	141	100	100	75
166A-5	E	163	166	202	125	155	125	115	75
202A-5	E	198	202	282	150	184	150	141	100
225A-5	E	221	225	326	150	220	150	163	125
260A-5	E	254	260	326	200	254	200	215	150
290A-5	E	283	290	348	200	286	200	232	150

00581898

500 V AC supply

The nominal ratings for the drive with 500 V AC supply are given below.

Drive type ACS850-04-...	Frame size	Input ratings	Output ratings						
			Nominal			No-overload use	Light-overload use		Heavy-duty use
		I_{1N} A	I_{2N} A	I_{Max} A	P_N kW	I_{Ld} A	P_{Ld} kW	I_{Hd} A	P_{Hd} kW
103A-5	E0	100	103	138	55	100	55	83	55
144A-5	E0	142	144	170	90	141	90	100	55
166A-5	E	163	166	202	110	155	90	115	75
202A-5	E	198	202	282	132	184	110	141	90
225A-5	E	221	225	326	132	220	132	163	110
260A-5	E	254	260	326	160	254	160	215	132
290A-5	E	283	290	348	200	286	200	232	160

00581898

Derating

The continuous output currents stated above must be derated if any of the following conditions apply:

- the ambient temperature exceeds +40 °C (+104 °F)
- the drive is installed higher than 1000 m (3300 ft) above sea level.
- the parameter-adjustable Motor noise level is set as Low noise.

Note: The final derating factor is a multiplication of all applicable derating factors.

Ambient temperature derating

In the temperature range +40...55 °C (+104...131 °F), the rated output current is derated by 1% for every added 1 °C (1.8 °F) as follows:

Derating factor

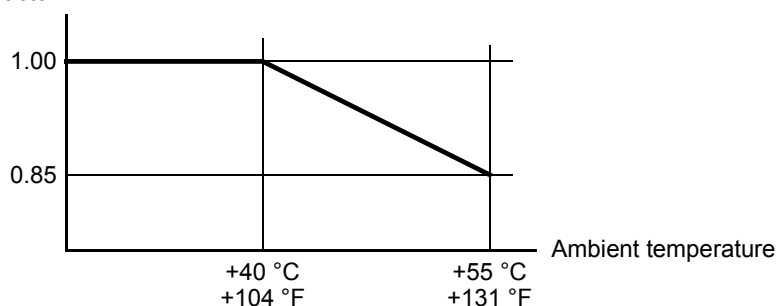

Altitude derating

At altitudes from 1000 to 4000 m (3300 to 13123 ft) above sea level, the derating is 1% for every 100 m (328 ft). For a more accurate derating, use the DriveSize PC tool.

Note: If the installation site is higher than 2000 m (6600 ft) above sea level, connection of the drive to an ungrounded (IT) or corner-grounded delta network is not allowed.

Dimensions, weights, noise

See also chapter [Dimension drawings](#).

Frame size	Height mm (in.)	Width mm (in.)	Depth mm (in.)	Weight kg (lbs)	Noise dB
E0	602 (23.7")	276 (10.9")	376 (14.8")	34 (75 lbs)	65
E	700 (27.6")	312 (12.3")	465 (18.3")	67 (148 lbs)	65

00581898

Cooling characteristics

Drive type ACS850-04-...	Heat dissipation		Air flow	
	W	BTU/h	m ³ /h	ft ³ /min
103A-5	1190	4050	168	99
144A-5	1440	4910	405	238
166A-5	1940	4910	405	238
202A-5	2310	6610	405	238
225A-5	2810	7890	405	238
260A-5	3260	11140	405	238
290A-5	4200	14350	405	238

Supply cable fuses

Fuses for short circuit protection of the supply cable are listed below. The fuses also protect the adjoining equipment of the drive in case of a short circuit. The operating time depends on the supply network impedance and the cross-sectional area and length of the supply cable. See also chapter [Planning the electrical installation](#).

Note: Fuses with a higher current rating must not be used.

Drive type ACS850-04-...	Input current (A)	IEC fuse				UL fuse			Cross-sectional area of cable	
		gG		aR		UL recognised Class T				
		Rated current (A)	Voltage (V)	Rated current (A)	Voltage (V)	Rated current (A)	Voltage (V)	Type	mm ²	AWG/MCM
103A-5	100	125	500	160	690	125	600	JJS-125	6...70	10...2/0
144A-5	142	160	500	315	690	150	600	JJS-150	6...70	10...2/0
166A-5	163	200	500	315	690	200	600	JJS-200	95...240	500MCM
202A-5	198	250	500	400	690	250	600	JJS-250	95...240	500MCM
225A-5	221	250	500	500	690	300	600	JJS-300	95...240	500MCM
260A-5	254	315	500	500	690	350	600	JJS-350	95...240	500MCM
290A-5	283	315	500	550	690	400	600	JJS-400	95...240	500MCM

00581898

Note: AWG cable sizing is based on NEC Table 310-16 for copper wires, 75 °C (167 °F) wire insulation at 40 °C (104 °F) ambient temperature. Not more than three current-carrying conductors in raceway or cable or earth (directly buried). For other conditions, dimension the cables according to local safety regulations, appropriate input voltage and the load current of the drive.

AC input (supply) connection

Voltage (U_1)	380 ... 500 V AC +10%/-15%, 3-phase
Frequency	50 ... 60 Hz \pm 5%
Network type	Grounded (TN, TT) or ungrounded (IT). Note: Connection to an ungrounded (IT) or corner-grounded delta network is not allowed at altitudes of 2000 m (6600 ft) or higher.
Imbalance	Max. \pm 3% of nominal phase to phase input voltage
Fundamental power factor (cos ϕ_1)	0.98 (at nominal load)
Terminals	Frame size E0: With cable sizes from 6 to 70 mm ² (AWG10 to AWG2/0): Posts for crimp lugs (lugs not included). Frame size E: With cable sizes from 95 to 240 mm ² (400MCM): Screw lugs (included). Grounding clamps.

DC connection

Voltage	436 ... 743 V DC
Terminals	Frame E0: 6 to 70 mm ² Frame E: 95 to 240 mm ²

Motor connection

Motor types	Asynchronous induction motors, permanent magnet synchronous motors, ABB synchronous reluctance motors (SynRM motors)
Frequency	0 ... 500 Hz
Current	See section Ratings .
Switching frequency	3 kHz as default.
Maximum motor cable length	General: 300 m. Note: With cables longer than 100 m (328 ft), the EMC Directive requirements may not be fulfilled. See section CE marking .
Terminals	Frame size E0: With cable sizes from 6 to 70 mm ² (AWG10 to AWG2/0): Posts for crimp lugs (lugs not included). Frame size E: With cable sizes from 95 to 240 mm ² (400MCM): Screw lugs (included). Grounding clamps.

JCU control unit

Power supply	24 V (\pm 10%) DC, 1.6 A Supplied from the power unit of the drive, or from an external power supply through connector XPOW (pitch 5 mm, wire size 2.5 mm ²).
Relay outputs RO1...RO3 (XRO1 ... XRO3)	Connector pitch 5 mm, wire size 2.5 mm ² 250 V AC / 30 V DC, 2 A Protected by varistors Note: The relay outputs of the drive do not fulfil the Protective Extra Low Voltage (PELV) requirements at installation sites above 4000 meters (13123 feet) if used with a voltage greater than 48 V. At installation sites between 2000 meters (6562 feet) and 4000 meters (13123 feet), PELV requirements are not fulfilled if one or two relay outputs are used with a voltage greater than 48 V and the remaining relay output(s) are used with a voltage lower than 48 V.
+24 V output (XD24)	Connector pitch 5 mm, wire size 2.5 mm ²

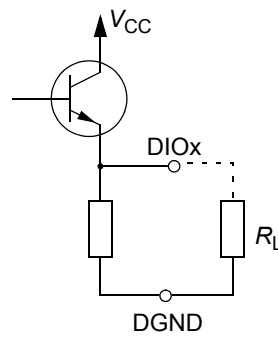
Digital inputs DI1...DI6 (XDI:1 ... XDI:6)	Connector pitch 3.5 mm, wire size 1.5 mm ² 24 V logic levels: "0" < 5 V, "1" > 15 V R_{in} : 2.0 kohm Input type: NPN/PNP (DI1...DI5), NPN (DI6) Filtering: 0.25 ms min DI6 (XDI:6) can alternatively be used as an input for 1...3 PTC thermistors. "0" > 4 kohm, "1" < 1.5 kohm I_{max} : 15 mA
Start interlock input DIIL (XDI:A)	Wire size 1.5 mm ² 24 V logic levels: "0" < 5 V, "1" > 15 V R_{in} : 2.0 kohm Input type: NPN/PNP Filtering: 0.25 ms min
Digital inputs/outputs DIO1 and DIO2 (XDIO:1 and XDIO:2)	Connector pitch 3.5 mm, wire size 1.5 mm ²
Input/output mode selection by parameters.	<u>As inputs:</u> 24 V logic levels: "0" < 5 V, "1" > 15 V R_{in} : 2.0 kohm Filtering: 0.25 ms min
DIO1 can be configured as a frequency input (0...16 kHz) for 24 V level square wave signal (sinusoidal or other wave form cannot be used). DIO2 can be configured as a 24 V level square wave frequency output. See <i>Firmware manual</i> , parameter group 12.	<u>As outputs:</u> Total output current limited by auxiliary voltage outputs to 200 mA Output type: Open emitter
	
Reference voltage for analog inputs +VREF and -VREF (XAI:1 and XAI:2)	Connector pitch 3.5 mm, wire size 1.5 mm ² 10 V ±1% and -10 V ±1%, $R_{load} > 1$ kohm
Analog inputs AI1 and AI2 (XAI:4 ... XAI:7).	Connector pitch 3.5 mm, wire size 1.5 mm ² Current input: -20...20 mA, R_{in} : 100 ohm Voltage input: -10...10 V, R_{in} : 200 kohm Differential inputs, common mode ±20 V Sampling interval per channel: 0.25 ms Filtering: 0.25 ms min Resolution: 11 bit + sign bit Inaccuracy: 1% of full scale range
Analog outputs AO1 and AO2 (XAO)	Connector pitch 3.5 mm, wire size 1.5 mm ² 0...20 mA, $R_{load} < 500$ ohm Frequency range: 0...800 Hz Resolution: 11 bit + sign bit Inaccuracy: 2% of full scale range
Drive to drive link (XD2D)	Connector pitch 3.5 mm, wire size 1.5 mm ² Physical layer: RS-485 Termination by jumper
Safe torque off connection (XSTO)	Connector pitch 3.5 mm, wire size 1.5 mm ² For the drive to start, both connections (OUT1 to IN1, and OUT2 to IN2) must be closed
Control panel / PC connection	Connector: RJ-45 Cable length < 3 m

Isolation and grounding diagram

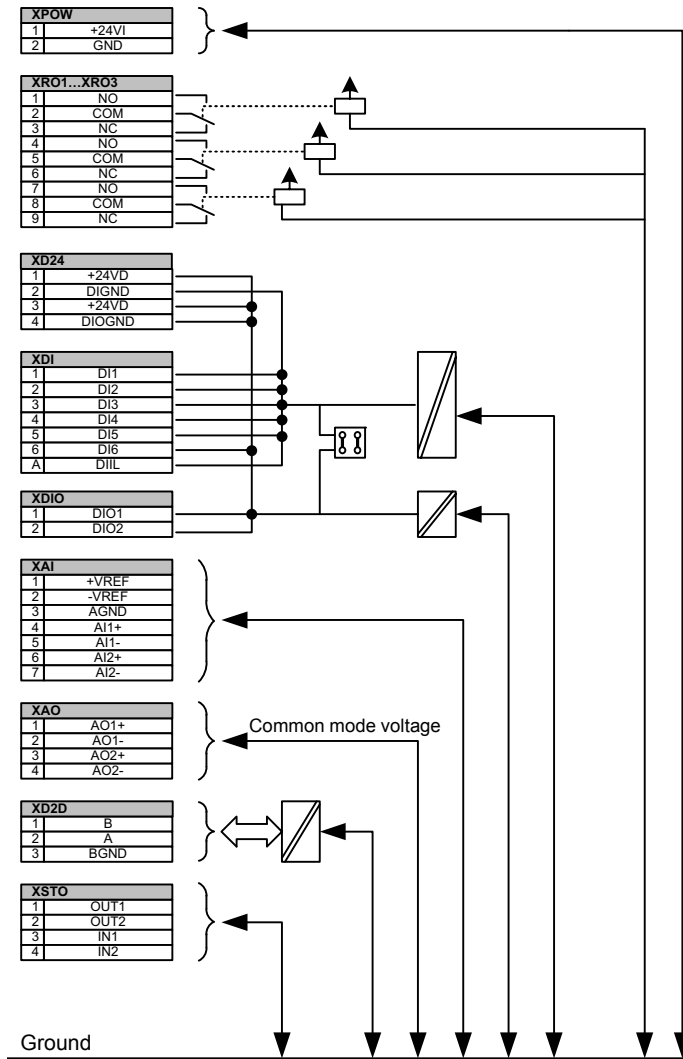

Efficiency

Approximately 98% at nominal power level

Cooling

Method Forced air cooling (internal fan, flow direction from bottom to top). On/off control to have cooling only, when drive is running.

Free space around the unit See chapter [Planning the cabinet assembly](#).

Degree of protection

IP20 (UL open type). See chapter [Planning the cabinet assembly](#).

Ambient conditions

Environmental limits for the drive are given below. The drive is to be used in a heated, indoor, controlled environment.

	Operation installed for stationary use	Storage in the protective package	Transportation in the protective package
Installation site altitude	0 to 4000 m (6600 ft) above sea level. (See also section Derating on page 86.)	-	-
Air temperature	-10 to +55 °C (14 to 131 °F). No frost allowed. See section Derating on page 86.	-40 to +70 °C (-40 to +158 °F)	-40 to +70 °C (-40 to +158 °F)
Relative humidity	5 to 95%	Max. 95%	Max. 95%
	No condensation allowed. Maximum allowed relative humidity is 60% in the presence of corrosive gases.		
Contamination levels (IEC 60721-3-3, IEC 60721-3-2, IEC 60721-3-1)	No conductive dust allowed. Not allowed: -Conductive dust -Frost or condensation Contamination levels -EN50178: Level 2 -EN 60721-3-3: Chemical gases / Class3C2, solid particles / Class3S2 Climatic class -EN 60721-3-3: 3K3	Not allowed: -Conductive dust -Frost or condensation Contamination levels -EN50178: Level 2 -Transportation acc. EN 60721-3-2: Chemical gases / Class2C2, solid particles / Class2S2 -Storage acc. EN 60721-3-1: Chemical gases / Class1C2, solid particles / Class1S2 Climatic class -EN 60721-3-2: 2K4 -EN 60721-3-1: 1K3	Not allowed: -Conductive dust -Frost or condensation Contamination levels -EN50178: Level 2 -Transportation acc. EN 60721-3-2: Chemical gases / Class2C2, solid particles / Class2S2 -Storage acc. EN 60721-3-1: Chemical gases / Class1C2, solid particles / Class1S2 Climatic class -EN 60721-3-2: 2K4 -EN 60721-3-1: 1K3
Sinusoidal vibration (IEC 60721-3-3)	5...13,2 Hz / 1 mm, 13,2...100 Hz / 7 m/s ²	-	-
Insulation strength	Overvoltage category: -Class III to EN 60 664-1	-	-
Shock (IEC 60068-2-27, ISTA 1B)	-	According to ISTA 1B. Max. 100 m/s ² (330 ft/s ²), 11 ms	According to ISTA 1B. Max. 100 m/s ² (330 ft/s ²), 11 ms
Free fall	Not allowed	25 cm (10")	25 cm (10")

Materials

Drive enclosure	<ul style="list-style-type: none"> • JCU control unit housing: PC/ABS, colour NCS 1502-Y (RAL 9002 / PMS 420 C) • Sheet metal parts: Hot-dip zinc-coated steel. Front cover painted on the outside, colour NCS 1502-Y (RAL 9002 / PMS 420 C) • Heatsink: Extruded aluminium AlSi.
Packaging	Cardboard, plywood, PE-LD wrapping, PP or steel banding.
Disposal	<p>The drive contains raw materials that should be recycled to preserve energy and natural resources. The package materials are environmentally compatible and recyclable. All metal parts can be recycled. The plastic parts can either be recycled or burned under controlled circumstances, according to local regulations. Most recyclable parts are marked with recycling marks.</p> <p>If recycling is not feasible, all parts excluding electrolytic capacitors and printed circuit boards can be landfilled. The DC capacitors contain electrolyte, which is classified as hazardous waste within the EU. They must be removed and handled according to local regulations.</p> <p>For further information on environmental aspects and more detailed recycling instructions, please contact your local ABB distributor.</p>

Applicable standards

	The drive complies with the following standards. The compliance with the European Low Voltage Directive is verified according to standards EN 50178 and EN 60204-1.
<ul style="list-style-type: none"> • EN 50178: 1997 • IEC 60204-1: 2006 	<p>Electronic equipment for use in power installations</p> <p>Safety of machinery. Electrical equipment of machines. Part 1: General requirements. <i>Provisions for compliance:</i> The final assembler of the machine is responsible for installing</p> <ul style="list-style-type: none"> - an emergency-stop device - a supply disconnecting device - the drive module into a cabinet.
<ul style="list-style-type: none"> • EN 60529: 1991 (IEC 60529) • IEC 60664-1:2007 	<p>Degrees of protection provided by enclosures (IP code)</p> <p>Insulation coordination for equipment within low-voltage systems. Part 1: Principles, requirements and tests.</p>
<ul style="list-style-type: none"> • IEC 61800-3: 2004 	Adjustable speed electrical power drive systems. Part 3: EMC requirements and specific test methods.
<ul style="list-style-type: none"> • EN 61800-5-1: 2003 	<p>Adjustable speed electrical power drive systems.</p> <p>Part 5-1: Safety requirements. Electrical, thermal and energy <i>Provisions for compliance:</i> The final assembler of the machine is responsible for installing the ACS850-04 in a cabinet that is protected to IP3X for top surfaces for vertical access.</p>
<ul style="list-style-type: none"> • prEN 61800-5-2:2007 	Adjustable speed electrical power drive systems. Part 5-2: Safety requirements. Functional
<ul style="list-style-type: none"> • UL 508C: 2002, Third Edition 	UL Standard for Safety, Power Conversion Equipment
<ul style="list-style-type: none"> • NEMA 250: 2003 	Enclosures for Electrical Equipment (1000 Volts Maximum)
<ul style="list-style-type: none"> • CSA C22.2 No. 14-05 (2005) 	Industrial Control Equipment

CE marking

A CE mark is attached to the drive to verify that the drive follows the provisions of the European Low Voltage and EMC Directives (Directive 2006/95/EC and Directive 2004/108/EC).

Compliance with the European Low Voltage Directive

The compliance with the European Low Voltage Directive has been verified according to standards EN 50178, EN 61800-5-1 and EN 60204-1.

Compliance with the European EMC Directive

The cabinet builder is responsible for the compliance of the drive system with the European EMC Directive. For information on items to consider, see:

- Subsections [Compliance with EN 61800-3:2004, category C2](#); [Compliance with EN 61800-3: 2004, category C3](#); and [Compliance with EN 61800-3: 2004, category C4](#) below
- Chapter [Planning the electrical installation](#) in this manual
- *Technical Guide No. 3 – EMC Compliant Installation and Configuration for a Power Drive System* (3AFE61348280 [English]).

Definitions

EMC stands for **E**lectromagnetic **C**ompatibility. It is the ability of electrical/electronic equipment to operate without problems within an electromagnetic environment. Likewise, the equipment must not disturb or interfere with any other product or system within its locality.

First environment includes domestic premises. It also includes establishments directly connected without intermediate transformers to a low-voltage network which supplies buildings used for domestic purposes.

Second environment includes all establishments other than those directly connected to a low-voltage network which supplies buildings used for domestic purposes.

Drive of category C2. Power drive system with rated voltage less than 1000 V which is neither a plug-in device nor a movable device and, when used in the first environment, is intended to be installed and commissioned only by a professional.

Drive of category C3. Power drive system with rated voltage less than 1000 V, intended for use in the second environment and not intended for use in the first environment.

Drive of category C4. Power drive system with rated voltage equal to or above 1000 V, or rated current equal to or above 400 A, or intended for use in complex systems in the second environment.

Compliance with EN 61800-3:2004, category C2

The drive meets the requirements of the EMC Directive with the following provisions:

1. The drive is equipped with filtering option +E202.
2. The motor and control cables are selected as specified in chapter [Planning the electrical installation](#).
3. The drive is installed according to the instructions given in this manual.
4. Motor cable length does not exceed 100 metres (328 ft).

Note: It is not allowed to use the optional EMC filter on IT (ungrounded) systems. The supply network becomes connected to ground potential through the EMC filter capacitors which may cause danger or damage the drive.

Note: It is not allowed to use the optional EMC filter on a corner-grounded TN system as this would damage the drive.



WARNING! The drive may cause radio interference if used in a residential or domestic environment. The user is required to take measures to prevent interference, in addition to the requirements for CE compliance listed above, if necessary.

Compliance with EN 61800-3: 2004, category C3

The drive meets the requirements of the EMC Directive with the following provisions:

1. The drive is equipped with filtering option +E210.
2. The motor and control cables are selected as specified in chapter [Planning the electrical installation](#).
3. The drive is installed according to the instructions given in this manual.
4. Motor cable length does not exceed 100 metres (328 ft).

Compliance with EN 61800-3: 2004, category C4

The drive meets the requirements of the EMC Directive with the following provisions:

1. It is ensured that no excessive emission is propagated to neighbouring low-voltage networks. In some cases, the natural suppression in transformers and cables is sufficient. If in doubt, a supply transformer with static screening between the primary and secondary windings can be used.

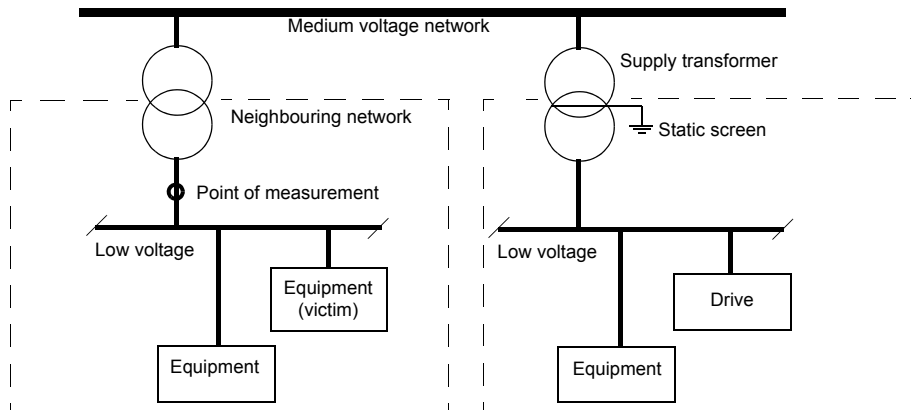

2. An EMC plan for preventing disturbances is drawn up for the installation. A template is available from the local ABB representative.
3. The motor and control cables are selected as specified in chapter [Planning the electrical installation](#).
4. The drive is installed according to the instructions given in this manual.

Compliance with the Machinery Directive

The drive is a machinery component that can be integrated into a wide range of machinery categories as specified in European Commission's Guide to application of the Machinery Directive 2006/42/EC 2nd Edition – June 2010.

C-Tick marking

Pending.

UL marking

See the type designation label for the valid markings of your drive.

UL checklist

Input power connection – See section [AC input \(supply\) connection](#) on page 88.

Disconnecting device (Disconnecting means) – See section [Supply disconnecting device](#) on page 41.

Ambient conditions – The drive is to be used in a heated indoor controlled environment. See section [Ambient conditions](#) on page 91 for specific limits.

Input cable fuses – For installation in the United States, branch circuit protection must be provided in accordance with the National Electrical Code (NEC) and any applicable local codes. To fulfil this requirement, use the UL classified fuses given in section [Supply cable fuses](#) on page 87.

For installation in Canada, branch circuit protection must be provided in accordance with the Canadian Electrical Code and any applicable provincial codes. To fulfil this requirement, use the UL classified fuses given in section [Supply cable fuses](#) on page 87.

Power cable selection – See section [Selecting the power cables](#) on page 44.

Power cable connections – For the connection diagram and tightening torques, see section [Power cable connection](#) on page 63.

Control connections – For the connection diagram and tightening torques, see section [Connecting the control cables](#) on page 69.

Overload protection – The drive provides overload protection in accordance with the National Electrical Code (US).

Braking – The drive has an internal braking chopper. When applied with appropriately sized braking resistors, the braking chopper will allow the drive to dissipate regenerative energy (normally associated with quickly decelerating a motor). Braking resistor selection is discussed in chapter [Resistor braking](#) on page 101.

UL standards – See section [Applicable standards](#) on page 92.

Dimension drawings

What this chapter contains

Dimension drawings of the drive modules (frame sizes E0 and E) are shown below.

Drive module, frame size E0

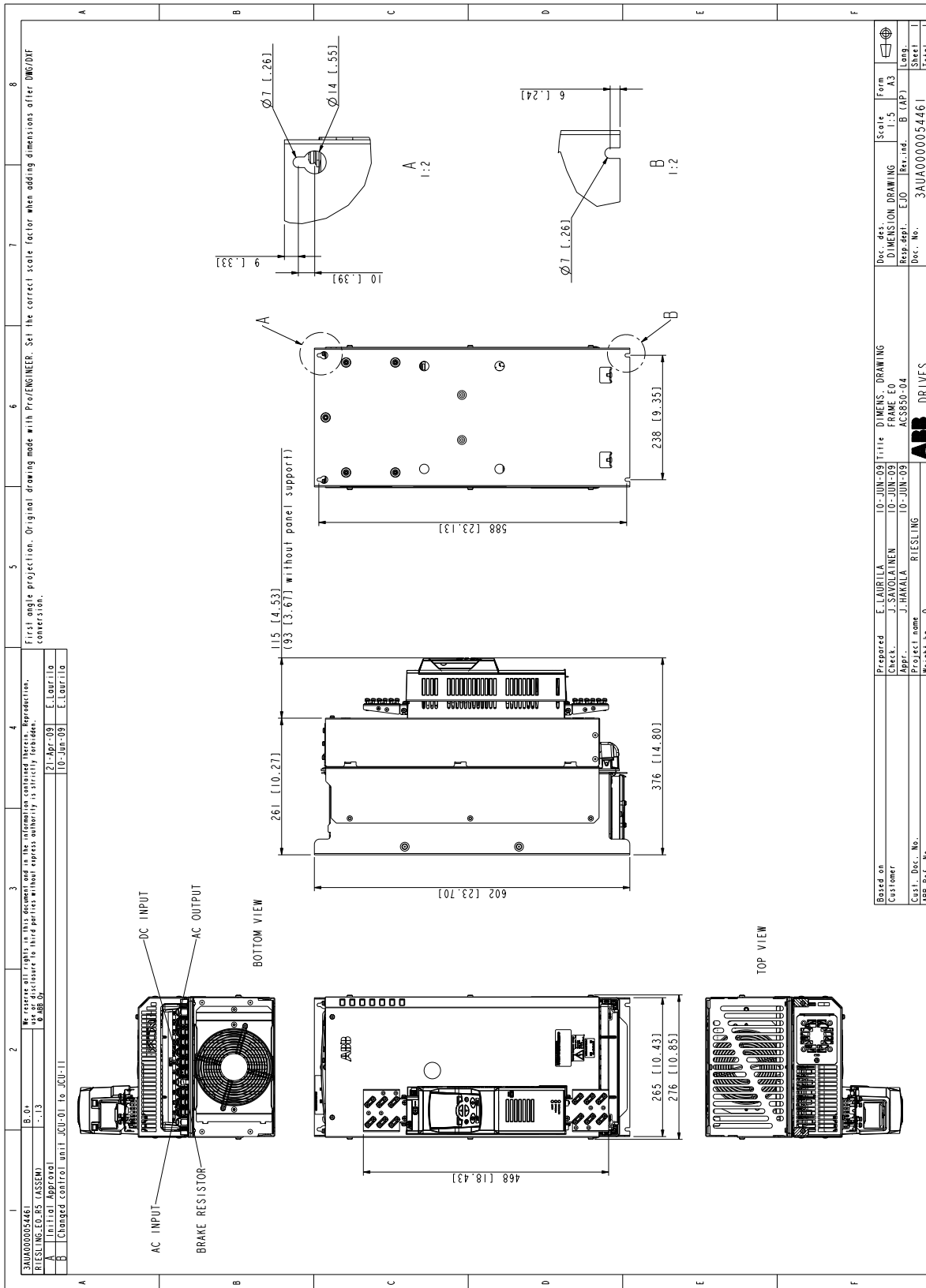

Resistor braking

What this chapter contains

This chapter describes how to select, protect and wire braking choppers and resistors. The chapter also contains the technical data.

Braking choppers and resistors with the drive

Braking choppers

Braking chopper is available as an optional equipment to handle the energy generated by a decelerating motor.

When the braking chopper is enabled and a resistor connected, the chopper will start conducting when the DC link voltage of the drive reaches 780 V. The maximum braking power is achieved at 840 V.

Braking resistor selection

To select a braking resistor:

1. Calculate the maximum power generated by the motor during braking.
2. Calculate the continuous power based on the braking duty cycle.
3. Calculate the braking energy during the duty cycle.

Pre-selected resistors are available from ABB as shown in the table below. If the listed resistor is not sufficient for the application, a custom resistor can be selected within the limits imposed by the internal braking chopper of the drive. The following rules apply:

- The resistance of the custom resistor must be at least R_{\min} . The braking power capacity with different resistance values can be calculated from the following formula

$$P_{\max} < \frac{U_{\text{DC}}^2}{R}$$

where UDC equals 840 V.



WARNING! Never use a braking resistor with a resistance below the value specified for the particular drive type. The drive and the chopper are not able to handle the overcurrent caused by the low resistance.

- The maximum braking power must not exceed P_{brmax} at any point
- The average braking power must not exceed P_{brcont}

- The braking energy must not exceed the energy dissipation capacity of the selected resistor
- The resistor must be protected from thermal overload; see section [Contactor protection of drive](#) below.

Chopper data / Resistor selection table

The ratings apply at an ambient temperature of 40 °C (104 °F).

Drive type ACS850-04-...	Braking chopper		Example braking resistor			
	P_{brcont} (kW)	R_{min} (ohm)	Type	R (ohm)	P_n (W)	E_{pulse} (kJ)
103A-5	67,5	8	SAFUR90F575	8	4500	1800
144A-5	83	6	SAFUR80F500	6	6000	2400
166A-5	112,5	4	SAFUR125F500	4	9000	3600
202A-5	135					
225A-5	135					
260A-5	160					
290A-5	200	2,7	SAFUR200F500	2,7	13500	5400

00581898

P_{brcont} The internal chopper will withstand this continuous braking power. The braking is considered continuous if the braking time exceeds 30 seconds.

R_{min} The minimum allowed resistance of the braking resistor.

R Resistance of the listed resistor.

P_n Continuous power (heat) dissipation of the listed resistor when cooled naturally in a vertical position.

E_{pulse} Energy pulse the listed resistor will withstand.

Resistor installation and wiring

All resistors must be installed outside the drive module in a place where they are cooled sufficiently, do not block the airflow to other equipment, or dissipate hot air into the air inlets of other equipment.



WARNING! The materials near the braking resistor must be non-flammable. The surface temperature of the resistor may rise above 200 °C (400 °F), and the temperature of the air flowing from the resistor is hundreds of degrees Celsius. Protect the resistor against contact.

The maximum length of the resistor cable(s) is 10 m (32,8 ft). For the connections, see section [Power cable connection](#) on page 63.

Contactor protection of drive

The drive must be equipped with a main contactor for safety reasons. Wire the contactor so that it opens in case the resistor overheats. This is essential for safety since the drive will not otherwise be able to interrupt the main supply if the chopper remains conductive in a fault situation.

Below is a simple example wiring diagram.

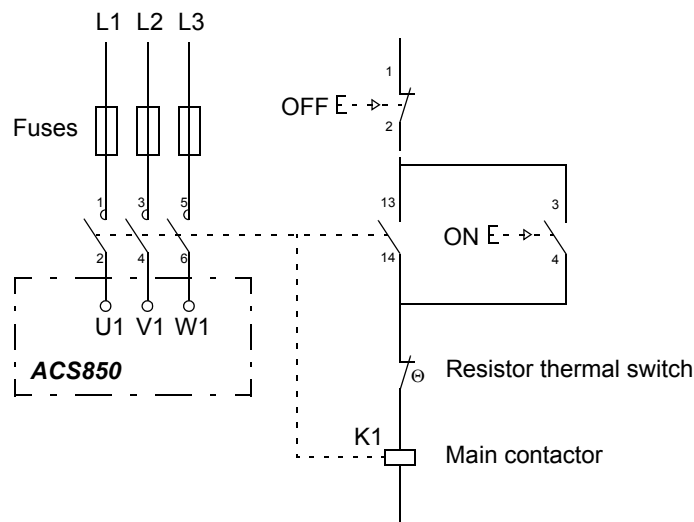

Braking circuit commissioning

For more information, see the appropriate *Firmware manual*.

- Enable the braking chopper function. Please note that a braking resistor must be connected when the chopper is enabled
- Switch off the overvoltage control of the drive
- Adjust any other relevant parameters in group 48.



WARNING! If the drive is equipped with a braking chopper but the chopper is not enabled by parameter setting, the braking resistor must be disconnected because the protection against resistor overheating is then not in use.

***du/dt* and common mode filtering**

What this chapter contains

This chapter describes how to select *du/dt* and common mode filtering for the ACS850-04. The chapter also contains the relevant technical data.

When is *du/dt* or common mode filtering required?

The output of the drive comprises – regardless of output frequency – pulses of approximately 1.35 times the equivalent supply voltage with a very short rise time. This is the case with all drives employing modern IGBT inverter technology.

The voltage of the pulses can be almost double at the motor terminals, depending on the attenuation and reflection properties of the motor cable and the terminals. This in turn can cause additional stress on the motor and motor cable insulation.

Modern variable speed drives with their fast-rising voltage pulses and high switching frequencies can generate current pulses that flow through the motor bearings, which can gradually erode the bearing races and rolling elements.

The stress on motor insulation can be avoided by using optional ABB *du/dt* filters. *du/dt* filters also reduce bearing currents. Common mode filtering mainly reduces bearing currents.

To avoid damage to the motor bearings, the cables must be selected and installed according to the instructions given in chapter [Electrical installation](#). In addition, *du/dt* filtering, common mode filtering, and insulated N-end bearings must be used according to the following table.

Motor type	Supply voltage (U_N)	Motor insulation system	Requirement		
			du/dt filtering	Insulated N-end bearing	Common mode filtering
Random-wound ABB M2_, M3_ and M4_ motors	$U_N \leq 500$ V	Any	–	–	–
Form-wound ABB HX_ or modular motor manufactured before 1 Jan 1998	$U_N \leq 500$ V	Any	Check with motor manufacturer	Yes	Yes
Random-wound ABB HX_ and AM_ motor manufactured before 1 Jan 1998	$U_N \leq 500$ V	Enamelled wire with fiberglass taping	Check with motor manufacturer		
Random-wound ABB HX_ and AM_ motor manufactured from 1 Jan 1998	$U_N \leq 500$ V	Enamelled wire with fiberglass taping	–	Yes	Yes
Other ABB motors, or random-wound or form-wound non-ABB motors	$U_N \leq 420$ V	Standard ($\dot{U}_{LL} = 1300$ V)	–	–	–
	420 V < $U_N \leq 500$ V	Standard ($\dot{U}_{LL} = 1300$ V)	Yes	–	–
		Reinforced ($\dot{U}_{LL} = 1600$ V, 0.2 microsecond rise time)	–	–	–

du/dt filters are optional accessories and to be ordered separately. For more information on common mode filtering, contact your local ABB representative. Contact the motor manufacturer for information on the motor construction.

Filter types

du/dt filters

<i>du/dt filters for ACS850-04</i>	
Drive type ACS850-04-...	Filter type
103A-5	NOCH0120-60 (1-phase*)
144A-5	
166A-5	
202A-5	NOCH0260-60 (1-phase*)
225A-5	FOCH0260-70 (3-phase)
260A-5	
290A-5	

* Three filters included in kit

Common mode filters

Contact your local ABB representative.

Technical data

du/dt filters

Dimensions and weights

Filter type	Height mm (inches)	Width mm (inches)	Depth mm (inches)	Weight kg (lbs)
NOCH0120-60*	106 (4.17)	154 (6.06)	200 (7.87)	7.0 (15.4)
NOCH0260-60*	111 (4.37)	185 (7.28)	383 (15.08)	12.0 (26.5)
FOCH0260-70	382 (15.04)	340 (13.39)	254 (10.00)	47.0 (103.6)

* Dimensions given are per phase

Degree of protection

IP00

Common mode filters

Contact your local ABB representative.

Installation

Follow the instructions included with the filters.

Further information

Product and service inquiries

Address any inquiries about the product to your local ABB representative, quoting the type designation and serial number of the unit in question. A listing of ABB sales, support and service contacts can be found by navigating to www.abb.com/drives and selecting *Sales, Support and Service network*.

Product training

For information on ABB product training, navigate to www.abb.com/drives and select *Training courses*.

Providing feedback on ABB Drives manuals

Your comments on our manuals are welcome. Go to www.abb.com/drives and select *Document Library – Manuals feedback form (LV AC drives)*.

Document library on the Internet

You can find manuals and other product documents in PDF format on the Internet. Go to www.abb.com/drives and select *Document Library*. You can browse the library or enter selection criteria, for example a document code, in the search field.

Contact us

www.abb.com/drives

www.abb.com/drivespartners

3AJUA0000045487 Rev C (EN) 2012-06-20