



# Installation and Operation Instructions

## Part # A/CS2, A/CSX2 A/SCS2, A/SCS2-L, A/SCSX2

*Please Read Instructions Carefully Before Installation!*

### **⚠ WARNING:**

- This product is not intended to be used for Life or Safety applications.
- This product is not intended for use in any hazardous or classified locations.
- The A/CS2 and A/SCS2 Series Current Switches must be used on Insulated Conductors Only!

### **⚡ HIGH VOLTAGE:**

- Disconnect and lock out all power sources before installation as severe injury or death may result from electrical shock due to contact with high voltage wires.
- Never rely on the Red LED to determine whether power is present at the current switch. At very low monitored input currents the Red LED may not light to indicate the current is above the trip point.

### **■ Installation**

Make sure that all installations are in compliance with all national and local electrical codes. Only qualified individuals that are familiar with codes, standards, and proper safety procedures for high-voltage installations should attempt installation. The current switches will not require external power, since the power for the current switch is induced from the conductor being monitored.

The current switch may be mounted in any position using the two #8 x 3/4" Tek screws and the mounting holes in the base, or snapped directly on to the 35mm DIN rail (See Figure 1). Leave a minimum distance of 1" (3 cm) between the current switch and any other magnetic devices such as contactors and transformers.

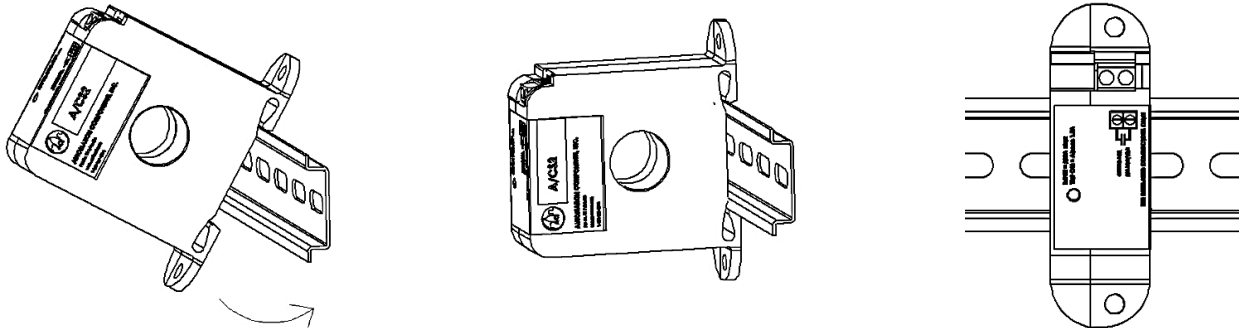
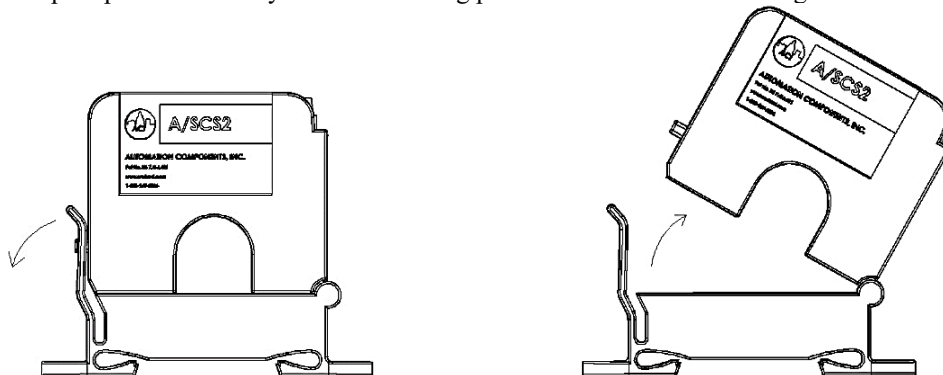

**Figure 1: Sensor Placed on Rail**

### **■ Latch Operation for A/SCS2 Series**

Press down on the side tab and swing the top of the unit up to open the split core current switch as shown in Figure 2. Press down firmly on the cover to close the current switch. An audible "click" will be heard as the tab slides over the tongue on the base.

- ⚠ CAUTION:** Mating surfaces of the magnetic core are exposed when the sensor is open. Electrical contact grease, present on the cores to prevent corrosion, can capture grit and dirt if care is not exercised. Operation can be impaired if anything prevents good contact between pole pieces. Visually check the mating parts of the core before closing the current sensor.



**Figure 2: Opening A/SCS2 Series**

■ **LED**

The Red LED will indicate whether the current is above (LED On) or below (LED Off) the fixed trip point. At very low monitored input currents the Red LED may not light to indicate the current is above the trip point.

■ **Application Notes**

The conductor being monitored may be looped through the sensor multiple times. The loops increase the current measured by the current switch. Each time the conductor passes through the current switch window equals one loop (See Figure 3 below). To determine the proper number of loops required, take the rated Fixed Trip Point (see Figure 6) of the current switch and divide it by the Operating Current of the Monitored Device, add one (1), then round up to the nearest whole number. Example: When using the A/CS2, a small fan operating at 0.1A should be wrapped through the sensor four times to give you a total operating current of 0.4 Amps flowing through the A/CS2. Formula Example:  $(0.25A/0.1A) = 2.5 + 1 = 3.5$ , which rounded up equals 4 loops.

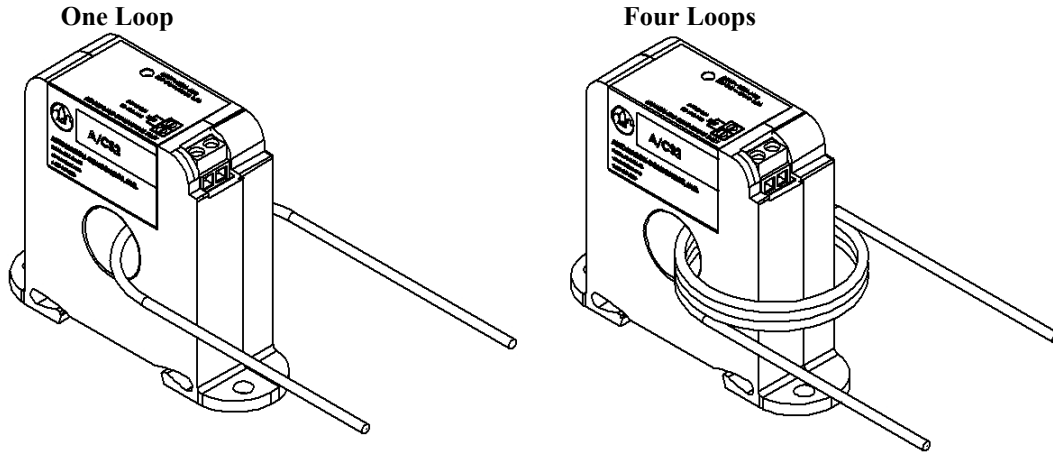

Figure 3: Wires Through Sensors

■ **Wiring**

ACI recommends the use of a two conductor 16 to 22 AWG shielded cable or twisted pair **copper wire only**, for all current switch applications. A maximum wire length of less than 30 meters (98.4 feet) should be used between the current switch and the Building Management System or controller. **Note: When using a shielded cable, be sure to connect only (1) end of the shield to ground at the controller. Connecting both ends of the shield to ground may cause a ground loop.** When removing the shield from the sensor end, make sure to properly trim the shield to prevent any chance of shorting. The current switch output terminals represent a solid-state switch for controlling both AC and DC loads and are not polarity sensitive. Tighten the screws at the terminal block connections to the recommended torque of 0.5 to 0.6 Nm (4.43 to 5.31 in-lbs.). The aperture (hole) size of the current switch is 0.75" (1.90 cm).

■ **Application Examples**

See **Figure 4** and **Figure 5** for two different current switch applications using your Building Management System (DDC/PLC Controller). **Figure 4** is showing the use of the Go/No Go Current Switch as a Digital Input to your DDC Controller, whereas **Figure 5** is showing you how to use the Go/No/Go Current Switch in conjunction with your building management system to control a fan or pump for example.

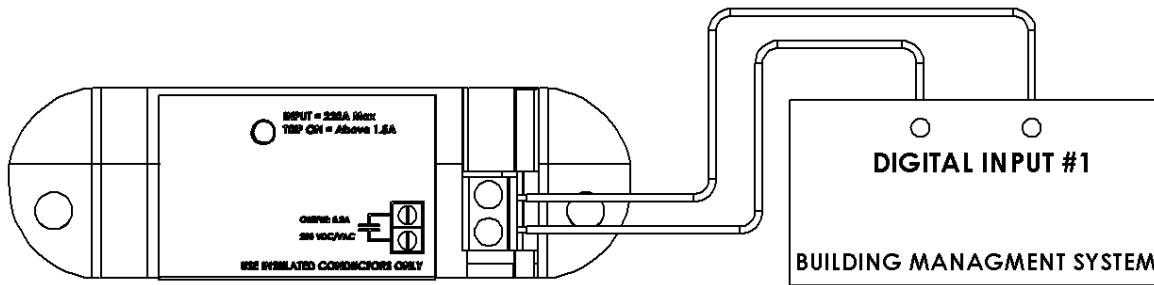

Figure 4: Digital Circuit

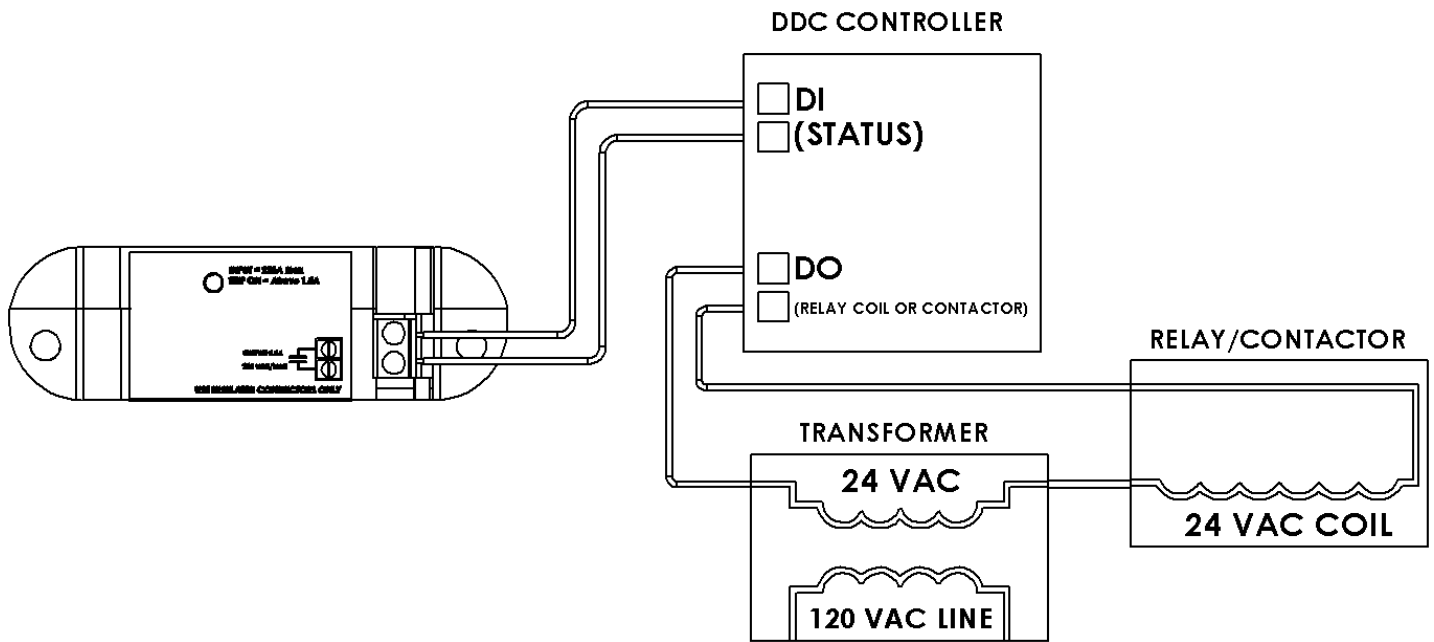

Figure 5: Analog Circuit

■ Troubleshooting

Problem	Solution
LED is on but the current switch didn't activate	Disconnect the wires from the current switch output. Measure the resistance across the contacts with an Ohmmeter. See Figure 6 for the actual resistance readings for an open or closed switch reading.
LED didn't turn on and the current switch didn't activate	Verify that the current flowing in the conductor being monitored is above the fixed trip point as listed in the operating specifications. If the sensor is monitoring less than the fixed trip point See Figure 3.
LED not on but the Current Switch is Activated	LED not indicating correctly, may have been damaged
Current Switch is operating at a low-level current or failing to operate within the accuracy specifications.	For A/SCS2 Series, visually check the mating parts of the core to ensure there is no debris between the split contacts. Remove all debris or dust manually and close the current sensor, See Figure 2. Retest the sensor in your application.

ACI Model #	Fixed Trip Point	Resistance if switch open	Resistance if switch closed
A/CS2	0.25 Amps	Greater than 1 Meg ohms	Less than 10 ohms
A/CSX2	0.25 Amps	Greater than 1 Meg ohms	Less than 10 ohms
A/SCS2	1.5 Amps	Greater than 1 Meg ohms	Less than 10 ohms
A/SCS2-L	0.5 Amps	Greater than 1 Meg ohms	Less than 10 ohms
A/SCSX2	1.5 Amps	Greater than 1 Meg ohms	Less than 10 ohms

Figure 6

■ WEEE Directive

At the end of their useful life the packaging and product should be disposed of via a suitable recycling center. Do not dispose of with household waste. Do not burn.

