

**Cover:**

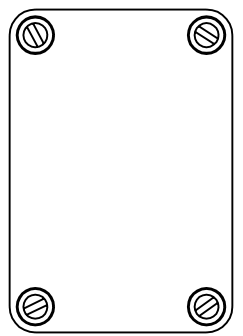

**Front View, No Cover:**

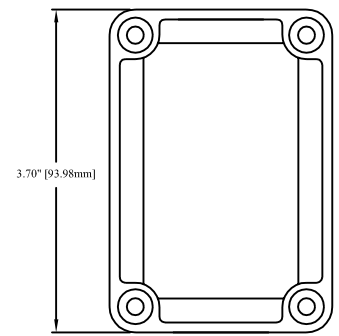

**Side View:**

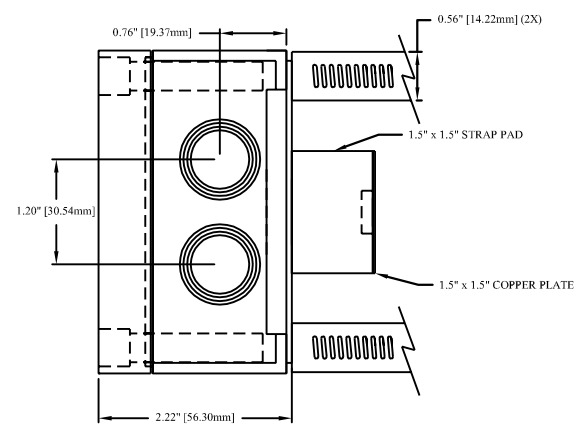

TOLERANCE: (UNLESS NOTED)  
 3 PLACE DECIMAL = ±0.010  
 2 PLACE DECIMAL = ±0.130  
 1 PLACE DECIMAL = ±0.300  
 ALL DIMENSIONS IN in[mm].  
 DRAWING NOT TO SCALE.

**WARNING!**  
 CONFIDENTIAL  
 INFORMATION--  
 PROPERTY OF ACI.  
 UNAUTHORIZED USE  
 STRICTLY FORBIDDEN.



**DRAWING NUMBER**  
 M0000038

DATE	DESCRIPTION	DRAWN BY	APPROVED BY	DRAWING NUMBER	REV
3-11-08	STRAP-ON TEMP w/ NEMA 4X BOX	DJK	TJD	M0000038	2