

A compact version of the versatile 333 Timer, the ATC 353 is its exact functional duplicate. Packaged in a 72mm<sup>2</sup> DIN-Size housing, it occupies 40% less panel space and costs proportionately less. Modern production and assembly techniques have all but eliminated hand wiring, enhancing the reliability and life expectancy of the 353.

**CONTROL VERSATILITY:** The 353 operates either as a repeat cycle pulse generator or in single-cycle interval or delayed mode. You choose the kind of control action you want by installing jumpers on the terminal block. It also provides a choice of control output. Choose a standard plug-in SPDT relay or optional SPST solid-state switch module plus an independent-24VDC output signal at Terminal 16.

**COMPUTER TESTED RELIABILITY:** The solid-state 353 is manufactured from a series of computer-tested plug-in circuit boards and assembled virtually without hand wiring. Because it has no moving parts in its logic circuits, its life expectancy is practically unlimited. Even the load relay — the 353's only significant mechanical component — has a life expectancy of 100,000,000 operations (no load), while the optional solid-state switch module has virtually unlimited life expectancy. As a result, the 353 achieves an overall reliability that surpasses even the high level achieved by previous Shawnee timers.

**SAVE 40% IN PANEL SPACE AND COST:** Packaged in a 72mm<sup>2</sup> DIN-size housing, the 353 occupies 40% less panel space than previous IC timers. Modern production and assembly techniques have substantially reduced manufacturing costs and resulted in a 45% cost saving.

**WIDE RANGE:** Each Shawnee II 353 timer covers the overall span of 0.01 SEC to 999.9 MIN in four field-convertible ranges.

**EASY TO SET:** The Shawnee timer is easily and accurately set even with work gloves on. Push any of its four toggle levers in any sequence until the number you want appears above it. You can decrease as well as increase each number by pushing the levers up or down. You can change the setting at any time, even during a cycle.

**NOISE IMMUNITY:** The 353 does not have to be shielded: its transformer power supply, full-wave bridges, buffered logic and other design characteristics render it immune to the electrical noise that is sometimes encountered in industrial environments thus eliminating false starts and reset due to voltage spikes.

**CYCLE PROGRESS INDICATION:** The Shawnee 353 indicating timer provides cycle progress indication on a four-digit display located immediately above the digital setting number wheels.

**OUTSTANDING REPEAT ACCURACY:** Unsurpassed among industrial timers regardless of cost, the Shawnee 353 has a repeat accuracy of  $\pm 10$  milliseconds on any setting within its overall range of 999.9 MIN, even in the face of wide swings in temperature or voltage and regardless of the amount of reset time between cycles.

**PLUG-IN AND DUST-TIGHT:** All 353 timers feature true plug-in design and are dust-tight from the front of panel.



*Shawnee II Digital Programmable Timer*

### MODEL NUMBER

MODEL NUMBER	353C			30	P	
<b>RANGE</b>						
999.9 SEC		346				
999.9 MIN		347				
99.99 SEC		351				
99.99 MIN		352				
Special		000				
<b>VOLTAGE &amp; FREQUENCY</b>						
120/60			A			
240/60			B			
120/50			C			
240/50			D			
<b>ARRANGEMENT</b>						
With Display (On Delay)				30		
<b>FEATURES</b>						
Basic plug-in unit					P	
Standard unit						X
Special						K

### ACCESSORIES:

Surface mounting bracket kit	353-260-27-00
Retrofit kit	305-265-61-70

The 353C Directly  
Replaces 353B & 353A  
Functional Replacement  
for the 333 Timer

**SPECIFICATIONS**

<b>RANGES</b>	Four field convertible ranges 0.01 - 99.99 SEC 0.01 - 99.99 MIN 0.1 - 999.9 SEC 0.1 - 999.9 MIN
---------------	---

<b>TIMING MODES</b>	Single cycle (interval or delayed) and repeat cycle pulse generator.
---------------------	--

**VOLTAGE REQUIREMENTS**

<b>START/RESET SIGNAL</b>	<b>VOLTAGE REQUIREMENTS</b>
Positive Polarity	Ready at 4.5V min. Reset at 1.0V max.
Negative Polarity	Ready at 3.0V min. Reset at 1.0V max
Max. Continuous Input	40V.
Ripple Voltage	must not go below minimum required
AC Line Voltage Input Impedance	5K ohms.

**RESET TIME**

Circuit Reset	1 mSEC max.
Relay Drop-Out	20 mSEC max.

**START SWITCH REQUIREMENTS (ISOLATED CONTACT)**

Switch Rating	10mA 30V
Min Open Resistance	1 megohm
Max. Closed Resistance	20K ohms

**LATCHING MODE OPERATION (INTERVAL ONLY)**

Min. Duration	50 μSEC
Start Signal	
Max. Duration	continuous
Start Signal	
Reset	when signal is removed

<b>TEMPERATURE RATING</b>	32° to 140°F (0 to 60°C)
---------------------------	--------------------------

<b>POWER REQUIREMENTS</b>	120V	95 to 132V, 50/60 Hz inrush - 0.4 A running - 0.04 A
	240V	190 to 264V, 50/60 Hz inrush - 0.2 A running - 0.02 A ±10%

<b>DC POWER SUPPLY OUTPUT (TERMINAL 7)</b>	Voltage	-24V ± 10%
	Current	40 mA max.

<b>DC OUTPUT (TERMINAL 16)</b>	Voltage	ON - -24V ± 10% OFF - -1V or less
	Current	with relay-5 mA max. without relay-40 mA max
	Impedance on	- 10 ohms max. off - 10K ohms.

<b>PULSE GENERATOR OPERATION</b>	PULSE ON TIME (with relay): 80 mSEC ± 20 mSEC (may be shortened or lengthened by installing a resistor or capacitor, respectively, across Terminals 4 and 11; see Operation Section for details.)
----------------------------------	--

<b>LOAD RELAY</b>	LIFE 100,000,000 operations (no load.) CONTACT RATING: 5A at 120V AC
-------------------	---

<b>REPEAT ACCURACY</b>	±0.01 SEC on all ranges.
------------------------	--------------------------

<b>MINIMUM SETTING</b>	99.99 SEC or MIN ranges: 0.01 SEC or MIN, respectively. 999.9 SEC or MIN ranges: 0.1 SEC or MIN, respectively.
------------------------	---

<b>MOUNTING ACCESSORIES</b>	Standard	Hardware is provided to mount timer so that it is dust-tight from front of panel.
	Optional	Surface mounting without and with front facing terminals. (See Accessory section of catalog)
	NEMA 12	NEMA 12 case (1 timer)

<b>WEIGHT</b>	NET: 1 lb., 7 oz. Shipping: 2 lbs.
---------------	------------------------------------

**DIMENSIONS (INCHES)**

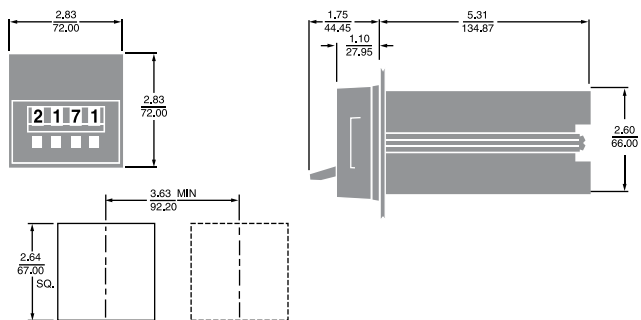

PANEL CUTOUT SHOWING DISTANCE BETWEEN ADJACENT CUTOUTS.

**WIRING**

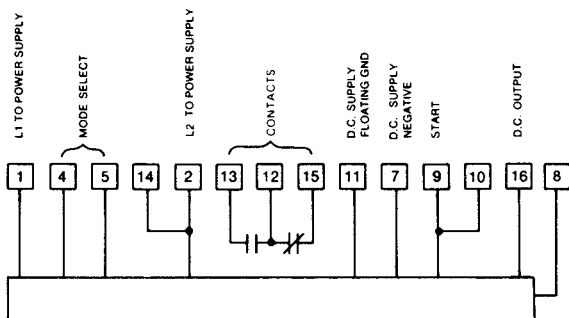

**TERMINAL WIRING**

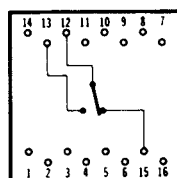

## OPERATION

The Shawnee 353 operates on a digital logic circuit with three main elements: a clock which uses utility line frequency of 50 or 60 Hz as its time base; a read-only-memory (ROM) whose output is set by the timer's digital setting number wheels; and a comparator that continuously examines the outputs of the clock and ROM.

When power is applied (start signal on), the clock begins to count each cycle of the utility line frequency. Translating this count into hundredths of a second, the clock accumulates it and feeds it continuously to the comparator. When clock output exactly equals the output of the ROM, the 353 times out.

At that instant, the clock turns itself off automatically.

At the same instant, the 353 generates one type of control action or another, depending on how it is wired.

When the 353 is wired for interval operation, the timer's output device (either the standard SPDT relay or the optional SPST switch module) is energized from the start to the end of the time cycle; so is the -24 VDC output at terminal 16.

When the 353 is wired for delayed control, the output device is energized at the end of the cycle and remains on until the timer is reset; so is the -24 VDC output.

When the 353 is wired as a repeat cycle pulse generator, the output device and the DC signal are both off until the end of the cycle, at which time they are both on for about 80 mSEC. The length of the pulse is included in the time cycle: the cycle runs from the start of one pulse to the start of the next. The 353 automatically starts a new cycle immediately after reset.

The duration of the standard output pulse generated by the 353 is 80 mSEC ( $\pm 20$  mSEC), but it can be easily lengthened or shortened by using a capacitor or resistor across terminals 4 and 11. To shorten the output pulse, the size of the resistor (fixed or variable) is calculated as follows:

Where:  $t$  = time in milliseconds ( $\pm 25\%$ )       $2.2t - 2.64$   
 $R$  = resistance in megohms       $\frac{\quad}{80-t} = R$   
 (must be at least 0.2 megohm.)

To lengthen the output pulse, the size of the capacitor is calculated as follows:

Where:  $T$  = time in seconds ( $\pm 25\%$ )       $T - 0.08$   
 $C$  = capacitance in microfarads.       $\frac{\quad}{1.6} = C$

NOTE Observe Polarity: (+) Terminal of the capacitor goes to 11, (-) Terminal to 4. To start from AC voltage, jumper terminals 8-9 and 4-11 and start with AC power at terminals 1 and 2.

## TYPICAL INSTALLATION

DELAYED MODE — Sustained\* start

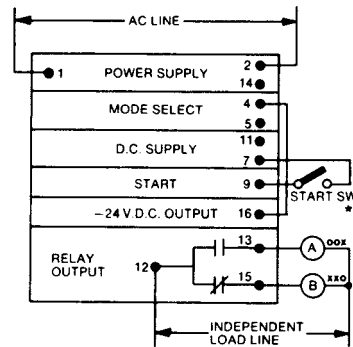

INTERVAL MODE — Sustained\* or momentary\*\* start

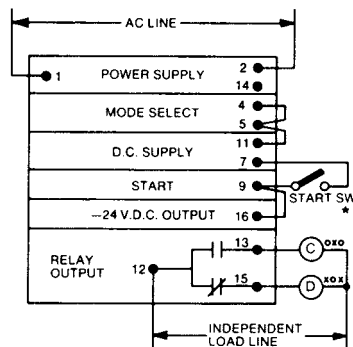

INTERVAL MODE — Sustained\* start

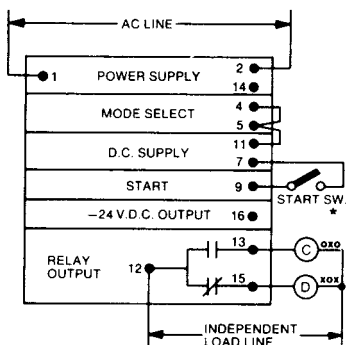

REPEAT CYCLE PULSE GENERATOR — Uninterrupted start signal

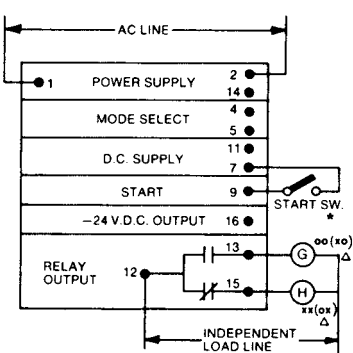

\*Start switch must be closed — or DC start signal must be on — for entire cycle. Timer resets when start switch opens or DC start signal turns off. To start from DC voltage, apply external ground on 11 and start signal on 9.

\*\*Start switch may be closed — or DC start signal may be on — for less than the entire cycle. Timer resets at end of cycle.