

SPMx00-PT2

1Q SCR Chassis Adjustable Speed Drive
for PMDC Brushed Motors

Specifications

Model	Line Voltage (VAC)	Armature Voltage Range (VDC)	Continuous Armature Current (Amps)	Horsepower Range
SPM100-3-PT2	115	0 - 90	3.0	1/8 - 1/4
SPM200-3-PT2	115	0 - 90	3.0	1/8 - 1/4

AC Line Voltage.....115/230 VAC ± 10%, 50/60 Hz, single phase
 Form Factor.....1.37 at base speed
 Acceleration Time Range.....0.25 seconds
 Deceleration Time Range.....0.25 seconds
 Load Regulation.....3% base speed or better
 Speed Range.....20:1
 Vibration (0 - 50 Hz).....0.5G maximum
 (>50 Hz).....0.1G maximum
 Ambient Temperature Range.....10°C - 55°C
 Weight.....0.24 lbs

Safety Warnings

READ ALL SAFETY WARNINGS BEFORE INSTALLING THIS EQUIPMENT

- **DO NOT INSTALL, REMOVE, OR REWIRE THIS EQUIPMENT WITH POWER APPLIED.** Have a qualified electrical technician install, adjust and service this equipment. Follow the National Electrical Code and all other applicable electrical and safety codes, including the provisions of the Occupational Safety and Health Act (OSHA), when installing equipment.
- **Circuit potentials are at 115 or 230 VAC above earth ground.** Avoid direct contact with the printed circuit board or with circuit elements to prevent the risk of serious injury or fatality. Use a non-metallic screwdriver for adjusting the calibration trim pots. Use approved personal protection equipment and insulated tools if working on this drive with power applied.
- Reduce the chance of an electrical fire, shock, or explosion by using proper grounding techniques, over-current protection, thermal protection, and enclosure. Follow sound maintenance procedures.
- **Removing AC line power is the only acceptable method for emergency stopping.** Do not use dynamic braking, decelerating to minimum speed, or coasting to a stop for emergency stopping. They may not stop a drive that is malfunctioning. Removing AC line power is the only acceptable method for emergency stopping.
- Line starting and stopping (applying and removing AC line voltage) is recommended for infrequent starting and stopping of a drive only. Dynamic braking, decelerating to minimum speed, or coasting to a stop is recommended for frequent starts and stops. Frequent starting and stopping can produce high torque. This may cause damage to motors.
- **Do not disconnect any of the motor leads from the drive** unless power is removed or the drive is disabled. Opening any one lead while the drive is running may destroy the drive.
- The field output is for shunt wound motors only. Do not make any connections to F+ and F- when using a permanent magnet motor.

Dimensions

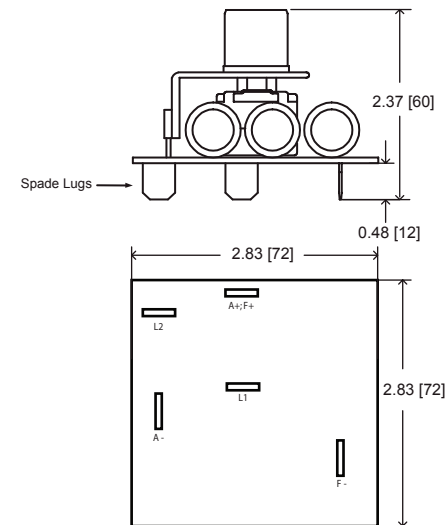

ALL DIMENSIONS IN INCHES [MILLIMETERS]

Installation

Mounting

- Drive components are sensitive to electrostatic discharge. Avoid direct contact with the circuit board. Hold the drive by the chassis or heat sink only.
- Protect the drive from dirt, moisture, and accidental contact.
- Provide sufficient room for access to the terminals and calibration trim pots.
- Mount the drive away from heat sources. Operate the drive within the specified ambient operating temperature range.
- Prevent loose connections by avoiding excessive vibration of the drive.
- Mount the drive with its board in either a horizontal or vertical plane.

Wiring

Use 14 - 16 AWG wire for AC line and motor wiring.

Shielding Guidelines

As a general rule, ACE recommends shielding of all conductors.

Fusing

ACE drives require an external line fuse for protection. Use fast acting fuses rated for 250 VAC or higher and 150% of the maximum armature current. Fuse the HOT leg of the AC line when using 115 VAC and both lines when using 230 VAC.

Connections

POWER

Line Input

Connect the AC line power leads to terminals L1 and L2.

Motor

Connect the DC armature leads to terminals A1 and A2. If the motor does not spin in the desired direction, power down the drive and reverse these connections.

Field

Connect the field leads to terminals F+ and F-.

Do not make any connections to F+ and F- if using a permanent magnet motor.

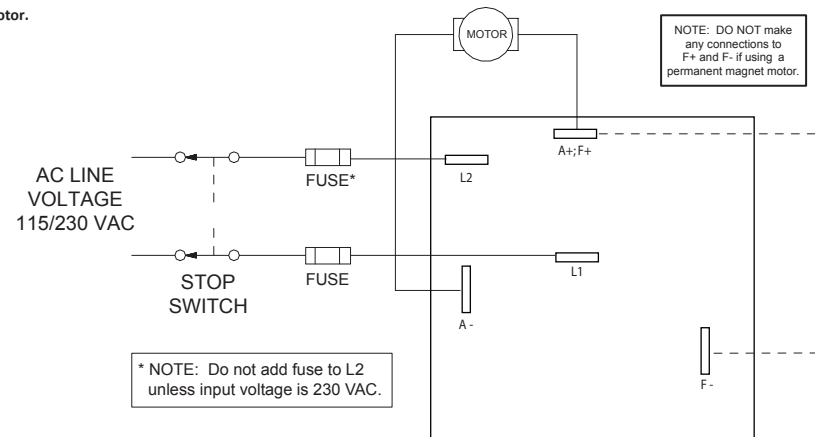

Startup

STARTUP

- Verify that no foreign conductive material is present on the printed circuit board.

1. Turn the speed adjust potentiometer full counterclockwise (CCW).
2. Apply AC line voltage. Turn the speed adjust potentiometer clockwise until it clicks. Now the unit is powered.
3. Slowly advance the speed adjust potentiometer clockwise (CW). The motor slowly accelerates as the potentiometer is turned CW. Continue until the desired speed is reached.
4. Remove AC line voltage from the drive to coast the motor to a stop.

Operation

REVERSING

Reversing with a Dynamic Brake

To reverse motor direction, set the motor for zero speed or remove the AC line. Swap the A1 and A2 terminals. **The motor must come to a complete stop before changing directions.**

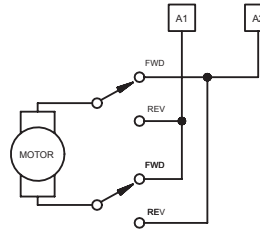

Calibration

Minimum Speed (MIN SPD): The MIN SPD setting determines the minimum motor speed when the speed adjust potentiometer is set for minimum speed. It is factory set for zero speed. To calibrate the MIN SPD:

1. Set the MIN SPD trim pot full CCW.
2. Set the speed adjust potentiometer for minimum speed.
3. Adjust the MIN SPD trim pot until the desired minimum speed is reached or is just at the threshold of rotation.

Maximum Speed (MAX SPD): The MAX SPD setting determines the maximum motor speed when the speed adjust potentiometer is set for maximum speed. To calibrate the MAX SPD:

1. Set the MAX SPD trim pot full CCW.
2. Set the speed adjust potentiometer for maximum speed.
3. Adjust the MAX SPD trim pot until the desired maximum speed is reached.

Check the MIN SPD and MAX SPD adjustments after recalibrating to verify that the motor runs at the desired minimum and maximum speed.

IR Compensation (IR COMP): The IR COMP setting determines the degree to which motor speed is held constant as the motor load changes. To calibrate the IR COMP:

1. Set the IR COMP trim pot full CCW.
2. Increase the speed adjust potentiometer until the motor runs at midspeed without load. A handheld tachometer may be used to measure motor speed.
3. Load the motor armature to its full load armature current rating. The motor should slow down.
4. While keeping the load on the motor, rotate the IR COMP trim pot until the motor runs at the speed measured in step 2. If the motor oscillates (overcompensation), the IR COMP trim pot may be set too high (CW). Turn the IR COMP trim pot CCW to stabilize the motor.
5. Unload the motor.