

Powertite™ 200 Amp Pin and Sleeve Plugs, Connectors and Receptacles

600 Vac, 250 Vdc, 50-400 Hz. Clamp Cover. Wire Recess Diameter: .687". Wire Size Range: 250 MCM-#2/0. Pressure Wire Terminals ①.

NEC/CEC:
Listed for Ordinary (Unclassified) Locations
NEMA 3, 3R, 4, 4X



Grounding Style	Wire/Pole	Receptacle with AJA Mounting Box ①	Hub Size (Inches)	Receptacle Only ②	Connector Body Only	Plug Only ③	Cable Dia. (Inches)	
Style 1 (Shell Only)	3W, 3P	AJA20033-150	1-1/2	AR20033	ARC20033CD	AP20033CD	.875 to 1.906	
		AJA20033-200	2		ARC20033E	AP20033E	1.875 to 2.500	
	4W, 4P	AJA20044-200	2	AR20044	ARC20044CD	AP20044CD	.875 to 1.906	
		AJA20044-250	2-1/2		ARC20044E	AP20044E	1.875 to 2.500	
Style 2 (Shell and Extra Pole)	2W, 3P	AJA20023-150	1-1/2	AR20023	ARC20023CD	AP20023CD	.875 to 1.906	
		AJA20023-200	2		ARC20023E	AP20023E	1.875 to 2.500	
	3W, 4P	AJA20034-150	1-1/2	AR20034	ARC20034CD	AP20034CD	.875 to 1.906	
		AJA20034-200	2		ARC20034E	AP20034E	1.875 to 2.500	
			AJA20034-250	2-1/2		ARC20034E		

For Reverse Service add suffix **-RS** to Catalog Number.
For Special Polarization, add suffix **-P4** to Catalog Number.

Pin and Sleeve Design

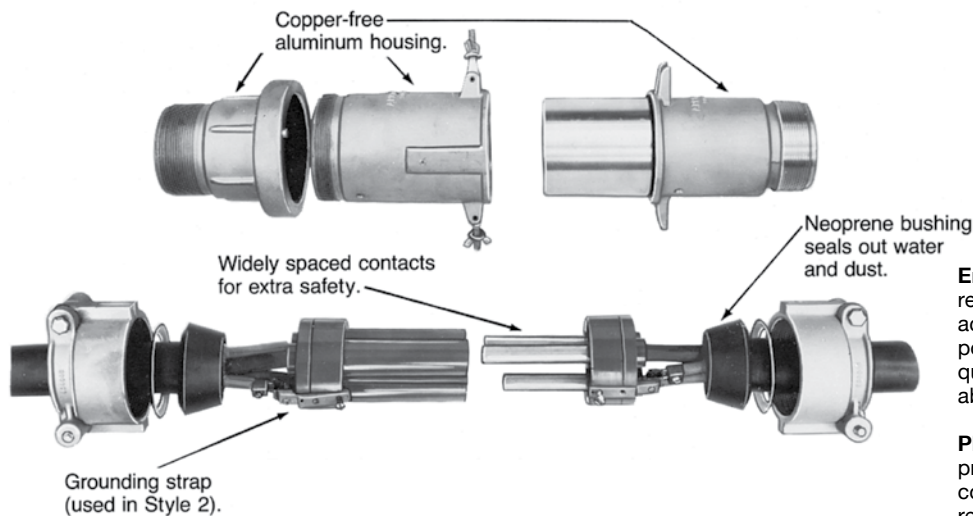

Energized contacts deeply recessed to reduce danger of accidental touching, minimize possibility of exposed arcs. Insulator quenches arcing, and is resistant to abnormal heat and to fire.

Plug mechanical cable clamps provide strain relief at conductor connections, allow easy cable replacement.

Note: Adapters for #4-#1 wire available, see Powertite™ 200 and 400 Amp Replacement Parts.

① For additional mounting boxes, see Aluminum Mounting Boxes.

② Receptacle meets NEMA 3, 3R, 4, 4X with plug fully inserted and wing nuts fully tightened or clamp cover installed with wing nuts fully tightened.

③ Plug and connector body combination is NEMA 4X rated when wing nuts are fully tightened on connector body.

PLUGS AND RECEPTACLES: NEC/CEC ORDINARY LOCATION

Appleton