

Ltr	Revision	Date
A	FROM 2.250, TO 2.265	11/22/99
B	CHANGED THICKNESS AND BENDS, WAS .52, IS .58	12/13/00
C	DELETED .18, .45 DIMENSIONS	1/02/01
D	SMALL SLOT WAS .225 R, IS .150 R	1/05/00
E	ECO 0259 ADDED MATERIAL CALLOUT AND "HALF HARD" DESIGNATION	12/2/03

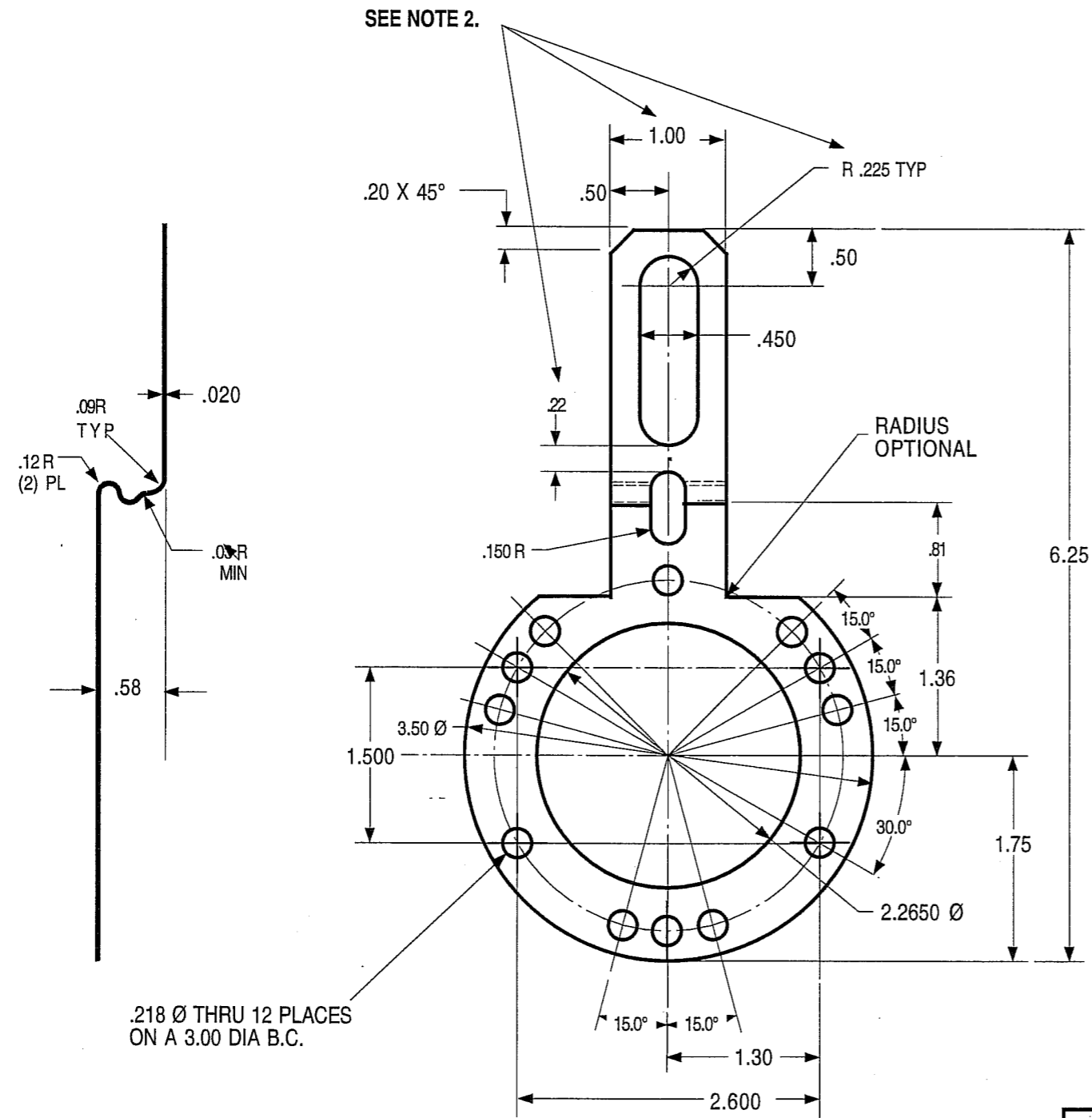

.218 Ø THRU 12 PLACES ON A 3.00 DIA B.C.

NOTES:
1.) .225 R SLOT THRU AND CUT END TO DIMENSION SHOWN.

All drawings and specifications are and remain the property of BEI Motion Systems Company. All specifications are confidential and are not to be disclosed to any persons other than those to whom they are sent. No drawings, specifications or other data belonging to BEI Motion Systems Company which may be furnished to manufacturers or others for any purpose are to be regarded by implication or otherwise as in any manner licensing the holder or any other person or corporation or conveying any rights or permission to manufacture, use or sell any patented invention that may in any way be related thereto

Unless otherwise specified:
Dimensions are in inches.
Tolerances:
XXX = .005
xx = ±.01

BEI INDUSTRIAL ENCODER DIVISION
BEI TECHNOLOGIES, INC.
7230 Hollister Avenue • Goleta, CA 93117-2891 • Tel: (805) 968-0782 • Fax: (805) 968-3154

Material
300 SERIES STAINLESS
STEEL , 25 GA (.020 INCH) HALF HARD

Drawn
App'd
DVC

TETHER ARM

Finish
NONE

Scale

Code Ident. No. 64127
Dwg. No. 924-38334-007
Rev. E

31187-005 kit	
01070-231	09178-031
Next Assy	Used on