

Next Assy	Used on	Ltr	Revision	Date
	09178-008	A	ADDED COLLET CLAMP AND SCREW	1/31/01
		B	WAS 33029-001, IS 33029-002	3/29/01

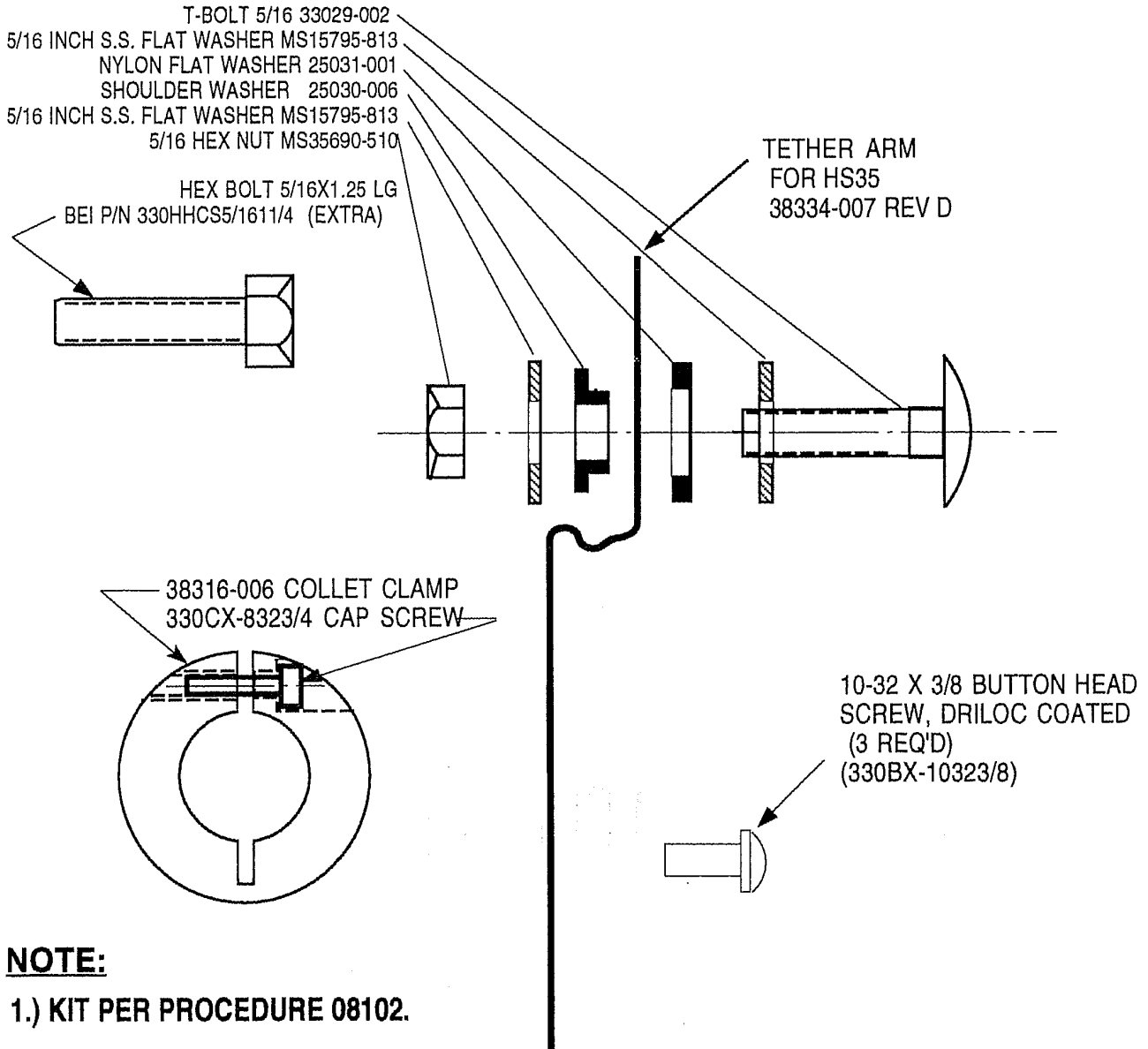

All drawings and specifications are and remain the property of BEI Motion Systems Company. All specifications are confidential and are not to be disclosed to any persons other than those to whom they are sent. No drawings, specifications or other data belonging to BEI Motion Systems Company which may be furnished to manufacturers or others for any purpose are to be regarded by implication or otherwise as in any manner licensing the holder or any other person or corporation or conveying any rights or permission to manufacture, use or sell any patented invention that may in any way be related thereto

Unless otherwise specified:
 Dimensions are in inches.
 Tolerances:
 XXX = .005
 xx = ±.01



Industrial Encoder Division

BEI SENSORS AND SYSTEMS COMPANY

7230 Hollister Avenue • Goleta, CA 93117-2891 • Tel: (805) 968-0782 • Fax: (805) 968-3154

Material	Drawn	TETHER ARM KIT, HS35-R2 FOR MOUNTING TO MOTOR FAN CAGE	
Finish	App'd <i>DVC</i>		
	Scale	Code Ident. No. 12050	Dwg. No. 924-31187-016
			Rev. B