

Relays & Volume Boosters



Type 20

Type 20 HR

Type 20 EX HR

Type 72

Type 72 HR

Type 75

Type 75 HR

Type 79

Type 79 HR



Relays - Volume Boosters

Comparison Chart

	Type 20	Type 20 HR	Type 20 EX HR
Maximum Supply Pressure	150 PSIG (10.3 BAR)	150 PSIG (10.3 BAR)	150 PSIG (10.3 BAR)
Sensitivity	1/8" H ₂ O (3.2mm)	1/8" H ₂ O (3.2mm)	1/8" H ₂ O (3.2mm)
Supply Pressure Sensitivity	0.005 PSIG (0.35 mBAR) per 25 PSIG (1.7 BAR) change in supply pressure	0.005 PSIG (0.35 mBAR) per 25 PSIG (1.7 BAR) change in supply pressure	0.005 PSIG (0.35 mBAR) per 25 PSIG (1.7 BAR) change in supply pressure
Flow Capacity	14 SCFM (400 LPM) @ 20 PSIG (1.4 BAR) signal and 100 PSIG (6.9 BAR) supply	14 SCFM (400 LPM) @ 20 psig (1.4 BAR) signal and 100 PSIG (6.9 BAR) supply	14 SCFM (400 LPM) @ 20 PSIG (1.4 BAR) signal and 100 PSIG (6.9 BAR) supply
Exhaust Capacity	2 SCFM (55 LPM) @ 5 PSIG (0.35 BAR) above a 20 PSIG (1.4 BAR) setpoint	10 SCFM (285 LPM) @ 5 PSIG (0.35 BAR) above a 20 PSIG (1.4 BAR) setpoint	15 SCFM (425 LPM) @ 5 PSIG (0.35 BAR) above a 20 PSIG (1.4 BAR) setpoint
Temperature Limits	-20 to 160 °F (-29 to 71 °C)	-20 to 160 °F (-29 to 71 °C)	-20 to 160 °F (-29 to 71 °C)
Air Consumption	8 SCFH (4 LPM)	8 SCFH (4 LPM)	8 SCFH (4 LPM)
Port Size	1/8", 1/4", 3/8" NPT, BSPP, BSPT	1/8", 1/4", 3/8" NPT, BSPP, BSPT	1/8", 1/4", 3/8" NPT, BSPP, BSPT
Output Pressure Range	2-120 PSIG (0.1 - 8.3 BAR)	2-120 PSIG (0.1 - 8.3 BAR)	2-120 PSIG (0.1 - 8.3 BAR)
Maximum Signal	120 PSIG (8.3 BAR)	120 PSIG (8.3 BAR)	120 PSIG (8.3 BAR)
Weight	1.4 lb. (0.6 kg.)	1.4 lb. (0.6 kg.)	1.4 lb. (0.6 kg.)
Ratio of Accuracy for a 12 PSIG span	<0.5%	<0.5%	<0.5%

Type 20, 20HR and 20 EXHR Flow Curve - 1/8"

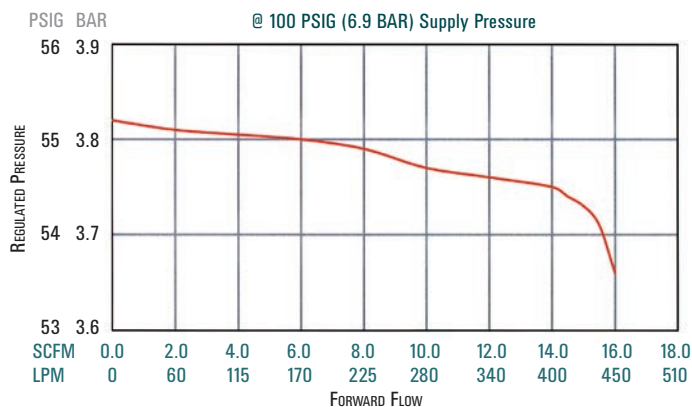

Type 72 and Typo 72 HR Flow Curves - 1/4"

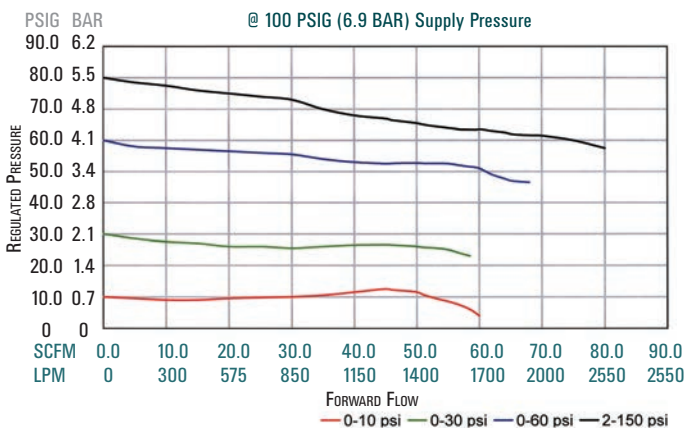

	Type 72	Type 72 HR	Type 75	Type 75 HR	Type 79/79V	Type 79HR
Maximum Supply Pressure	250 PSIG (17.2 BAR)	250 PSIG (17.2 BAR)	250 PSIG (17.2 BAR)	250 PSIG (17.2 BAR)	400 PSIG (27.6 BAR)	400 PSIG (27.6 BAR)
Sensitivity	1/4" H ₂ O (6.4mm)	1/4" H ₂ O (6.4mm)	1/4" H ₂ O (6.4mm)	1/4" H ₂ O (6.4mm)	1" H ₂ O (25mm)	1" H ₂ O (25mm)
Supply Pressure Sensitivity	< 0.6 PSIG (0.01 BAR) per 50 PSIG (1.4 BAR) change in supply pressure	< 0.6 PSIG (0.01 BAR) per 50 PSIG (1.4 BAR) change in supply pressure	< 0.6 PSIG (0.04 BAR) per 50 PSIG (6.9 BAR) change in supply pressure	< 0.6 PSIG (0.04 BAR) per 50 PSIG (3.5 BAR) change in supply pressure	<0.35 PSIG (0.02 BAR) per 100 PSIG (3.5 BAR) change in supply pressure	<0.35 PSIG (0.02 BAR) per 100 PSIG (3.5 BAR) change in supply pressure
Flow Capacity	40 SCFM (1150 LPM) @ 20 PSIG (1.4 BAR) signal and 100 PSIG (6.9 BAR) supply	40 SCFM (1150 LPM) @ 20 PSIG (1.4 BAR) signal and 100 PSIG (6.9 BAR) supply	40 SCFM (1150 LPM) @ 20 PSIG (1.4 BAR) signal and 100 PSIG (6.9 BAR) supply	40 SCFM (1150 LPM) @ 20 PSIG (1.4 BAR) signal and 100 PSIG (6.9 BAR) supply	>125 SCFM (3500 LPM) @ 20 PSIG (1.4 BAR) signal and 100 PSIG (6.9 BAR) supply	>125 SCFM (3500 LPM) @ 20 PSIG (1.4 BAR) signal and 100 PSIG (6.9 BAR) supply
Exhaust Capacity	6 SCFM (170 LPM) @ 10 PSIG (0.69 BAR) above a 20 PSIG (1.4 BAR) setpoint	15 SCFM (425 LPM) @ 10 PSIG (0.69 BAR) above a 20 PSIG (1.4 BAR) setpoint	6 SCFM (170 LPM) @ 10 PSIG (0.69 BAR) above a 20 PSIG (1.4 BAR) setpoint	15 SCFM (425 LPM) @ 10 PSIG (0.69 BAR) above a 20 PSIG (1.4 BAR) setpoint	31 SCFM (875 LPM) @ 5 PSIG (0.35 BAR) above a 20 PSIG (1.4 BAR) setpoint	39 SCFM (3500 LPM) @ 5 PSIG (0.35 BAR) above a 20 PSIG (1.4 BAR) setpoint
Temperature Limits	-40 to 200 °F (-40 to 93 °C)	-40 to 200 °F (-40 to 93 °C)	-40 to 200 °F (-40 to 93 °C)	-40 to 200 °F (-40 to 93 °C)	-40 to 200 °F (-40 to 93 °C)	-40 to 200 °F (-40 to 93 °C)
Air Consumption	<12 SCFH (5.7 LPM)	<12 SCFH (5.7 LPM)	<12 SCFH (5.7 LPM)	<12 SCFH (5.7 LPM)	<12 SCFH (5.7 LPM)	<12 SCFH (5.7 LPM)
Port Size	1/4", 3/8", 1/2" NPT, BSPP, BSPT	1/4", 3/8", 1/2" NPT, BSPP, BSPT	1/4", 3/8" NPT, BSPP, BSPT	1/4", 3/8", 1/2" NPT, BSPP, BSPT	3/8", 1/2", 3/4", 1" NPT, BSPP, BSPT	3/8", 1/2", 3/4", 1" NPT, BSPP, BSPT
Output Pressure Range	0-150 PSIG (0-10.3 BAR)	0-150 PSIG (0-10.3 BAR)	0-150 PSIG (0-10.3 BAR)	0-150 PSIG (0-10.3 BAR)	0-200 PSIG (0-13.8 BAR)	0-200 PSIG (0-13.8 BAR)
Maximum Signal	150 PSIG (10.3 BAR)	150 PSIG (10.3 BAR)	150 PSIG (10.3 BAR) for 1:1 ratio	150 PSIG (10.3 BAR) for 1:1 ratio	200 PSIG (13.8 BAR)	200 PSIG (13.8 BAR)
Weight	1.75 lb. (0.8 kg.)	1.75 lb. (0.8 kg.)	1.3 lb. (0.6 kg.)	1.3 lb. (0.6 kg.)	4.5 lb. (2.0 kg.)	4.5 lb. (2.0 kg.)
Ratio of Accuracy for a 12 psig span	< 2%	< 2%	< 2% (1:1)	< 2% (1:1)	<1.5%	<1.5%

Type 75: Regulated Pressure VS. Flow

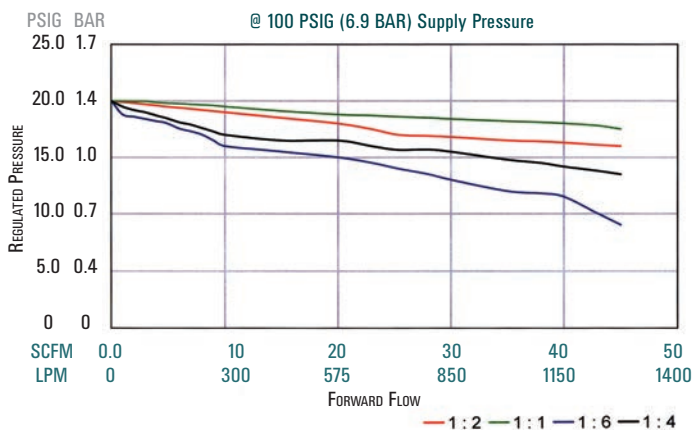

Type 79 and 79 HR: Regulated Pressure VS. Flow

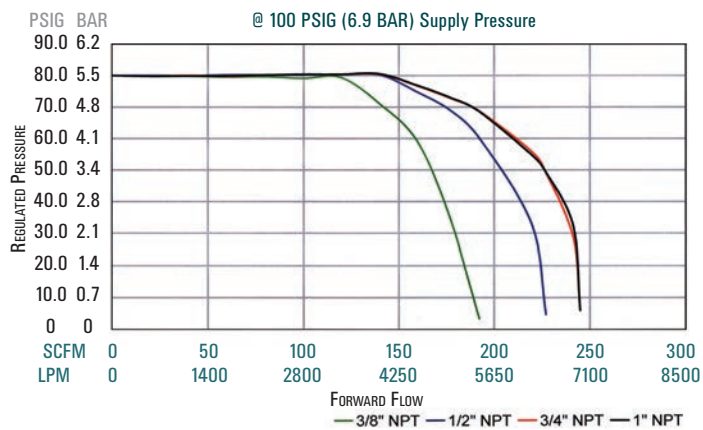

Type 20

Precision Air Relays

Features

- Extreme accuracy
- Positive and negative bias capability
- Small size
- Rugged and stable

Description

The Type 20 Air Relay is a compact, two-stage, pilot operated 1:1 relay with positive and negative bias adjustment capability. It accepts a signal pressure and combined with the bias adjustment, maintains a resulting output pressure with an accuracy and reliability unmatched by any other pressure relay in its price range.

Models

Type 20

The basic relay is offered with a choice of three port sizes.

Type 20HR and Type 20EXHR

High Relief Relays - These relays provide extra fast "blowdown" for very rapid release of output pressure. The extra relief feature makes this relay suitable for cylinder return stroke actuation, air hoists, and similar applications requiring fast exhaust.

Applications

- Gate Actuators
- Air Hoists
- Disc and Shoe Brakes
- Remote Positioning Devices
- Valve Rotors
- Control Valves
- Tensioning Systems
- Web Tracking Systems

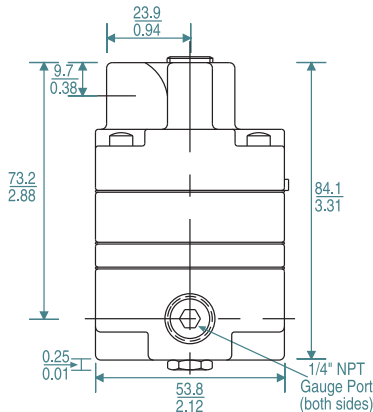
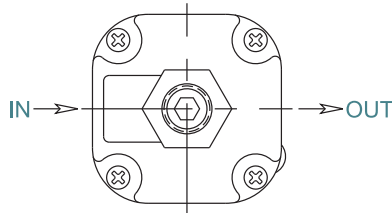

Type 20
Precision Air Relay

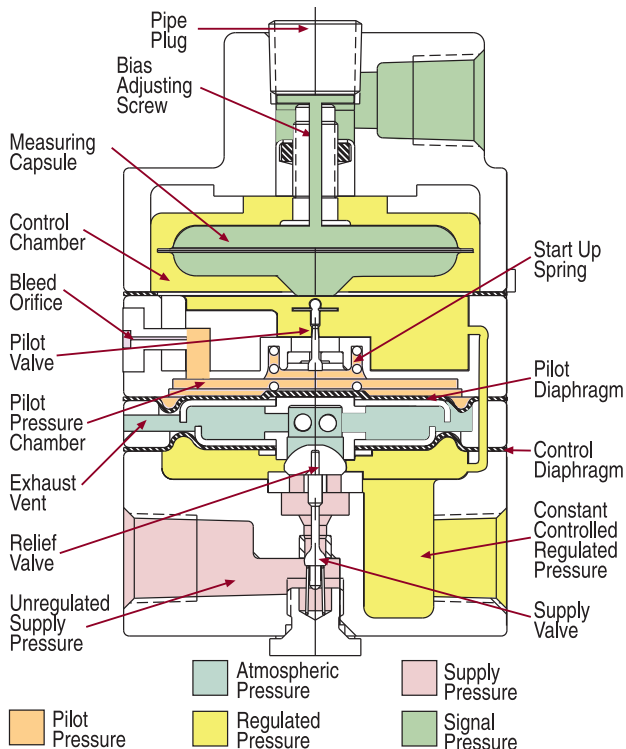

Type 20 Application Diagrams

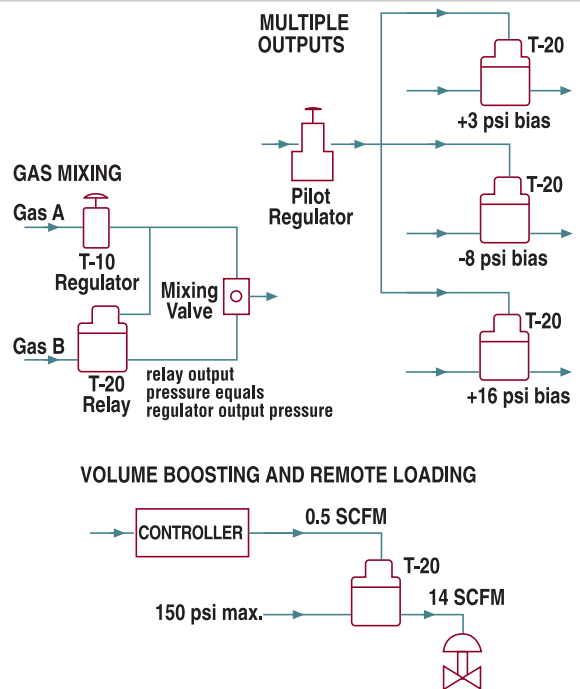

Type 72 & 72HR

Positive Bias Booster Relays

Features

- Four adjustable positive bias ranges, from 0-10 PSI (0-0.7 BAR) to 2-150 PSI (0.1-10.3 BAR)
- Flow capacity up to 50 SCFM
- Quick response to minute changes in downstream pressure
- Dampening action of aspirator tube maintains stable output pressure
- Output virtually unaffected by changes in supply pressure
- Internal rolling diaphragm designed for millions of cycles
- Honking and buzzing eliminated by action of integral baffle and aspirator tube
- Can be disassembled and serviced without removing from line
- Also available in a high relieving version (72HR)

Description

The Type 72 Relay features an adjustable bias pressure which enables users to obtain an output pressure which is the sum of a controlled input signal pressure plus the bias. The relay offers an exceptionally high flow capacity (up to 50 SCFM/1400 LPM) with minimal pressure drop.

Output pressure is accurately maintained under varying flow conditions by means of an aspirator tube, which adjusts the air supply valve opening in proportion to flow velocity. A balanced supply valve utilizing a rolling diaphragm makes the relay virtually immune to changes in supply pressure. Simple design makes maintenance easy, and the relay can be serviced without removing it from the line. The standard signal-to-output ratio is 1:1, but 1:2, 1:4 and 1:6 ratios are available on special request.

Applications

The Type 72 Relay is used when high flow capacity is required in conjunction with a positive output pressure bias. Typical applications include:

- Gas Flow Control
- Tensioning Control
- Clutch and Brake Controls
- Volume Boosting
- Dancer Roll Loading
- Calendar Roll Loading
- Cylinder Bucking Control
- Valve Motor Loading

Type 72 Dimensional Drawing

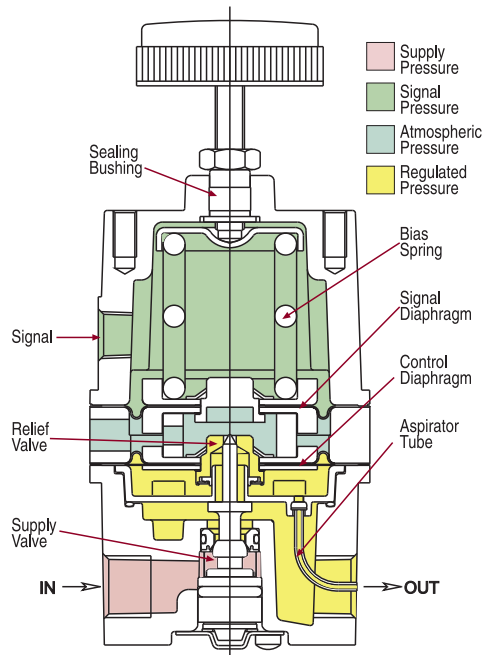
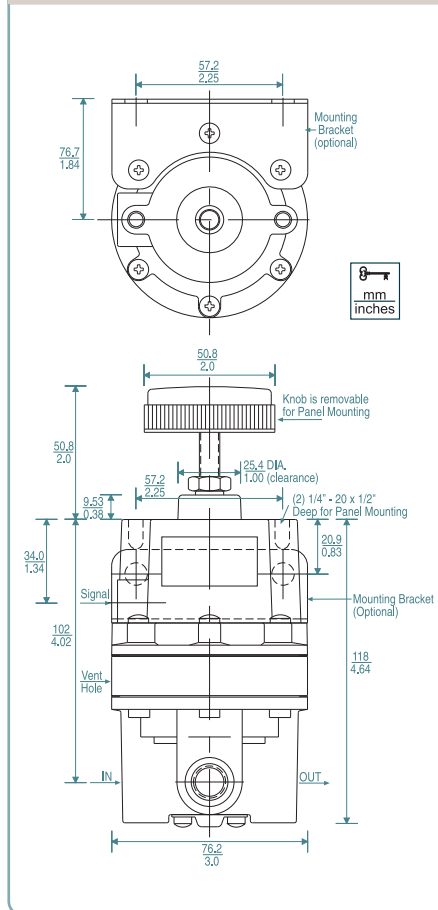

Type 72 Application Diagrams

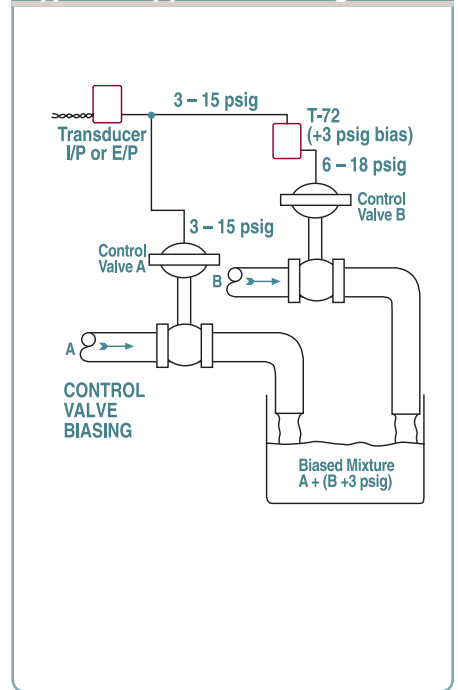

Type 75 & 75 HR

Air Relays

Features

- Balanced valve design
- High flow capacity
- Field serviceable
- Multiple output ratios
- Negative biasing option

Description

The Type 75 relay uses signal pressure to accurately control output pressure over a wide range of flow and supply pressure variation.

Under varying flow conditions output pressure is maintained by use of an aspirator tube, which adjusts the air supply valve opening in accordance with the flow velocity. A balanced supply valve, utilizing a rolling diaphragm, makes the relay virtually immune to changes in supply pressure. Maintenance is simple due to the unit construction, and the relay can be serviced without removing it from the line. Signal to output pressure ratios of 1:1, 1:2, 1:4 and 1:6 are available. Maximum output is 150 PSIG (10.3 BAR).

Applications

- Volume Boosting
- Dancer Roll Loading
- Calendar Roll Loading
- Cylinder Bucking Control
- Clutch and Brake Controls
- Gas Flow Control
- Tensioning Control
- Valve Motor Loading

Models

Type 75

The basic relay offers excellent precision along with high forward flow rates.

Type 75 High Relief Relays

These relays provide extra fast "blowdown" for very rapid release of output pressure. The extra relief feature makes this relay suitable for cylinder return stroke actuation, air hoists, and similar applications requiring fast exhaust.

Type 75 Negative Bias

The Type 75 Relay is also available with a 4 ± 1 psig (0.3 ± 0.07 BAR) negative bias spring mounted internally. (See cross-sectional drawing on previous page.) This bias spring automatically subtracts 4 ± 1 psig (0.3 ± 0.07 BAR) from any signal pressure introduced. The relay then multiplies the net signal pressure by its ratio value to obtain final output pressure.

This option is particularly useful in obtaining zero pressure from pneumatic devices such as I/P transducers that normally cannot be adjusted this low, as well as obtaining higher outputs from such devices.

Typical applications of the Type 75 Relay with fixed negative bias include the electronic control of the applications listed for the standard Type 75 Relay.

To calculate relay output:

Relay output = (signal pressure) - 4 PSI bias x (relay ratio factor) where the relay ratio factor is defined as follows:

Relay Ratio	Factor
1:1	1
1:2	2
1:4	4
1:6	6

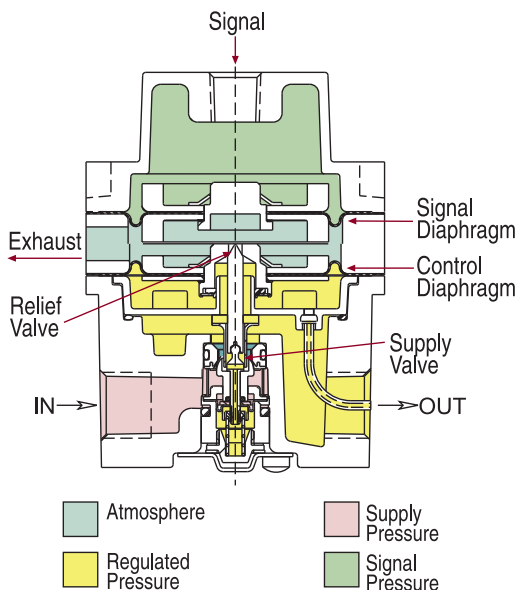

Type 75
Air Relay



Type 75 Application Diagrams

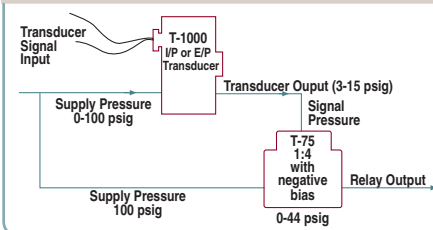

Type 75 Dimensional Drawing

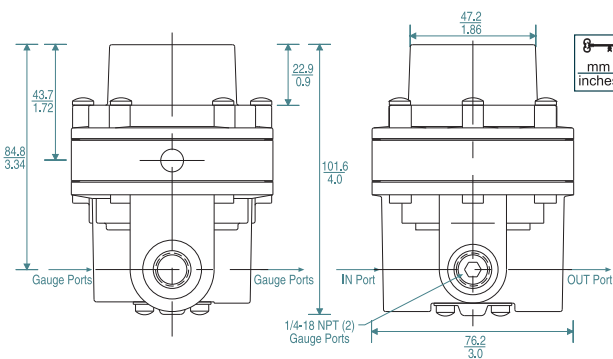

Type 79

High Flow Air Relays

Features

- Balanced pintle
- High flow capacity
- Field serviceable
- Large port sizes available
- Air piloted or dome loaded
- 200 PSIG output
- Also available in a high relieving version (Type 79HR)

Description

The Type 79 1:1 Ratio High Flow Precision Air Relay brings additional precision and control to the Bellofram line of precision control products.

The Type 79 relay is designed for applications where a precise control of flow is needed. This regulator offers low droop, high accuracy and fine adjustment sensitivity. The use of a Bellofram rolling diaphragm provides greater sensitivity and improved accuracy. The balanced pintle minimizes output pressure changes caused by fluctuations in supply pressure.

Careful design and quality materials throughout assure long, trouble-free operation. The rugged die-cast zinc and aluminum housings are pressure tested to assure safe

operation. The Type 79 is designed to withstand harsh and abusive environments. This is attributed to a chemical conversion coating of all cast components, and a vinyl paint finish.

The Type 79 can achieve flow rates of well over 200 SCFM (5695 LPM). This relay can be pipe or bracket mounted.

A version of the Type 79 for valve control applications is available. The Type 79V utilizes soft exhaust seats to minimize air consumption, increased deadband to ignore valve oscillations, and an integral bypass valve that can be 'tuned' for optimum valve response.

Applications

- Clutch and Brake Controls
- Gas Flow Control
- Cylinder Bucking Control
- Tension Control
- Dancer (Calendar) Roll Loading
 - Volume Boosting
 - Valve Motor Loading



Type 79
High Flow Air Relay

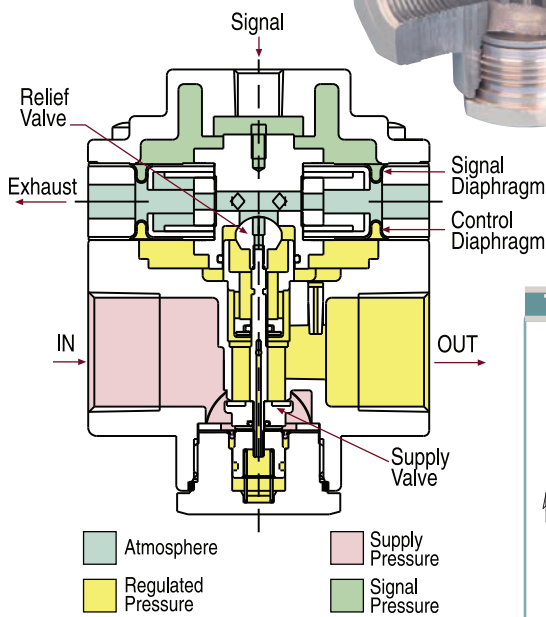
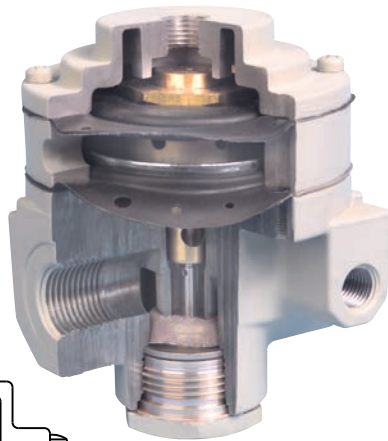

Type 79 Application Diagrams

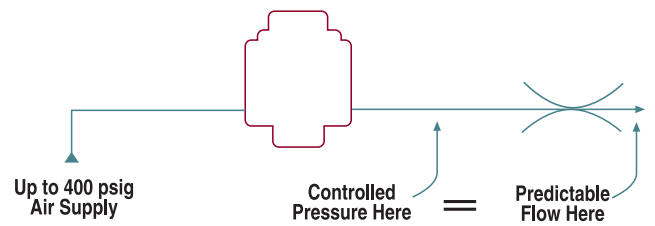

Type 79 Dimensional Drawing

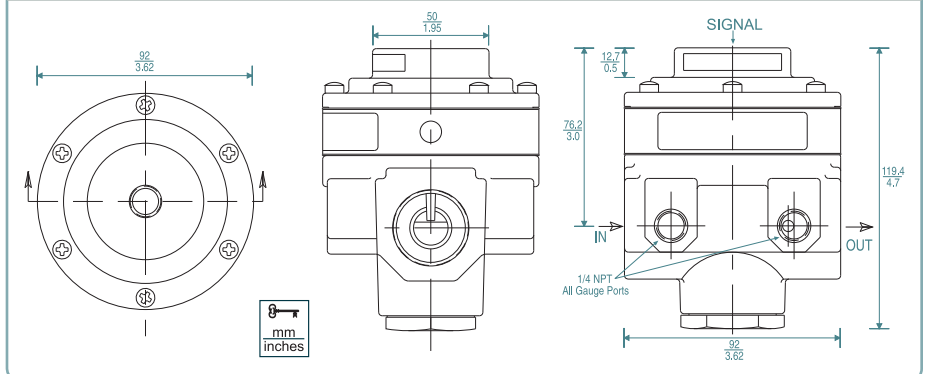

Volume Booster Ordering Information

	Ratio	Port Size (NPT)	Set Point Range		Part Number
			BAR	PSIG	
Type 20 Precision Relay	1:1	1/8	0.1-8.3	2-120	961-004-000
		1/4	0.1-8.3	2-120	961-005-000
		3/8	0.1-8.3	2-120	961-006-000
Type 20HR Precision Relay High Relief Capacity	1:1	1/8	0.1-8.3	2-120	961-001-000
		1/4	0.1-8.3	2-120	961-002-000
		3/8	0.1-8.3	2-120	961-003-000
Type 20 EXHR	1:1	1/8	0.1-8.3	2-120	961-009-000
		1/4	0.1-8.3	2-120	961-010-000
		3/8	0.1-8.3	2-120	961-011-000
Type 72 Positive Bias Booster Relay	1:1	3/8	0-0.7	0-10	961-062-000
		3/8	0-2.1	0-30	961-063-000
		3/8	0.07-4.1	1-60	961-064-000
		3/8	0.1-10.3	2-150	961-065-000
		1/4	0-0.7	0-10	961-052-000
		1/4	0-2.1	0-30	961-053-000
		1/4	0.07-4.1	1-60	961-054-000
		1/4	0.1-10.3	2-150	961-055-000
Type 72 HR High Relief Positive Bias Booster Relay	1:1	3/8	0-0.7	0-10	961-182-000
		3/8	0-2.1	0-30	961-183-000
		3/8	0.07-4.1	1-60	961-184-000
		3/8	0.1-10.3	2-150	961-185-000
		1/4	0-0.7	0-10	961-178-000
		1/4	0-2.1	0-30	961-179-000
		1/4	0.07-4.1	1-60	961-180-000
		1/4	0.1-10.3	2-150	961-181-000
Type 75 Precision Relay	1:1	1/4	0-10.3	0-150	961-058-000
	1:1	3/8	0-10.3	0-150	961-066-000
	1:2	1/4	0-10.3	0-150	961-059-000
	1:2	3/8	0-10.3	0-150	961-067-000
	1:4	1/4	0-10.3	0-150	961-060-000
	1:4	3/8	0-10.3	0-150	961-068-000
	1:6	1/4	0-10.3	0-150	961-045-000
	1:6	3/8	0-10.3	0-150	961-069-000
Type 75 Precision Relay Fixed Negative Bias (4 PSI)	1:1	1/4	0-10.3	0-150	961-090-000
	1:1	3/8	0-10.3	0-150	961-091-000
	1:2	1/4	0-10.3	0-150	961-092-000
	1:2	3/8	0-10.3	0-150	961-093-000
	1:4	1/4	0-10.3	0-150	961-094-000
	1:4	3/8	0-10.3	0-150	961-095-000
Type 75HR Precision Relay	1:1	1/4	0-10.3	0-150	961-096-000
	1:1	3/8	0-10.3	0-150	961-097-000
	1:1	1/2	0-10.3	0-150	961-144-000
	1:1	3/8	0-10.3	0-150	961-145-000
	1:2	1/4	0-10.3	0-150	961-146-000
	1:2	3/8	0-10.3	0-150	961-147-000
Type 75HR Precision Relay Fixed Negative Bias (4 PSI)	1:1	1/4	0-10.3	0-150	961-148-000
	1:1	3/8	0-10.3	0-150	961-149-000
	1:1	1/2	0-10.3	0-150	961-150-000
	1:1	3/8	0-10.3	0-150	961-151-000
	1:2	1/4	0-10.3	0-150	961-152-000
	1:2	3/8	0-10.3	0-150	961-153-000
Type 79 High Flow Capacity	1:1	3/8	0-13.8	0-200	961-154-000
		1/2	0-13.8	0-200	961-155-000
		3/4	0-13.8	0-200	961-156-000
		1	0-13.8	0-200	961-157-000
		3/4	0-13.8	0-200	961-158-000
Type 79 HR High Relief High Flow Capacity	1:1	3/8	0-13.8	0-200	961-159-000
		1/2	0-13.8	0-200	962-378-000
		3/4	0-13.8	0-200	962-378-100
		1	0-13.8	0-200	962-378-200
Type 79V	1:1	3/8	0-13.8	0-200	962-378-300
		1/2	0-13.8	0-200	961-200-000
		3/4	0-13.8	0-200	961-201-000
		1	0-13.8	0-200	961-202-000

Type 20 Option Ordering Matrix

Replace last three digits of part number with digits from table below.

Option	8
8 Pressure Gauge	008

Type 72 Option Ordering Matrix

Replace last three digits of part number with digits from table below.

Option	3	5	7	8	9
3 Square Head	003	053	073	083	
5 Epoxy Finish		005	075	085	095
7 Mounting Bracket			007	087	097
8 Pressure Gauge				008	098
9 Tamper-Resistant Cover					009

Type 75 Option Ordering Matrix

Replace last three digits of part number with digits from table below.

Option	5	7	8
5 Epoxy Finish	005	075	085
7 Mounting Bracket		007	087
8 Pressure Gauge			008

Type 79 Option Ordering Matrix

Replace last three digits of part number with digits from table below.

Option	1	2	5	6	7
1 Low Bleed	001		051	061	071
2 Non-Relieving		002	052	062	072
5 Epoxy Finish			005	065	075
6 Tapped Vent				006	076
7 Tapped Supply Port					007

Relay Options and Accessories

Pressure Gauge

Dual scale (English and Metric) 2 inch (50.8 mm) gauges are available

Epoxy Finish - Gray epoxy coating for greater corrosion resistance.

Mounting Bracket

Zinc-plated steel bracket for side mounting.

(For Type 79 order part number 607-293-000)

(For Type 75 order part number 607-000-047)

Tamper Resistant Cover

A cover placed over the adjusting screw to prevent ordinary hand adjustments.

Low Bleed

Reduces steady-state air consumption by approximately 50%.

Non-Relieving

Used in applications where it is desirable to relieve pressure downstream of the relay. Non-relieving relays should not be used for low or no flow applications.

Tapped Vent (Exhaust)

1/4 NPT tapped port to allow for installation of plumbing to capture exhaust air.

Tapped Supply Gauge Port

1/4 NPT tapped port is offered as a pressure tap for monitoring the inlet or upstream pressure supplied to the regulator. (Type 79 only)

BSPP or BSPT

British Standard Threads can be ordered by adding either "BSPT" or "BSPP" to the end of the part number.