

# Diaphragm Air Cylinders



Small bore  
Cylinders

Standard  
Cylinders

Super  
Cylinders



# Diaphragm Air Cylinders

## Features

- Low start up pressure
- Low breakaway force
- Extremely sensitive response
- Very smooth, "non-jarring" action
- Wide temperature range
- Very low friction
- No edge seals to replace
- No blow-by leakage
- Numerous varieties
- Low total cost

## Description

Diaphragm Air Cylinders are actuators made from elastomers, engineered metals and fabrics. They require no lubrication, are virtually frictionless, and economical. They can be used to provide lifting, clamping, pushing, coining, turning, and other linear force or actuation motions in many applications.

The development of the long stroke rolling diaphragm for dynamic sealing proved to be the solution for many applications requiring low friction, no lubrication, low leakage, wide temperature variations, and low total cost. The popularity of the rolling diaphragm as a sealing means led to many requests for a standard line of "off the shelf" diaphragm cylinders; single and double acting, short and long stroke with a wide selection of effective areas. To meet these requests, the long stroke rolling diaphragm cylinder was developed and Bellofram has supplied many thousands of them since their 1965 introduction.

## Applications

Diaphragm Air Cylinder applications are almost unlimited. They are replacing conventionally sealed cylinders and actuators where low cost and reliability are requirements. They can be used with vacuum and gaseous pressure systems. They are currently solving many unique problems, being used as:

- Expansion Chambers
- Accumulators
- Pumps
- Reservoirs
- Shock Mounts
- Impact Absorbers
- Weld Drivers
- Tensioners
- Dancer Rolls
- Valve Actuation
- Louver Controls

## Standard Cylinders

Standard Bellofram Air Cylinders are available in eight sizes. Each size is available in both a spring-return and a double-acting variety, with one or two stroke variations (Series E or F).

Sizes 4 and 6 have impact-extruded aluminum shells. Larger sizes have steel shells. Rods are ground, polished and hard-chrome plated steel. Bearings are sintered bronze, molybdenum disulphite impregnated. Other components are high strength materials with suitable corrosion resistant treatment.

- Bellofram engineers will help you define your specific needs.
- All Standard cylinders can be ordered with either no spring, or no bearing, as standard options.
- Standard cylinders can be ordered with one of six different mounting options.
- Specifications for Standard cylinders are shown in the table on the next page.

## Super Cylinders

Bellofram Super Cylinders are standard spring-return cylinders equipped with linear ball bearings and hardened steel rods. This refinement allows an absolute minimum of friction for applications where maximum sensitivity is needed.

Super Cylinders are available only in spring-return varieties and in Series F stroke variations.

All mounting options offered on standard cylinders are also available on super cylinders.



Diaphragm Air Cylinder



## Cylinder Weights

Cat. No.	Lbs.	Cat. No.	Lbs.	Cat. No.	Lbs.	Cat. No.	Lbs.
S-4-F-BP	4	S-16-E-BP	13	D-4-F-BP	4	D-16-E-BP	14
S-4-BP-N	5	S-16-F-BP	14	D-4-BP-N	5	D-16-F-BP	16
S-6-F-BP	5	S-24-E-BP	18	D-6-F-BP	5	D-24-E-BP	20
S-6-BP-N	6	S-24-F-BP	25	D-6-BP-N	6	D-24-F-BP	28
S-9-F-BP	8	S-30-E-BP	25	D-9-F-BP	8	D-30-E-BP	26
S-9-BP-N	9	S-30-F-BP	31	D-9-BP-N	9	D-30-F-BP	33
S-12-E-BP	9	S-36-E-BP	28	D-12-E-BP	10	D-36-E-BP	29
S-12-F-BP	11	S-36-F-BP	36	D-12-F-BP	12	D-36-F-BP	39

## Standard and Super Cylinder Specifications

Plant Air	Up to 145 PSIG (10 BAR)
Temperatures	-40 ° to 225 ° F (-40 ° to 107 ° C)
Materials of Construction	<p><b>Body:</b> Sizes 4 and 6 are impact-extruded aluminum shell. Larger sizes are made from a steel shell.</p> <p><b>Diaphragm:</b> Neoprene® elastomer reinforced with Flex-Weave Dacron® fabric.</p> <p><b>Rods:</b> Ground, polished and hard-chrome plated steel.</p> <p><b>Bearings:</b> Sintered bronze, molybdenum disulphite impregnated.</p> <p>Other components are high strength materials with suitable corrosion resistant treatment.</p>
Testing	All cylinders are leak-tested prior to shipment. However, the cylinder is not a bubble tight assembly

### Standard and Super Cylinder Operating Data

Size (Effective Area) (Sq. Inches)	Equivalent Bore Diam. (Inches)	Spring Return						Double Acting	
		Stroke +.03/- .12 (Inches)	Stroke +.03/- .12 (Inches)	Approx. Spring Force - Zero Stroke (lbs.)		Approx. Increase Force Per Inches of Stroke (lbs.)		Stroke +.03/- .12 (Inches)	Stroke +.03/- .12 (Inches)
		Series E	Series F	Series E	Series F	Series E	Series F	Series E	Series F
4	2.3		1.80		6		3		1.3
6	2.8		2.40		9		4		1.9
9	3.4	2.20	3.00	17	12	4	4		2.5
12	3.9	2.30	3.60	18	18	6	6	1.8	3.1
16	4.5	2.62	4.20	24	24	8	8	2.1	3.7
24	5.5	2.60	5.24	36	36	11	11	2.0	4.6
30	6.3	3.07	6.00	45	54	13	14	2.4	5.4
36	6.8	3.55	6.00	54	54	16	14	2.9	5.4

## Small Bore Cylinders

Bellofram's 0.38 and 1.7 sq. inch effective area diaphragm cylinders combine the performance of the diaphragm cylinder with small size. Two different stroke options are available in each size, with either flush or extended rods on 0.38 sq. inch cylinders. Only spring return varieties are available.

### Specifications

0.38 sq. inch Cylinders have aluminum alloy shells and end caps, and carbon steel rods. 1.7 sq. inch Cylinders have die-cast aluminum shells and end caps, and chrome-plated carbon steel rods. All varieties have oil-impregnated bronze bearings, polyester fabric reinforced nitrile diaphragms, and music wire springs. Optional foot mounts are available for the 1.7 sq. inch Cylinders.



Marsh Bellofram offers very smooth, "Non-Jarring" action in a Low Cost Cylinder

External stroke limiters should be provided by the customer to limit the stroke in both directions on both single-acting and double-acting cylinders.

Installation and operation procedures furnished with each cylinder should be followed for maximum service life.



### Small Bore Cylinder Operating Data

Part Number	Size (Effective Area) Sq. In.	Stroke In.	Load @ 0 Stroke Lbs.	Spring Load @ Max. Stroke Lbs.	Equiv. Bore Dia. In.	Maximum Operating Press. PSI	Rod Type
908-013-000	0.384	0.70	2	7	0.7	125	Flush
908-034-000	0.384	0.70	2	7	0.7	125	3/4"
908-014-000	0.384	0.32	5	7	0.7	125	Flush
908-035-000	0.384	0.32	5	7	0.7	125	3/4"
980-008-000	1.7	1.0	4	8	1.5	125	—
980-077-000	1.7	1.75	4	11	1.5	125	—

### Cylinder Replacement Parts

When ordering replacement parts, provide nomenclature of part from photographs in addition to the following information from the nameplate on the cylinder: Type, Size, Series, and Rod type.

Complete kits are available for replacement of diaphragm or bearings.

### Spring Return Cylinders (Super Cylinder Shown)

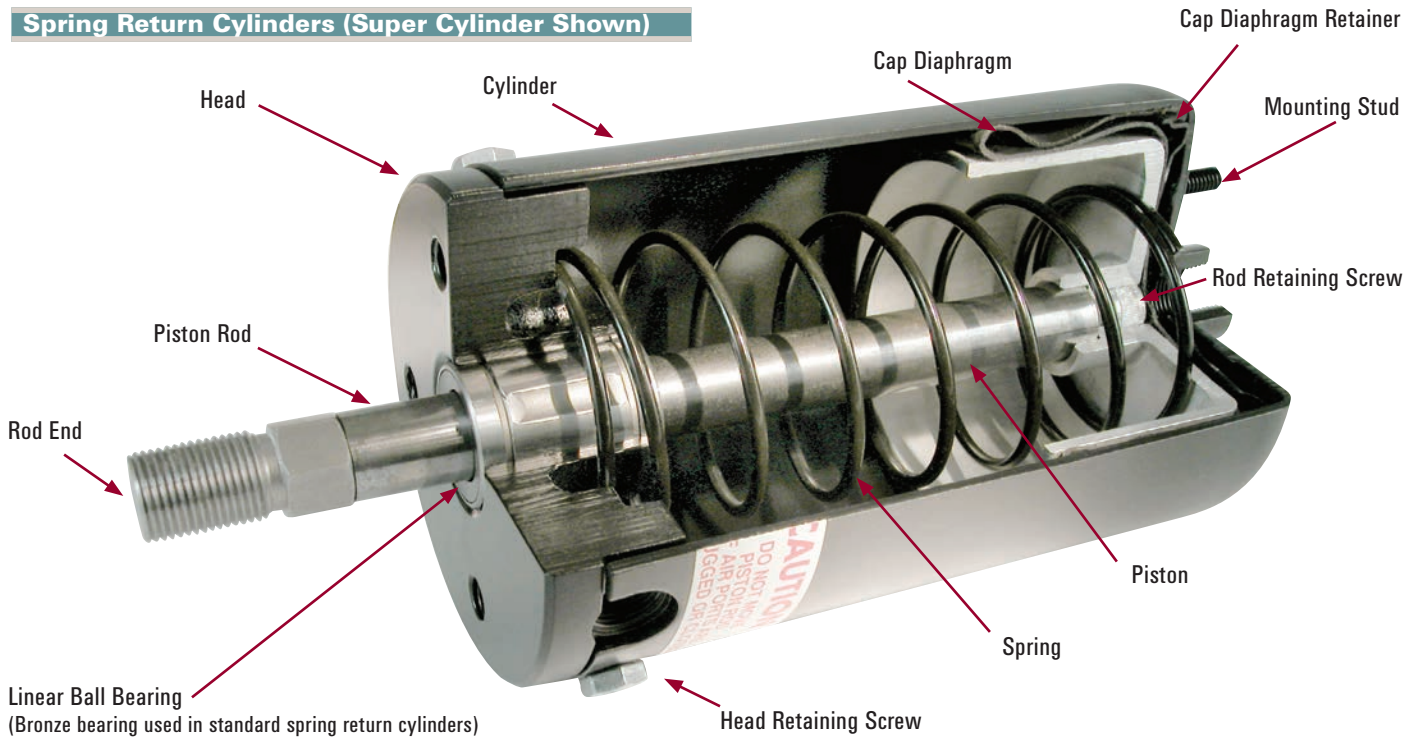

### Double Acting Cylinders

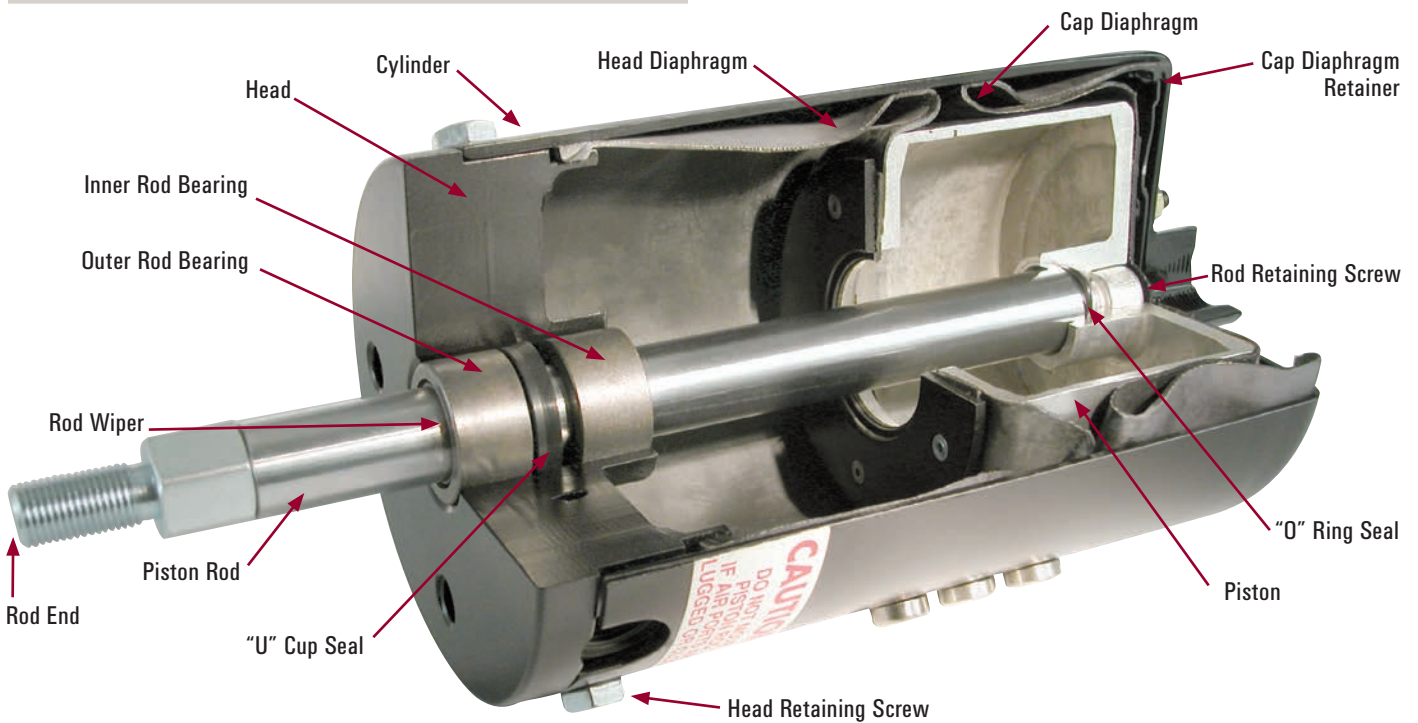

## Standard Cylinders Ordering Information

↑	↑	↑	↑	↑	↑	Type
<b>S</b>						Spring Return
<b>D</b>						Double Acting
						<b>Size</b>
	<b>04</b>					4 Square Inches
	<b>06</b>					6 Square Inches
	<b>09</b>					9 Square Inches
	<b>12</b>					12 Square Inches
	<b>16</b>					16 Square Inches
	<b>24</b>					24 Square Inches
	<b>30</b>					30 Square Inches
	<b>36</b>					36 Square Inches
						<b>Series</b>
	<b>E</b>					Determines Stroke
	<b>F</b>					Determines Stroke
						Make a selection from Operating Data Table on pg. 47
						<b>Rod</b>
		<b>BP</b>				Bellofram Product Standard
		<b>SM</b>				National Fluid Power Assoc. Standard
						Make a selection from dimensional data tables on pgs. 51-54
						<b>Mounting</b>
			<b>N</b>			Nose Mount
			<b>UM</b>			Universal Mount
			<b>FM</b>			Foot Mount
			<b>CFM</b>			Cap Flange Mount
			<b>HFM</b>			Head Flange Mount
			<b>CBM</b>			Clevis Bracket Mount
			<b>CBS</b>			Clevis Bracket Stud
						<b>Standard Options</b>
				<b>NS</b>		No Spring
				<b>NB</b>		No Bearing
				<b>NBS</b>		No Bearing or Spring
						No Standard Option Requested

Example: D-12-F-BP-CBM is a Double Acting, 12 sq. in., 3.1" Stroke, BP Rod End Cylinder with Clevis Bracket Mount.

## Super Cylinders Ordering Information

SS	↑	F	↑	↑	↑	Type
<b>SS</b>						Super Cylinders
						<b>Size</b>
	<b>04</b>					4 Square Inches
	<b>06</b>					6 Square Inches
	<b>09</b>					9 Square Inches
	<b>12</b>					12 Square Inches
	<b>16</b>					16 Square Inches
	<b>24</b>					24 Square Inches
	<b>30</b>					30 Square Inches
	<b>36</b>					36 Square Inches
						<b>Series</b>
		<b>F</b>				Determines Stroke
						Make a selection from Operating Data Table on pg. 47
						<b>Rod</b>
			<b>BP</b>			Bellofram Product Standard
			<b>SM</b>			National Fluid Power Assoc. Standard
						Make a selection from dimensional data table on pgs. 51-54
						<b>Mounting</b>
				<b>UM</b>		Universal Mount
				<b>FM</b>		Foot Mount
				<b>CFM</b>		Cap Flange Mount
				<b>HFM</b>		Head Flange Mount
				<b>CBM</b>		Clevis Bracket Mount
				<b>CBS</b>		Clevis Bracket Stud
						<b>Standard Options</b>
				<b>NS</b>		No Spring
						No Standard Option Requested

Example: SS-12-F-SM-HFM is a Single Acting Super Cylinder, 12 sq. in., 3.6" stroke, SM Rod End Cylinder with a Head Flange Mount.

## Repair Kits

Repair Kits are available to permit user in-plant maintenance without delay and expense of returning parts to the factory. Each kit includes installation instructions. Nameplate data of the cylinder must accompany order to insure receipt of correct parts.

The following is included in the repair kits:

### Spring Return Diaphragm Kit

1. Diaphragm, Cap
2. Adhesive, Cap
3. Nuts, Cap Retainer
4. Instructions

### Spring Return Bearing Kit

1. Inner Bearing
2. Outer Bearing
3. Rod Wiper
4. Instructions

### Double Acting Diaphragm Kit

1. Diaphragm, Cap
2. Diaphragm, Head
3. Adhesive, Cap
4. Adhesive, Head
5. Rivets, Blind (or Screws)
6. Nuts, Cap Retainer
7. Seal "O" Ring
8. Instructions

### Double Acting Bearing Kit

1. Inner Bearing
2. Outer Bearing
3. Rod Wiper
4. U-Cup Seal
5. Instructions

## Breather Vents

Breather vents are available for use on Bellofram Spring Return Air Cylinders.

The Breather, which contains a 40 micron bronze filter, is simply threaded into the air relief port of the cylinder head. It prevents foreign matter from being drawn into the cylinder on the return stroke of the piston, and also acts as a snubber. The snubbing reduces the piston speed and impact at the end of the stroke in both directions.

### Breather Vents Ordering Data

Breather Vent for 1/4" Pipe Tap  
(Fits cylinder sizes 4, 6, 9)  
Part No. 661-000-001

Breather Vent for 3/8" Pipe Tap  
(Fits cylinder sizes 12, 16, 24, 30, 36)  
Part No. 661-000-002

### Universal Mount

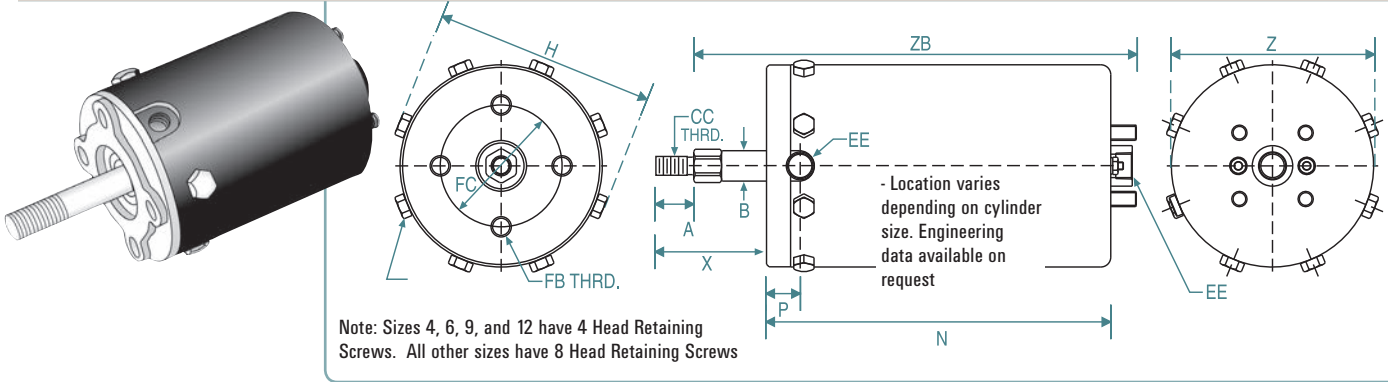

### Cap Flange Mount

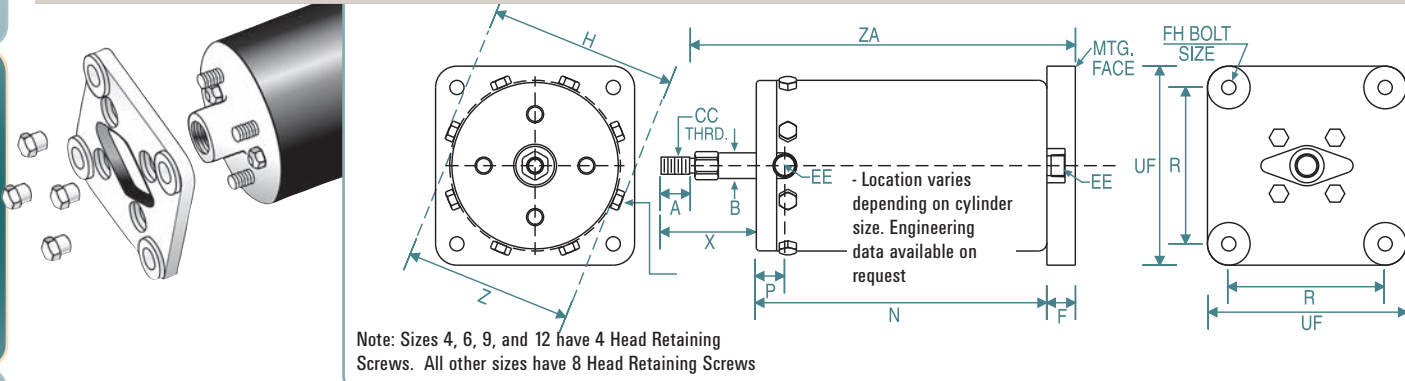

### Clevis Bracket Mount (or Stud)

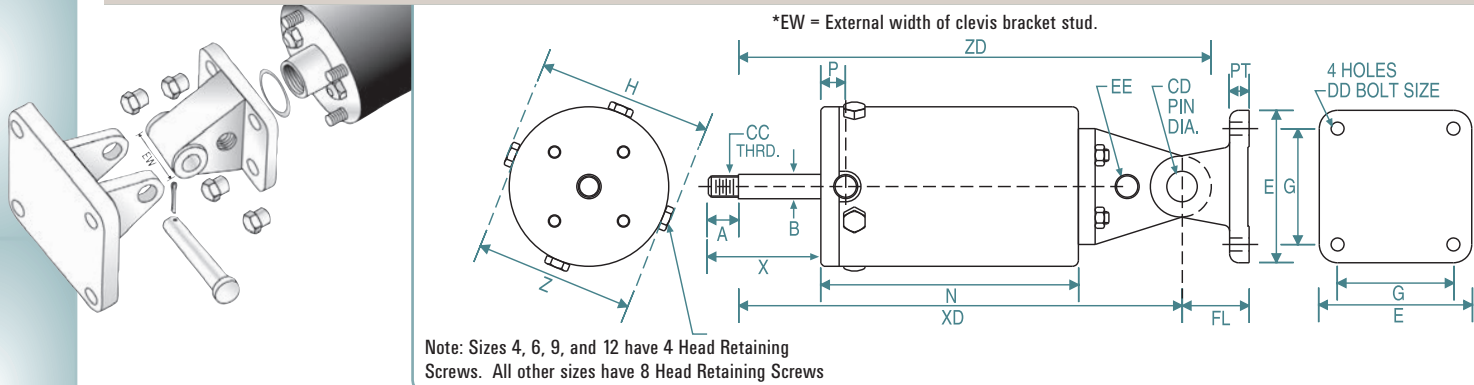

### Head Flange Mount

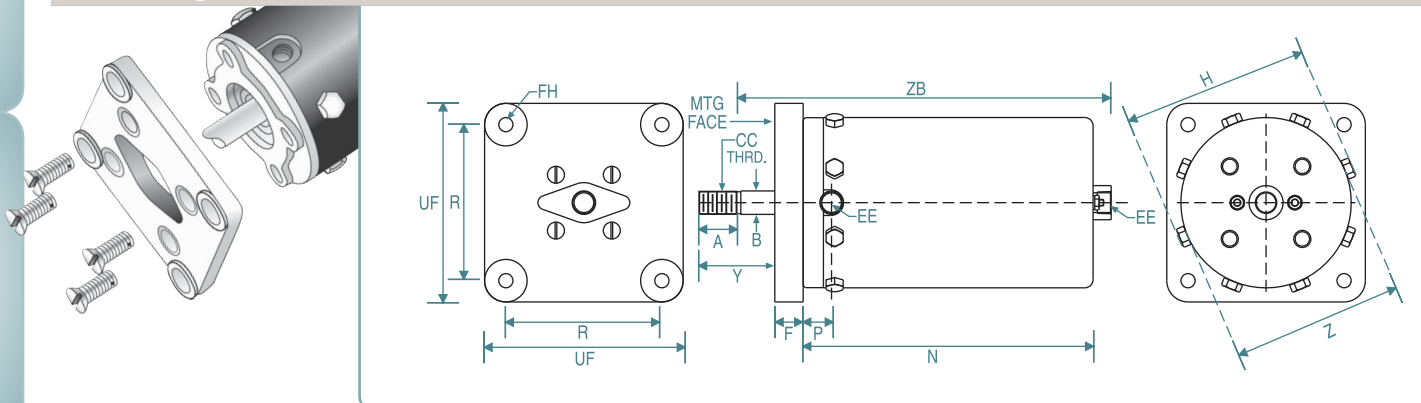

**Standard Cylinders - Universal, Cap Flange, Clevis Bracket, Head Flange Mounts — Dimensions - Inches**

Size	Series	Z	H	N	EE	FC	FB	B	P	F	R	UF	FH	CD	DD	E	FL	EW	PT	G
4	F	2.71	3.02	4.34	1/4 NPT	2.00	1/4 - 20	1/2	.50	.781	2.81	3.62	1/4	.625	1/4	3.12	1.38	.93	3/8	2.38
6	F	3.27	3.58	5.28	1/4 NPT	2.00	1/4 - 20	1/2	.51	.781	2.81	3.62	1/4	.625	1/4	3.12	1.38	.93	1/2	2.38
9	E	3.84	4.25	5.31	1/4 NPT	3.00	7/16-14	3/4	.75	.690	4.38	5.50	7/16	.750	1/4	3.75	1.69	.99	1/2	3.0
	F			6.34																
12	E	4.38	4.79	5.31	3/8 NPT	3.00	7/16-14	3/4	.75	.690	4.38	5.50	7/16	.750	1/2	4.00	1.75	1.24	1/2	3.0
	F			7.28																
16	E	4.99	5.40	6.03	3/8 NPT	3.00	1/2-13	3/4	.87	.690	4.38	5.50	1/2	.750	1/2	4.00	1.75	1.24	1/2	3.0
	F			8.38																
24	E	6.16	6.57	6.28	3/8 NPT	4.75	5/8-11	3/4	1.00	.656	6.00	7.50	1/2	1.00	1/2	5.12	2.00	1.49	5/8	4.0
	F			10.22																
30	E	6.88	7.29	7.00	3/8 NPT	4.75	5/8-11	1	1.00	.656	6.00	7.50	1/2	1.00	1/2	5.12	2.00	1.49	5/8	4.0
	F			11.44																
36	E	7.38	7.79	7.69	3/8 NPT	4.75	5/8-11	1	1.00	.656	6.00	7.50	1/2	1.00	1/2	5.12	2.00	1.49	5/8	4.0
	F			11.47																

Size	Series	BP Rod End*								SM Rod End†					
		X	Y	A	ZA	ZD	XD	ZB	CC	A	ZA	ZD	XD	ZB	CC
4	F	2.73	1.95	.75	7.10	9.07	8.45	6.72	3/8-24	1.00	6.85	8.82	8.19	6.47	7/16-20
6	F	2.69	1.91	.75	8.00	9.97	9.35	7.63	3/8-24	1.00	7.75	9.72	9.09	7.38	7/16-20
9	E	2.92	2.23	1.00	7.92	10.73	9.98	7.63	1/2-20	1.12	7.80	10.61	9.86	7.56	3/4-16
	F	2.69	2.00		8.72	11.55	10.80	8.44			8.60	11.42	10.67	8.32	
12	E	2.92	2.23	1.00	7.92	10.98	10.23	7.78	1/2-20	1.12	7.80	10.86	10.11	7.66	3/4-16
	F	2.95	2.26		9.91	12.98	12.23	9.78			9.80	12.86	12.11	9.66	
16	E	3.06	2.37	1.00	8.18	11.84	11.09	8.64	1/2-20	1.12	8.66	11.72	10.97	8.52	3/4-16
	F	2.78	2.09		10.85	13.91	13.16	10.71			10.73	13.78	13.03	10.59	
24	E	2.86	2.17	1.00	8.53	11.78	10.78	8.73	1/2-20	1.12	8.71	12.16	11.16	8.59	3/4-16
	F	2.44	1.78		12.35	16.22	15.22	12.08			12.23	15.68	14.68	12.03	
30	E	2.83	2.14	1.25	9.27	12.70	11.70	9.26	5/8-18	1.50	8.02	12.89	11.89	9.30	1-14
	F	3.05	2.36	1.50	13.68	17.11	16.11	13.53	1-12		13.68	17.11	16.11	13.53	
36	E	2.83	2.14	1.25	9.96	13.31	12.31	9.82	5/8-18	1.50	9.71	13.60	12.60	10.00	1-14
	F	3.05	2.36	1.50	13.71	17.13	16.13	13.54	1-12		13.71	17.13	16.13	13.54	



\*BP Rod End - Bellofram Products Co. Standard  
 †SM Rod End - National Fluid Power Assoc. Standards

Air Cylinders

**Standard Cylinders - Universal, Cap Flange, Clevis Bracket, Head Flange Mounts — Dimensions - Millimeters**

Size	Series	Z	H	N	FC	B	P	F	R	UF	FH	CD	DD	E	FL	EW	PT	G
4	F	68.83	76.71	110.24	50.80	12.70	12.70	19.84	71.37	91.95	6.35	15.88	6.25	79.25	35.05	23.62	9.53	60.45
6	F	83.06	90.93	134.11	50.80	12.70	12.95	19.84	71.37	91.95	6.35	15.88	6.25	79.25	35.05	23.62	12.70	60.45
9	E	97.52	107.95	134.87	76.20	19.05	19.05	17.53	111.25	139.70	11.11	19.50	6.25	95.25	42.93	25.15	12.70	76.20
	F			161.04														
12	E	112.5	121.67	134.87	76.20	19.05	19.05	17.53	111.25	139.70	11.11	19.50	12.70	101.60	44.45	31.50	12.70	76.20
	F			184.91														
16	E	126.75	137.16	153.16	76.20	19.50	22.10	17.53	111.25	139.70	12.70	19.50	12.70	101.60	44.45	31.50	12.70	76.20
	F			212.85														
24	E	156.46	166.88	159.51	120.65	19.50	25.40	16.66	152.40	190.50	12.70	25.40	12.70	130.05	50.80	37.85	15.88	101.60
	F			259.59														
30	E	174.75	185.17	177.80	120.65	25.40	25.40	16.66	152.40	190.50	12.70	25.40	12.70	130.05	50.80	37.85	15.88	101.60
	F			290.58														
36	E	187.45	197.87	195.33	120.65	25.40	25.40	16.66	152.40	190.50	12.70	25.40	12.70	130.05	50.80	37.85	15.88	101.60
	F			291.34														

Size	Series	BP Rod End*								SM Rod End†				
		X	Y	A	ZA	ZD	XD	ZB	A	ZA	ZD	XD	ZB	
4	F	69.34	49.53	19.05	180.34	230.38	244.63	170.69	25.40	173.99	224.03	208.03	164.34	
6	F	68.33	48.51	19.05	203.20	253.24	237.49	193.80	25.40	196.85	246.89	230.89	187.45	
9	E	74.17	56.64	25.40	201.17	272.54	253.49	193.80	28.45	198.12	269.49	250.44	192.02	
	F	68.33	50.80		221.49	293.37	274.32	214.38		218.44	290.07	271.02	211.33	
12	E	74.17	56.64	25.40	201.17	278.89	259.84	197.61	28.45	198.12	275.84	256.79	194.56	
	F	74.93	57.40		251.97	329.69	310.64	257.41		248.92	326.64	307.59	245.36	
16	E	77.72	60.20	25.40	207.77	300.74	281.69	219.46	28.45	219.93	279.69	278.64	216.41	
	F	70.61	53.09		275.59	353.31	334.26	272.03		272.54	350.01	330.96	268.99	
24	E	72.64	55.12	25.40	216.66	299.21	273.81	221.74	28.45	221.23	308.86	283.46	218.19	
	F	61.98	45.21		313.69	411.99	286.59	306.83		310.64	398.27	372.87	305.56	
30	E	71.88	54.36	31.75	235.46	322.58	297.18	235.20	38.10	203.71	327.41	302.00	236.22	
	F	77.47	59.94	38.10	347.47	434.59	409.19	343.66		347.47	434.59	409.19	343.66	
36	E	71.88	54.36	31.75	252.98	338.07	312.67	249.43	38.10	246.63	345.44	320.04	254.00	
	F	77.47	59.94	38.10	248.23	435.10	409.70	343.92		248.23	435.10	409.70	343.92	

\*BP Rod End - Bellofram Products Co. Standard  
 †SM Rod End - National Fluid Power Assoc. Standards



### Foot Mount

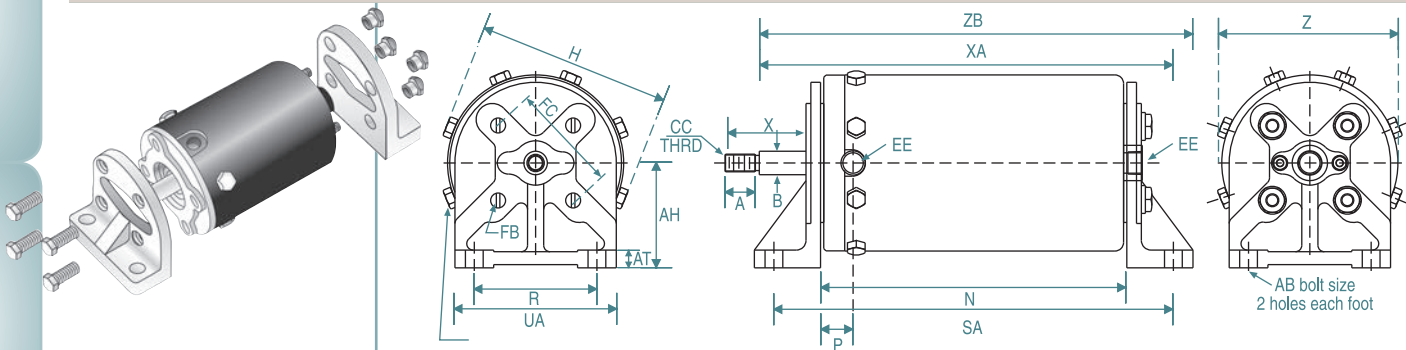

Note: Sizes 4, 6, 9, and 12 have 4 Head Retaining Screws. All other sizes have 8 Head Retaining Screws

### Standard Cylinders with Foot Mount Dimensions - Inches

Size	Series	Z	H	N	EE	FC	FB	B	P	AT	AH	UA	R	SA	AB	X	BP Rod End*				SM Rod End†			
																	A	XA	ZB	CC	A	XA	ZB	CC
4	F	2.71	3.02	4.34	1/4 NPT	2.00	1/4 - 20	1/2	.50	.38	1.88	2.62	2.00	6.59	1/4	2.41	.75	7.44	7.82	3/8-24	1.00	7.19	7.57	7/16-20
6	F	3.27	3.58	5.28	1/4 NPT	2.00	1/4 - 20	1/2	.51	.38	1.88	2.62	2.00	7.53	1/4	2.38	.75	8.35	8.72	3/8-24	1.00	8.10	8.47	7/16-20
9	E	3.84	4.25	5.31	1/4 NPT	3.00	7/16-14	3/4	.75	.56	2.75	4.00	3.00	8.56	1/2	2.24	1.00	8.86	9.55	1/2-20	1.12	8.74	9.43	3/4-16
	F			6.34										9.59				10.29	9.55			10.16		
12	E	4.38	4.79	5.31	3/8 NPT	3.00	7/16-14	3/4	.75	.56	2.75	4.00	3.00	8.56	1/2	2.30	1.00	8.86	9.56	1/2-20	1.12	8.73	9.44	3/4-16
	F			7.28										10.53				11.56	10.73			11.36		
16	E	4.99	5.40	6.03	3/8 NPT	3.00	1/2-13	3/4	.87	.56	2.75	4.00	3.00	9.28	1/2	2.31	1.00	9.72	10.42	1/2-20	1.12	9.59	10.22	3/4-16
	F			8.38										11.62				12.41	11.66			12.28		
24	E	6.16	6.57	6.28	3/8 NPT	4.75	5/8-11	3/4	1.00	.68	4.00	6.25	4.75	10.16	5/8	2.23	1.00	10.09	10.86	1/2-20	1.12	9.94	10.63	3/4-16
	F			10.22										14.09				14.29	13.10			13.79		
30	E	6.88	7.29	7.00	3/8 NPT	4.75	5/8-11	1	1.00	.68	4.00	6.25	4.75	10.88	5/8	2.20	1.25	10.52	11.20	5/8-18	1.50	10.26	10.95	1-14
	F			11.44										15.31				1-12	14.92			15.61		
36	E	7.38	7.79	7.69	3/8 NPT	4.75	5/8-11	1	1.00	.68	4.00	6.25	4.75	11.56	5/8	2.20	1.25	11.22	11.91	5/8-18	1.50	10.97	11.66	1-14
	F			11.47										15.34				1-12	14.94			15.62		

### Standard Cylinders with Foot Mount Dimensions - Millimeters

Size	Series	Z	H	N	FC	B	P	AT	AH	UA	R	SA	AB	X	BP Rod End*				SM Rod End†		
															A	XA	ZB	CC	A	XA	ZB
4	F	68.83	76.71	110.24	50.80	12.70	12.70	9.65	47.75	66.65	50.80	167.39	6.35	61.21	19.05	188.98	198.63	25.40	182.63	192.28	
6	F	83.06	90.93	134.11	50.80	12.70	12.95	9.65	47.75	66.55	50.80	191.26	6.35	60.45	19.05	212.09	221.49	25.40	205.74	215.14	
9	E	97.54	107.95	134.87	76.20	19.05	19.05	14.22	69.85	101.60	76.20	273.41	12.70	56.90	25.40	225.04	242.57	261.37	28.45	222.00	239.52
	F			161.04																	
12	E	111.25	121.67	134.87	76.20	19.05	19.05	14.22	69.85	101.60	76.20	273.41	12.70	58.42	25.40	225.04	242.82	293.62	28.45	221.74	239.78
	F			184.91																	
16	E	126.75	137.16	153.16	76.20	19.05	22.10	14.22	69.85	101.60	76.20	235.71	12.70	58.67	25.40	246.89	264.67	315.21	28.45	243.59	259.59
	F			212.85																	
24	E	156.46	166.88	159.51	120.65	19.05	25.40	17.27	101.60	158.75	120.65	258.06	15.88	56.64	25.40	256.29	275.84	331.72	28.45	252.48	270.00
	F			259.59																	
30	E	174.75	185.17	177.80	120.65	25.40	25.40	17.27	101.60	158.75	120.65	276.35	15.88	55.88	31.75	267.21	284.48	378.97	38.10	260.60	278.13
	F			290.58																	
36	E	187.45	197.8	195.33	120.65	25.40	25.40	17.27	101.60	158.75	120.65	293.62	15.88	55.88	31.75	284.99	302.51	379.48	38.10	278.64	296.16
	F			291.34																	

### Universal Mount

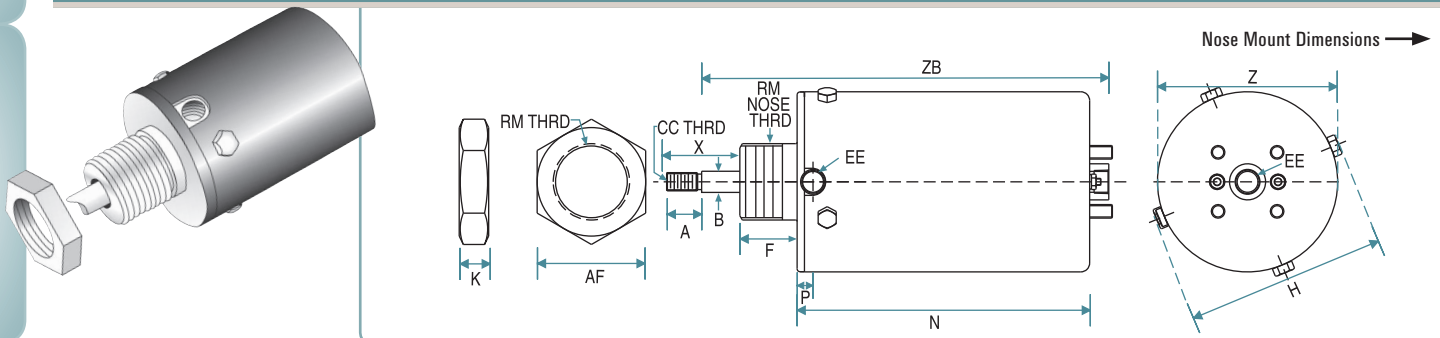



**Super Cylinder**

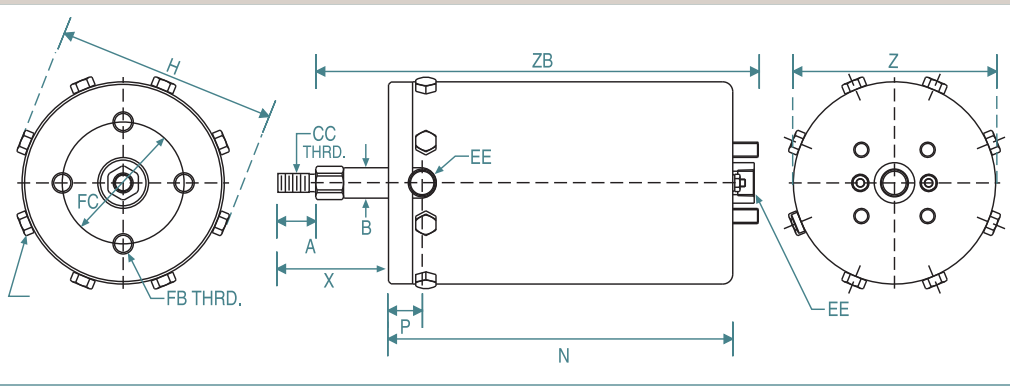

**Standard Cylinders with Foot Mount Dimensions - Inches**

Size	Series	Z	H	N	EE	FC	FB	B	P	X	BP Rod End*			SM Rod End†		
											A	ZB	CC	A	ZB	CC
4	F	2.71	3.02	4.34	1/4 NPT	2.00	1/4 - 20	1/2	.50	3.10	.75	7.09	3/8-24	1.00	6.85	7/16-20
6	F	3.27	3.58	5.28	1/4 NPT	2.00	1/4 - 20	1/2	.51	2.16	.75	7.09	3/8-24	1.00	6.85	7/16-20
9	F	3.84	4.25	6.34	1/4 NPT	3.00	7/16-14	3/4	.75	3.50	1.00	9.25	1/2-20	1.12	9.13	3/4-16
12	F	4.38	4.79	7.28	3/8 NPT	3.00	7/16-14	3/4	.75	2.57	1.00	9.38	1/2-20	1.12	9.26	3/4-16
16	F	4.99	5.40	8.38	3/8 NPT	3.00	1/2-13	3/4	.87	3.78	1.00	11.69	1/2-20	1.12	11.57	3/4-16
24	F	6.16	6.57	10.22	3/8 NPT	4.75	5/8-11	3/4	1.00	2.00	1.00	11.75	1/2-20	1.12	11.75	3/4-16
30	F	6.88	7.29	11.44	3/8 NPT	4.75	5/8-11	1	1.00	3.05	1.50	13.52	1-12	1.50	13.52	1-14
36	F	7.38	7.79	11.47	3/8 NPT	4.75	5/8-11	1	1.00	3.05	1.50	13.55	1-12	1.50	13.55	1-14

**Standard Cylinders with Foot Mount Dimensions - Millimeters**

Size	Series	Z	H	N	FC	B	P	X	BP Rod End*		SM Rod End†	
									A	ZB	A	ZB
4	F	68.83	76.71	110.24	50.80	12.70	12.70	78.74	19.05	180.09	25.40	173.99
6	F	83.06	90.93	134.11	50.80	12.70	12.95	54.86	19.05	180.09	25.40	173.99
9	F	97.54	107.95	161.04	76.20	19.05	19.05	88.90	25.40	234.95	28.45	231.90
12	F	111.25	121.67	184.91	76.20	19.05	19.05	65.28	25.40	238.25	28.45	235.20
16	F	126.75	137.16	212.85	76.20	19.05	22.10	96.01	25.40	296.93	28.45	293.88
24	F	156.46	166.88	259.59	120.65	19.05	25.40	50.80	25.40	298.45	28.45	298.45
30	F	174.75	185.17	290.58	120.65	25.40	25.40	77.47	38.10	343.41	38.10	343.41
36	F	187.45	197.80	195.33	120.65	25.40	25.40	77.47	38.10	344.17	38.10	344.17

**Super Cylinders are equipped with linear ball bearings and hardened steel rods.**

**Nose Mount Dimensions - Inches**

Size	Series	Z	H	N	EE	F	RM	B	X	BP Rod End*			SM Rod End†			AF	K	P
										A	ZB	CC	A	ZB	CC			
4	F	2.71	3.02	4.34	1/4 NPT	1.25	1-3/8 - 12	1/2	1.48	.75	6.72	3/8 - 24	1.00	6.47	7/16 - 20	2.06	.78	.59
6	F	3.27	3.58	5.28	1/4 NPT	1.25	1-3/8 - 12	1/2	1.44	.75	7.63	3/8 - 24	1.00	7.06	7/16 - 20	2.06	.78	.59
9	E	3.84	4.15	5.16	1/4 NPT	1.25	1-5/8 - 12	3/4	1.83	1.00	7.65	1/2 - 20	1.12	7.53	3/4-16	2.44	.91	.59
	F			6.19					1.61		8.45			8.33				

**Nose Mount Dimensions - Millimeters**

Size	Series	Z	H	N	F	B	X	BP Rod End*		SM Rod End†		AF	K	P
								A	ZB	A	ZB			
4	F	68.83	76.71	110.24	31.75	12.70	37.59	19.05	170.69	25.40	164.34	52.32	19.81	14.99
6	F	83.06	91.93	134.11	31.75	12.70	36.58	19.05	193.80	25.40	179.32	52.32	19.81	14.99
9	E	97.54	105.41	131.06	31.75	19.05	46.48	25.40	194.31	28.45	191.26	61.98	23.11	14.99
	F			157.23			40.89		214.63		211.58			

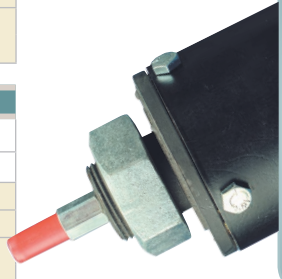

### Small Bore Cylinder

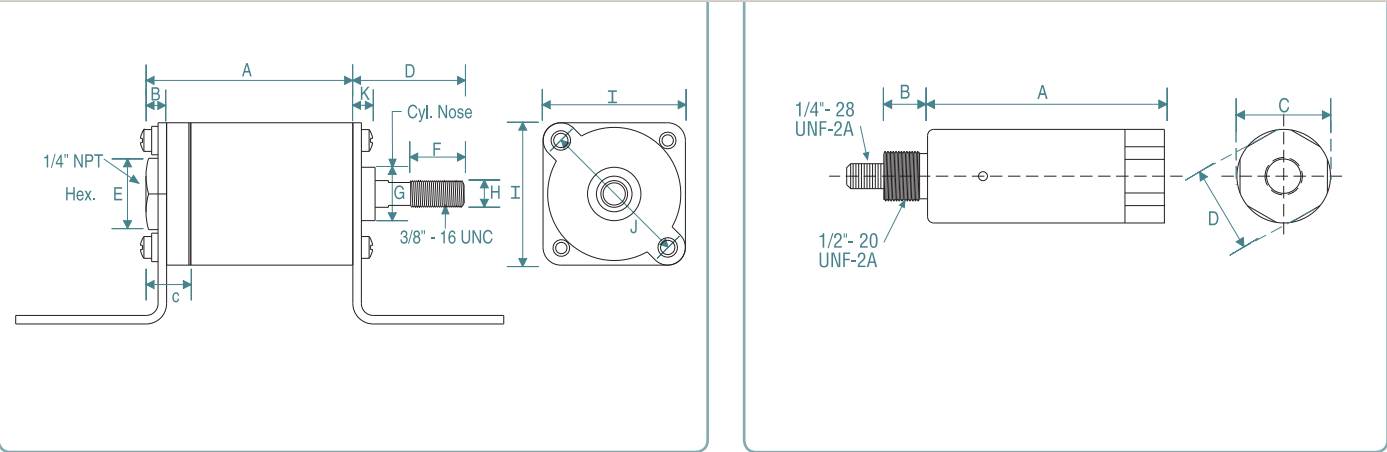

### Small Bore Cylinder Dimensions - Inches

Part Number	A	B	C	D	E	F	G	H	I	J	K	Part Number	A	B	C	D
980-008-000	2-29/32	13/64	5/8	19/16	13/16	3/4	3/4	3/8	2	2-1/8	5/16	980-013-000	2.81	0.438	15/16	7/8
980-077-000	3-21/32	13/64	5/8	19/16	13/16	3/4	3/4	3/8	2	2-1/8	5/16	980-034-000	1.95	0.244	15/16	7/8
												980-014-000				
												980-035-000				

### Small Bore Cylinder Dimensions - Millimeters

Part Number	A	B	C	D	E	F	G	H	I	J	K	Part Number	A	B	C	D
980-008-000	73.8	5.2	15.9	39.6	20.6	19.1	19.1	9.5	50.8	54.0	7.9	980-013-000	71.4	11.1	23.8	22.2
980-077-000	92.9	5.2	15.9	39.6	20.6	19.1	19.1	9.5	50.8	54.0	7.9	980-034-000	49.5	6.2	23.8	22.2
												980-014-000				
												980-035-000				

### Rod Clevis and Jam Nut

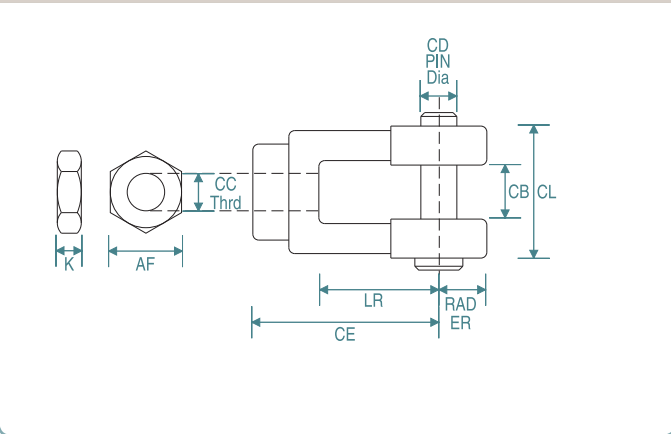

### Rod Clevis and Jam Nut Ordering Information

Ordering Code	Description
	<b>Size</b>
<b>04</b>	Area in Square Inches: 04, 06, 09, 16, 24, 30, or 36
	<b>Series</b>
<b>E</b>	Determines Stroke: Make a selection from Operating Data Table on pg. 47
<b>F</b>	
	<b>Rod</b>
<b>BP</b>	Bellofram Product Standard
<b>SM</b>	National Fluid Power Assoc. Standard
	Make a selection from dimensional data table on pgs. 51-54
	<b>Rod Clevis</b>
<b>RC</b>	Rod Clevis

Example: 36-F-BP-RC is a Rod Clevis for a size 36 sq. in. cylinder with a 1-12 rod thread.

### Rod Clevis and Jam Nut Dimensions - Inches

Size	Rod End	Rod End CC Thrd.	Series	CB	CD Pin Dia.	CE	CL	Rad. ER	LR	AF	K
4	BP	3/8-24	F	.56	3/8	1-7/8	1.38	.53	1.25	9/16	7/32
	SM	7/16-20			7/16					11/16	1/4
6	BP	3/8-24	F	.56	3/8	1-7/8	1.38	.53	1.25	9/16	7/32
	SM	7/16-20			7/16					11/16	1/4
9	BP	1/2-20	E or F	.56	1/2	1-7/8	1.38	.53	1.25	3/4	5/16
	SM	3/4-16		.88	3/4	2-3/8	2.12	.75		1-1/8	27/64
12	BP	1/2-20	E or F	.56	1/2	1-7/8	1.38	.53	1.25	3/4	5/16
	SM	3/4-16		.88	3/4	2-3/8	2.12	.75		1-1/8	27/64
16	BP	1/2-20	E or F	.56	1/2	1-7/8	1.38	.53	1.25	3/4	5/16
	SM	3/4-16		.88	3/4	2-3/8	2.12	.75		1-1/8	27/64
24	BP	1/2-20	E or F	.56	1/2	1-7/8	1.38	.53	1.25	3/4	5/16
	SM	3/4-16		.88	3/4	2-3/8	2.12	.75		1-1/8	27/64
30 and 36	BP	5/8-18	E	.56	9/16	1-7/8	1.38	.53	1.25	1-15/16	3/8
	BP	1-12	F	1.50	1	3-1/2	3.50	1.00	1.50	1-1/2	35/64
	SM	3/4-16									
SM	1-14	E or F	1.50	1	3-1/2	3.50	1.00	1.50	1-1/2	35/64	

BP Rod End – Bellofram Products Co. Standard, SM Rod End – National Fluid Power Assoc. Standards



### Cylinder Cap End Mounting Studs

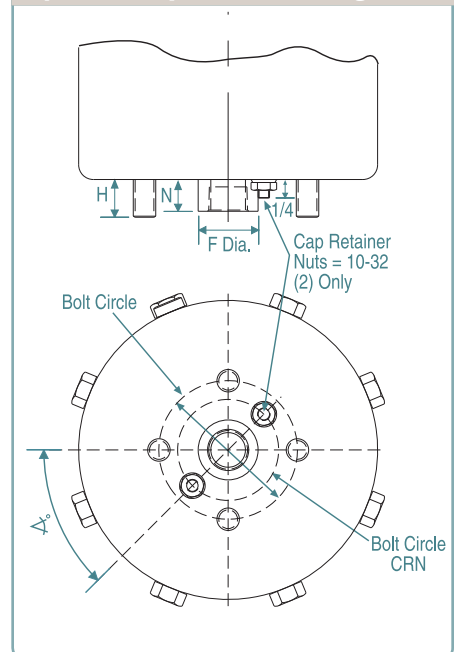

### Rod Clevis and Jam Nut Dimensions - Millimeters

Size	Rod End	Series	CB	CD Pin Dia.	CE	CL	Rad. ER	LR	AF	K
4	BP	F	14.22	9.53	47.63	35.05	13.46	31.75	14.29	5.56
	SM			11.11					17.46	6.36
6	BP	F	14.22	9.53	47.63	35.05	13.56	31.75	14.29	5.56
	SM			11.11					17.46	6.35
9	BP	E or F	14.22	12.70	47.63	35.05	13.56	31.75	19.05	7.94
	SM		22.35	19.05	60.33	53.85	19.05		18.58	10.72
12	BP	E or F	14.22	12.70	47.63	35.05	13.56	31.75	19.05	7.94
	SM		22.35	19.05	60.33	53.85	19.05		28.58	10.72
16	BP	E or F	14.22	12.70	47.63	35.05	13.56	31.75	19.05	7.94
	SM		22.35	19.05	60.33	53.85	19.05		28.59	10.72
24	BP	E or F	14.22	12.70	47.63	35.05	13.56	31.75	19.05	7.94
	SM		22.35	19.05	60.33	53.85	19.05		28.59	13.89
30 and 36	BP	E	14.22	14.29	47.63	35.05	13.46	31.75	33.34	9.53
	BP	F	38.1	25.4	88.90	88.90	25.4	38.1	38.1	13.89
	SM									
SM	E or F	38.1	25.4	88.90	88.90	25.4	38.1	38.1	13.89	

### Cylinder Cap End Mounting Studs Dimensions - Inches

Size	Number of Studs	Size of Stud	H (Approx.)	Bolt Circle	F (Boss)	N	Bolt Circle CRN	<°
4	2	1/4-20	5/8	1-5/16	11/16	13/32	1-3/8	90
6	2	1/4-20	5/8	1-1/2	11/16	13/32	1-3/8	90
9	4	1/4-20	5/8	2	11/16	13/32	1-3/8	45
12	4	1/4-20	5/8	2-5/16	1	17/32	1-11/16	45
16	4	3/8-16	5/8	2-5/16	1	17/32	1-11/16	45
24	4	3/8-16	9/16	3-1/8	1	17/32	1-11/16	45
30	4	1/2-13	11/16	4	1	17/32	1-11/16	45
36	4	1/2-13	11/16	4	1	17/32	1-11/16	45

**All Diaphragm Cylinders feature Bellofram Rolling Diaphragms for low friction and increased sensitivity!**

## Diaphragm Cylinders Part Numbers

### Type S (Spring Return)

Series		E				F			
Rod		BP		SM		BP		SM	
Mount		UM	N	ZB	N	UM	N	UM	N
Size (sq. in.)	4					900-002-000	900-006-000	900-004-000	900-008-000
	6					900-010-000	900-014-000	900-012-000	900-016-000
	9	900-018-000	900-022-000	900-020-000	900-024-000	900-026-000	900-030-000	900-028-000	900-032-000
	12	900-034-000		900-036-000		900-038-000		900-040-000	
	16	900-042-000		900-044-000		900-046-000		900-048-000	
	24	900-050-000		900-052-000		900-054-000		900-056-000	
	30	900-058-000		900-060-000		900-062-000		900-064-000	
	36	900-066-000		900-068-000		900-070-000		900-072-000	

All cylinders are supplied with cap mounting studs. Consult factory for cylinders required without cap mounting studs. Select part numbers from non-shaded areas only.

### Type D Cylinders (Double Acting)

Series		E		F			
Rod		BP	SM	BP		SM	
Mount		UM	UM	UM	N	UM	N
Size (sq. in.)	4			902-002-000	902-006-000	902-004-000	902-008-000
	6			902-010-000	902-014-000	902-012-000	902-016-000
	9			902-018-000	902-022-000	902-020-000	902-024-000
	12	902-026-000	902-028-000	902-030-000		902-032-000	
	16	902-034-000	902-036-000	902-038-000		902-040-000	
	24	902-042-000	902-044-000	902-046-000		902-048-000	
	30	902-050-000	902-052-000	902-054-000		902-056-000	
	36	902-058-000	902-060-000	902-062-000		902-064-000	

All cylinders are supplied with cap mounting studs. Consult factory for cylinders required without cap mounting studs. Select part numbers from non-shaded areas only.

### Type SS (Super Cylinders)

Series		F	
Rod		BP	SM
Mount		UM	UM
Size (sq. in.)	4	903-074-000	903-001-000
	6	903-076-000	903-011-000
	9	903-078-000	903-021-000
	12	903-080-000	903-031-000
	16	903-082-000	903-041-000
	24	903-084-000	903-051-000
	30	903-086-000	903-061-000
	36	903-088-000	903-071-000

### Repair Kits

Spring Return Cylinders				Double Acting Cylinders				Super Cylinders	
Diaphragm Kits		Bearing Kits		Diaphragm Kits		Bearing Kits		Bearing Kits	
Kit No.	Part No.	Kit No.	Part No.	Kit No.	Part No.	Kit No.	Part No.	Kit No.	Part No.
S4FN	970-041-000	SB46S	970-058-000	D4S	970-014-000	DB46S	970-064-000	SSB46S	970-134-000
S6FN	970-042-000	SB924S	970-060-000	D6S	970-018-000	DB924S	970-066-000	SSB924S	970-133-000
S9EN	970-043-000	SB36FB	970-062-000	D9S	970-020-000	DB36FB	970-068-000	SSB36FB	970-135-000
S9FN	970-044-000			D12ES	970-022-000				
S12E	970-045-000			D12FS	970-024-000				
S12F	970-046-000			D16ES	970-026-000				
S16E	970-047-000			D16FS	970-028-000				
S16F	970-048-000			D24ES	970-030-000				
S24E	970-049-000			D24FS	970-032-000				
S24F	970-050-000			D30ES	970-034-000				
S30E	970-051-000			D30FS	970-036-000				
S30F	970-052-000			D36ES	970-038-000				
S36E	970-053-000			D36FS	970-040-000				
S36F	970-054-000								

### Mounting Kits

Size	FM	CFM	HFM	CBM	CBS
4	904-001-000	904-012-000	904-008-000	904-026-000	904-019-000
6	904-002-000	904-013-000	904-008-000	904-027-000	904-020-000
9	904-003-000	904-014-000	904-009-000	904-028-000	904-021-000
12	904-004-000	904-015-000	904-009-000	904-029-000	904-022-000
16	904-005-000	904-016-000	904-010-000	904-030-000	904-023-000
24	904-006-000	904-017-000	904-010-000	904-031-000	904-024-000
30	904-007-000	904-018-000	904-011-000	904-032-000	904-025-000
36	904-007-000	904-018-000	904-011-000	904-032-000	904-025-000

### Rod Clevis Mounts

Rod		BP	SM
Size (sq. in.)	4	904-033-000	904-037-000
	6	904-033-000	904-037-000
	9	904-034-000	904-038-000
	12	904-034-000	904-038-000
	16	904-034-000	904-038-000
	24	904-034-000	904-038-000
	30 and 36 (E stroke)		904-039-000
	30 and 36 (F stroke)	904-036-000	904-039-000