

Introduction

As an industry leader in motor control, Benshaw is known for their offering of standard and custom engineered drive packages. If an off-the-shelf unit does not meet your needs, our dedicated team can design the drive solution you need.

Benshaw now offers a complete range of low voltage variable speed drive solutions ... from multi-purpose micro drives and high performance industrial drives to IEEE 519 clean power drives, NEMA 4X washdown duty drives and custom configured packaged drive solutions.

Benshaw GM2 Series is a sensorless vector, variable frequency drive. This micro-drive may be small...but don't let looks fool you. The GM2 Series offers enhanced performance and reliable operation in a robust, yet compact, user-friendly design. Powerful, yet small...it is the ideal choice for cost sensitive OEM or end user requirements. And it is the ideal drive for Benshaw distributors to keep in stock because of its versatility.

The **Benshaw S Series** is a compact yet powerful AC drive designed for the most demanding applications. Available in 'normal duty' ratings up to 15HP and 'heavy duty' ratings up to 10HP, the S Series puts you in control. Whether your application calls for V/Hz control, Sensorless Vector Control or Torque Control, the S Series has you covered. Modbus RTU is standard with optional communication protocols available.

The **Benshaw SW Series** NEMA 4X Washdown Drives are heavy duty rated for applications from 0.5-30HP. Designed for high pressure washdown, all SW Series drives feature a rugged UL Type 4X (IP66) indoor rated polycarbonate enclosure that exceeds NEMA 1, 12, 4 and 4X standards. A convenient built-in power disconnect switch, 4 digit, 7-segment display and an optional remote LCD Display/Keypad with a Quick Start menu, make it easy to program and control.

The **Benshaw H2 Series** sets the new standard for variable frequency drives. It can be used as a general purpose industrial drive with V/hz or Vector control (with ratings for normal or heavy duty applications from 5-800HP). For fan and pumps applications, simply use the built-in macros designed to meet the basic requirements of the water/wastewater, irrigation and HVAC industries. Built in communication protocols include Modbus-RTU, BACnet and Metasys-N2.



GM2 SERIES - GENERAL PURPOSE MICRO DRIVE

The Benschaw GM2 Series is a sensorless vector, variable frequency drive. This micro-drive may be small...but don't let looks fool you. The GM2 Series offers enhanced performance and reliable operation in a robust, yet compact, user-friendly design. Powerful, yet small...it is the ideal choice for cost sensitive OEM or end user requirements. And it is the ideal drive for Benschaw distributors to keep in stock because of its versatility. The GM2 Series is easy to install, simple to program and offers dual ratings for both normal and heavy duty applications.

STANDARD FEATURES - HARDWARE

- Dual Rated - Normal and Heavy Duty
- 240V: 1HP~15 HP (ND), 0.5 HP~10HP (HD)
- 480V: 1HP~15 HP (ND), 0.5 HP~10 HP (HD)
- Display - 4 digit, 7 Segment with 4 LED Indicators
- Protected Chassis - UL Open (IP20)
- DIN Rail mounting (up to 7.5 HP, 5.5 kW)
- EMC Filter (480V only)
- Internal Brake IGBT
- Single Phase Input (derating required)
- Built in Potentiometer
- RJ45 Port (Modbus-RTU) or Remote 7-Segment Display/Keypad

STANDARD FEATURES - SOFTWARE

- Modbus - RTU
- Control - V/Hz, Sensorless Vector, Slip Compensation
- Auto Tuning
- Torque Limits
- PID Control
- Regen Avoidance
- Kinetic Energy Buffering (KEB), RideThrough

COMMUNICATIONS

- Standard: Modbus-RTU
- Option: Ethernet/IP - Modbus-TCP
- WinDRIVE:** PC Based Software for Commissioning and Monitoring



Feature	Benefit
Robust Design	Construction of the air flow design minimizes exposure of critical components (IGBT, PCB, etc.) to outside contaminants
Built-in EMC Filter	Embedded C3 EMC filter to meet EN618000-3 standards and provide noise reduction
V/F Acceleration and Deceleration Function	<ul style="list-style-type: none"> • Auto torque boost (ATB) enhancing acceleration performance in V/F mode • Flux braking enhancing deceleration performance in V/F mode
Sensorless Vector Control	Performs enhanced high torque at low speed with sensorless vector control
KEB Operation (Kinetic Energy Buffering)	DC link voltage is maintained during power loss or brownout by using regenerative energy from the motor
Flying Start	Select optimal flying start operation for different applications
Fan Life-cycle Diagnosis	Keypad displays a replacement warning at 50,000 hours of fan operating time or user setting level of fan replacement
Material Design	Enhanced thermal resistance and increased thickness to prevent damage

GM2 SERIES - PRICING

240V - Open Chassis	Normal Duty 120% OL / 1 min.		Heavy Duty 150% OL / 1min.		Dimensions (inches)				
	HP	Amps	HP	Amps	H	W	D	Weight (lbs)	List Price
VFD-RSI-001-GM2-2C	1.0	3.1	0.5	2.5	6.46	3.40	5.50	2.3	\$520
VFD-RSI-002-GM2-2C	2.0	6	1.0	5	6.46	3.40	5.50	2.3	\$549
VFD-RSI-003-GM2-2C	3.0	9.6	2.0	8	6.98	3.98	6.25	3.0	\$584
VFD-RSI-005-GM2-2C	5.0	12	3.0	11	6.98	3.98	6.25	3.1	\$608
VFD-RSI-007-GM2-2C	7.5	18	5.0	17	7.60	5.31	6.25	4.2	\$741
VFD-RSI-010-GM2-2C	10	30	7.5	24	9.46	7.10	6.00	6.8	\$1,163
VFD-RSI-015-GM2-2C	15	40	10	32	9.46	7.10	6.00	7.1	\$1,315

480V - Open Chassis	Normal Duty 120% OL / 1 min.		Heavy Duty 150% OL / 1min.		Dimensions (inches)				
	HP	Amps	HP	Amps	H	W	D	Weight (lbs)	List Price
VFD-RSI-001-GM2-4C	1.0	2	0.5	1.3	6.46	3.40	5.50	2.3	\$547
VFD-RSI-002-GM2-4C	2.0	3.1	1.0	2.5	6.46	3.40	5.50	2.4	\$571
VFD-RSI-003-GM2-4C	3.0	5.1	2.0	4	6.98	3.98	6.25	3.2	\$601
VFD-RSI-005-GM2-4C	5.0	6.9	3.0	5.5	6.98	3.98	6.25	3.2	\$630
VFD-RSI-007-GM2-4C	7.5	10	5.0	9	7.60	5.31	6.25	4.4	\$713
VFD-RSI-010-GM2-4C	10	16	7.5	12	9.46	7.10	6.00	7.1	\$1,018
VFD-RSI-015-GM2-4C	15	23	10	16	9.46	7.10	6.00	7.2	\$1,087

GM2 Series - Accessories

Model Number	Description	List Price
PC-100093-00	Ethernet / IP, Modbus - TCP option, dual port	\$388
KP-100002-00	Keypad / display (7-Segment LED), remote, w / 1M cable	\$136
KP-100002-01	Keypad / display (7-Segment LED), remote, w / 2M cable	\$136
KP-100002-02	Keypad / display (7-Segment LED), remote, w / 3M cable	\$141
KP-100002-03	Keypad / display (7-Segment LED), remote, w / 5M cable	\$147
EN-101036-00	Conduit box, 1HP - 2HP, 230V / 480V	\$92
EN-101036-01	Conduit box, 3HP - 5HP, 230V / 480V	\$95
EN-101036-02	Conduit box, 7.5HP, 230V / 480V	\$101
EN-101036-03	Conduit box, 10HP - 15HP, 230V / 480V	\$113

GM2 SERIES - INPUT AND OUTPUT SPECIFICATIONS

3-Phase 240V, 1 HP - 15 HP (0.75 - 11 kW)

RSI-XXX-GM2-2C			001	002	003	005	007	010	015
240V, w/3Ø Input	Normal Duty, 120% OL	HP	1	2	3	4	7.5	10	15
		kW	0.75	1.5	2.2	4	5.5	7.5	11
		Amps	3.1	6	9.6	12	18	30	40
		KVA	1.2	2.3	3.8	4.6	6.9	11.4	15.2
	Heavy Duty, 150% OL	HP	0.5	1	2	3	5	7.5	10
		kW	0.4	0.75	1.5	2.2	4	5.5	7.5
		Amps	2.5	5	8	11	17	24	32
		KVA	1	1.9	3	4.2	6.5	9.1	12.2
240V, w/1Ø Input	Normal Duty	HP	-	0.75	1.5	2	3	5	7.5
		Amps	2	3.6	5.9	6.7	9.8	16.3	22
	Heavy Duty	HP	-	0.5	1	1.5	3	3	5
		Amps	1.5	2.8	4.6	6.1	9.3	12.8	17.4
Rated Output	Output frequency		0-400 Hz (IM Sensorless: 0 - 120 Hz)						
	Output voltage (V)		3-phase 200-240V						
	Voltage (V)		3-phase 200-240VAC (- 15% to + 10%)						
			1-phase 240VAC (- 5% to + 10%)						
	Input frequency		3-phase 50-60 Hz (± 5%)						
			1-phase 60Hz only (± 5%)						
Rated Current (A)	Normal Duty	3	6.3	10.8	13.1	19.4	32.7	44.2	
	Heavy Duty	2.2	4.9	8.4	11.8	18.5	25.8	34.9	
Weight (lb / kg)		lbs	2.3	2.3	3	3	4.2	6.8	7.1
		kg	1.04	1.06	1.36	1.4	1.89	3.08	3.21
Heat Dissipation (W)			22	45	79	117	208	281	382
Degree of Protection			UL Open Type (IP20), UL Type 1 achieved with optional conduit box						

GM2 SERIES - INPUT AND OUTPUT SPECIFICATIONS

3-Phase 480V, 1 HP - 15 HP (0.75 - 11 kW)

RSI-XXX-GM2-4C			001	002	003	005	007	010	015
480V, w/3Ø Input	Normal Duty, 120% OL	HP	1	2	3	5	7.5	10	15
		kW	0.75	1.5	2.2	4	5.5	7.5	11
		Amps	2	3.1	5.1	6.9	10	16	23
		KVA	1.5	2.4	3.9	5.3	7.6	12.2	17.5
	Heavy Duty, 150% OL	HP	0.5	1	2	3	5	7.5	10
		kW	0.4	0.75	1.5	2.2	4	5.5	7.5
		Amps	1.3	2.5	4	5.5	9	12	16
		KVA	1	1.9	3	4.2	6.5	9.1	12.2
480V, w/1Ø Input	Normal Duty	HP	0.5	0.75	1~1.5	2	3	5	7.5
		Amps	1.3	1.9	2.8	3.6	5.4	8.7	12.6
	Heavy Duty	HP	-	0.5	1	1.5	3	3	5
		Amps	0.7	1.4	2.1	2.8	4.9	6.4	8.7
Rated Output	Output frequency	0-400 Hz (IM Sensorless: 0-120 Hz)							
	Output voltage (V)	3-phase 380-480 V							
Rated Input	Voltage (V)		3-phase 380-480 VAC (- 15% to + 10%)						
			1-phase 480VAC (- 5% - + 10%)						
	Input frequency		3-phase 50-60 Hz (± 5%)						
			1-phase 60 Hz only (± 5%)						
Rated Current (A)	Normal Duty	2	3.3	5.5	7.5	10.8	17.5	25.4	
	Heavy Duty	1.1	2.4	4.2	5.9	9.8	12.9	17.5	
Weight (lb / kg)		lbs	2.3	2.4	3.2	3.2	4.4	7.1	7.2
		kg	1.04	1.08	1.44	1.46	1.98	3.24	3.28
Heat Dissipation (W)		24	42	71	99	176	231	315	
Degree of Protection		UL Open Type (IP20), UL Type 1 achieved with optional conduit box							

GM2 SERIES - PRODUCT SPECIFICATION DETAILS

Feature		Description			
Control	Control method	V/F control, Sensorless Vector, Slip Compensation			
	Frequency settings resolution	Digital command: 0.01 Hz			
		Analog command: 0.06 Hz (60 Hz standard)			
	Frequency accuracy	1% of maximum output frequency			
	V/F pattern	Linear, Square Reduction, User V/F			
	Overload capacity	Normal Duty: 120%, 1 minute			
Heavy Duty: 150%, 1 minute					
Torque boost	Manual torque boost, Automatic torque boost				
Operation	Start/Stop	Keypad, terminal strip, communication operation			
	Frequency settings	Analog type: 0-10 V, 4-20 mA, -10 +10 V (bipolar)			
		Digital type: keypad			
	Operation functions	Basic	Advanced		
		Start/Stop operation	Sensorless Vector Control		
		Start/Stop Modes	Auto Tuning		
		Frequency Reference Sources	Torque Limits		
		Auxiliary Frequency Reference	PID Control		
		Multi-Step Speeds	Slip Compensation		
		Multi-Step Accel/Decel Times	Energy Save Mode		
		2nd Source (HOA)	Regen Avoidance		
		Accel/Decel Times	VFD Fan Control		
		Accel/Decel Patterns			
		Dwell Frequency Operation	Loss of Power		
		Jog	Ride Through (KEB)		
		Auto Start	Safe Stop		
		Auto Resert/Restart	Speed Search		
			V/Hz. Control Pattern	Braking	
			Linear, Squared, User V/Hz	DC Injection Braking	
			Torque Boost	Stall Prevention	
				Power Braking	
			FWD/REV Run Prevention	Flux Braking	
		Frequency Limits	External Brake Control		
		Jump Frequencies			
		3-wire Control			
		Fire Mode			
	Input	(5) Multi-function terminals (P1 -P5)	Select PNP (Source) or NPN (Sink) mode		
			Functions of the digital inputs are set with parameters In. 65 - In. 69		
• Forward/Reverse			• Run Enable (Interlock)		
• Reset			• External trip		
• Emergency stop			• Jog operation (FWD/REV)		
• Multi-Step frequencies			• Multi-Step Acc/Dec		
• DC braking during stop			• Second motor selection		
• Frequency increase			• Up/Down Frequency		
• 3-wire			• Analog Hold (frequency)		
• Acc/Dec/Stop			• Exit PID Operation		

GM2 SERIES - PRODUCT SPECIFICATION DETAILS

Feature		Description		
Operation	Output	Programmable Output Relays		
		Relay 1 (A1-C1-B1)		
		Relay 2 (A2-C2)		
	Analog output	0-12 VDC: Programmable Analog Output		
Protection	Trip	<ul style="list-style-type: none"> Motor Overload Motor Under Load Over Current (OC1) Over Voltage Low Voltage Ground Fault Motor Over Heat (Eth) Phase Open (In/Out) Inverter Overload No Motor Trip Over Torque 		
		<ul style="list-style-type: none"> Under Torque Inverter Over Heat Short Circuit (OC2) External Trip Hardware Fault Temperature Sensor (NTC) Fan Fault Pre-PID Operation Failure External Brake Trip Reference Loss Option Board Trip 		
		Alarm	Warnings: Reference Loss, Motor Overload, Motor Under Load, Inverter Overload, Fan, Dynamic Braking Rate Warning, Auto Tuning Error, Inverter Overheat	
		Instantaneous Power Outage	Normal Duty: Less than 8ms (~1/2 cycle)	
			Heavy Duty: Less than 15ms (~1 cycle)	
			For longer outages use KEB operation and/or Auto Restart operation	
		Structure / Working Environment	Cooling type	Forced fan cooling structure
			Protection structure	UL Open Type (IP20), UL Enclosed Type 1 is achieved with conduit box installation (option)
			Ambient Operating Temperature	14°F ~ + 104°F (- 10°C ~+ 40°C)
				Derating: 2% output amps for every degree above 104°F (40°C), maximum 122°F (50°C)
				No ice or frost should be present
			Ambient humidity	Less than 95% RH (avoid condensation forming)
Storage temperature	-4°F ~ + 149°F (- 20°C ~ + 65°C)			
Environmental factors	Prevent contact with corrosive gases, flammable gases, oil stains, dust, and other pollutants (Pollution Degree 2 Environment)			
Operation /Altitude/Vibration	3280 ft (1,000 m)			
	Apply derating of 1% voltage/output current for every 100 m above 1,000 m, maximum of 4,000 m			
	Less than 9.8 m/sec ² (1G)			
Air pressure	10 ~ 15 PSI (70 ~ 106 kPa)			

GM2 SERIES - WIRING

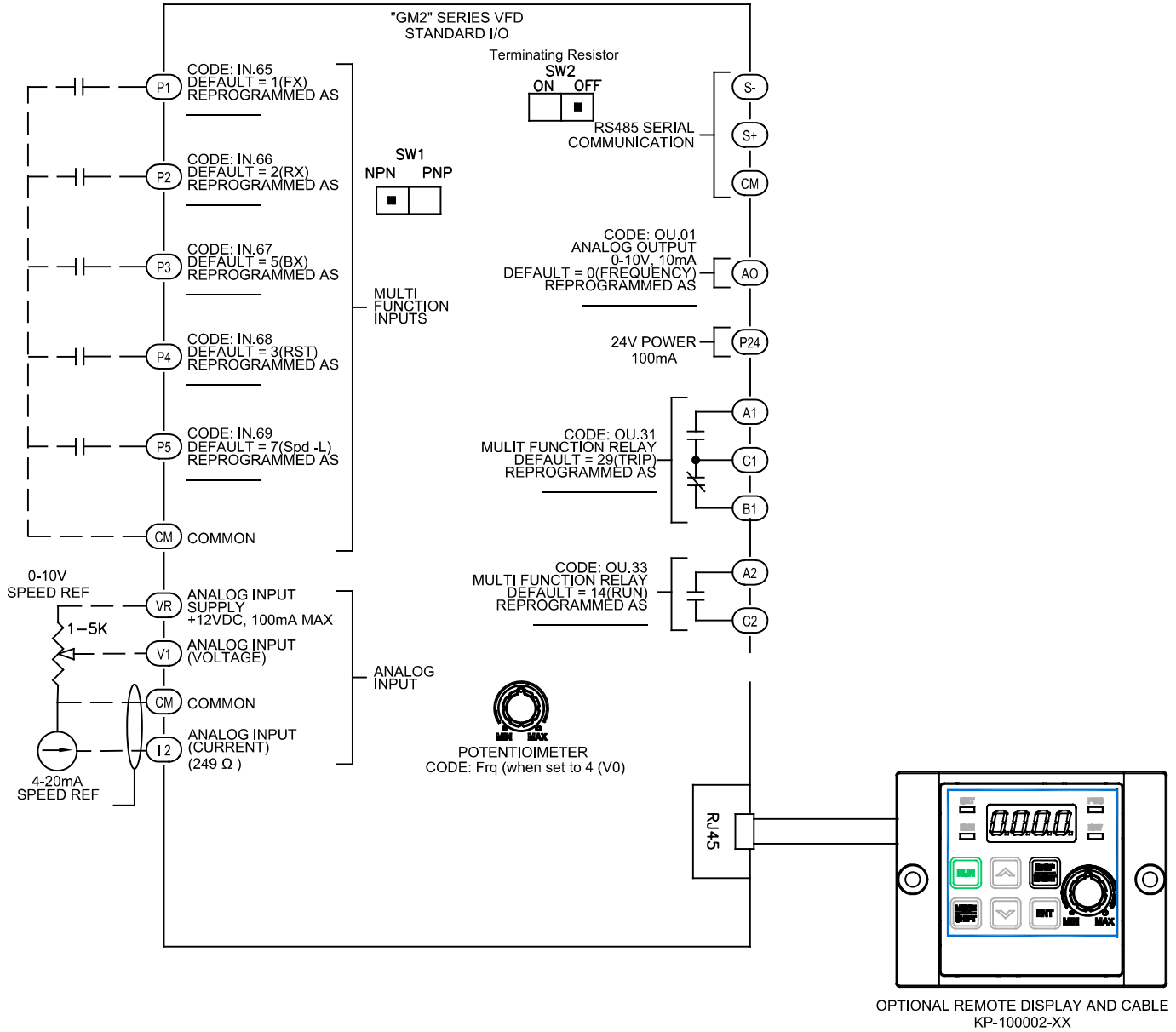

GM2 SERIES - DRAWINGS

240V, 1 HP - 2 HP

480V, 1 HP - 2 HP

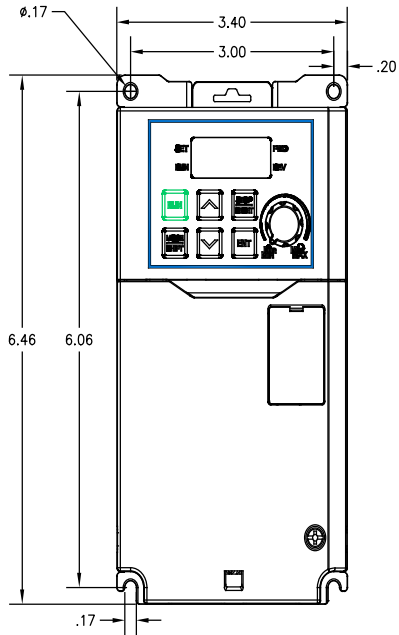

FRONT VIEW

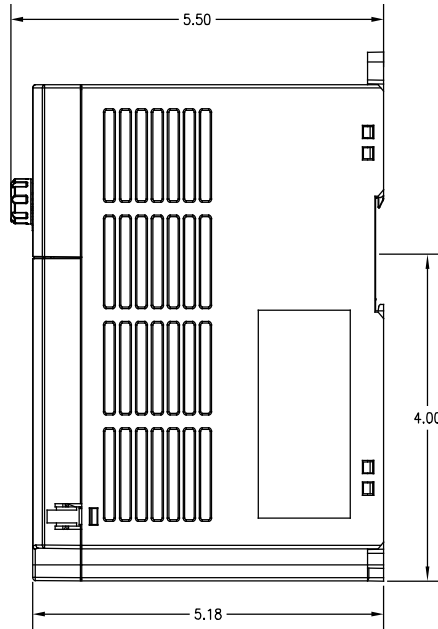

SIDE VIEW

240V, 3 HP - 5 HP

480V, 3 HP - 5 HP

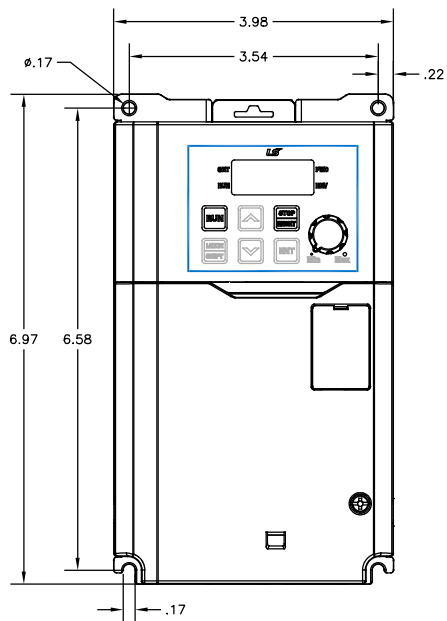

FRONT VIEW

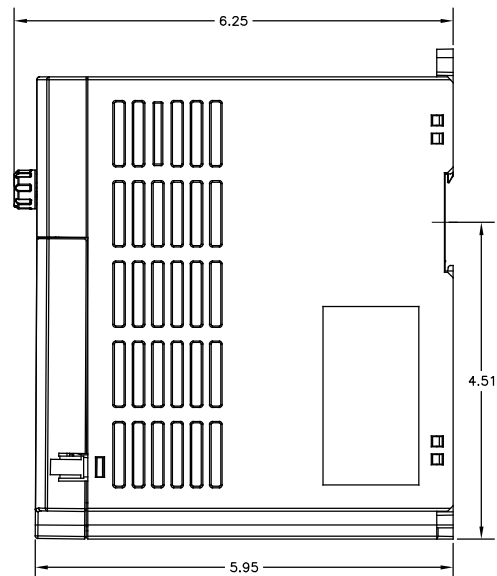

SIDE VIEW

GM2 SERIES - DRAWINGS

240V, 7.5 HP

480V, 7.5 HP

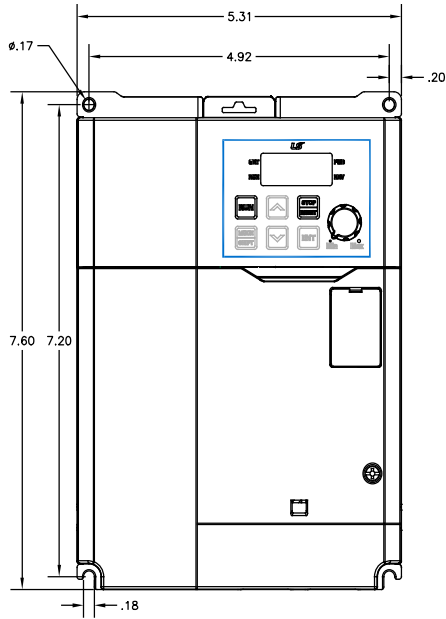

FRONT VIEW

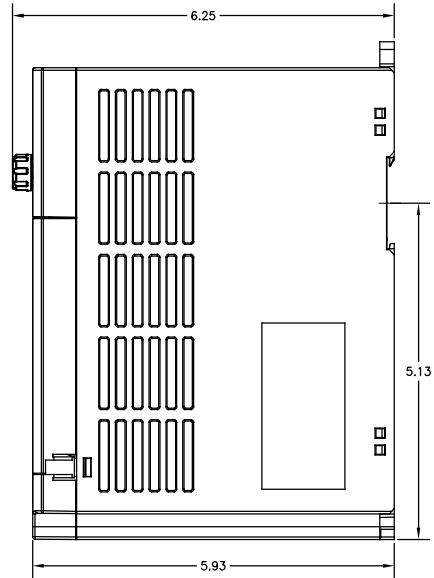

SIDE VIEW

240V, 10 HP - 15 HP

480V, 10 HP - 15 HP

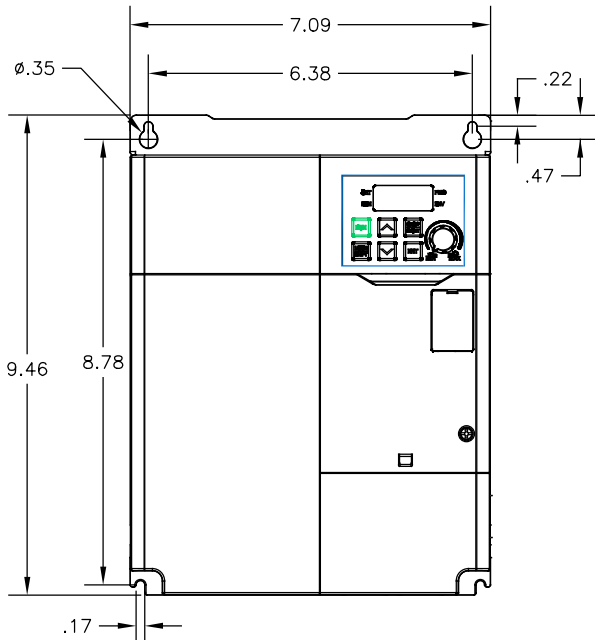

FRONT VIEW

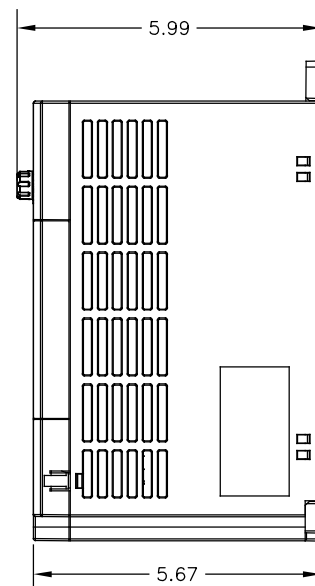

SIDE VIEW