

Introduction

As an industry leader in motor control, Benshaw is known for their offering of standard and custom engineered drive packages. If an off-the-shelf unit does not meet your needs, our dedicated team can design the drive solution you need.

Benshaw now offers a complete range of low voltage variable speed drive solutions ... from multi-purpose micro drives and high performance industrial drives to IEEE 519 clean power drives, NEMA 4X washdown duty drives and custom configured packaged drive solutions.

Benshaw GM2 Series is a sensorless vector, variable frequency drive. This micro-drive may be small...but don't let looks fool you. The GM2 Series offers enhanced performance and reliable operation in a robust, yet compact, user-friendly design. Powerful, yet small...it is the ideal choice for cost sensitive OEM or end user requirements. And it is the ideal drive for Benshaw distributors to keep in stock because of its versatility.

The **Benshaw S Series** is a compact yet powerful AC drive designed for the most demanding applications. Available in 'normal duty' ratings up to 15HP and 'heavy duty' ratings up to 10HP, the S Series puts you in control. Whether your application calls for V/Hz control, Sensorless Vector Control or Torque Control, the S Series has you covered. Modbus RTU is standard with optional communication protocols available.

The **Benshaw SW Series** NEMA 4X Washdown Drives are heavy duty rated for applications from 0.5-30HP. Designed for high pressure washdown, all SW Series drives feature a rugged UL Type 4X (IP66) indoor rated polycarbonate enclosure that exceeds NEMA 1, 12, 4 and 4X standards. A convenient built-in power disconnect switch, 4 digit, 7-segment display and an optional remote LCD Display/Keypad with a Quick Start menu, make it easy to program and control.

The **Benshaw H2 Series** sets the new standard for variable frequency drives. It can be used as a general purpose industrial drive with V/hz or Vector control (with ratings for normal or heavy duty applications from 5-800HP). For fan and pumps applications, simply use the built-in macros designed to meet the basic requirements of the water/wastewater, irrigation and HVAC industries. Built in communication protocols include Modbus-RTU, BACnet and Metasys-N2.



S SERIES - MICRO DRIVES

The Benschaw S Series is a compact yet powerful AC drive designed for the most demanding applications. Available in 'normal duty' ratings up to 15HP and 'heavy duty' ratings up to 10HP, the S Series puts you in control. Whether your application calls for V/Hz control, Sensorless Vector Control or Torque Control, the S Series has you covered. Modbus RTU is standard with optional communication protocols available. And, as with all Benschaw AC drives, the S Series complies with industrial standards including UL/cUL, CE and includes built-in EMC filters (480V models) and Safe Torque Off (STO) input. The best part about the S Series drive is how easy it is to convert from an IP20 protected chassis to a UL Type 1 per UL 61800-5-1 rating with the addition of a convenient conduit box (a standard Benschaw stock item). A plenum rating per UL 2043 is also achieved with the addition of the conduit box.



FEATURES

Dual Rated:

- Normal Duty up to 15HP
- Heavy Duty up to 10HP

Control Modes:

- V/Hz Control
- Sensorless Vector (IM and PMAC)
- Slip Compensation
- Torque Control

Hardware:

- Compact Size
- EMC Filter Built in (460V only)
- Internal Brake IGBT (external resistor required)
- Single Phase Input (derating required)
- IP20 Protected Chassis Enclosure Standard

Functions:

- PID Control
- Kinetic Energy Buffering (KEB) for power loss ride through
- Regen Avoidance for press applications
- Fire Pump Mode
- STO (Safe Torque Off)
- Energy Savings
- Flying Start
- PLC Functionality with 18 steps user programmable sequence
- Peer to Peer communications for Master/Slave Control

OPTIONS

- Extended I/O Card
- Remote LCD Display/Keypad
- Conduit Box for UL Type 1 and Plenum rating
- Adapter Flange for Fins Out Cooling

COMMUNICATIONS

- Ethernet IP/Modbus -TCP
- Profibus -DP
- Profinet
- CANopen

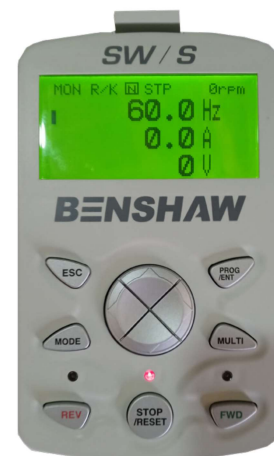

S SERIES - PRICING

Model Number	Normal Duty 120% for 60 sec.		Heavy Duty 150% for 60 sec.		Dimensions (inches)			List Price
	HP	Amps	HP	Amps	H	W	D	
VFD-RSI-001-SS-2C	1	3.1	0.5	2.5	5.04	2.68	4.84	\$659
VFD-RSI-002-SS-2C	2	6	1	5	5.04	2.68	5.04	\$757
VFD-RSI-003-SS-2C	3	10	2	8	5.04	3.94	5.12	\$824
VFD-RSI-005-SS-2C	5	12	3	11	5.04	3.94	5.71	\$965
VFD-RSI-007-SS-2C	7.5	18	5.4	17	5.04	5.51	5.71	\$1,173
VFD-RSI-010-SS-2C	10	30	7.5	24	9.13	6.3	5.51	\$1,708
VFD-RSI-015-SS-2C	15	40	10	32	9.13	6.3	5.51	\$2,089

Model Number	Normal Duty 120% for 60 sec.		Heavy Duty 150% for 60 sec.		Dimensions (inches)			List Price
	HP	Amps	HP	Amps	H	W	D	
VFD-RSI-001-SS-4C	1	2.0	0.5	1.3	7.09	2.68	5.12	\$879
VFD-RSI-002-SS-4C	2	3.1	1	2.5	7.09	2.68	5.12	\$957
VFD-RSI-003-SS-4C	3	5.1	2	4	7.09	3.94	5.51	\$965
VFD-RSI-005-SS-4C	5	6.9	3	5.5	7.09	3.94	5.51	\$1,008
VFD-RSI-007-SS-4C	7.5	10	5.4	9	7.09	5.51	5.51	\$1,242
VFD-RSI-010-SS-4C	10	16	7.5	12	9.13	6.3	5.51	\$1,764
VFD-RSI-015-SS-4C	15	23	10	16	9.13	6.3	5.51	\$2,137

S SERIES - ACCESSORIES

DISPLAY / KEYPAD REMOTE MOUNTING

Part Number	Description	List Price
LCD-100004-00	Remote LCD Display/Keypad, S & SW Series VFD	\$184
VFD-2M-RE-CABLE-H2	Bezel & Cable, RJ45, 2M, S/SW/H2 Series VFD, for Remote Mounting	\$46
VFD-3M-RE-CABLE-H2	Bezel & Cable, RJ45, 3M, S/SW/H2 Series VFD, for Remote Mounting	\$63
CV-100017-00	LCD Cover, Remote Mounting, NEMA 4X, S, SW & H2 Series VFD	\$278

COMMUNICATION CARDS AND I/O CARDS

Part Number	Description	List Price
PC-100090-00	Extended I/O Card, S & SW Series VFD	\$430
PC-100092-00	Ethernet IP & Modbus TCP Option Card	\$339
PC-100091-00	Profibus-DP Option Card*	\$61
PC-100094-00	CANopen Option Card	CF
PC-100095-00	Profinet Option Card	\$677

* Profibus cannot be use with SW VFD.
 CF Consult Factory

NEMA 1 CONDUIT KITS

Part Number	Description	List Price
EN-100994-00	Conduit Box, 1 HP~2 HP, 230V	\$70
EN-100994-01	Conduit Box, 3 HP~5 HP, 230V	\$72
EN-100994-02	Conduit Box, 7.5 HP, 230V	\$77
EN-100994-03	Conduit Box, 10 HP~15 HP, 230V/460V	\$83
EN-100994-04	Conduit Box, 1 HP~2 HP, 460V	\$70
EN-100994-05	Conduit Box, 3 HP~5 HP, 460V	\$72
EN-100994-06	Conduit Box, 7.5 HP, 460V	\$83

FINS OUT MOUNTING FLANGES

Part Number	Description	List Price
BRKT-100770-00	Mounting flange, 1 HP~2 HP, 230V	\$197
BRKT-100770-01	Mounting flange, 3 HP~5 HP, 230V	\$198
BRKT-100770-02	Mounting flange, 7.5 HP, 230V	\$198
BRKT-100770-03	Mounting flange, 10 HP~15 HP, 230V/460V	\$198
BRKT-100770-04	Mounting flange, 1 HP~2 HP, 460V	\$184
BRKT-100770-05	Mounting flange, 3 HP~5 HP, 460V	\$195
BRKT-100770-06	Mounting flange, 7.5 HP, 460V	\$195

Price Effective July 1, 2025

S SERIES - INPUT AND OUTPUT SPECIFICATIONS

3-Phase 240V, 1 HP - 15 HP (0.75 - 11 kW)

RSI-XXX-SS-2C			001	002	003	005	007	010	015
240V, w/3Ø Input	Normal Duty 120% OL	HP	1	2	3	5	7.5	10	15
		kW	0.75	1.5	2.2	3.7	5.5	7.5	11
		Amps	3.1	6	10	12	18	30	40
		KVA	1.2	2.3	3.8	4.6	6.9	11.4	15.2
	Heavy Duty 150% OL	HP	0.5	1	2	3	5.4	7.5	10
		kW	0.4	0.75	1.5	2.2	4	5.5	7.5
		Amps	2.5	5	8	11	17	24	32
		KVA	1	1.9	3	4.2	6.5	9.1	12.2
240V, w/1Ø Input	Normal Duty 120% OL	HP	-	0.75	1	1.5	3	5	7.5
		Amps	1.8	3.3	5.7	6.6	9.9	16	22
	Heavy Duty 150% OL	HP	-	0.5	1	1.5	2	3	5
		Amps	1.5	2.8	4.6	6.1	9.3	13	18
Rated Output	Output frequency		0.00~400.00 (Hz), V/F, Slip Compensation						
			0.00~120.00 (Hz), IM Sensorless						
			0.00~180.00 (Hz), PM Sensorless						
Output voltage (V)		3-phase 0-240 V							
Rated Input	Working voltage (V)		3-phase 200-240 VAC (-15% to +10%)						
			1-phase 240 VAC (-5% to +10%)						
	Input frequency		3-phase 50-60 Hz (±5%)						
			1-phase 60Hz (±5%.)						
	3-phase current (A)	Normal Duty	3	6.3	10.8	13.1	19.4	32.7	44.2
Heavy Duty		2.2	4.9	8.4	11.8	18.5	25.8	34.9	
Weight (lb/kg)		lbs	2	2	2.86	3.3	4.4	7.3	7.3
		kg	0.9	0.9	1.3	1.5	2	3.3	3.3

S SERIES - INPUT AND OUTPUT SPECIFICATIONS

3-Phase 480V, 1 HP - 15 HP (0.75 - 11 kW)

RSI-XXX-SS-2C			001	002	003	005	007	010	015
480V, w/3Ø Input	Normal Duty 120% OL	HP	1	2	3	5	7.5	10	15
		kW	0.75	1.5	2.2	3.7	5.5	7.5	11
		Amps	2	3.1	5.1	6.9	10	16	23
		KVA	1.5	2.4	3.9	5.3	7.6	12.2	17.5
	Heavy Duty 150% OL	HP	0.5	1	2	3	5.4	7.5	10
		kW	0.4	0.75	1.5	2.2	4	5.5	7.5
		Amps	1.25	2.5	4	5.5	9	12	16
		KVA	1	1.9	3	4.2	6.5	9.1	12.2
480V, w/1Ø Input	Normal Duty 120% OL	HP	0.5	0.75	1.5	2	3	5	10
		Amps	1.3	1.9	3	3.9	5.9	9.5	14
	Heavy Duty 150% OL	HP	-	0.5	0.75	1	2	2	3
		Amps	0.8	1.5	2.3	3.1	5.4	7.1	9.5
Rated Output	Output frequency		0.00~400.00 (Hz), V/F, Slip Compensation						
			0.00~120.00 (Hz), IM Sensorless						
			0.00~180.00 (Hz), PM Sensorless						
Output voltage (V)		3-phase 0-480 V							
Rated Input	Working voltage (V)		3-phase 380-480 VAC (-15% to +10%)						
			1-phase 480 VAC (-5% to +10%)						
	Input frequency		3-phase 50-60 Hz (±5%)						
			1-phase 60Hz (±5%.)						
	3-phase current (A)	Normal Duty	2	3.3	5.5	7.5	10.8	17.5	25.4
Heavy Duty		1.1	2.4	4.2	5.9	9.8	12.9	17.5	
Weight (lb/kg) w/EMC filter		lbs	2.6	2.6	3.9	4.1	4.9	7.3	7.5
		kg	1.18	1.18	1.77	1.8	2.23	3.3	3.4

S SERIES - PRODUCT SPECIFICATION DETAILS

Feature		Description			
Control	Control method	V/F control, Slip Compensation, Sensorless Vector (IM and PM), IM Torque Control			
	Frequency settings resolution	Digital command: 0.01 Hz	Analog command: 0.06 Hz (60Hz standard)		
	Frequency accuracy	1% of maximum output frequency			
	V/F pattern	Linear, Square Reduction, User V/F			
	Overload capacity	Normal Duty: 120%, 1 minute	Heavy Duty: 150%, 1 minute		
	Torque boost	Manual torque boost, Automatic torque boost			
Operation	Operation Type				
	Start/Stop	Keypad, terminal strip or communications			
	Frequency settings	Analog type: 0~10V, 0/4~20mA, -10~10V Digital type: Keypad, Pulse Train input, communications			
	Operation function	Basic		Advanced	
		Start/Stop Operation	Sensorless Vector Control		
		Start/Stop Modes	IM and PM motors		
		Frequency Reference Sources	Auto Tuning		
		Auxiliary Frequency Reference	Torque Control, Torque Limits		
		Multi-Step Speeds	PID Control		
		Multi-Step Accel/Decel Times	Slip Compensation		
		2nd Source (HOA)	Energy Save Mode		
		Accel/Decel Times	Regen Avoidance		
		Accel/Decel Patterns	VFD Fan Control		
		Dwell Frequency Operation			
		Jog	Loss of Power		
		Auto Start	Ride Through (KEB)		
		Auto Reset/Restart	Safe Stop		
			Speed Search		
		V/Hz. Control Pattern			
		Linear, Squared, User V/Hz	Braking		
		Torque Boost	DC Injection Braking		
			Stall Prevention		
		FWD/REV Run Prevention	Power Braking		
		Frequency Limits	Flux Braking		
		Jump Frequencies	External Brake Control		
		3-Wire Control			
		Fire Mode			
	Input	(5) Multi-function input terminal (P1 - P5)	Select PNP (Source) or NPN (Sink) mode		
			Functions of the digital inputs are set with parameters In.65 - In.69		
			• Forward/Reverse	• Run Enable (Interlock)	
• Reset			• External trip		
• Emergency stop			• Jog operation (FWD/REV)		
• Multi-Step frequencies			• Multi-step Accel/Decel		
• DC braking during stop			• Second motor selection		
• Frequency increase			• Up/Down Frequency		

S SERIES - PRODUCT SPECIFICATION DETAILS

Feature		Description			
Operation	Input	(5) Multi-function input terminal (P1 -P5)	<ul style="list-style-type: none"> 3-Wire Accel/Decel/Stop Analog Hold (frequency) Exit PID Operation Auxiliary Input (2nd Source), HOA 		
		Pulse Train	0-32 kHz, Low Level: 0-2, 5V, High Level: 3, 5-12V		
	Output	Open collector (Q1)	Less than DC 24V, 50mA		
		Relay, R1	Fault output, VFD operating status, many others Less than AC 250V, 1A Less than DC 30V, 1A		
		Analog Output	0/4-20mA / 0-12 VDC (Switch Selectable): Select frequency, output current, output voltage, DC terminal voltage and others		
		Pulse Train	Maximum 32kHz, 10-12V		
			<ul style="list-style-type: none"> Motor Overload Motor Under Load Over Current (OC1) Over Voltage Low Voltage Ground Fault Motor Over Heat (Eth) Phase Open (In/Out) Inverter Overload No Motor Trip Over Torque Safety (STO) A, B Trip Under Torque Inverter Over Heat Short Circuit (OC2) External Trip Hardware Fault Temperature Sensor (NTC) Fan Fault Pre-PID Operation Failure External Brake Trip Reference Loss Option Board Trip Loss of Communications 		
			Alarm	Warnings: Reference Loss, Motor Overload, Motor Under Load, Inverter Overload, Fan, Dynamic Braking Rate Warning, Auto Tuning Error, Inverter Overheat	
			Instantaneous Loss of Power	Normal Duty: Less than 8 ms (~ 1/2 cycle)	
				Heavy Duty: Less than 15 ms (~ 1 cycle)	
				For longer outages use KEB operation and/or Auto Restart operation	
			Structure / working environment	Cooling type	Forced cooling type: 240V: 2 HP ~ 15 HP 480V: 1 HP ~ 15 HP
				Protection structure	IP20, UL Open Type
					UL Type 1 is achieved with conduit box installation (option)
				Ambient temperature	14°F ~+ 104°F (- 10°C ~ + 40°C)
					Derating: 2% output amps for every degree above 104°F (40°C) maximum 122°F (50°C)
Ambient humidity				Less than 90% RH (to avoid condensation forming)	
Storage temperature				- 4°F ~ + 149°F (- 20°C ~ + 65°C)	
Surrounding environment	Prevent contact with corrosive gases, inflammable gases, oil stains, dust, and other pollutants (Pollution Degree 2 Environment)				
Operation altitude/oscillation	3,280 ft (1000 m). Apply derating of 1% voltage/output current for every 328 ft (100m) above 3,280 ft (1,000 m), maximum of 13,123 ft (4,000 m)				
	Less than 9.8 m/sec ² (1G)				
Pressure	10 ~ 15 PSI (70 ~ 106 kPa)				

S SERIES - WIRING

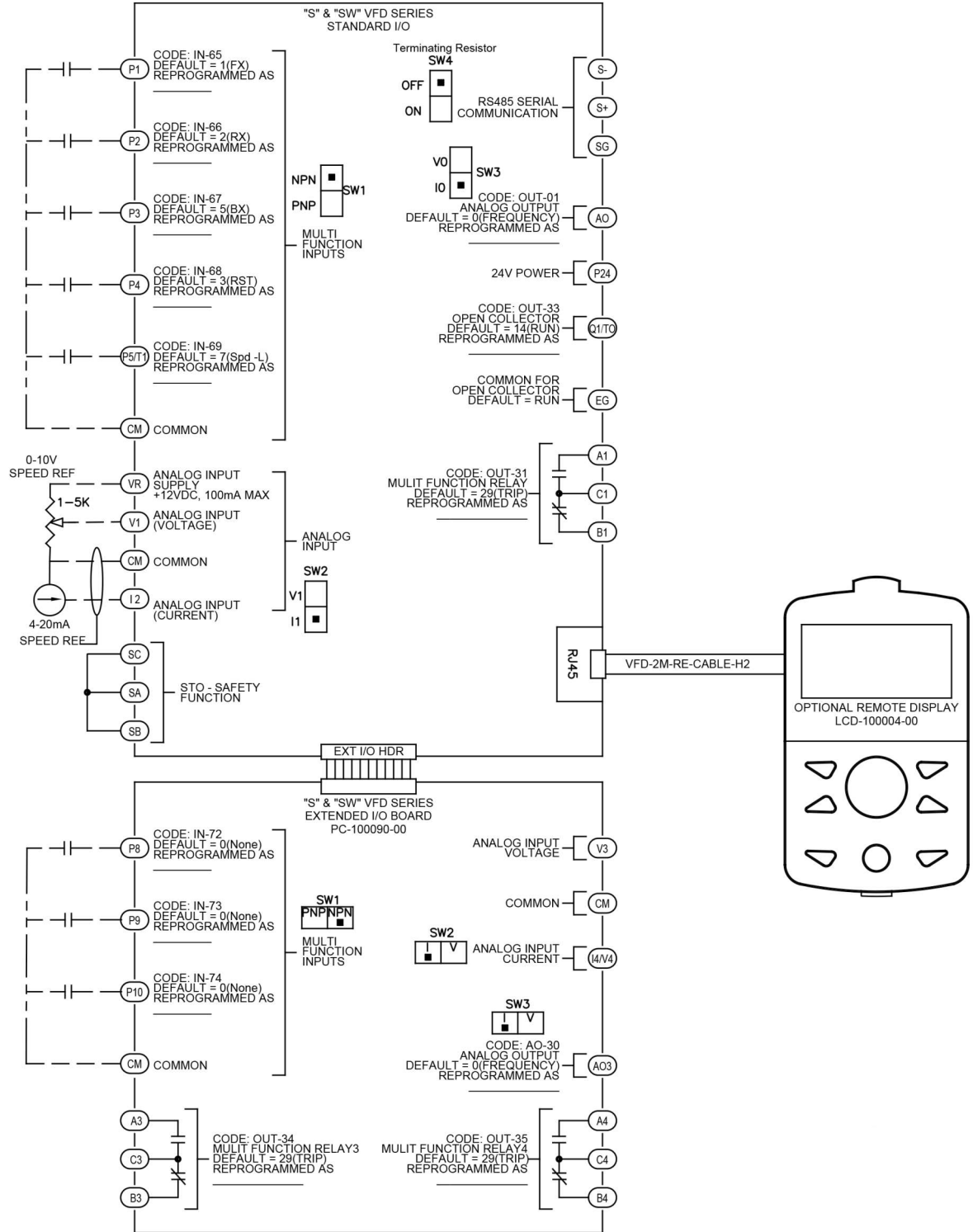

S SERIES - DRAWINGS

240V, 1 HP

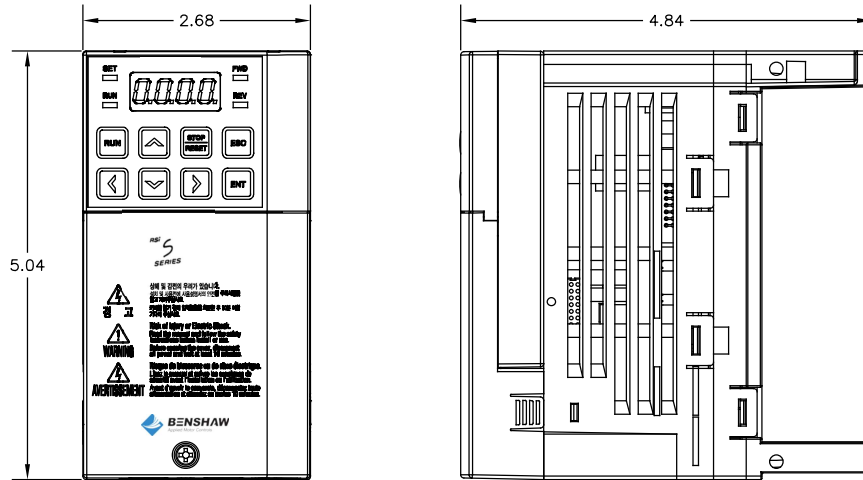

240V, 2 HP

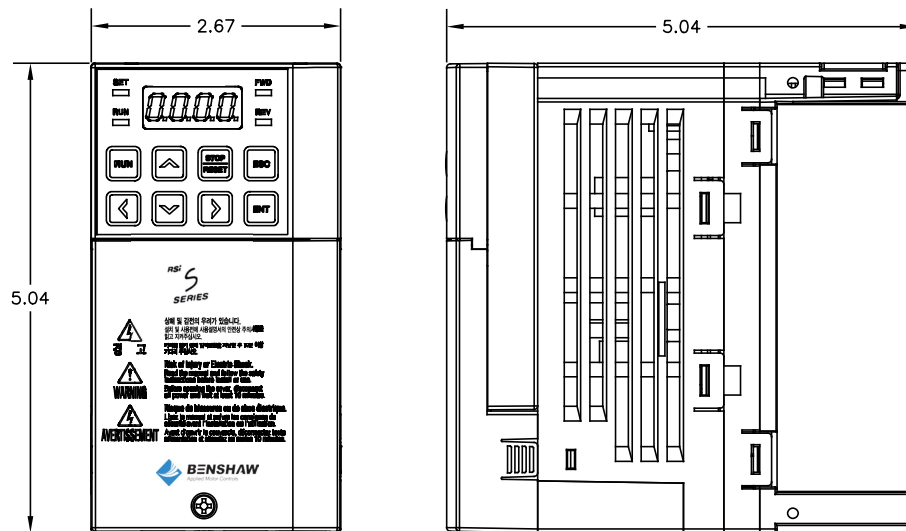

240V, 3 HP

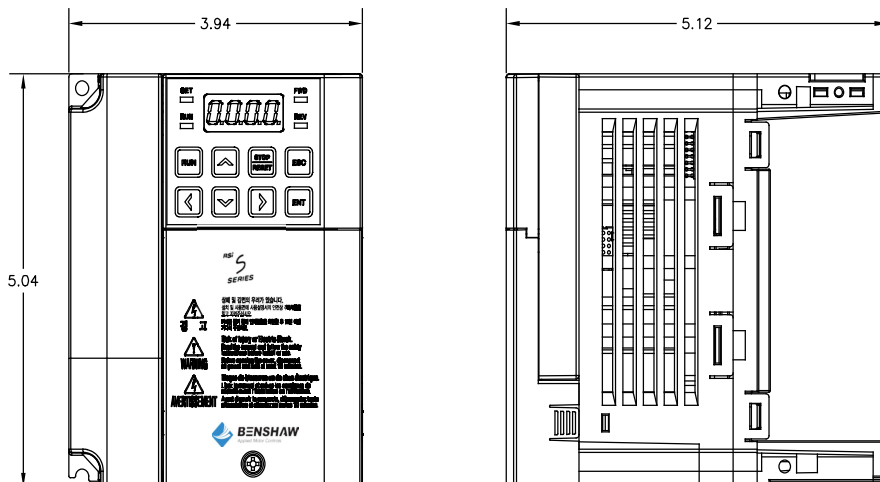

S SERIES - DRAWINGS

240V, 5 HP

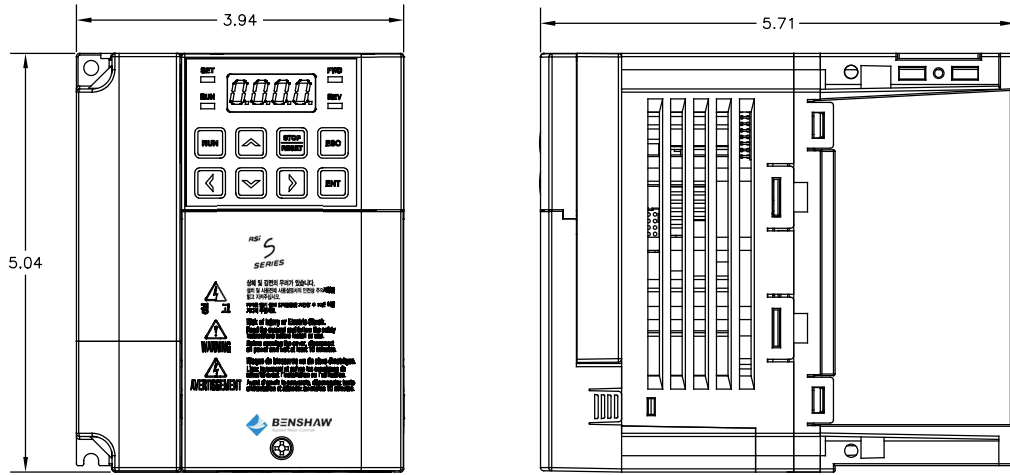

240V, 7.5 HP

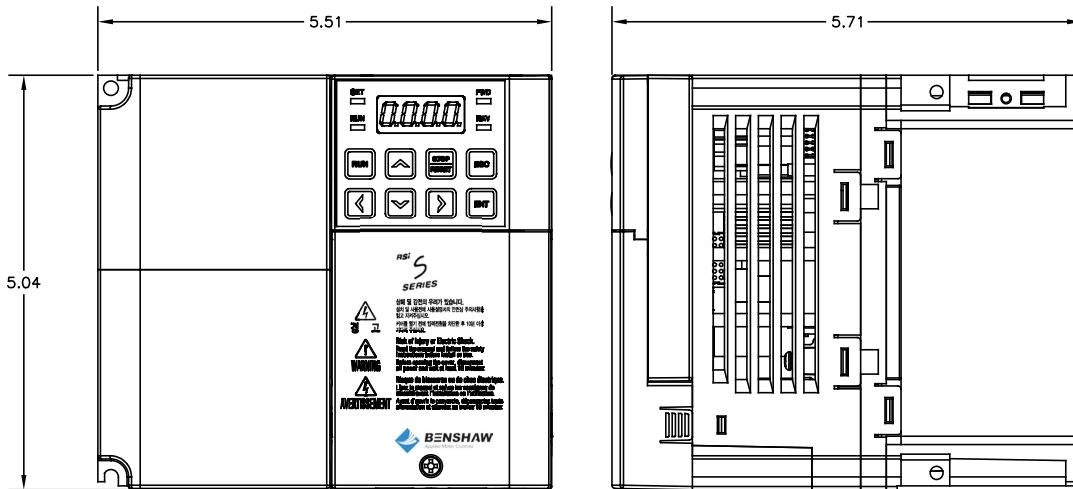

240V, 10 HP - 15 HP
480V, 10 HP - 15 HP

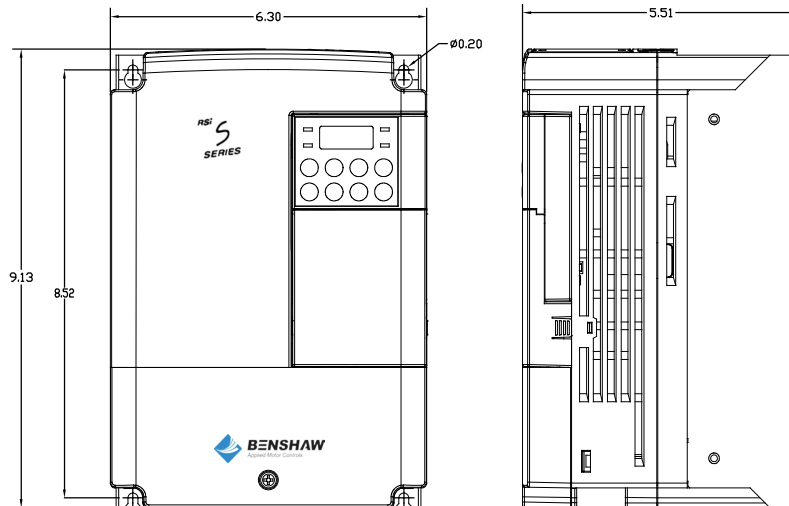

FRONT VIEW

SIDE VIEW

S SERIES - DRAWINGS

480V, 1 HP - 2 HP

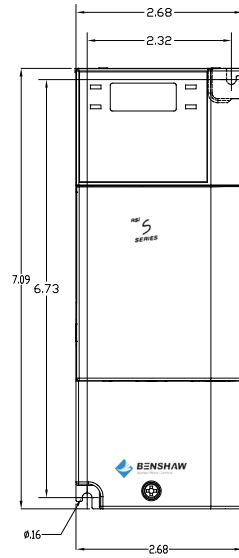

FRONT VIEW

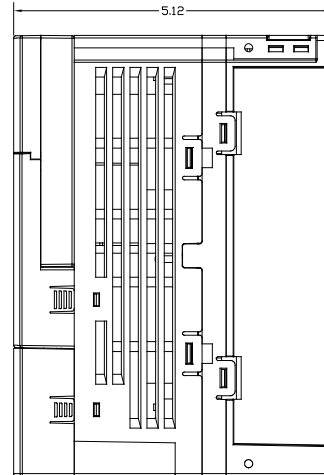

SIDE VIEW

480V, 3 HP - 5 HP

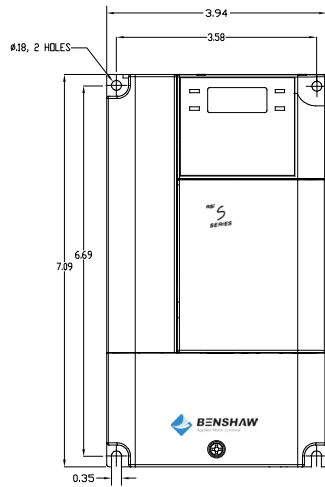

FRONT VIEW

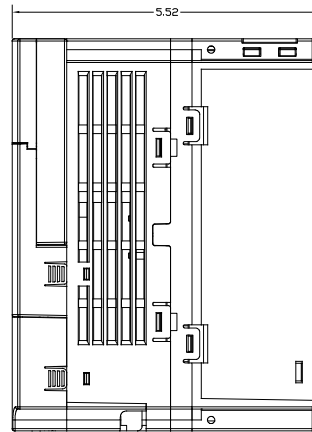

SIDE VIEW

480V, 7.5 HP

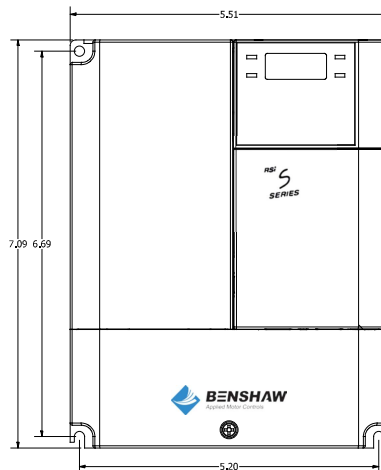

FRONT VIEW

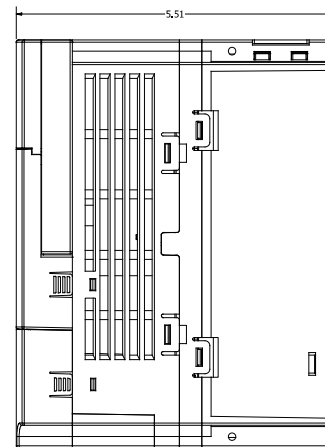

SIDE VIEW