



Gear & Engineering Corp.

011-348-4010

300_series Parallel Shaft Gearmotor

Product Series	300	Weight (Lbs)	20
Speed (RPM)	170	Output Shaft Diameter (In)	0.75
Torque (InLb)	90	Lubrication (Type)	Oil
Ratio :1	10.6	Motor Size Input	NA
Input Hp (HP)	1/4	Construction File	E89715
Input Hp (HP)	0.25	Insulation File	E199928
Volts (V)	90	Construction File	150393
Amps (A)	2.51	CE Certification	No
Overhung Load (Lbs)	240		

011-348-4010

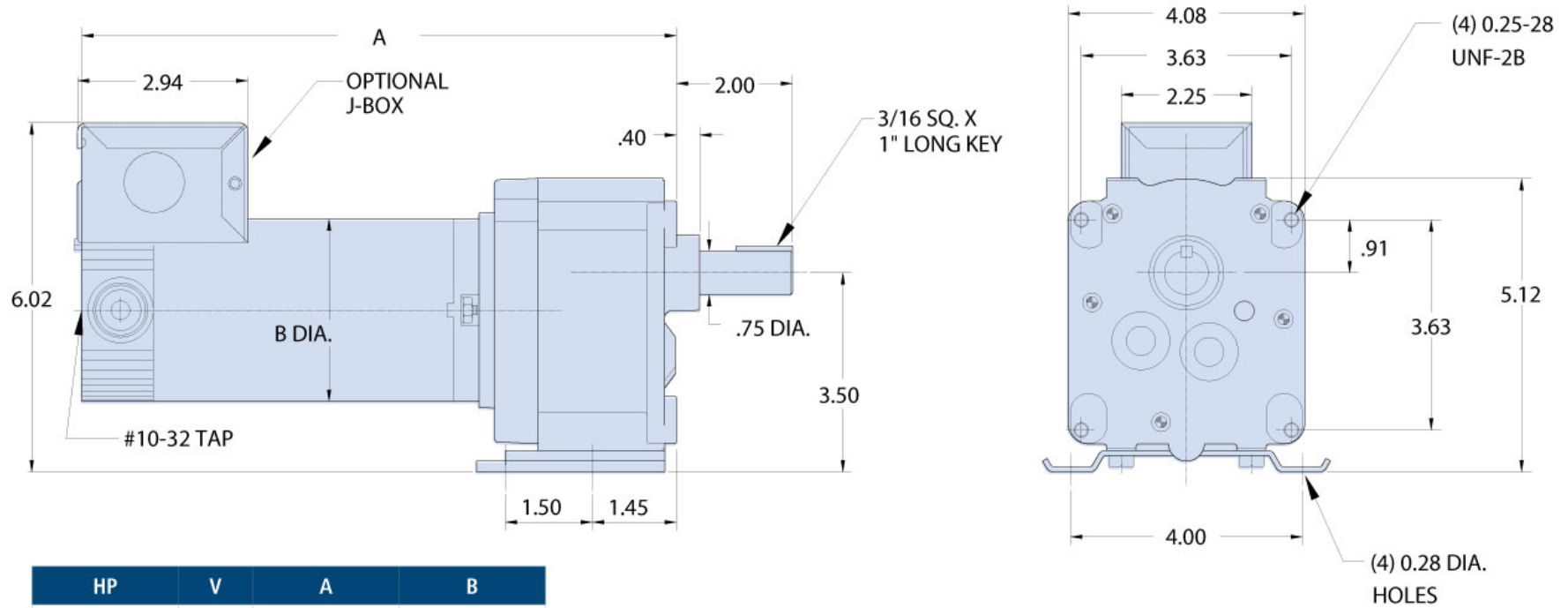

HP	V	A	B
1/8	90	10.26	3.13
1/8	24	10.34	3.13
1/4	90	12.26	3.38