

REV	DATE	DESCRIPTION	ECO	BY	C.H.K.
F	07/09/2015 00:00:00 AM	ADDED NOTE "DO NOT USE PAT644 OR Y644 TOOLING WITH 6 AWG SOL"	40916	SPR	MA

CATALOG NUMBER	STRANDED COPPER CONDUCTOR ACCOMMODATED			BOLT SIZE	METRIC BOLT SIZE	DIMENSIONS								
	CODE (AWG)	NAVY	METRIC SIZE (CLASS 2)			B	C	E	K DIA.	L	N	O.D.	T REF.	Z MIN.
YA6CL2TC10E1	#6 STR #6 SOL	-----	-----	#10	----	.54 [14]	.42 [11]	1.00 [25]	.21 [5]	2.32 [59]	.25 [6]	.29 [7]	.09 [2]	.27 [7]
YA6C2L51				#10	----	.42 [11]	.50 [13]	.21 [5]	1.79 [46]	.22 [6]	.09 [2]	.27 [7]		
YA6CL2TC10				#10	----	.42 [11]	.62 [16]	.21 [5]	1.94 [49]	.25 [6]	.09 [2]	.27 [7]		
YA6CL2TC10E2				#10	----	.42 [11]	.75 [19]	.21 [5]	2.07 [53]	.25 [6]	.09 [2]	.27 [7]		
YA6C2L52				1/4	M6	.45 [11]	.50 [13]	.27 [7]	1.88 [48]	.25 [6]	.08 [2]	.33 [8]		
YA6C2L				1/4	M6	.62 [16]	.50 [13]	.25 [6]	2.01 [51]	.25 [6]	.34 [9]			
YA6CL2TC14E				1/4	M6	.62 [16]	.50 [13]	.31 [8]	1.94 [49]	.31 [8]	.33 [8]			
YA6CL2TC14				1/4	M6	.62 [16]	.62 [16]	.31 [8]	2.07 [53]	.31 [8]	.33 [8]			
YA6CL2TC14G1				1/4	M6	.62 [16]	.62 [16]	.31 [8]	2.07 [53]	.31 [8]	.33 [8]			
YA6CL2TC14E2				1/4	M6	.75 [19]	.75 [19]	.31 [8]	2.19 [56]	.31 [8]	.33 [8]			
YA6CL2TC14E1				1/4	M6	.45 [11]	1.00 [25]	.27 [7]	2.44 [62]	.41 [10]	.08 [2]	.33 [8]		
YA6CL2TC38				3/8	----	.58 [15]	1.00 [25]	.39 [10]	2.63 [67]	.41 [10]	.06 [2]	.42 [11]		
YA6CL2TC38E10				3/8	----	.58 [15]	1.25 [32]	.41 [10]	2.88 [73]	.41 [10]	.06 [2]	.42 [11]		

CONNECTOR SIZE	TOLERANCES						
	B	C	E	K DIA.	L	N	O.D.
-8C THRU -25	±.06	±.04	±.02	±.02	±.09	±.03	±.01
-26 THRU -34	±.08	±.04	±.02	±.02	±.12	±.03	±.01
-35 AND UP	±.09	±.06	±.02	±.02	±.15	±.06	±.01

TOLERANCE BLOCK

CATALOG NO.	COLOR CODE	DIE INFORMATION		MECHANICAL				HYDRAULIC						DIELESS (# CRIMPS)	WIRE STRIP LENGTH	
		DIE INDEX	TYPE	Y1MRTC Y122CMR	OUR840	MD6 MD7	MD6--R2 MD7-34R	Y500CT PAT600 PATMD6	Y34A Y34B Y34BH	Y35, Y39 Y750, PAT750	Y46 PAT46	Y45	Y48B			Y60BHU
ALL LISTED ABOVE	BLUE	7 374	BLUE DIE SET NEST INDENTOR	BLUE (1)	X5CRT(1) X8CART(1)	W5CRT(1) W5CVT(1)	W5CRT(1) W5CVT(1)	X5CRT (1) X8CART(1) W5CRT (1) W5CVT (1)	----	U5CRT(1) U8CABT(1)	U5CRT(1) U8CABT(1)	U5CRT(1) U8CABT(1)	----	----	MECHANICAL: MY29-3(1) MY29-11(1) MRC840(1) HYDRAULIC: Y81KFT(1) Y4PC834(1) Y644(1)	5/8"

- NOTES:
- MATERIAL: COPPER TUBING.
 - FINISH: TIN PLATED.
 - CATALOG # PT6515 ADAPTOR IS REQUIRED TO USE "U" DIES IN Y45 SERIES TOOLS.
 - CATALOG # PUADP-1 ADAPTOR IS REQUIRED TO USE "U" DIES IN Y46 SERIES TOOLS.
 - Y35P3 INDENTOR ADAPTOR REQUIRED FOR Y34PR INDENTOR.
 - PERMANENT DIE IN TOOLING.
 - DIMENSIONS IN BRACKETS [] ARE IN MILLIMETERS ROUNDED OFF TO THE NEAREST MILLIMETER UNLESS OTHERWISE NOTED, AND ARE FOR REFERENCE ONLY.
 - FOR USE BY CUSTOMERS THAT HAVE THIS HYPRESS™. NO NEW Y34A HYPRESS™ TOOLS ARE BEING PROCESSED. Y34A USES A--D TYPE NEST DIES.
 - CONNECTORS ARE "UL" LISTED; UNDRILLED VERSIONS ARE NOT "UL" LISTED.
 - CONNECTORS ARE "CSA" CERTIFIED; UNDRILLED VERSIONS ARE NOT "CSA" CERTIFIED.
 - FOR UNDRILLED VERSIONS ADD SUFFIX "-U" TO END OF CATALOG NUMBER. FOR UNDRILLED VERSIONS, USE D MIN. = N MAX. + E MIN. + Z MIN.
 - "X", "W-RT", "W-VT", "U", & "L" DIE SETS ARE COLOR CODED. "A", "B" & "C" DIES ARE NOT COLOR CODED. NESTS AND INDENTOR TYPE ARE NOT COLOR CODED.
 - YA6CL2TC14G1 DOES NOT HAVE COLOR CODE.

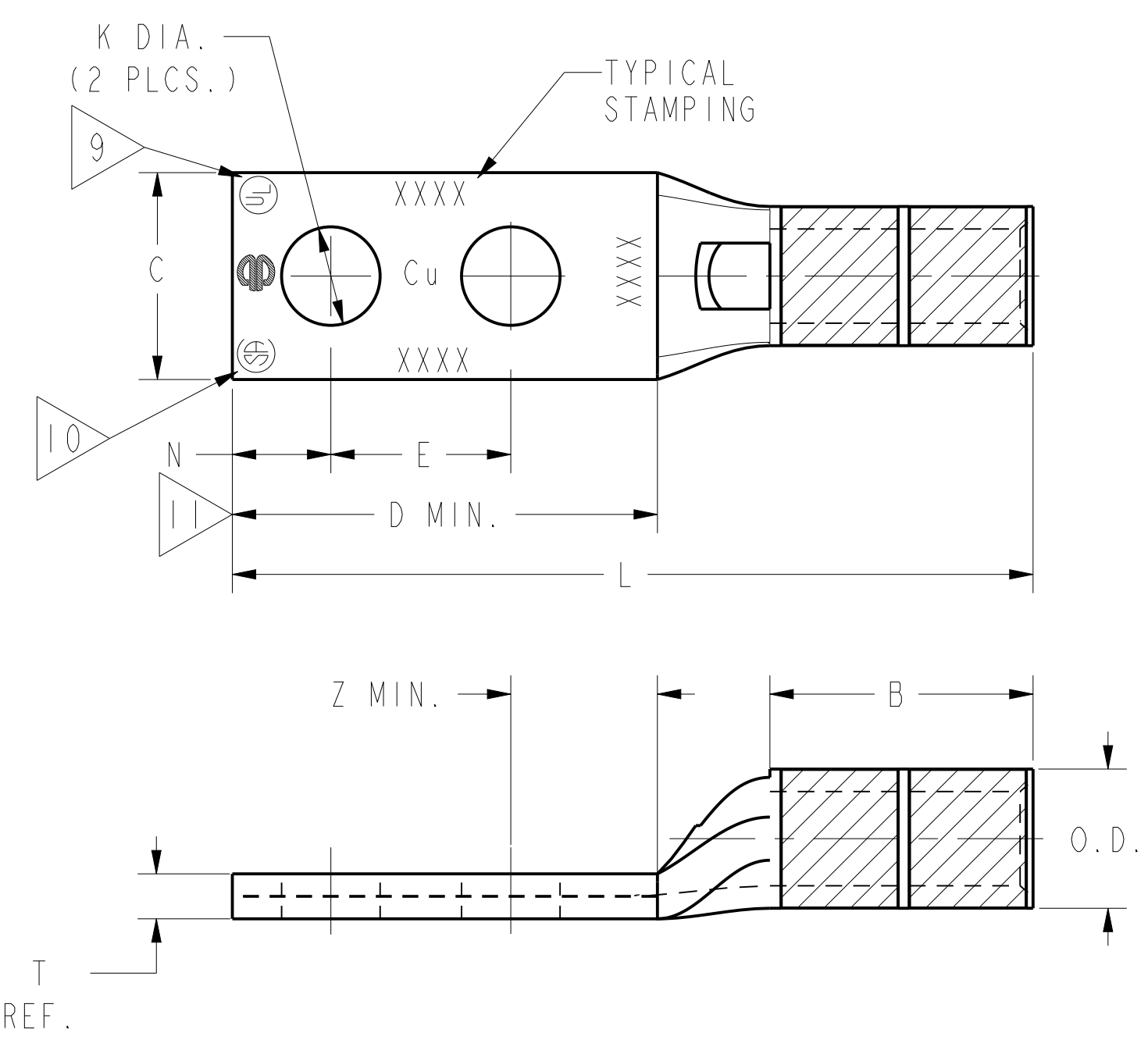

DO NOT USE PAT644 OR Y644 TOOLING WITH 6 AWG SOL.

REFERENCE : SE209512
SUPERSEDES : SC91923

HYLUG™	
ITEM NO:	N/A
CAT. NO:	YA6C-2L-, YA6CL-2TC- (TABLE)
DRAWN BY:	J. MICHAUD 11/18/94
CHECKER:	D. FILLION 11/18/94
DSN APPVL:	C. PALAGI 10/24/94
MFG APPVL:	--
QA APPVL:	C. ACKERMAN 11/17/94
MKT APPVL:	--
PROD FAM:	CM&R COMPRESSION
PROJECT #:	SIZE
DOCUMENT TYPE:	SD035209
REL LEVEL:	Released
SCALE: NTS	
DRAWING NO	REV
SD035209	F
SHEET 3 OF 18	

REV: PEC200