

CAT. NO.	WIRE RANGE	STUD SIZE [METRIC SIZE]	HYDRAULIC TOOLING					DIELESS TOOLING 4	NO. CRIMPS 4	WIRE STRIP LENGTH	
			DIE INDEX	TOOL CAT. NO.							
YAD33M16E58	400-450 Kcmil STR.CU CODE & FLEX [185-240]mm <sup>2</sup>	5/8" [16]	----	Y46, PAT46			Y750, PAT750		Y81KFT- SERIES PAT81KFT- SERIES Y4PC834- SERIES PAT4PC834- SERIES	1	1-3/8"
				ADAPTOR	NEST	INDENTOR	NEST	INDENTOR			
				---	P44D	P48PR2	UM33N	UME			
				PUADP1	UM33N	UME					

REV	DATE	DESCRIPTION	ECO	BY	C'H'K.
B	8/19/2014	UPDATED AS PER MARKUP	37422	DK	MA

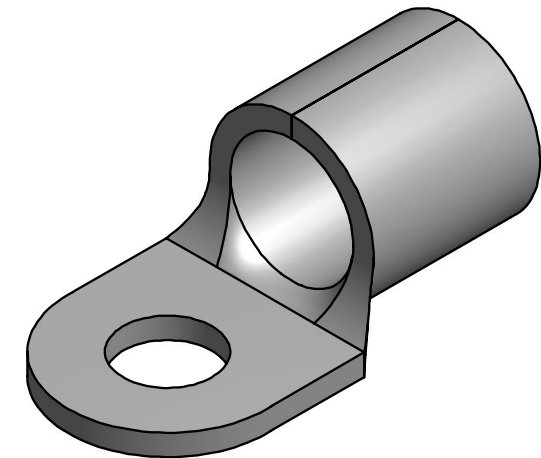
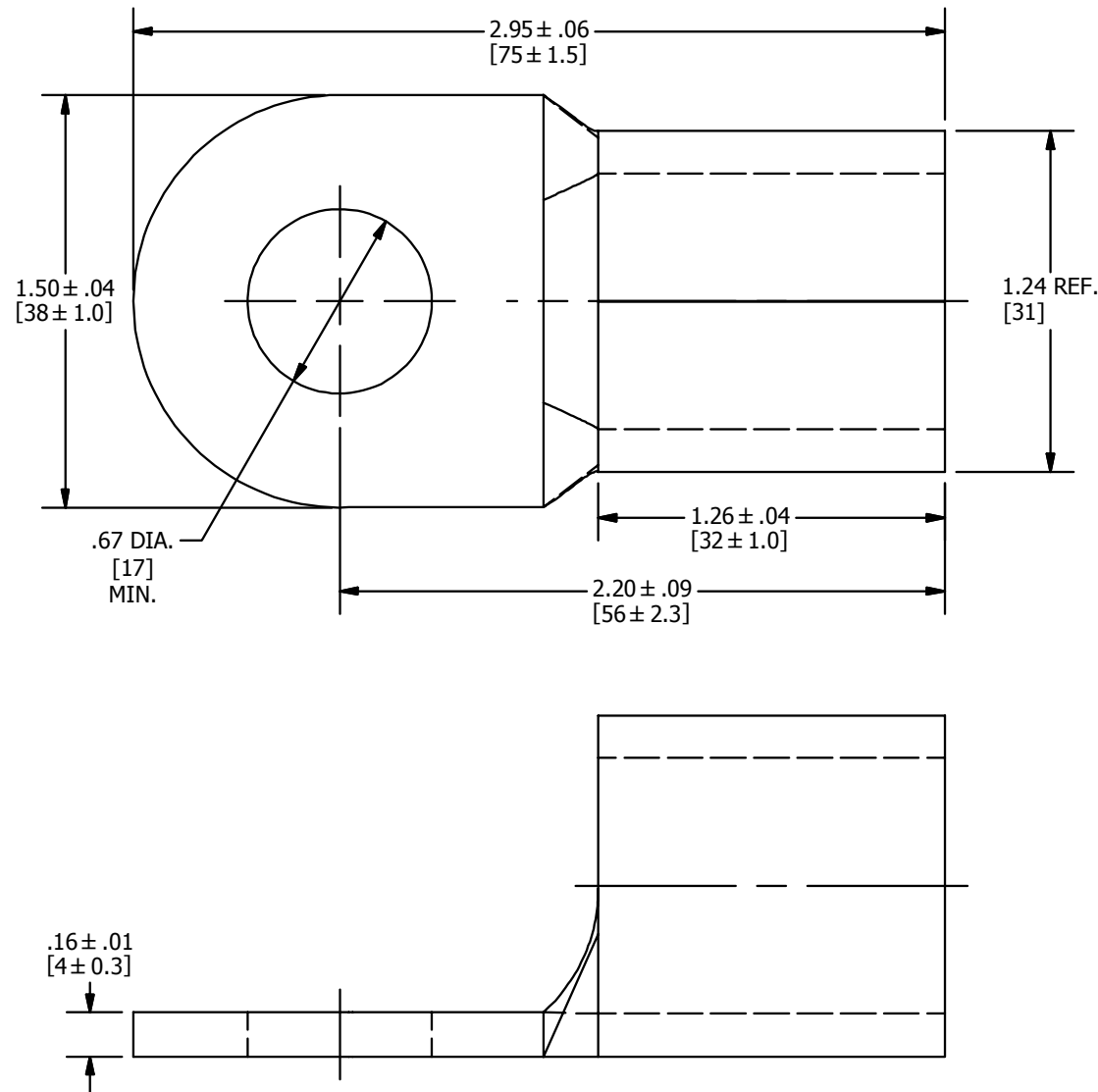

NOTES:

1. MATERIAL: COPPER.
2. FINISH: TIN PLATED.
3. DIMENSIONS IN BRACKETS [ ] ARE IN MILLIMETERS ROUNDED OFF TO THE NEAREST MILLIMETER, UNLESS OTHERWISE NOTED, AND ARE FOR REFERENCE ONLY.

4 USE 2 CRIMPS FOR DIELESS TOOLING.

TO ORDER BURNDY PRODUCTS CALL		NON-INSULATED BRAZED BARREL COPPER TERMINAL	
UNITED STATES		ITEM NO: 50002440	
1-800-346-4175 (LONDONDERRY, NH)		CAT. NO: YAD33M16E58	
CANADA:		DRAWN BY: V KAMAL 10/30/2012	
1-800-361-6975 (QUEBEC)		CHECKER: J MICHAUD 11/27/2012	
1-800-387-6487 (ALL OTHER PROVINCES)		DSN APRVL: J MICHAUD 11/27/12	
FOR PRODUCT INFO: <a href="http://www.burndy.com">http://www.burndy.com</a>		MFG APRVL: --	
		QA APRVL: C KOWALCZYK 11/29/12	
		MKT APRVL: S GALE 11/21/12	
PROJECT #:	SIZE	DRAWING NO	REV
DOCUMENT TYPE: Sales	B	50013875	B
REL LEVEL: Released		SHEET 1 OF 1	