

Carlon® Carflex® Liquidtight Flexible Tubing

Carflex®
Carflex® X-Flex™
Fittings
Cord Grips
Pre-Wired Whips

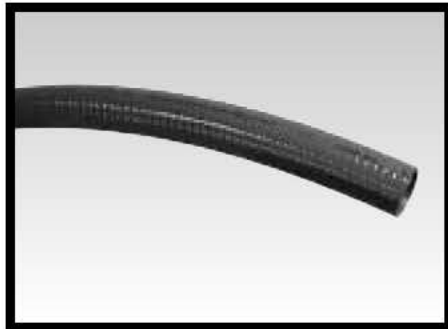

Carflex® Liquidtight Flexible Conduit



Carflex Liquidtight Flexible Nonmetallic Conduit provides superior wire protection in harsh, damp environments. Carflex Conduit is nonconductive, noncorrosive, and resistant to oil, acid, ozone, and alkaline. Carflex Conduit is strong and lightweight, and because it weighs 50% less than metallic systems, it's easy to handle, transport and install. Carflex is ideal for industrial, air conditioning, heating, and outdoor lighting applications.

Features

- Nonconductive and noncorrosive
- Lightweight for easy handling, transportation, and installation
- Crush, abrasion, and strain resistant
- Provides superior wire protection
- Smooth interior ideal for pulling cable
- No jagged edges
- Maintains internal I.D. even in tight radius bends
- Type LFNC-B
- Resistant to oil, acid, ozone, and alkaline
- UL Listed for use as indicated in Article 356 of the 2002 NEC; and Section 12-1300 of the 2002 Canadian Electrical Code, Part 1.
- UL Listed for outdoor use
- UL Listed for sunlight resistant
- Trade sizes 1/2", 3/4", and 1" are UL Listed for direct bury

- Sequentially marked footage
- Suitable for use at conduit temperatures of 80°C dry, 60°C wet and 60°C oil resistant as required by section 15-6 of ANSI/NFPA 79-1985 and UL 1660.

Note: Liquidtight flexible conduits, metallic and non-metallic, in contrast to rigid PVC conduit and electrical nonmetallic tubing, does not have wire temperature limitations. Any temperature rated wire (for example, 90° wire) can be used as long as the temperature conditions marked on the conduit are not exceeded. UL Listed conduits that are not marked are limited to a maximum temperature of 60°C wet or dry.

Applications

- Control and motor
- Air conditioning and heating
- Computer power distribution
- Machine tools
- Console wiring
- Transformer connections
- Outdoor lighting

Custom Orders

- Available in black and gray. Consult factory for custom colors.
- Custom cut lengths available; consult factory for details.

Coils

Part No.	Nom. Size (in.)	Std. Ctn. Qty. (ft.)	Std. Ctn. Wt. (lbs.)
15004-100	3/8"	100	11.70
15005-50	1/2"	50	6.50
15005-100*	1/2"	100	13.00
15005BK-100*	1/2"	100	13.00
15007-100*	3/4"	100	18.00
15008-100*	1"	100	28.00
15009-100	1-1/4"	100	37.60
15010-50	1-1/2"	50	22.55
15010-100	1-1/2"	100	47.80
15011-050	2"	50	34.10

Standard color Grey

Reels

Part No.	Nom. Size (in.)	Std. Ctn. Qty. (ft.)	Std. Ctn. Wt. (lbs.)
15004-001	3/8"	1000	145.0
15005-001	1/2"	1000	157.0
15005BK-001	1/2"	1000	157.0
15007-001	3/4"	1000	212.0
15008-500	1"	500	155.0
15009-200	1-1/4"	200	100.0
15010-150	1-1/2"	150	95.7
15011-100	2"	100	94.6

Standard color Grey



LISTED
E79553

*Joint listed UL/CSA
Approved product
available



Carflex X-Flex Extra Flexible Nonmetallic Conduit is ideal for applications requiring extra strength and flexibility such as robotics, and repetitive flexing arms. Carflex X-Flex is nonconductive, noncorrosive, and resistant to oil, acid, ozone, and alkaline. It's designed for use with standard Carflex fittings providing a complete nonmetallic system. Carflex X-Flex is lightweight for easier handling, transportation, and installation.

Features

- Extra strong and flexible to withstand repetitive motions
- Nonconductive and noncorrosive
- Resistant to oil, acid, ozone, and alkaline
- Lightweight for easy handling, transportation, and installation
- Crush, abrasion, and strain resistant
- Provides superior wire protection
- Smooth interior ideal for pulling cable
- No jagged edges
- Rated for continuous use at 60°C (140°F) ambient

Applications

- Repetitive Flexing Arms
- Robotics
- Machine Tools
- Automatic/Moving Machinery
- Control and motor

Specifications

Coils (Available in Black only)

Part No.	Nom. Size (in.)	Std. Ctn. Qty.	Std. Ctn. Wt. (lbs.)
*15104-100	3/8"	100	9.09
◆*15105-100	1/2"	100	10.01
◆*15107-100	3/4"	100	13.91
◆*15108-100	1"	100	18.25
*15109-100	1-1/4"	100	27.65
*15110-100	1-1/2"	100	38.00
*15111-050	2"	50	24.22



E80040

Where noted by *



LR88170

Where noted by ◆

Straight Fittings

- For use with Carflex® conduit and Carflex® X-Flex™ conduit

Image 1



Assembly

Image 2



Compression Nut

Fitting Body

Extended Threads

Nitrile Rubber O-Ring

Metal Locknut

Image 3



Assembly

Image 4



Compression Nut

Sealing Ring

Ferrule

Fitting Body

O Ring

Plastic Locknut

Features

- Nonconductive and Noncorrosive
- Resistant to oil, acid, ozone, and alkaline
- Easy to install
- Nitrile rubber "O" ring for a liquidtight termination
- Temperatures up to 225°F (107°C)
- Meets UL Standard 514B

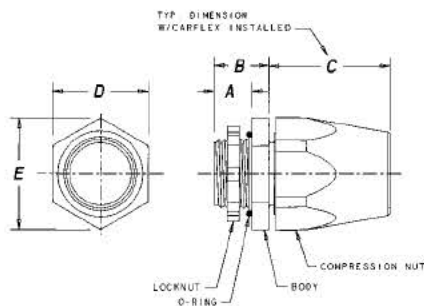

LT43C-CAR, LT43D-NEW, LT43E-NEW, LT43F

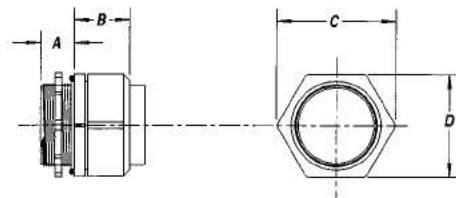

LT43G, LT43H

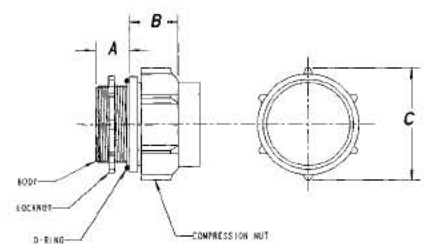

LT43J

Specifications



Part No.	Size (in.)	Std. Ctn. Qty.	Std. Ctn. Wt. (lbs.)	A (inches)	B (inches)	C (inches)	D (inches)	E (inches)	Refer to Image
LT43C	3/8	50	3.6	.55	.75	1.60	1.30	1.40	1, 2
LT43C-CAR	3/8	15	1.4	.55	.75	1.60	1.30	1.40	1, 2
LT43D-NEW	1/2	50	4.2	.56	.91	1.62	1.30	1.40	1, 2
LT43E-NEW	3/4	50	6.6	.56	.91	1.88	1.61	1.71	1, 2
LT43F	1	25	5.5	.70	1.00	2.20	1.90	2.04	1, 2
LT43G	1-1/4	5	1.5	.71	1.16	2.50	2.17		3, 4
LT43H	1-1/2	5	2.0	.75	1.36	2.78	2.43		3, 4
LT43J	2	5	2.5	1.00	1.45	3.33			3, 4

90° Fittings

- For use with Carflex® conduit and Carflex® X-Flex™ conduit

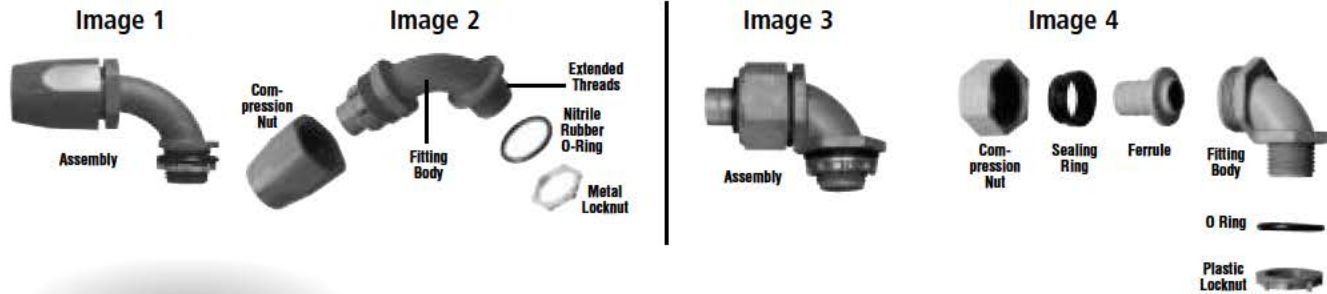

Features

- Nonconductive and Noncorrosive
- Resistant to oil, acid, ozone, and alkaline
- Easy to install
- Nitrile rubber "O" ring for a liquidtight termination
- Temperatures up to 225°F (107°C)
- Meets UL Standard 514B

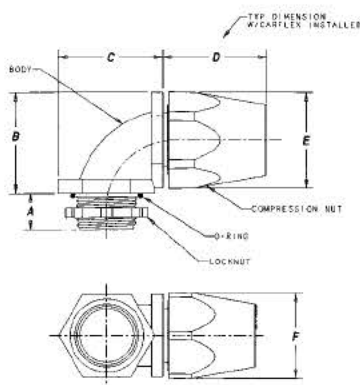

LT20C-CAR, LT20F-NEW

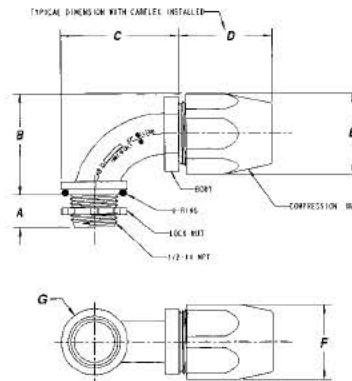

LT20D-NEW, LT20E-NEW

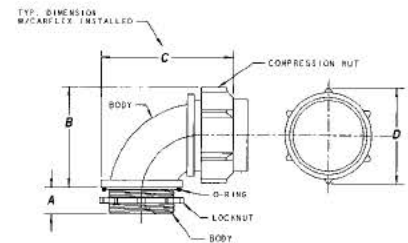

LT20G, LT20H, LT20J

Specifications



Part No.	Size (in.)	Std. Ctn. Qty.	Std. Ctn. Wt. (lbs.)	A (inches)	B (inches)	C (inches)	D (inches)	E (inches)	F (inches)	G (inches)	Refer to Image
LT20C	3/8	50	4.9	.56	1.44	1.44	1.56	1.39	1.26		3, 4
LT20C-CAR	3/8	15	1.8	.56	1.44	1.44	1.56	1.39	1.26		3, 4
LT20D-NEW	1/2	50	4.9	.56	1.76	2.05	1.62	1.40	1.30	1.15	1, 2
LT20E-NEW	3/4	50	8.0	.56	2.04	2.35	1.88	1.71	1.61	1.50	1, 2
LT20F	1	25	6.9	.70	2.01	2.01	2.26	2.04	1.90		3, 4
LT20G	1-1/4	5	1.9	.75	2.50	3.55	2.48				3, 4
LT20H	1-1/2	5	2.2	.75	2.80	3.98	2.77				3, 4
LT20J	2	5	3.4	.94	3.48	4.56	3.33				3, 4

Carflex® One-Piece Liquidtight Fittings



Unique Design

The simple, one piece body design of the Carflex One Piece Liquidtight Nonmetallic Fitting requires no disassembly of components for installation. The system is so strong that there is no need for a compression nut.

PVC Construction

PVC construction of the fitting and locknut provides unparalleled protection from water, oil and dust. Totally nonmetallic, the system is nonconductive and will not corrode or rust. Temperatures up to 140°F (60°C)

Straight Fittings

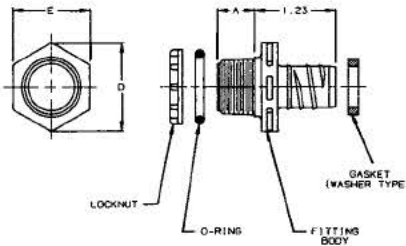

Part No.	Trade Size (in.)	Std. Ctn. Qty.	Std. Ctn. Wt. (lbs.)	A (inches)	D (inches)	E (inches)
LN43DA	1/2 - 14 NPT	100	2.8	0.56	1.34	1.19
LN43EA	3/4 - 14 NPT	50	2.2	0.56	1.63	1.44
LN43FA	1 - 11 1/2 NPT	25	3	0.69	1.99	1.75
LN43FA-CAR	1 - 11 1/2 NPT	15	1	0.69	1.99	1.75

90° Fittings

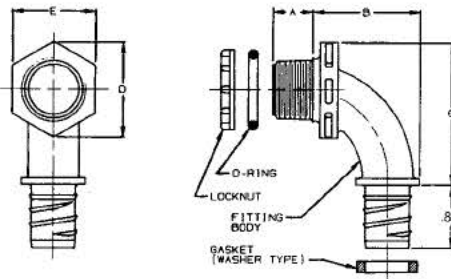

Part No.	Trade Size (in.)	Std. Ctn. Qty.	Std. Ctn. Wt. (lbs.)	Thread Size	A (inches)	B (inches)	C (inches)	D (inches)	E (inches)
LN20DA	1/2 - 14 NPT	100	4.3	1/2-14 NPT	0.56	1.50	1.99	1.34	1.19
LN20EA	3/4 - 14 NPT	50	3.1	3/4-14 NPT	0.56	1.73	2.25	1.63	1.44
LN20FA	1 - 11 1/2 NPT	25	3.2	1-11 1/2 NPT	0.69	1.86	2.58	1.99	1.75
LN20FA-CAR	1 - 11 1/2 NPT	10	1	1-11 1/2 NPT	0.69	1.86	2.58	1.99	1.75



Straight



Features

- Available in sizes 3/8" through 1" conduit and tubing.
- All nylon construction resists salt water, weak acids, gasoline, alcohol, oil, grease and common solvents.
- No disassembly required.
- No threading of the conduit or tubing required to install.
- Complete Conduit/connector system is reusable.
- Suitable for indoor/outdoor use.
- Lower installed cost.
- Black connectors provided with nylon locknut.
- Gray connectors provided with assembled O-ring and metal locknuts.
- Protection class IP 68 per DIN 40050 up to 70 psi (5 bar) water pressure.
- Molded of type 6/6 nylon. ASTM D-4066-PA 111; flammability classification 94V-2.

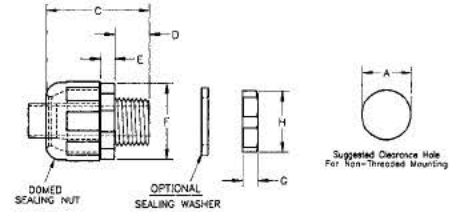

Specifications

Size	Part No. Black	Part No. Gray*	Description	Body & Sealing Unit					Locking Nut		Std. Ctn. Qty.
				A	C	D	E	F	G	H	
				Clearance Hole in. (mm)	Max O.A. Length in. (mm)	Thread Length in. (mm)	Wrenching Nut Thickness in. (mm)	Wrenching Flats in. (mm)	Thickness in. (mm)	Wrenching Flats in. (mm)	
3/8"	LT38	LT38G	Straight L/T Fitting	.875 (22.2)	2.000 (50.8)	.625 (15.9)	.250 (6.3)	1.328 (33.7)	.266 (6.7)	1.062 (26.9)	50
1/2"	LT50	LT50G	Straight L/T Fitting	.875 (22.2)	2.000 (50.8)	.625 (15.9)	.250 (6.3)	1.328 (33.7)	.266 (6.7)	1.062 (26.9)	50
3/4"	LT75	LT75G	Straight L/T Fitting	1.109 (28.2)	2.031 (51.6)	.625 (15.9)	.250 (6.3)	1.562 (39.7)	.266 (6.7)	1.312 (33.3)	25
1"	LT100	LT100G	Straight L/T Fitting	1.375 (34.9)	2.250 (57.1)	.781 (19.8)	.250 (6.3)	1.875 (47.6)	.266 (6.7)	1.625 (41.3)	20

*Gray connectors provided with assembled o-ring and metal locknuts. Black connectors provided with nylon locknuts only.

90°



Features

- Available in sizes 3/8" through 1" conduit and tubing.
- Smooth internal surfaces for easier wire installation around corner angles.
- All nylon construction resists salt water, weak acids, gasoline, alcohol, oil, grease and common solvents.
- No disassembly required.
- No threading of the conduit or tubing required to install.
- Complete conduit/connector system is reusable.
- Use of a sealing washer may be required for wet locations.
- Suitable for indoor/outdoor use.
- Lower installed cost.
- Black connectors provided with nylon locknut, packed separately.
- Gray connectors provided with assembled O-ring and metal locknuts.
- Protection class IP 68 per DIN 40050 up to 70 psi (5 bar) water pressure.
- Molded of type 6/6 nylon. ASTM D-4066-PA 111; flammability classification 94V-2.

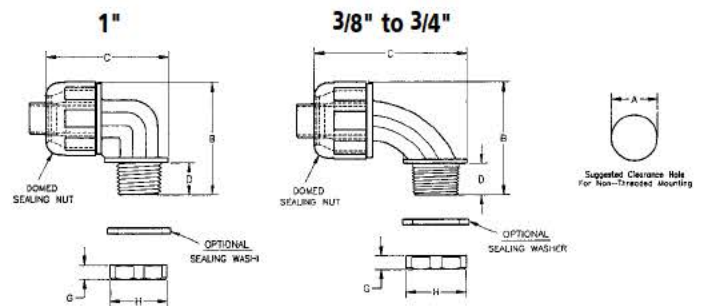

Specifications

Size	Part No. Black	Part No. Gray	Description	Body & Sealing Unit				Locking Nut		Std. Carton Qty.
				A	B	C	D	G	H	
				Clearance Hole in. (mm)	Max O.A. Height in. (mm)	Max O.A. Length in. (mm)	Thread Length in. (mm)	Thickness in. (mm)	Wrenching Flats in. (mm)	
3/8"	LT938	LT938G	90 degree L/T Fitting	.875 (22.2)	1.98 (50.3)	2.91 (73.9)	.52 (13.2)	.27 (6.8)	1.06 (26.9)	25
1/2"	LT950	LT950G	90 degree L/T Fitting	.875 (22.2)	1.98 (50.3)	2.91 (73.9)	.52 (13.2)	.27 (6.8)	1.06 (26.9)	25
3/4"	LT975	LT975G	90 degree L/T Fitting	1.109 (28.2)	2.29 (58.2)	3.17 (80.5)	.52 (13.2)	.27 (6.8)	1.31 (33.3)	20
1"	LT9100	LT9100G	90 degree L/T Fitting	1.375 (34.9)	2.84 (72.1)	3.18 (80.8)	.78 (19.8)	.27 (6.8)	1.61 (40.9)	10

Carflex Fittings Installation Instructions

LT43C-CAR, LT43F thru J, LT20C-CAR, LT20F thru J.

1. Cut the end of the Carflex conduit or Carflex® X-Flex™ tubing square.
2. Install compression nut and sealing gland ring over the end of the conduit or tubing.
3. Insert the ferrule end of the fitting into the conduit using a clockwise twisting action.
4. Screw fitting body into compression nut.
5. When installation is completed, use a wrench, tighten compression nut one-quarter (1/4) turn past hand-tight. Do not over tighten fitting.

*To prevent damage to conductors, conduit and fittings, do not twist Carflex during installation.

LT43D-New, LT43E-New, LT20D-New, LT20E-New.

1. Cut the end of the Carflex conduit or Carflex® X-Flex™ tubing square.
2. Install compression nut over the end of the conduit or tubing.
3. Insert the ferrule end of the fitting into the conduit using a clockwise twisting action. (Be sure conduit is fully inserted to the bottom of the fitting shoulder).
4. Screw compression nut onto fitting body.
5. Use a wrench, and tighten compression nut one (1) full turn past hand-tight. Do not over tighten fitting.

*To prevent damage to conductors, conduit and fittings, do not twist Carflex during installation.

Carflex Liquidtight Conduit Technical Information

1. There shall be no more than the equivalent of four (4) quarter (90°) bends (360° total) between pull points, conduit bodies, and boxes.
2. The radius of the curve of the center of the conduit or tubing shall not be less than that shown in the table below:

SIZE OF CONDUIT OR TUBING		RADIUS TO CENTER OF CONDUIT OR TUBING	
Inches	Metric Desgr.	Inches	(mm)
3/8	(14)	4	(101.6)
1/2	(16)	4	(101.6)
3/4	(21)	4 1/2	(114.3)
1	(27)	5 3/4	(146.0)
1 1/4	(35)	7 1/4	(184.1)
1 1/2	(41)	8 1/4	(209.5)
2	(53)	9 1/2	(241.3)

UL Listed for use as indicated in Article 356 of the National Electrical Code

- Cellular Metal Floor Raceways, Connections to Cabinets & Wall Outlets
- Class I, Div. 2, Hazardous Location
- Class II, Div. 1, Hazardous Location
- Class III, Div. 1, Hazardous Location
- Computer Room Raised Floor
- Concealed Locations
- Intrinsically Safe Systems
- Lighting Fixtures, Connection to Electric Discharge Fixture
- Nonmetallic Boxes
- RV Engine Generator
- Swimming Pool Pump Motor
- Tap Conductors (Fixture Whips)
- Underfloor Raceway, Connection to Cabinets & Wall Outlets
- Wireway, Extensions from Wireways, Wiring Methods
 - Agricultural Buildings, Flexible Connections
 - Electric Signs, 1000 Volts, Nominal, or Less
 - Electric Signs, Over 1000 Volts (per Section 600.32(A)(1))
 - Floating Buildings
 - Marinas and Boatyards
 - Service Entrance Conductors
- Wiring on Buildings, Outside Branch Circuits & Feeders



Carflex® Liquidtight Whip assemblies save the customer time and hassle of having to hunt for the needed components. Our moisture tight, nonmetallic, flexible conduit system is ideal for installing swimming pool motors, hot tubs, spas, air conditioners, pumps, outdoor lighting and more.

Unlike plastic coated metal conduit, the Carlon® Carflex system has no metal core to fatigue, rust, or corrode. The Carflex system has no sharp edges or burrs to cut into the wire insulation. Metal conduit is subject to fatigue and penetration of moisture.

The Carflex Liquidtight Whip assembly is complete with Carflex moisture tight conduit, wire, one straight fitting, and one 90° fitting.

All this makes for quick and trouble free installation.



Features

- Designed for easy installation
- Will not rust or corrode
- Can be used for many commercial and residential applications.
- Many applications such as; swimming pool filters, hot tub spas, air conditioners, pumps, etc.
- Available in 1/2" and 3/4" diameters
- Available in 4' and 6' lengths
- Each kit contains (1) straight and (1) 90° fitting
- Complete with (3) 8, 10 or 12 gauge wires

Custom Orders

Also available in special configurations including different fitting combinations, wire types and sizes, and metal fitting variations. Consult factory for details.

Specifications

Part Number	Description	Wire Size (Gauge)	Standard Carton Quantity	Standard Carton Weight (lbs.)
WCD4	1/2" Carflex Whip - 4 foot	10	6 (poly bag)	10.6
WCD6	1/2" Carflex Whip - 6 foot	10	6 (poly bag)	15.8
WCE4	3/4" Carflex Whip - 4 foot	8	6 (poly bag)	12.4
WCE6	3/4" Carflex Whip - 6 foot	8	6 (poly bag)	15.8

Part Number	Description	Wire Size (Gauge)	Standard Carton Quantity	Standard Carton Weight (lbs.)
WCD3124	1/2" Carflex Whip - 4 foot	12	20 (bulk pack)	32.4
WCD3126	1/2" Carflex Whip - 6 foot	12	20 (bulk pack)	47.9
WCD3104	1/2" Carflex Whip - 4 foot	10	20 (bulk pack)	35.2
WCD3106	1/2" Carflex Whip - 6 foot	10	20 (bulk pack)	52.8
WCE3084	3/4" Carflex Whip - 4 foot	8	15 (bulk pack)	30.9
WCE3086	3/4" Carflex Whip - 6 foot	8	15 (bulk pack)	39.6

Straight PG Hubs



Features

- New threads on body prevent skipping, speed installation.
- PG hub threads are steel conduit per DIN 40430.
- Six sizes for cable, tubing, etc.: PG07, PG09, PG11, PG13.5, PG16, and PG21.
- All nylon construction with TPE gland resists salt water, weak acids, gasoline, alcohol, oil, grease and common solvents.
- Suitable for NEMA type 4 and 6 enclosures.
- Locknuts are included.
- Working temperatures: -22°F (-30°C) to 212°F (100°C). For short periods to 302°F (150°C).
- Protection Class IP68 per DIN 40050 up to 70 psi (5 Bar) water pressure.

Specifications

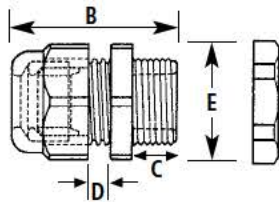

Suggested Clearance Hole For Nonthreaded Mounting



Patented 4,900,068

Size (PG)	Straight Part No. Black	Std. Ctn. Qty.	Std. Ctn. Wt.	Diameter of Cable or Wire Accommodated in. (mm)	A	B	C	D	E
					Clearance Hole in. (mm)	Max O.A. Length in. (mm)	Thread Length in. (mm)	Wrenching Nut Thickness in. (mm)	Wrenching Flats in. (mm)
PG07	LH07	100	1.3	.114-.250 (2.9-6.4)	.492 (12.5)	1.17 (29.7)	.33 (8.4)	.22 (5.6)	.59 (15.0)
PG09	LH09	100	2.0	.181-.312 (4.6-7.9)	.599 (15.2)	1.30 (33.0)	.34 (8.6)	.20 (5.1)	.75 (19.1)
PG11	LH11	100	2.6	.230-.395 (5.8-10.0)	.733 (18.6)	1.46 (37.1)	.39 (9.9)	.20 (5.1)	.86 (21.8)
PG13.5	LH13	100	3.1	.170-.470 (4.3-11.9)	.804 (20.4)	1.53 (38.9)	.41 (10.4)	.20 (5.1)	.95 (24.1)
PG16	LH16	50	2.1	.230-.546 (5.8-13.9)	.886 (22.5)	1.66 (42.2)	.45 (11.4)	.23 (5.8)	1.05 (26.7)
PG21	LH21	50	3.2	.450-.709 (11.4-18.0)	1.115 (28.3)	1.87 (47.5)	.52 (13.2)	.23 (5.8)	1.30 (33.0)

Carlon® recommends using the smallest maximum diameter fitting that will suit your application.

Straight NPT Hubs



Features

- New threads on body prevent skipping, speed installation.
- Four sizes for cable, tubing, etc. with diameters of 3/8", 1/2", 3/4" and 1".
- All nylon construction with TPE gland resists salt water, weak acids, gasoline, alcohol, oil, grease and common solvents.
- Suitable for NEMA type 4 and 6 enclosures.
- Locknuts are included.
- Working temperatures: -22°F (-30°C) to 212°F (100°C). For short periods to 302°F (150°C).
- Protection Class IP68 per DIN 40050 up to 70 psi (5 Bar) water pressure.

Specifications

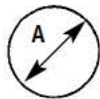
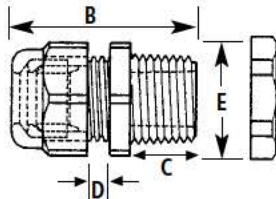

Suggested
Clearance Hole
For Nonthreaded
Mounting



Patented 4,900,068

Size (NPT)	Straight Part No. Black	Straight Part No. Gray	Std. Ctn. Qty.	Std. Ctn. Wt.	Diameter of Cable or Wire Accommodated in. (mm)	A	B	C	D	E
						Clearance Hole in. (mm)	Max O.A. Length in. (mm)	Thread Length in. (mm)	Wrenching Nut Thickness in. (mm)	Wrenching Flats in. (mm)
3/8"	LH38	LH38G	100	1.9	.181-.312 (4.6-7.9)	.670 (17.0)	1.49 (37.8)	.53 (13.5)	.20 (5.1)	.75 (19.1)
1/2"	LH50	LH50G	100	2.9	.170-.470 (4.3-11.9)	.875 (22.2)	1.72 (43.7)	.62 (15.7)	.20 (5.1)	.95 (24.1)
3/4"	LH75	LH75G	50	2.7	.450-.709 (11.4-18.0)	1.068 (27.1)	1.97 (50.0)	.63 (16.0)	.23 (5.8)	1.30 (33.0)
1"	LH100	LH100G	25	2.6	.590-1.000 (15.0-25.4)	1.375 (35.0)	2.42 (61.5)	.78 (19.8)	.28 (7.1)	1.66 (42.2)

Carlon® recommends using the smallest maximum diameter fitting that will suit your application.