

SNH & NH 1" Wide



STRIP AND RING

- Two Terminals, One End (type SNH)
- One Terminal, Each End (type NH)
- 8 - 53-7/8" Lengths
- 250 - 1,500 Watts
- 120 and 240 Volt
- 7 - 24 W/In²



Dimensions (type NH)

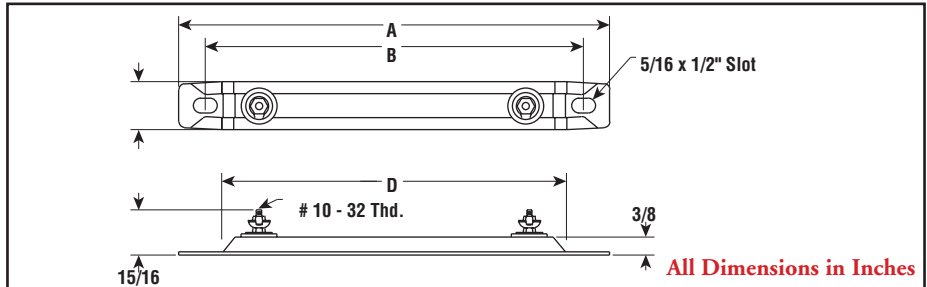

Dimensions (type SNH)

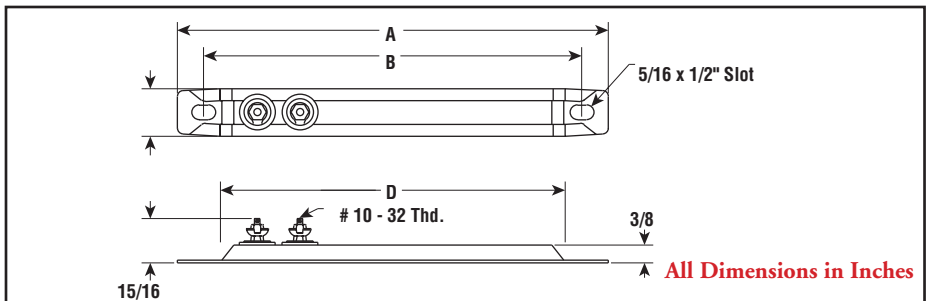

Applications

Strip heaters are used for heat transfer by conduction or convection to heat liquids, air, gases and surfaces. See guidelines in the Strip Heater Overview section.

Specifications and Ordering Information

Dimensions (In.)			Watts	W/In ²	Chrome Steel Sheath				Chrome Steel Sheath				Wt. (Lbs.)		
A	B	D			Model	120V		240V		Model	120V			240V	
					Stock	PCN	Stock	PCN		Stock	PCN	Stock	PCN		
8	7	6-1/2	250	24	SNH-08	S	133727	—	—	NH-08	NS	133209	—	—	0.4
9-1/2	8-1/2	8	300	21	SNH-09	S	133735	—	—	NH-09	NS	133217	—	—	0.4
11	10	9-1/2	350	19	SNH-11	S	133743	—	—	NH-11	NS	133225	—	—	0.5
12	11	10-1/2	400	19	SNH-12	S	133751	S	133760	NH-12	NS	133233	—	—	0.6
14	13	12-1/2	450	17	SNH-14	S	133778	S	133786	NS-14	NS	133241	—	—	0.7
15-1/4	14-1/4	13-3/4	500	17	SNH-15	S	133794	S	133807	NH-15	NS	133250	NS	133268	0.8
17-7/8	16-7/8	16-3/8	600	17	SNH-18	S	133815	S	133823	NH-18	NS	133276	NS	133284	0.9
19-1/2	18-1/2	18	600	15	SNH-19	NS	133831	S	133840	—	—	—	—	—	1
19-1/2	18-1/2	18	700	17	—	—	—	—	—	NH-19	NS	133292	NS	133305	1
21	20	19-1/2	750	17	SNH-21	NS	133858	S	133866	NH-21	NS	133313	NS	133321	1
22-1/2	21-1/2	21	750	16	SNH-22	NS	133874	S	133882	—	—	—	—	—	1
23-3/4	22-3/4	22-1/4	300	7	—	—	—	—	—	NH-24	NS	133330	NS	133348	1
23-3/4	22-3/4	22-1/4	800	16	SNH-24	NS	133890	S	133903	—	—	—	—	—	1
25-1/2	24-1/2	24	900	16	SNH-25	NS	133911	NS	133920	—	—	—	—	—	1.1
27-1/2	26-1/2	26	900	14	SNH-27	NS	133938	NS	133946	—	—	—	—	—	1.1
28-3/4	27-3/4	27-1/4	1,000	16	SNH-28	NS	133954	S	133962	—	—	—	—	—	1.3
30-1/2	29-3/8	28	1,000	15	SNH-30	S	133970	S	133989	—	—	—	—	—	1.3
33-1/2	32-3/8	31	1,000	14	SNH-33	NS	133997	S	134009	—	—	—	—	—	1.4
35-7/8	34-3/4	33-3/8	1,000	13	SNH-36	NS	134017	S	134025	—	—	—	—	—	1.5
38-1/2	37-3/8	36	1,250	15	SNH-38	NS	134033	NS	134041	—	—	—	—	—	1.6
39-7/8	38-3/4	37-3/8	1,250	14	SNH-40	NS	134050	S	134068	—	—	—	—	—	1.6
42-1/2	41-3/8	40	1,250	13	SNH-43	NS	134076	NS	134084	—	—	—	—	—	1.8
43-7/8	42-3/4	41-3/8	1,250	13	SNH-44	NS	134092	NS	134105	—	—	—	—	—	1.8
45-7/8	44-3/4	43-3/8	1,500	14	SNH-46	NS	134113	S	134121	—	—	—	—	—	1.9
47-7/8	46-3/4	45-3/8	1,500	14	SNH-48	NS	134130	NS	134148	—	—	—	—	—	2
50-7/8	49-3/4	48-3/8	1,500	13	SNH-51	NS	134156	NS	134164	—	—	—	—	—	2.1
53-7/8	52-3/4	51-3/8	1,500	12	SNH-54	NS	134172	NS	134180	—	—	—	—	—	2.3

Stock Status: S = stock NS = non-stock
To Order—Specify model, PCN, watts, volts and quantity.