

Circulation Heaters

Terminal Enclosures

- E1 General Purpose
- E2 Moisture Resistant/Explosion Resistant
- E4 Moisture Resistant
- Conduit Openings Matched to the Number of Circuits

Applications

The versatility of electric heaters permits them to be used in almost any conceivable location indoors or outdoors, exposed to the weather. Chromalox provides a variety of electrical terminal enclosures to match the unique requirements of virtually any environment.

Features

E1 General Purpose Enclosure — Suitable for most indoor or protected commercial and industrial applications.

E2 Combination Moisture Resistant and Explosion Proof Enclosures — Type E2 explosion proof terminal enclosures are intended for use in hazardous locations. Refer to the following table for details.

Type E2 terminal enclosures are provided with gaskets and are suitable for outdoor or wet locations as well as hazardous areas.

E4 Moisture Resistant Enclosure — Suitable for outdoor or wet locations. The terminal covers are provided with water-tight gaskets to seal the electrical terminals and connections from the environment.

Special Requirements for Electric Heaters & Terminal Enclosures in Hazardous Locations:

Wiring — The proper use of Type E2 terminal enclosures on electric heaters located in hazardous areas requires that all electrical wiring comply with National Electrical Code (NEC) and IEC requirements for hazardous locations.

Maximum Temperatures — Safe operation in a hazardous location requires the maximum operating temperatures of all exposed surfaces of the heater including temperatures on the outside of the vessel, piping, flanges, screw plugs, enclosures and other heat conducting parts be limited. The maximum surface temperature permitted in any hazardous location is determined by the flammable liquids, vapors or gases present. The end user or purchaser of the electric heating equipment is responsible for determining the proper classification of an area and for providing Chromalox with hazardous area specifications and requirements for proper equipment design. (NEC Articles 500 and 501 provide guidelines for evaluating and classifying hazardous locations.)

Safety Devices — Approved pressure and/or temperature limiting controls must be used on electric heaters and heating elements to ensure safe operation in the event of system malfunctions.

Note 1 — Class I Group B locations include Hydrogen gas. These areas require additional conduit seals and thread engagement. Contact your Local Chromalox Sales office for heaters and terminal enclosures suitable for Class I Group B hazardous locations.

Typical Terminal Enclosures

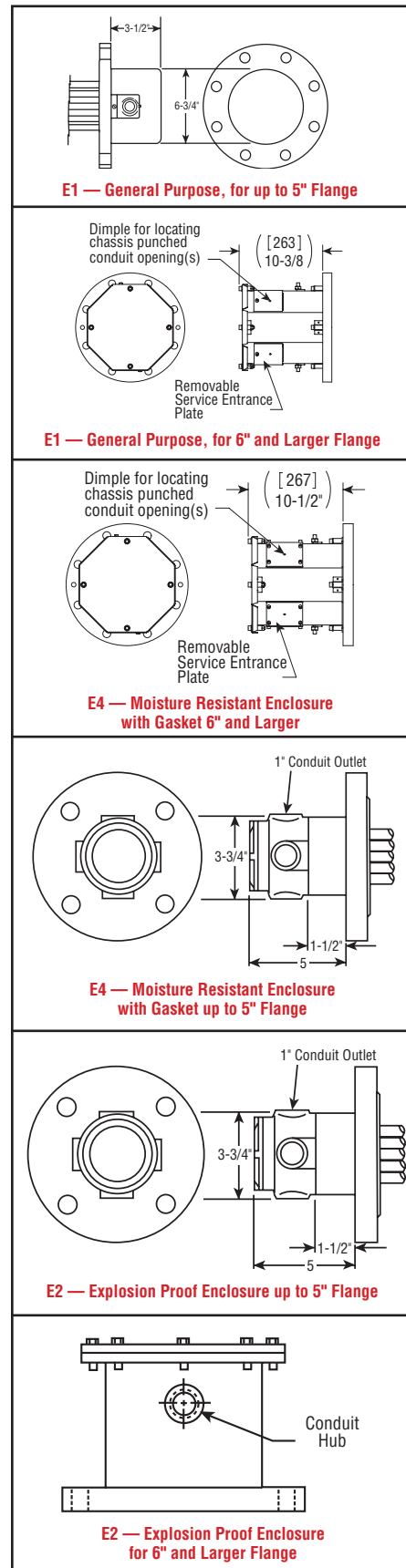

Circulation Heaters

Terminal Enclosures

Third Party Specifications by Housing Style

Model	Purpose		North American Designation(s)	Canadian Designation(s)	European Designation(s)	International Designation(s)
E1	General Purpose	Generic Agency (s)	NEMA 1, NEC UL/CSAus	NEMA 1 IP32 CSA	IP32 CE: Manufacturer's Declaration	CE: Manufacturer's Declaration
		Ratings	General Duty Only	General Duty Only	General Duty Only	General Duty Only
E4*	Moisture Resistant Note: Temps over T3 (200°C) require stand-offs for third party listing. Refer to IECex & ATEX certifs. for standoff dimensions	Generic Agency (s)	NEMA 4 UL / CSAus	NEMA 4 CSA	IP66 CE: Manufacturer's Declaration	IP66 CE: Manufacturer's Declaration
		Ratings	Class I Div. 2, Groups B, C, D Groups E, F: 200°C (T3) Group G 165°C (T3B) Class I Zone 2 AEx nA II T1 to T6	Class I Div. 2, Groups B, C, D Class II Division 2, Groups E, F: 200°C (T3) Group G 165°C (T3B) Class I Zone 2 Ex nA II T1 to T6	II 3 G Ex nA II T1 to T6	Ex nA II T1 to T6
E2	Moisture Resistant/ Explosion Proof Ex d IIB+H2 T1 to T6 Note: Temps over T4 (135°C) require stand-offs for third party listing. Refer to IECex & ATEX certifs. for standoff dimensions	Generic Agency (s)	CSAus	CSA	ATEX	IECex
		Ratings	Class I, Div. 1 Groups B,C & D Class II, Div. 1 Groups E, F & G Class I Zone 1 AEx d IIB + H2 T1 to T6	Class I, Div. 1 Groups B,C & D Class II, Div. 1 Groups E, F & G Class I Zone 1 Ex d IIB + H2 T1 to T6	I 2 G EEx d IIB+H2 T1 to T6	Ex d IIB+H2 T1 to T6
E4 Flange Size 3"-8" 8"-12" 12"-18"	Moisture Resistant/ Explosion Proof Ex d IIB+H2 T1 to T6 540°C, 600°C ATEX IIC Labeling Reference CFP4, CFP8, CFP12 Refer to European Catalog	Generic Agency (s)			ITS ATEX	IECex
		Ratings			II 2 G EEx de IIC T1 to T6, 540°C, 600°C	Ex de IIC T1 to T6 540°C, 600°C

* **WARNING:** Addition of sparking devices such as a Thermostat to an E4 housing will annul hazardous area rating.

Circulation Heaters

Terminal Enclosures

*ATEX/IECEX/CSA Zone Classification Selection chart for terminal enclosure
standoff dimension based on 30°C rise over 40°C ambient*

70°C Cable Supply			Vertical Heater Orientation		Horizontal Heater Orientation	
Temperature Code	Wet Face Temperature: °F	Wet Face Temperature: °C	Minimum Standoff Dimension		Minimum Standoff Dimension	
			Inches	mm	Inches	mm
T6	185	85	3	76	1	25
T5	212	100	3	76	2	50
T4A	248	120	5	127	3	76
T4	275	135	6	152	3	76
T3C	320	160	7.5	191	4	102
T3B	329	165	7.5	191	4	102
T3A	356	180	7.5	191	5	127
T3	392	200	9	229	5	127
T2D	419	215	9	229	5	127
T2C	446	230	9	229	6	152
T2B	500	260	10.5	267	6	152
T2A	536	280	10.5	267	6	152
T2	572	300	10.5	267	7.5	191
T1	842	450	13.5	343	9	229

*ATEX/IECEX/CSA Zone Classification Selection chart for terminal enclosure
standoff dimension based on 10°C rise over 60°C ambient*

70°C Cable Supply			Vertical Heater Orientation		Horizontal Heater Orientation	
Temperature Code	Wet Face Temperature: °F	Wet Face Temperature: °C	Minimum Standoff Dimension		Minimum Standoff Dimension	
			Inches	mm	Inches	mm
T6	185	85	9	229	6	152
T5	212	100	10.5	267	7.5	191
T4A	248	120	12	305	7.5	191
T4	275	135	12	305	7.5	191
T3C	320	160	12	305	7.5	191
T3B	329	165	12	305	9	229
T3A	356	180	13.5	343	9	229
T3	392	200	15	381	9	229
T2D	419	215	15	381	10.5	267
T2C	446	230	15	381	10.5	267
T2B	500	260	16.5	419	10.5	267
T2A	536	280	18	457	10.5	267
T2	572	300	18	457	10.5	267
T1	842	450	24	610	12	305

*CSA Class and Division Classification Selection chart for terminal enclosure
standoff dimension based on 85°C rise over 40°C ambient*

125°C Cable Supply			Vertical Heater Orientation		Horizontal Heater Orientation	
Temperature Code	Wet Face Temperature: °F	Wet Face Temperature: °C	Minimum Standoff Dimension		Minimum Standoff Dimension	
			Inches	mm	Inches	mm
T6	185	85	0	0	0	0
T5	212	100	0	0	0	0
T4A	248	120	0	0	0	0
T4	275	135	0	0	0	0
T3C	320	160	2	50	0	0
T3B	329	165	2	50	0	0
T3A	356	180	4	102	2	50
T3	392	200	4	102	2	50
T2D	419	215	4	102	2	50
T2C	446	230	4	102	2	50
T2B	500	260	6	152	4	102
T2A	536	280	6	152	4	102
T2	572	300	6	152	4	102
T1	842	450	7.5	191	6	152