

NT Motor 230 V

Compact NEMA or Metric Flange AC Servo Motors

The NT motor is a compact, high performance brushless AC servo motor designed to maximize torque and minimize size. The NT motor uses powerful magnets and is manufactured with a segmented core to maximize stator efficiency.

These motors are available with direct motor-to-drive connector terminations for Control Techniques' brand Unidrive M, Digitax ST and Epsilon EP servo drives – cable lengths up to 20 ft are available.



Key Features

- Torque range: 7.5 to 56 lb-in (0.85 to 6.3 Nm)
- Very low inertia for high acceleration and cycle rates
- English (NEMA 23 or 34) or Metric (IEC- 72-1) flanges
- Available with or without holding brakes
- Direct connect available – no additional cables required!
- Flying-lead cabling option (ex: NTE-320-LONS-0005) with improved ingress protection; flying leads are available with or without MS connectors
- IP65 conformance (IP67S and IP68S optional)
- Standard 2048 encoder
- Installed shaft seal are standard with all motors
- Optional white epoxy food-grade finish

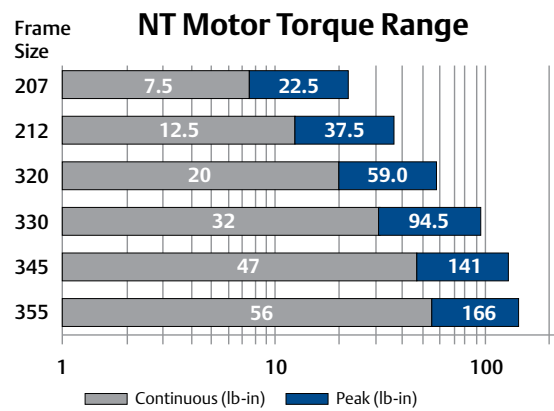

NT MOTORS

NT Motor 230 V Order Information

Use the information below to create an order code for an NT Motor (top row is an example).

NT	E	2	07	T	B	N	S	DP	10
Motor	Mounting Flange	Frame Size (in)	Rated Torque (lb-in)	Lead Configuration	Brake (24 V)	Feedback Device	Inertia	Feedback Cable Connectors / Optional Finish	Cable Length
NT	E = English	2 = 2 [‡]	2-in frame	IP65	O = Unbraked	N = Incremental encoder 2048 ppr	S = Low	Lead Configuration C, L, T, E	Lead Configuration C, L, T, E
	M = Metric	3 = 3 [‡]	07 = 7.5	C = MS connector	B = Holding Brake			00 = Std. configuration	00 = Std. configuration
			12 = 12.5	L = Flying leads (no connectors)				Lead Configuration T	Lead Config L, T And F
			3-in frame	T = MS style connector on flying leads				DP = Flying lead with molded 15-pin feedback connector to Digitax ST, Unidrive SP and Epsilon EP	05 = 5-ft leads
			20 = 20						10 = 10-ft leads
			30 = 32						15 = 15-ft leads
			45 = 47	IP67S				Lead Configurations C, L, T, E, F	20 = 20-ft leads
			55 = 56	E = 90° circular Euro style				E0 = White epoxy food-grade finish applied to standard motor*	XX = Custom lengths available up to 20 ft max. in 2-ft increments
				IP68S					
				F = Flying lead and white epoxy food-grade finish					

*Include this code when ordering "F" type lead configuration

Approvals



NOTES:

[‡]2 = 2-in NEMA 23

[‡]3 = 3-in NEMA 34

NT Motor 2-inch Frame Ratings and Dimensions

Motor Frame Size (in)		2	
Voltage (Vrms)		230	
Model	NT-207	NT-212	
Continuous Stall Torque (lb-in)	7.5	12.5	
Continuous Stall Torque (Nm)	0.85	1.4	
Peak Torque (lb-in)	22.5	37.5	
Peak Torque (Nm)	2.54	4.24	
Inertia (lb-in-sec ²)	0.000094	0.000164	
Inertia (kgm ²)	0.0000106	0.0000185	
Cogging (lb-in) (typ.)	0.094	0.12	
Cogging (Nm) (typ.)	0.011	0.014	
Motor Weight (lbs)	3.0	4.0	
Motor Weight (kg)	1.36	1.81	
Number of Poles	8	8	
5000 rpm	Kt (lb-in/A) =	5.12	5.08
	Kt (Nm/A) =	0.58	0.57
	Ke (V/k rpm) =	35	34.7
Rated Torque (lb-in)	7.50	12.50	
Rated Torque (Nm)	0.85	1.4	
Stall Current (A)	1.7	2.7	
Rated Power (kW)	0.432	0.740	
R (ph-ph) (Ohms)	11.1	4.56	
L (ph-ph) (mH)	39.1	18.9	

NOTES:
 Δt= 212 °F (100 °C) winding 104 °F (40 °C) maximum ambient; all data subject to +/-10% tolerance
 Stall torque, rated torque and power relate to maximum continuous operation above 10 kHz drive switching frequency
 Maximum intermittent winding temperature is 284 °F (140 °C)

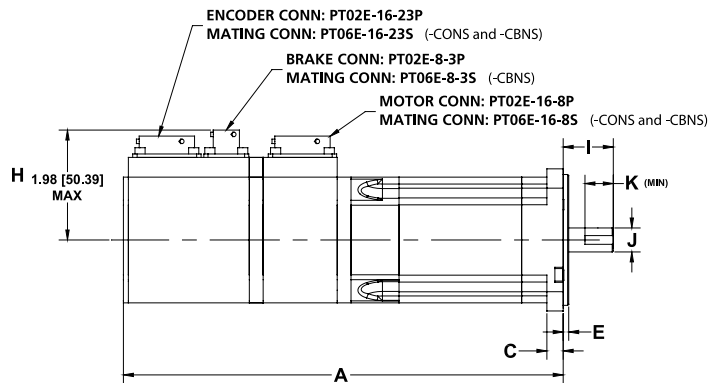
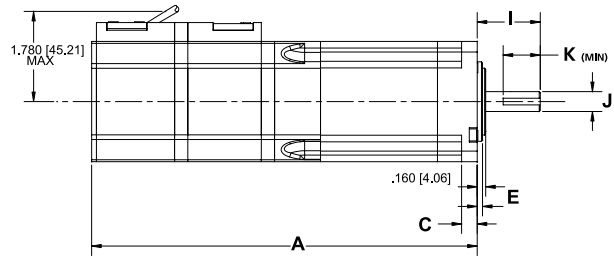
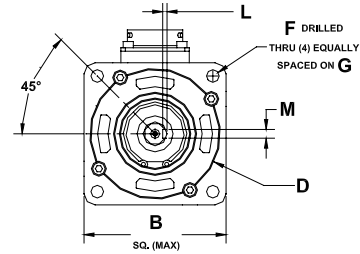

Motor Dimensions	English Flange				Metric Flange				
	NTE-207		NTE-212		NTM-207		NTM-212		
	(in)	(mm)	(in)	(mm)	(in)	(mm)	(in)	(mm)	
Unbraked Length — CONS/EONS*	A	5.55	141.0	6.55	166.4	5.55	141.0	6.55	166.4
Braked Length — TONS/LONS/FONS		4.39	111.5	5.39	136.9	4.39	111.5	5.39	136.9
Unbraked Length — CBNS/EBNS*		6.94	176.4	7.94	201.8	6.94	176.4	7.94	201.8
Braked Length — TBNS/LBNS/FBNS		6.28	159.4	7.94	201.8	6.28	159.4	7.28	184.8
Flange Square	B	2.27	57.7	2.27	57.7	2.57	65.2	2.57	65.2
Flange Thickness	C	0.29	7.5	0.29	7.5	0.29	7.5	0.29	7.5
Pilot Diameter	D	1.50	38.1	1.50	38.1	2.36	60.0	2.36	60.0
Pilot Thickness	E	0.10	2.5	0.10	2.5	0.10	2.5	0.10	2.5
Bolt Hole Diameter	F	0.21	5.2	0.21	5.2	0.23	5.8	0.23	5.8
Bolt Circle Diameter	G	2.63	66.7	2.63	66.7	2.95	75.0	2.95	75.0
Connector Height — CONS	H	1.92	48.9	1.92	48.9	1.92	48.9	1.92	48.9
Connector Height — TONS/LONS		1.78	45.2	1.78	45.2	1.78	45.2	1.78	45.2
Connector Height — CBNS		1.98	50.4	1.98	50.4	1.98	50.4	1.98	50.4
Connector Height — TBNS/LBNS		1.78	45.2	1.78	45.2	1.78	45.2	1.78	45.2
Shaft Length	I	1.21	30.7	1.21	30.7	0.93	23.5	0.93	23.5
Shaft Diameter	J	0.37	9.5	0.37	9.5	0.43	11.0	0.43	11.0
Shaft Key Dimensions					Shaft Key Dimensions				
Keyway Length (min)	K	0.70	17.8	0.70	17.8	0.51	13.0	0.51	13.0
Keyway Depth	L	0.08	2.0	0.08	2.0	0.08	2.1	0.08	2.1
Keyway Width	M	0.13	3.2	0.13	3.2	0.16	4.0	0.16	4.0

NOTE:
 *Not all variations are represented above; see our website for complete mechanical dimension drawings

NT Motor 3-inch Frame Ratings and Dimensions

Motor Frame Size (in)		3			
Voltage (Vrms)		230			
Model	NT-320	NT-330	NT-345	NT-355	
Continuous Stall Torque (lb-in)	19.7	31.5	47.5	55.5	
Continuous Stall Torque (Nm)	2.2	3.56	5.31	6.27	
Inertia (lb-in-sec ²)	0.000328	0.000438	0.000668	0.000888	
Inertia (kgm ²)	0.000037	0.000049	0.000075	0.000100	
Peak Torque (lb-in)	59.0	94.5	141.0	166.0	
Peak Torque (Nm)	6.67	10.68	15.93	18.75	
Cogging (lb-in) (typ.)	0.18	0.315	0.47	0.555	
Cogging (Nm) (typ.)	0.020	0.036	0.053	0.063	
Motor Weight (lbs)	6.0	7.3	10.0	12.3	
Motor Weight (kg)	2.72	3.31	4.54	5.58	
Number of Poles	8	8	8	8	
3000 rpm	Kt (lb-in/A) =		7.13	7.30	
	Kt (Nm/A) =		0.806	0.825	
	Ke (V/k rpm) =		50.0	50.0	
	Rated Torque (lb-in)		47.0	55.5	
	Rated Torque (Nm)		5.31	6.27	
	Stall Current (A)		6.59	7.6	
	Rated Power (kW)		1.668	1.97	
	R (ph-ph) (Ohms)		1.3	1.0	
	L (ph-ph) (mH)		17.0	13.0	
	4000 rpm	Kt (lb-in) =	3.50	5.04	
Kt (Nm/A) =		0.40	0.569		
Ke (V/k rpm) =		29.0	36.0		
Rated Torque (lb-in)		16.0	31.6		
Rated Torque (Nm)		1.8	3.56		
Stall Current (A)		5.4	6.25		
Rated Power (kW)		0.757	1.49		
R (ph-ph) (Ohms)		1.5	1.2		
L (ph-ph) (mH)		16.0	15.0		

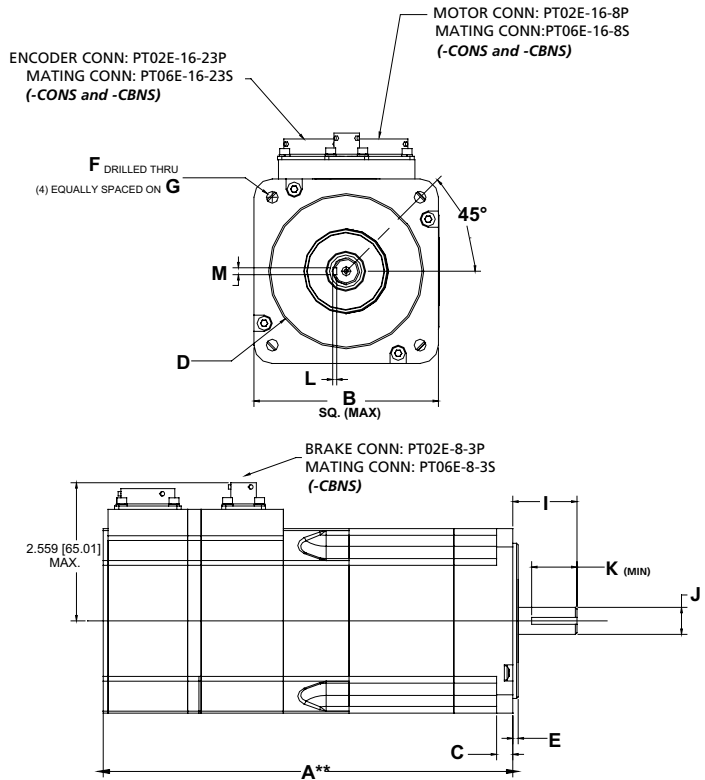

NOTES:
 Δt= 212 °F (100 °C) winding 104 °F (40 °C) maximum ambient; all data subject to +/-10% tolerance
 Stall torque, rated torque and power relate to maximum continuous operation above 10 kHz drive switching frequency
 Max. intermittent winding temperature is 284 °F (140 °C)

Motor Dimensions	English Flange								Metric Flange								
	NTE-320		NTE-330		NTE-345		NTE-355		NTM-320		NTM-330		NTM-345		NTM-355		
	(in)	(mm)	(in)	(mm)	(in)	(mm)	(in)	(mm)	(in)	(mm)	(in)	(mm)	(in)	(mm)	(in)	(mm)	
Unbraked Length — CONS/EONS*	5.22	132.5	5.82	147.8	7.02	178.3	9.42	239.2	5.22	132.5	5.82	147.8	7.02	178.3	9.42	239.2	
Braked Length — TONS/LONS/FONS	5.22	132.5	5.82	147.8	7.02	178.3	9.43	239.6	5.22	132.5	5.82	147.8	7.02	178.3	9.43	239.6	
Unbraked Length — CBNS/EBNS*	7.24	184.0	7.84	199.2	9.04	229.7	11.44	290.7	7.24	184.0	7.84	199.2	9.04	229.7	11.44	290.7	
Braked Length — TBNS/LBNS/FBNS	7.24	184.0	7.84	199.2	9.04	229.7	11.44	290.7	7.24	184.0	7.84	199.2	9.04	229.7	11.44	290.7	
Flange Square	B	3.42	86.9	3.42	86.9	3.42	86.9	3.42	86.9	3.42	86.9	3.42	86.9	3.42	86.9	3.42	86.9
Flange Thickness	C	0.30	7.6	0.30	7.6	0.30	7.6	0.30	7.6	0.30	7.6	0.30	7.6	0.30	7.6	0.30	7.6
Pilot Diameter	D	2.88	73.0	2.88	73.0	2.88	73.0	2.88	73.0	3.15	80.0	3.15	80.0	3.15	80.0	3.15	80.0
Pilot Thickness	E	0.10	2.5	0.10	2.5	0.10	2.5	0.10	2.5	0.12	3.0	0.12	3.0	0.12	3.0	0.12	3.0
Bolt Hole Diameter	F	0.22	5.6	0.22	5.6	0.22	5.6	0.22	5.6	0.28	7.0	0.28	7.0	0.28	7.0	0.28	7.0
Bolt Circle Diameter	G	3.88	98.4	3.88	98.4	3.88	98.4	3.88	98.4	3.94	100.0	3.94	100.0	3.94	100.0	3.94	100.0
Connector Height — CONS		2.45	62.2	2.45	62.2	2.45	62.2	2.45	62.2	2.45	62.2	2.45	62.2	2.45	62.2	2.45	62.2
Connector Height — TONS/LONS		2.35	59.7	2.35	59.7	2.35	59.7	2.35	59.7	2.35	59.7	2.35	59.7	2.35	59.7	2.35	59.7
Connector Height — CBNS		2.56	65.0	2.56	65.0	2.56	65.0	2.56	65.0	2.56	65.0	2.56	65.0	2.56	65.0	2.56	65.0
Connector Height — TBNS/LBNS		2.50	63.5	2.50	63.5	2.50	63.5	2.50	63.5	2.50	63.5	2.50	63.5	2.50	63.5	2.50	63.5
Shaft Length	I	1.21	30.7	1.21	30.7	1.21	30.7	1.21	30.7	1.21	30.7	1.21	30.7	1.21	30.7	1.21	30.7
Shaft Diameter	J	0.50	12.7	0.50	12.7	0.50	12.7	0.50	12.7	0.55	14.0	0.55	14.0	0.55	14.0	0.55	14.0
Shaft Key Dimensions								Shaft Key Dimensions									
Keyway Length (min)	K	0.84	21.3	0.84	21.3	0.84	21.3	0.84	21.3	0.79	20.0	0.79	20.0	0.79	20.0	0.79	20.0
Keyway Depth	L	0.08	2.0	0.08	2.0	0.08	2.0	0.08	2.0	0.10	2.6	0.10	2.6	0.10	2.6	0.10	2.6
Keyway Width	M	0.13	3.2	0.13	3.2	0.13	3.2	0.13	3.2	0.20	5.1	0.20	5.1	0.20	5.1	0.20	5.1

NOTE:
 *Not all variations are represented above; see our website for complete mechanical dimension drawings

NT Motor Flying Lead and Connector Details

LBNS, LONS

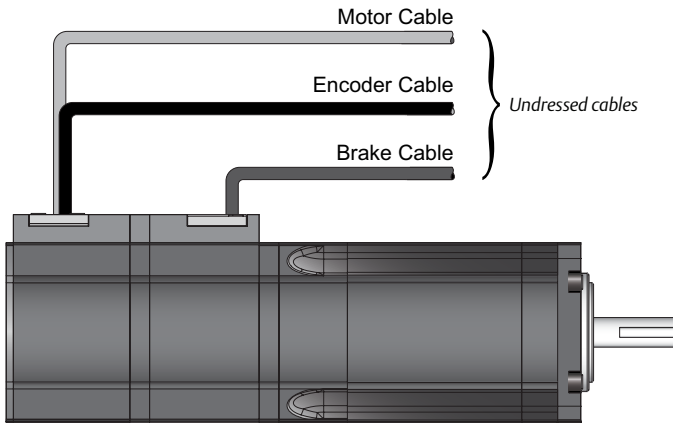

TBNS, TONS

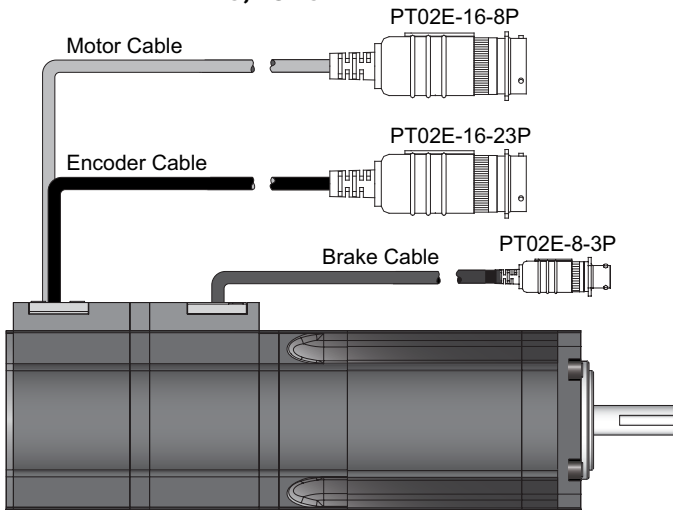

TBNS-DP, TONS-DP

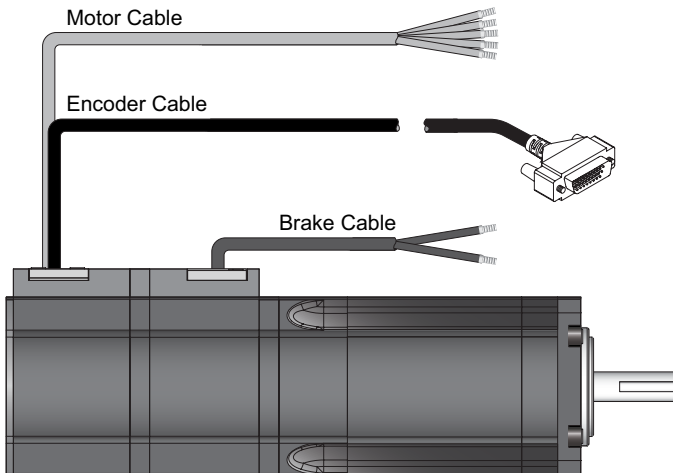

NOTE:
DP models include connector terminations specifically for Unidrive M, Unidrive SP, Epsilon EP and Digitax ST (DP-15)

NT Motor Flying Lead and Connector Details

FBNS, FONS

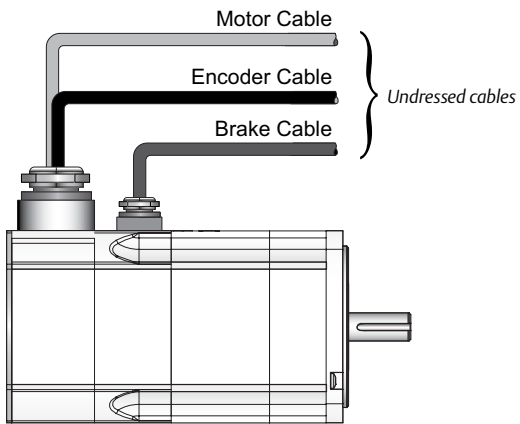

EBNS, EONS

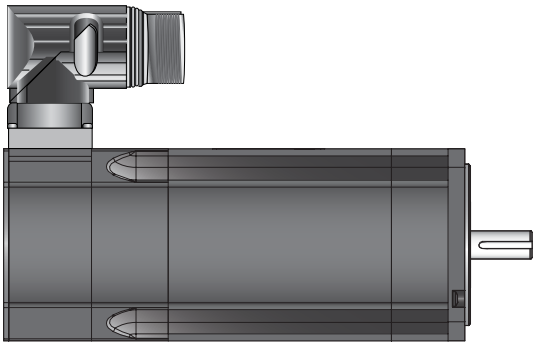

CBNS, CONS

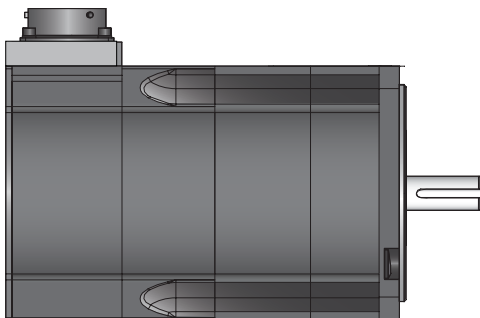

NT Motor Selection Considerations

Feedback Options

Feedback Device Order Code	Feedback Type	Encoder Supply Voltage	SinCos or Incremental Pulses per Revolution	Resolution Available to Position Loop	Feedback Accuracy
-T_NS, -C_NS, -L_NS, -E_NS, -F_NS	Incremental Encoder	5 Vdc	2048	16384 (14 bits)	±600 arc sec.

Motor Selection

Motor Derating

Any adverse operating conditions require that the motor performance be derated. These conditions include ambient temperature above 104 °F (40 °C), motor mounting position, drive switching frequency or a drive oversized for the motor.

Drive Switching Frequency

Most drive current ratings are reduced at higher switching frequencies. See individual drive manuals for details.

Mounting Arrangements

In general, motor torque should be derated if the motor mounting surface is heated from an external source such as a gearbox, the motor is connected to a poor thermal conductor, or the motor is mounted in a confined space with restricted air flow.

Thermal Test Conditions

The performance data shown was recorded with an ambient temperature of 68 °F (20 °C) and the motor mounted on a thermally-isolated aluminum plate.

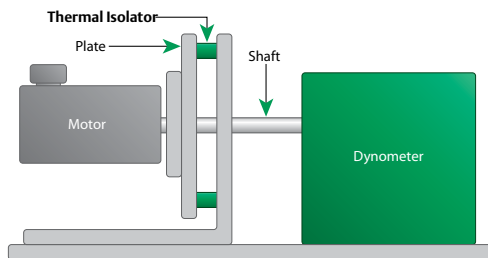

NT Motor Holding Brake Specifications

Motor Frame Size	Power Supply	Current	Static Torque		Mechanical Release Time	Mechanical Engagement Time	Added Inertia	
(in)	(Vdc)	(A)	(lb-in)	(Nm)	(ms)	(ms)	(lb-in-sec ²)	(kgm ²)
2	24	0.33	20.0	2.26	28.0	14.0	0.000106	0.000012
3	24	0.65	88.5	10.0	43.0	13.0	0.000968	0.000109

Motor Model	Frame Size	Mounting Plate Dimensions
NT	2"	6" x 6" x ¼"
	3"	10" x 10" x ⅜"

Brake Operation

Do not apply the brake while the motor shaft is rotating. The brake can only take a limited number of emergency braking operations and must not be used for repeated dynamic braking.

Thermal Protection

Thermistor protection to 284 °F (140 °C) is built into the motor windings and gives an indication of serious overheating problems. **The installer must connect the thermistor to the drive. Failure to do so will invalidate the motor warranty if winding burns out.**

Environmental Conditions

Any liquids or gases that may come into contact with the motor must be confirmed to ensure compliance with the correct international standards.

Ingress Protection

All NT Motors have shaft seals installed as standard. Standard models have an ingress rating (IP rating) of IP65. Lead configuration "E" models are rated IP67S. Configuration "F" models are rated IP68S.

NT Motor Selection Considerations

NT Series Servo Motor 230 V

The rugged NT motor is designed for the most stringent servo applications. Now available with multiple feedback options and white epoxy food-grade finish, the NT motor is an economical, high-performance motor made to maximize torque and minimize size. The NT motor uses powerful Neodymium magnets and is manufactured with a segmented core to maximize stator efficiency and further reduce size.

- Frame sizes in English (NEMA 23 or 34) or Metric (IEC-72-1)
- Flying lead cabling options
- IP65, IP67 & IP68 rating, UL, RoHS optional

- Continuous torque range up to 56 lb-in (6.3 Nm)
- Peak torque over 2.5 X continuous torque
- Low-inertia, high-performance motor
- Rated speeds: 3000, 4000 and 5000 rpm

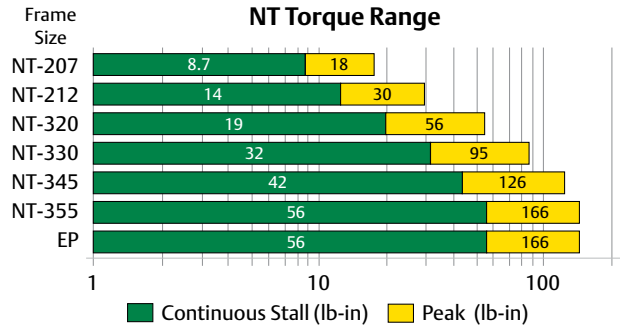

Sample Motor and Drive Combinations

Epsilon EP and NT Motor – 230 V, 1Ø														
Drive Model	Motor Model	Cont. Stall Torque		Peak Torque		Rated Torque		Rated Power		Rated Operating Speed rpm	Inertia		Kt	
		lb-in	Nm	lb-in	Nm	lb-in	Nm	HP	kW		lb-in sec ²	kgm ²	lb-in/Arms	Nm/Arms
EP202	NT207	7.5	0.80	22.50	2.54	7.30	0.82	0.58	0.43	5000	0.00009	0.000011	5.12	0.58
EP204	NT212	12.5	1.40	40.60	4.58	12.50	1.41	0.99	0.73	5000	0.00016	0.000019	5.08	0.57
EP 206	NT320	19.7	2.20	45.50	5.14	16.00	1.80	1.02	0.76	4000	0.00033	0.000037	3.50	0.40
EP206	NT330	31.5	3.50	65.52	7.40	31.50	3.55	2.00	1.49	4000	0.00044	0.000049	5.04	0.57
EP206	NT345	47.0	5.31	92.69	10.47	47.00	5.31	2.24	1.67	3000	0.00067	0.000075	7.13	0.81
EP209	NT355	55.5	6.27	131.40	14.84	55.50	6.27	2.64	1.96	3000	0.00089	0.000010	7.30	0.82

NOTES: Drive switching frequency 10 kHz unless noted



White epoxy food-grade option