

# H-Max™ HVAC Drives

## Application Manual

Effective January 2012  
New Information



# EATON

*Powering Business Worldwide*



## **Disclaimer of Warranties and Limitation of Liability**

The information, recommendations, descriptions and safety notations in this document are based on Eaton Corporation's ("Eaton") experience and judgment and may not cover all contingencies. If further information is required, an Eaton sales office should be consulted. Sale of the product shown in this literature is subject to the terms and conditions outlined in appropriate Eaton selling policies or other contractual agreement between Eaton and the purchaser.

THERE ARE NO UNDERSTANDINGS, AGREEMENTS, WARRANTIES, EXPRESSED OR IMPLIED, INCLUDING WARRANTIES OF FITNESS FOR A PARTICULAR PURPOSE OR MERCHANTABILITY, OTHER THAN THOSE SPECIFICALLY SET OUT IN ANY EXISTING CONTRACT BETWEEN THE PARTIES. ANY SUCH CONTRACT STATES THE ENTIRE OBLIGATION OF EATON. THE CONTENTS OF THIS DOCUMENT SHALL NOT BECOME PART OF OR MODIFY ANY CONTRACT BETWEEN THE PARTIES.

In no event will Eaton be responsible to the purchaser or user in contract, in tort (including negligence), strict liability or otherwise for any special, indirect, incidental or consequential damage or loss whatsoever, including but not limited to damage or loss of use of equipment, plant or power system, cost of capital, loss of power, additional expenses in the use of existing power facilities, or claims against the purchaser or user by its customers resulting from the use of the information, recommendations and descriptions contained herein. The information contained in this manual is subject to change without notice.

Cover Photo: Eaton H-Max HVAC Drives

## Support Services

The goal of Eaton is to ensure your greatest possible satisfaction with the operation of our products. We are dedicated to providing fast, friendly, and accurate assistance. That is why we offer you so many ways to get the support you need. Whether it's by phone, fax, or e-mail, you can access Eaton's support information 24 hours a day, seven days a week. Our wide range of services is listed below.

You should contact your local distributor for product pricing, availability, ordering, expediting, and repairs.

### Web Site

Use the Eaton Web site to find product information. You can also find information on local distributors or Eaton's sales offices.

### Web Site Address

[www.eaton.com/electrical](http://www.eaton.com/electrical)

### EatonCare Customer Support Center

Call the EatonCare Support Center if you need assistance with placing an order, stock availability or proof of shipment, expediting an existing order, emergency shipments, product price information, returns other than warranty returns, and information on local distributors or sales offices.

Voice: 877-ETN-CARE (386-2273) (8:00 a.m.–6:00 p.m. EST)

FAX: 800-752-8602

After-Hours Emergency: 800-543-7038  
(6:00 p.m.–8:00 a.m. EST)

If you are in the U.S. or Canada, and have OI or PLC questions, you can take advantage of our toll-free line for technical assistance with hardware and software product selection, system design and installation, and system debugging and diagnostics. Technical support engineers are available for calls during regular business hours.

### Technical Resource Center

Voice: 877-ETN-CARE (386-2273) (8:00 a.m.–5:00 p.m. EST)

FAX: 828-651-0549

e-mail: [TRC@Eaton.com](mailto:TRC@Eaton.com)

### European PanelMate Support Center

This engineering company, located in Zurich, Switzerland, provides high-level quality support and repair assistance for your PanelMate products. You will receive technical and application support.

#### For Customers in Europe, contact:

BFA Solutions, Ltd.

Voice: +41 1 806.64.44 (9:00 a.m.–5:00 p.m. CET)

e-mail: [gk@bfa.ch](mailto:gk@bfa.ch)

[www.bfa.ch](http://www.bfa.ch)

### Repair and Upgrade Service

Additional support is also available from our well-equipped Repair and Upgrade Service department. If you have questions regarding the repair or upgrade of an OI product, contact your local distributor.

### Repair and Upgrade Service (support for OI)

Voice:

877-ETN-CARE (877-386-2273) (8:00 a.m.–5:00 p.m. EST)

414-449-7100 (8:00 a.m.–5:00 p.m. EST)

FAX: 614-882-3414

e-mail: [TRC@eaton.com](mailto:TRC@eaton.com)

## Table of Contents

### SAFETY

Definitions and Symbols .....	<b>x</b>
Hazardous High Voltage .....	<b>x</b>
Warnings and Cautions .....	<b>x</b>
Important Safety Information .....	<b>x</b>

### H-MAX SERIES OVERVIEW

How to Use this Manual .....	<b>1</b>
Receiving and Inspection .....	<b>1</b>
Catalog Number Selection .....	<b>3</b>
Power Ratings and Product Selection .....	<b>4</b>

### HVAC APPLICATION

Specific Functions of Eaton HVAC Application .....	<b>6</b>
Example of Control Connections .....	<b>7</b>

### KEYPAD OF THE DRIVE

Keypad Display .....	<b>9</b>
Using the Graphical Keypad .....	<b>9</b>
Monitor .....	<b>14</b>

### EATON H-MAX—STARTUP

Startup Wizard .....	<b>15</b>
PID Mini-Wizard .....	<b>16</b>
Multi-Pump .....	<b>16</b>

### MENU STRUCTURE

Menu Structure .....	<b>17</b>
----------------------	-----------

### PARAMETER FUNCTIONS

Parameter Functions .....	<b>18</b>
---------------------------	-----------

### PARAMETERS

Basic Parameters .....	<b>21</b>
Analog Inputs .....	<b>22</b>
Digital Inputs .....	<b>24</b>
Analog Outputs .....	<b>32</b>
Digital Outputs .....	<b>33</b>
Drive Control .....	<b>37</b>
Protections .....	<b>39</b>
PID Controller .....	<b>41</b>

**Table of Contents, continued**

- I/O AND HARDWARE**
- Basic I/O ..... **56**
- Power Unit Settings ..... **57**
- Common Settings ..... **58**
- Monitoring ..... **58**
  
- USER SETTINGS**
- User Settings ..... **59**
  
- PARAMETER DESCRIPTIONS**
- Parameter Descriptions ..... **60**
  
- DIAGNOSTICS**
- Fault Codes ..... **72**
- Counters ..... **76**
- Software ..... **76**
  
- COMMUNICATIONS**
- BACnet Protocol ..... **77**
- Modbus Protocol ..... **93**
- N2 Open System Protocol ..... **115**

## List of Figures

Rating Plate . . . . .	2
Approval Sticker . . . . .	2
Carton Labels (U.S. and Europe) . . . . .	2
Control Connections . . . . .	7
US Keypad Buttons . . . . .	8
EMEA Keypad Buttons . . . . .	8
Main Menu . . . . .	9
Editing Values on Graphical Keypad . . . . .	10
Accessing Control Page . . . . .	11
Parameter Copy . . . . .	12
Help Text Example . . . . .	13
Adding Item To Favorites . . . . .	13
Multi-Monitoring Page . . . . .	14
Principal Example Diagram of BACnet . . . . .	77
AC Drive Components (BACnet) . . . . .	78
BACnet Ethernet Cable . . . . .	78
RS-485 Cable Strip . . . . .	78
RS-485 Cable Strip (Aluminum Shield) . . . . .	78
H-Max AC Drive Terminals (BACnet) . . . . .	79
RS-485 Ground . . . . .	79
RS-485 Bus Termination Setup . . . . .	80
BACnet MS/TP Bus Termination . . . . .	80
Fault Tracing Diagram for BACnet MS/TP . . . . .	91
Fault Tracing Diagram for BACnet IP . . . . .	92
Basic Structure of Modbus Frame . . . . .	93
Principal Example Diagram of Modbus . . . . .	93
AC Drive Components (Modbus) . . . . .	95
Modbus Ethernet Cable . . . . .	95
RS-485 Cable Strip . . . . .	95
RS-485 Cable Strip (Aluminum Shield) . . . . .	95
H-Max AC Drive Terminals (Modbus) . . . . .	96
RS-485 Ground . . . . .	96
RS-485 Bus Termination Setup . . . . .	97
Modbus RTU Bus Termination . . . . .	97
ID Map Initialization . . . . .	107
Fault Tracing Diagram for Modbus RTU . . . . .	112
Fault Tracing Diagram for Modbus TCP . . . . .	113
AC Drive Components (N2) . . . . .	115
N2 Cable Strip . . . . .	116
N2 Cable Strip (Aluminum Shield) . . . . .	116
H-Max AC Drive Terminals (N2 Protocol) . . . . .	116
N2 Ground . . . . .	117
N2 Bus Termination Setup . . . . .	117
N2 Bus Termination . . . . .	118
Principal Example Diagram of Metasys N2 . . . . .	120
Fault Tracing Diagram for N2 . . . . .	125

**List of Tables**

H-Max Series Open Drives	3
NEMA Type 1/IP21 or NEMA Type 12/IP44	4
NEMA Type 1/IP21 or NEMA Type 12/IP44	5
H-Max Series Adjustable Frequency Drive Option Boards	5
Keypad Menus	17
Basic Monitoring Functions	18
Timer Monitoring Functions	19
Multi-Monitor Functions	19
Basic Settings	21
Analog Input 1	22
Analog Input 2	22
Analog Input 3	22
Analog Input 4	23
Analog Input 5	23
Analog Input 6	23
Basic Settings	23
Digital Input 1	24
Digital Input 2	24
Digital Input 3	25
Digital Input 4	26
Digital Input 5	27
Digital Input 6	28
Digital Input Ext 1	29
Digital Input Ext 2	30
Basic Settings	31
Analog Output 1	32
Digital Output 1	33
Digital Output 2	34
Digital Output 3	35
Supervision	36
Basic Settings	37
Skip Frequencies	38
Motor Control	38
Faults	39
Automatic Reset	40
Basic Settings	41
Setpoints	42
Feedbacks	44
Feedforward	45
Process Supervision	46
Pressure Loss Compensation	46
Basic Settings	47
Setpoints	48
Feedbacks	49
Process Supervision	50
Fixed Frequencies	50



**List of Tables, continued**

Fire Mode .....	51
Multi-Pump .....	51
Braking .....	51
Fieldbus .....	52
Motor 2 .....	52
Drive Control 2 .....	52
Interval 1 .....	53
Interval 2 .....	53
Interval 3 .....	54
Interval 4 .....	54
Interval 5 .....	55
Timer 1 .....	55
Timer 2 .....	55
Timer 3 .....	55
Basic Parameters .....	56
Real-Time Clock .....	57
Fan Control .....	57
Sine Filter .....	57
Keypad .....	57
RS-485 .....	58
Ethernet .....	58
Modbus TCP .....	58
BACnet IP .....	58
Monitoring .....	58
User Settings .....	59
P2.1... .....	60
P2.2... .....	60
P2.3... .....	62
P2.4... .....	62
P2.5... .....	63
P2.6... .....	63
P2.7... .....	64
P2.8... .....	64
P2.9... .....	66
P2.10... .....	69
P2.11... .....	69
P2.12... .....	69
P2.13... .....	70
P2.14... .....	70
P2.15... .....	70
P2.16... .....	71
Active Faults .....	72
Reset Faults .....	72
Fault History .....	72
Fault Codes and Descriptions .....	72
Total Counters .....	76
Trip Counters .....	76
Software Information .....	76
BACnet MS/TP Protocol .....	77
BACnet IP Protocol .....	77

**List of Tables, continued**

Parameters .....	82
Monitoring Values .....	82
Ethernet Common Settings (M4.8.1) .....	83
BACnet IP Settings .....	83
Monitoring Values .....	83
BACnet MS/TP—Good Messages .....	84
BACnet MS/TP—Bad Frames .....	84
BACnet IP—Good Messages .....	85
BACnet IP—Bad Frames .....	85
Object Types and Properties Supported .....	86
Binary Value Object .....	87
Analog Value Object .....	88
Control Word Bits .....	89
Status Word Bits .....	89
Typical Fault Conditions .....	90
Modbus RTU Protocol .....	94
Modbus TCP Protocol .....	94
Parameters .....	99
Monitoring Values .....	99
Common Settings for Modbus TCP (Ethernet) .....	100
Modbus TCP Settings .....	100
Monitoring Values .....	100
Parity Type .....	101
FB Protocol Statuses .....	101
Modbus RTU—Good Messages .....	101
Modbus RTU—Bad Frames .....	101
FB Protocol Statuses .....	102
Modbus TCP—Good Messages .....	102
Modbus TCP—Bad Frames .....	102
Supported Functions .....	103
Defined Coil Registers .....	104
Defined Input Discrete .....	104
Defined Input Holding Registers .....	104
Parameter IDs .....	104
Fieldbus Process Data IN .....	105
Control Word Bits .....	105
Fieldbus Process Data OUT .....	106
Status Word Bits B1–B28 .....	106
Status Word Bits B29–B31 (Descriptions of Bit Connections) .....	106
Parameter Values in 16-bit IDMap Read/Write Registers .....	107
Parameter Values in 32-bit IDMap Read/Write Registers .....	107
Operation Day Counter .....	107
Resettable Operation Day Counter .....	107
Energy Counter .....	107
Resettable Energy Counter .....	107
Fault History .....	108
Typical Fault Conditions .....	111
Process Data OUT Variables .....	114

**List of Tables, continued**

N2 Protocol .....	115
Parameters .....	119
Monitoring Values .....	119
FB Protocol Statuses .....	120
N2—Good Messages .....	120
N2—Bad Frames .....	120
Analog Inputs (AI) .....	122
Binary Inputs (BI) .....	122
Analog Outputs (AO) .....	123
Binary Outputs (BO) .....	123
Integral Integers (ADI) .....	123
Typical Fault Conditions .....	124
Process Data OUT Variables .....	126

## Safety

### Definitions and Symbols

---

 **WARNING**

---

**This symbol indicates high voltage. It calls your attention to items or operations that could be dangerous to you and other persons operating this equipment. Read the message and follow the instructions carefully.**

---



This symbol is the "Safety Alert Symbol." It occurs with either of two signal words: CAUTION or WARNING, as described below.

---

---

 **WARNING**

---

**Indicates a potentially hazardous situation which, if not avoided, can result in serious injury or death.**

---

---

 **CAUTION**

---

Indicates a potentially hazardous situation which, if not avoided, can result in minor to moderate injury, or serious damage to the product. The situation described in the CAUTION may, if not avoided, lead to serious results. Important safety measures are described in CAUTION (as well as WARNING).

---

### Hazardous High Voltage

---

 **WARNING**

---

**Motor control equipment and electronic controllers are connected to hazardous line voltages. When servicing drives and electronic controllers, there may be exposed components with housings or protrusions at or above line potential. Extreme care should be taken to protect against shock.**

Stand on an insulating pad and make it a habit to use only one hand when checking components. Always work with another person in case an emergency occurs. Disconnect power before checking controllers or performing maintenance. Be sure equipment is properly grounded. Wear safety glasses whenever working on electronic controllers or rotating machinery.

### Warnings and Cautions

This manual contains clearly marked cautions and warnings which are intended for your personal safety and to avoid any unintentional damage to the product or connected appliances.

**Please read the information included in cautions and warnings carefully.**

---

---

 **WARNING**

---

**The relay outputs and other I/O-terminals may have a dangerous control voltage present even when H-Max is disconnected from mains.**

---

---

 **WARNING**

---

**Be sure not to plug the Ethernet/BACnet IP cable to the terminal under the keypad! This might harm your personal computer.**

---

---

 **WARNING**

---

**Be sure not to plug the Modbus TCP cable to the terminal under the keypad! This might harm your personal computer.**

---

---

 **CAUTION**

---

Remove external Control signal before resetting the fault to prevent unintentional restart of the drive.

---

### Important Safety Information

#### Hazardous High Voltage

---

 **WARNING**

---

**The components of the power unit of H-Max are live when the AC drive is connected to mains potential. Coming into contact with this voltage is extremely dangerous and may cause death or severe injury.**

---

---

 **WARNING**

---

**The motor terminals U, V, W and the brake resistor terminals are live when H-Max is connected to mains, even if the motor is not running.**

---

**⚠ WARNING**

---

After disconnecting the AC drive from the mains, wait until the indicators on the keypad go out (if no keypad is attached see the indicators on the cover). Wait 5 more minutes before doing any work on the connections of H-Max. Do not open the cover before this time has expired. After expiration of this time, use a measuring equipment to absolutely ensure that no voltage is present. Always ensure absence of voltage before starting any electrical work!

---

**⚠ WARNING**

---

The control I/O-terminals are isolated from the mains potential. However, the relay outputs and other I/O-terminals may have a dangerous control voltage present even when H-Max is disconnected from mains.

---

**⚠ WARNING**

---

Before connecting the AC drive to mains make sure that the front and cable covers of H-Max are closed.

---

**⚠ WARNING**

---

During a ramp stop (see the Application Manual), the motor is still generating voltage to the drive. Therefore, do not touch the components of the AC drive before the motor has completely stopped. Wait until the indicators on the keypad go out (if no keypad is attached see the indicators on the cover). Wait additional 5 minutes before starting any work on the drive.

**Important Warnings**

---

**⚠ WARNING**

---

H-Max AC drive is meant for fixed installations only.

---

**⚠ WARNING**

---

Do not perform any measurements when the AC drive is connected to the mains.

---

**⚠ WARNING**

---

The ground leakage current of H-Max AC drives exceeds 3.5mA AC. According to standard EN61800-5-1, a reinforced protective ground connection must be ensured. See chapter 1.3.

---

**⚠ WARNING**

---

If the AC drive is used as a part of a machine, the machine manufacturer is responsible for providing the machine with a supply disconnecting device (EN 60204-1).

---

**⚠ WARNING**

---

Only spare parts delivered by Eaton can be used.

---

**⚠ WARNING**

---

At power-up, power brake or fault reset the motor will start immediately if the start signal is active, unless the pulse control for Start/Stop logic has been selected. Furthermore, the I/O functionalistic (including start inputs) may change if parameters, applications or software are changed. Disconnect, therefore, the motor if an unexpected start can cause danger.

---

**⚠ WARNING**

---

The motor starts automatically after automatic fault reset if the auto restart function is activated. See the Application Manual for more detailed information.

---

**⚠ WARNING**

---

Prior to measurements on the motor or the motor cable, disconnect the motor cable from the AC drive.

---

**⚠ WARNING**

---

Do not touch the components on the circuit boards. Static voltage discharge may damage the components.

---

**⚠ WARNING**

---

Check that the EMC level of the AC drive corresponds to the requirements of your supply network.

## Additional Cautions



### CAUTION

The H-Max AC drive must always be grounded with an grounding conductor connected to the grounding terminal marked with .

The ground leakage current of H-Max exceeds 3.5 mA AC. According to EN61800-5-1, one or more of the following conditions for the associated protective circuit shall be satisfied:

- a) The protective conductor shall have a cross-sectional area of at least 10 mm<sup>2</sup> Cu or 16 mm<sup>2</sup> Al, through its total run.
- b) Where the protective conductor has a cross-sectional area of less than 10 mm<sup>2</sup> Cu or 16 mm<sup>2</sup> Al, a second protective conductor of at least the same cross-sectional area shall be provided up to a point where the protective conductor has a cross-sectional area not less than 10 mm<sup>2</sup> Cu or 16 mm<sup>2</sup> Al.
- c) Automatic disconnection of the supply in case of loss of continuity of the protective conductor.

The cross-sectional area of every protective grounding conductor which does not form part of the supply cable or cable enclosure shall, in any case, be not less than:

- 2.5 mm<sup>2</sup> if mechanical protection is provided or
- 4 mm<sup>2</sup> if mechanical protection is not provided. The ground fault protection inside the AC drive protects only the drive itself against ground faults in the motor or the motor cable. It is not intended for personal safety.

The ground fault protection inside the Ac drive protects only the drive itself against ground faults in the motor or the motor cable. It is not intended for personal safety.

Due to the high capacitive currents present in the AC drive, fault current protective switches may not function properly.

Do not perform any voltage withstand tests on any part of H-Max. There is a certain procedure according to which the tests shall be performed. Ignoring this procedure may result in damaged product.

## H-Max Series Overview

This chapter describes the purpose and contents of this manual, the receiving inspection recommendations and the H-Max Series Open Drive catalog numbering system.

### How to Use this Manual

The purpose of this manual is to provide you with information necessary to install, set and customize parameters, start up, troubleshoot and maintain the Eaton H-Max Series adjustable frequency drive (AFD). To provide for safe installation and operation of the equipment, read the safety guidelines at the beginning of this manual and follow the procedures outlined in the following chapters before connecting power to the H-Max Series AFD. Keep this operating manual handy and distribute to all users, technicians and maintenance personnel for reference.

### Receiving and Inspection

The H-Max Series AFD has met a stringent series of factory quality requirements before shipment. It is possible that packaging or equipment damage may have occurred during shipment. After receiving your H-Max Series AFD, please check for the following:

Check to make sure that the package includes the Installation Manual (MN04008005E), Quick Start Guide (MN04008004E) and accessory packet. The accessory packet includes:

- Rubber grommets
- EMC grounding clamps for power cables
- Control cable grounding clamps
- EMC jumper locking clips
- M4 screw for EMC level change (FS7 only)
- Additional grounding screw
- Real time clock battery
- UL conduit plate

Inspect the unit to ensure it was not damaged during shipment.

Make sure that the part number indicated on the nameplate corresponds with the catalog number on your order.

If shipping damage has occurred, please contact and file a claim with the carrier involved immediately.

If the delivery does not correspond to your order, please contact your Eaton Electrical representative.



**Note:** Do not destroy the packing. The template printed on the protective cardboard can be used for marking the mounting points of the H-Max AFD on the wall or in a cabinet.

# H-Max Series Overview

## Rating Plate

Type:	HMX34AG3D421-B	Made in Finland
Input:	Vin/Uin 3~AC, 380-480, 50/60 Hz, 3.4 A	
Output:	Vout/Uout 3~AC, 0- Vin/Uin, 0-320 Hz, 3.4 A @ 40°C, 2.7A @ 50°C	
Power (IL):	1.5HP: 480V / 1.1kW: 400V	
Chassis:	NEMA Type 1/IP21	
S/N:	123456789012	

## Approval Sticker

VAC LISTED  
9D42

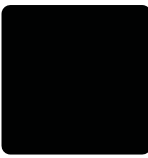

**S/N:123456789012**

**B.ID: 09391**  
**Code:123456789012345678901234567890123456789012345**

## Carton Labels (U.S. and Europe)



**AC DRIVE** 0020510471



Type: **HMX34AG01221-B**

S/N: V12345678901



Code:

Made in Finland

INPUT: Uin 3~ AC,380-480V, 50/60 Hz,12A  
 OUTPUT: 3~ AC, 0 -Uin, 0-320 Hz, 12A  
 Power (IL):5.5kW: 400V/7.5HP: 480V

Firmware:   
 Application:



POWER CONVERSION EQUIPMENT

Marks:

Style: **H34AG01221EB**

**EATON CORPORATION**

Frequency inverter  
Frequenzumrichter  
Convertisseur des fréquences

  
 1 234567 890128

07W09

U.S. Carton Label



**AC DRIVE** 0020510471

Type: **HMX34AG01221-B**

S/N: V12345678901



Code:

Made in Finland



INPUT: Uin 3~ AC,380-480V, 50/60 Hz,12A  
 OUTPUT: 3~ AC, 0 -Uin, 0-320 Hz, 12A  
 Power (IL):1.5HP: 480V/1.1kW: 400V

Firmware:   
 Application:



POWER CONVERSION EQUIPMENT

Marks:

Style: **H34AG01221MB**

Article: **126943**

**EATON GmbH**

Frequency inverter  
Frequenzumrichter  
Convertisseur des fréquences

  
 1 234567 890128

07W09

Europe Carton Label



## Catalog Number Selection

### H-Max Series Open Drives

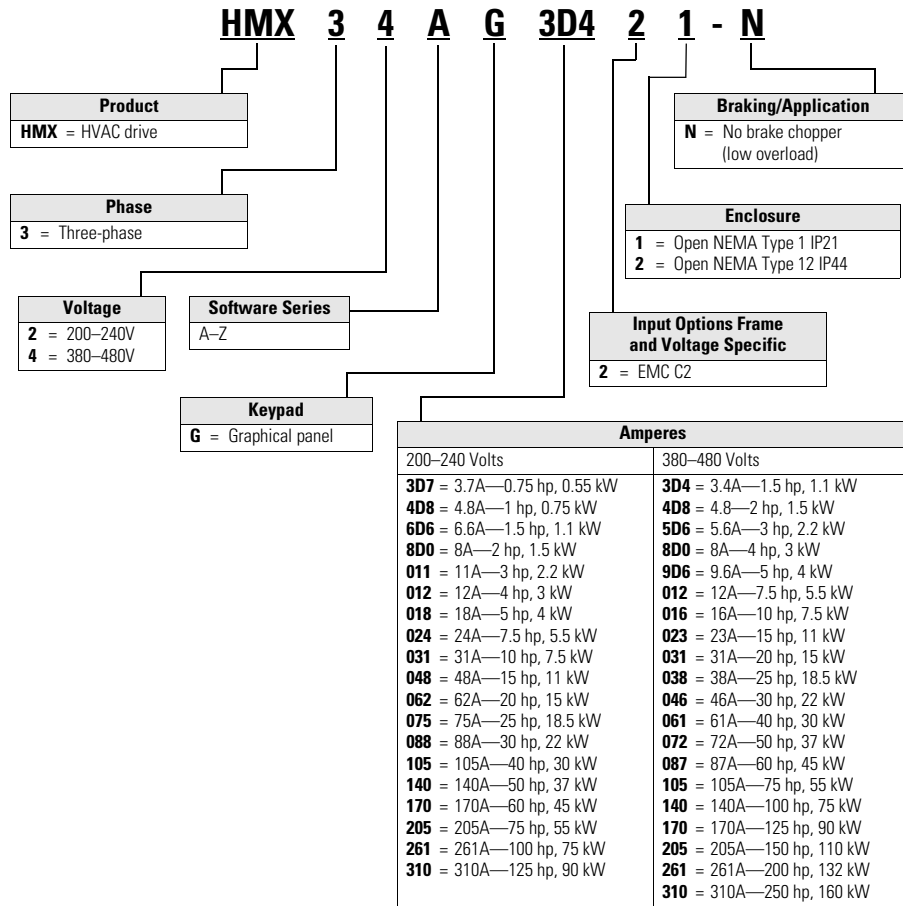

Standard Onboard Communications
<b>RS-485 Communications</b>
BACnet MS/TP = Master slave/token protocol (Universal BACnet) RS-485
Modbus RTU RS-485, ASCII or RTU, remote terminal unit 32 nodes
N2 = Johnson Controls® Metasys® N2 network
<b>Onboard Ethernet-Based Communications (port left side of keypad)</b>
BACnet/IP Ethernet industrial protocol
Modbus/TCP Transmission control protocol (Ethernet-based)

#### Notes

All boards are varnished (conformed coated). Corrosion resistant.  
 Battery included in all drives for real-time clock. Three year lifetime.  
 Keypad kit includes HOA bypass.  
 Keypad kit includes HOA, back reset for Europe application.  
 EMI/RFI filters included.  
 DC link choke included.

**Power Ratings and Product Selection**

**H-Max Series Drives—208–230 Volt**

**NEMA Type 1/IP21 or NEMA Type 12/IP44**

FS Frame Size	Drive Rated Current and hp				De-Rated Low Overload Full Load Amps at 50°C	Assigned Motor Ratings Open Drive kW 230V 50 Hz	_ Can Be: 1 = N1 = IP21 2 = N12 = IP44  Catalog Number
	Drive Rating Low Overload Full Load Amps at 40°C	230V 60 Hz Horsepower	Drive Input Amps	NEC Motor 60 Hz 230V Amps <sup>1</sup>			
FS4	3.7	0.75	3.2	3.2	2.6	0.55	HMX32AG3D72_-N
	4.8	1	4.3	4.2	3.7	0.75	HMX32AG4D82_-N
	6.6	1.5	6	6	4.6	1.1	HMX32AG6D62_-N
	8	2	7.2	6.8	6.6	1.5	HMX32AG8D02_-N
	11	3	9.7	9.6	8	2.2	HMX32AG0112_-N
	12.5	4	10.9	N/A	9	3	HMX32AG0122_-N
FS5	18	5	16.1	15.2	12.5	4	HMX32AG0182_-N
	24	7.5	21.7	22	18	5.5	HMX32AG0242_-N
	31	10	27.7	28	25	7.5	HMX32AG0312_-N
FS6	48	15	43.8	42	31	11	HMX32AG0482_-N
	62	20	57	54	48	15	HMX32AG0622_-N
FS7	75	25	69	68	62	18.5	HMX32AG0752_-N
	88	30	82.1	80	75	22	HMX32AG0882_-N
	105	40	99	104	88	30	HMX32AG1052_-N
FS8	140	50	133	130	114	37	HMX32AG1402_-N
	170	60	163	154	140	45	HMX32AG1702_-N
	205	75	198	192	170	55	HMX32AG2052_-N
FS9	261	100	256	248	211	75	HMX32AG2612_-N
	310	125	303	N/A	251	90	HMX32AG3102_-N

**Note**

<sup>1</sup> For sizing reference, full-load motor running currents—UL508C.

## H-Max Series Drives—380–480 Volt

## NEMA Type 1/IP21 or NEMA Type 12/IP44

FS Frame Size	Drive Input Rated Current and hp			NEC Motor 60 Hz 460V Amps <sup>1</sup>	De-Rated Low Overload Full Load Amps at 50°C	Assigned Motor Ratings Open Drive kW 400V 50 Hz	_ Can Be: 1 = N1 = IP21 2 = N12 = IP44  Catalog Number
	Low Overload Full Load Amps at 40°C	460V 60 Hz Horsepower	Drive Input Amps				
FS4	3.4	1.5	3.4	3	2.6	1.1	HMX34AG3D42_-N
	4.8	2	4.6	3.4	3.4	1.5	HMX34AG4D82_-N
	5.6	3	5.4	4.8	4.3	2.2	HMX34AG5D62_-N
	8.0	5	8.1	7.6	5.6	3.0	HMX34AG8D02_-N
	9.6	5	9.3	N/A	8	4	HMX34AG9D62_-N
	12	7.5	11.3	11	9.6	5.5	HMX34AG0122_-N
FS5	16	10	15.4	14	12	7.5	HMX34AG0162_-N
	23	15	21.3	21	16	11	HMX34AG0232_-N
	31	20	28.4	27	23	15	HMX34AG0312_-N
FS6	38	25	36.7	34	31	18.5	HMX34AG0382_-N
	46	30	43.6	40	38	22	HMX34AG0462_-N
	61	40	58.2	52	46	30	HMX34AG0612_-N
FS7	72	50	67.5	65	61	37	HMX34AG0722_-N
	87	60	85.3	77	72	45	HMX34AG0872_-N
	105	75	100.6	96	87	55	HMX34AG1052_-N
FS8	140	100	139.4	124	105	75	HMX34AG1402_-N
	170	125	166.5	156	140	90	HMX34AG1702_-N
	205	150	200	180	170	110	HMX34AG2052_-N
FS9	261	200	258	240	205	132	HMX34AG2612_-N
	310	250	303	302	251	160	HMX34AG3102_-N

## H-Max Series Adjustable Frequency Drive Option Boards

Option Board Part Number	Assigned to Control Module Slot:	Description
XXM-IO-B1-A	D or E	Expanded 6 digital output—two outputs are programmable as digital inputs or outputs
XXM-IO-B2-A	D or E	Expanded relay outputs—two programmable relays (each with a NO and NC contact) and thermistor input
XXM-IO-B4-A	D or E	Expanded analog inputs and outputs—one analog input and two analog outputs (isolated)
XXM-IO-B5-A	D or E	Expanded relay outputs—contains three programmable relays (one NO contact each)
XXM-IO-B9-A	D or E	Accepts up to five AC inputs (42–240 Vac) and one relay output (NO)
XXM-IO-BF-A	D or E	Expanded analog and digital output—one analog, one digital, and one relay output (NO)
XXM-COM-C4-A	D or E	LonWorks® communication

**Note**

<sup>1</sup> For sizing reference, full-load motor running currents—UL508C.

### HVAC Application

The Eaton HVAC drive contains a preloaded application for instant use and supports HVAC specific terminology and functionality. In addition, the H-Max drive uses a patented **Active Energy Control** algorithm. In addition to your drive efficiency, the controller works to minimize losses in your motor throughout the defined speed range delivering industry-leading energy efficiency.

### Specific Functions of Eaton HVAC Application

The Eaton HVAC application is an easy-to-use application for not only basic pump and fan applications where only one motor and one drive is needed, but also offers extensive possibilities for PID control.

#### Features

- Startup Wizard for extremely fast setup for basic pump or fan applications
- Mini-Wizards to ease the setup of applications
- Hand/Off/Auto button for easy change between Hand (keypad), OFF, and Auto (Remote control) place. The auto control place is selectable by parameter (I/O or Fieldbus)
- Control page for easy operation and monitoring of the most essential values
- Run interlock input (damper interlock). Drive will not start before this input is activated
- Different pre-heat modes used to avoid condensation problems
- Maximum output frequency 320 Hz
- Real-time clock and timer functions available (optional battery required). Possible to program three time channels to achieve different functions on the drive (for example, Start/Stop and Preset frequencies)
- External PID-controller available. Can be used to control a valve using the drive's I/O, for example
- Sleep mode function which automatically enables and disables drive running with user defined levels to save energy
- Two-zone PID-controller (two different feedback signals; minimum and maximum control)
- Two setpoint sources for the PID-control. Selectable with digital input
- PID setpoint boost function
- Feed forward function to improve the response to the process changes
- Process value supervision
- Multi-pump control
- Pressure loss compensation for compensating pressure losses in the pipework, for example, when sensor is incorrectly placed near the pump or fan

## Example of Control Connections

### Control Connections

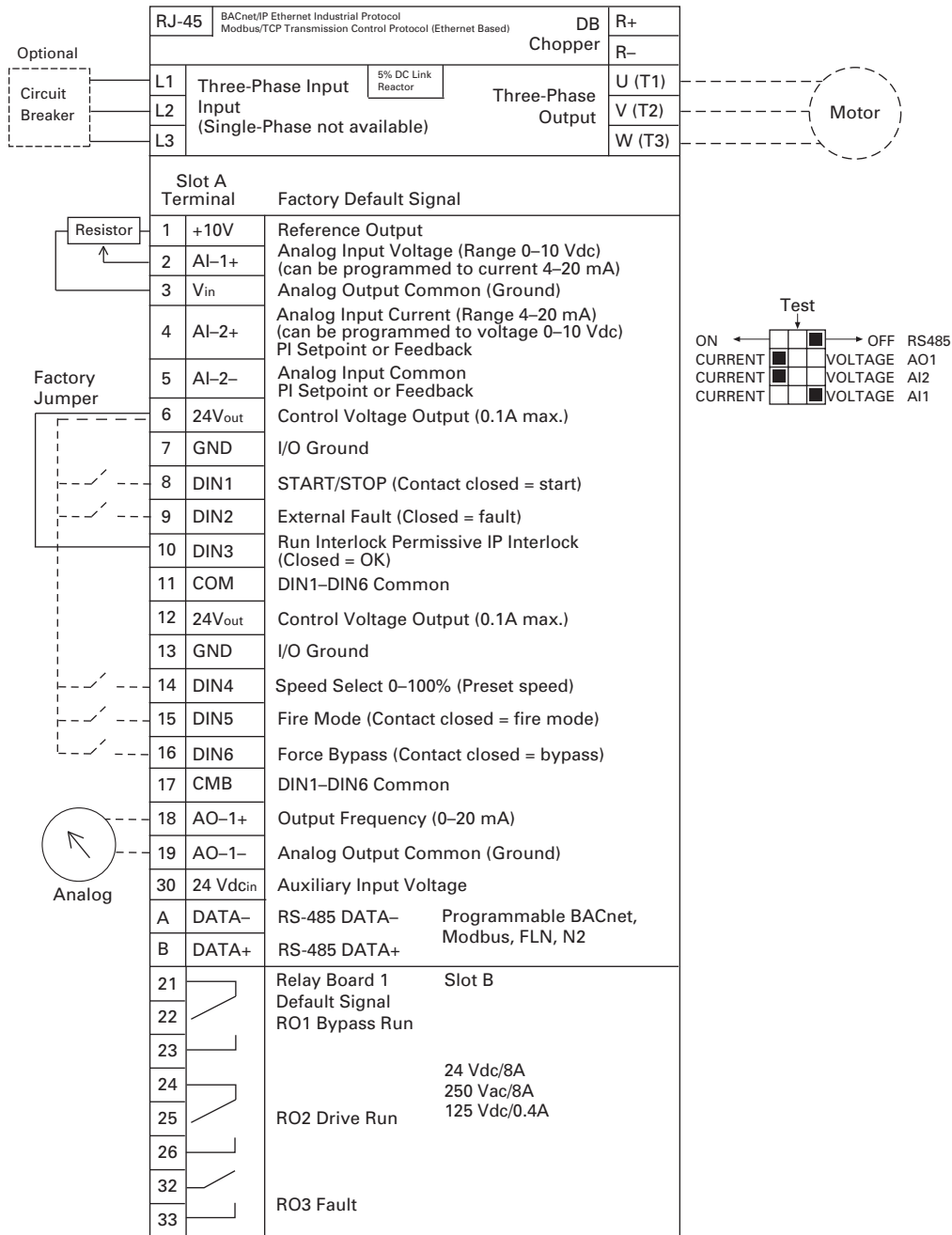

## Keypad of the Drive

The control keypad is the interface between the Eaton H-MAX frequency converter and the user. With the control keypad it is possible to control the speed of a motor, to supervise the state of the equipment and to set the frequency converter's parameters.

There are two different keypads used with the H-MAX drive. The North American Keypad is slightly different than the EMEA Keypad. Functionality is quite similar. The EMEA keypad does not support the bypass functionality commonly used in the United States.

### US Keypad Buttons

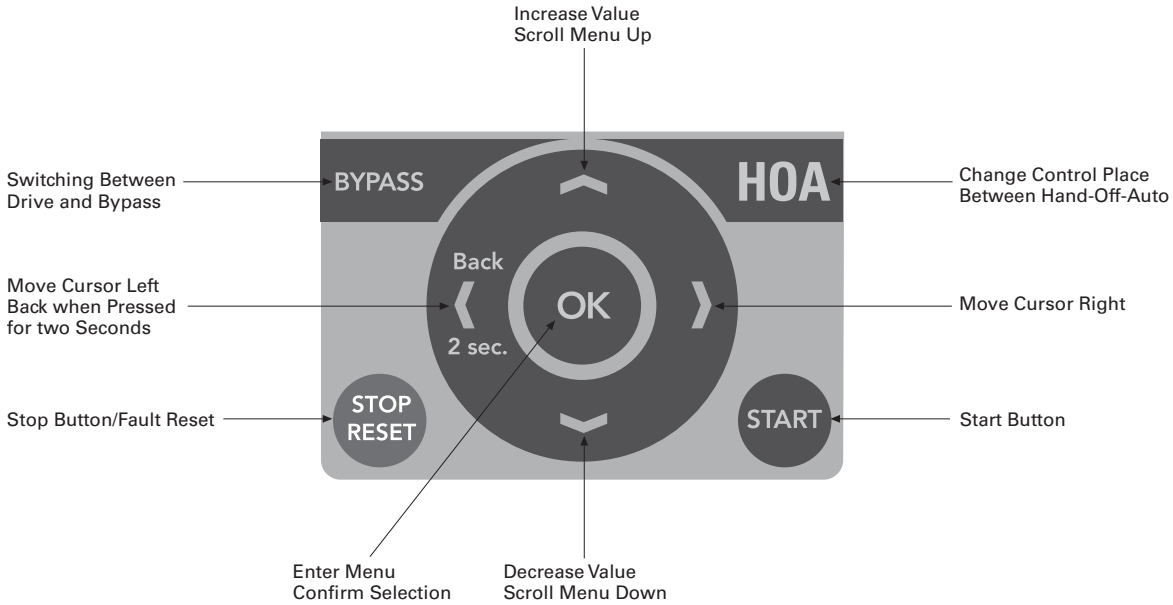

### EMEA Keypad Buttons

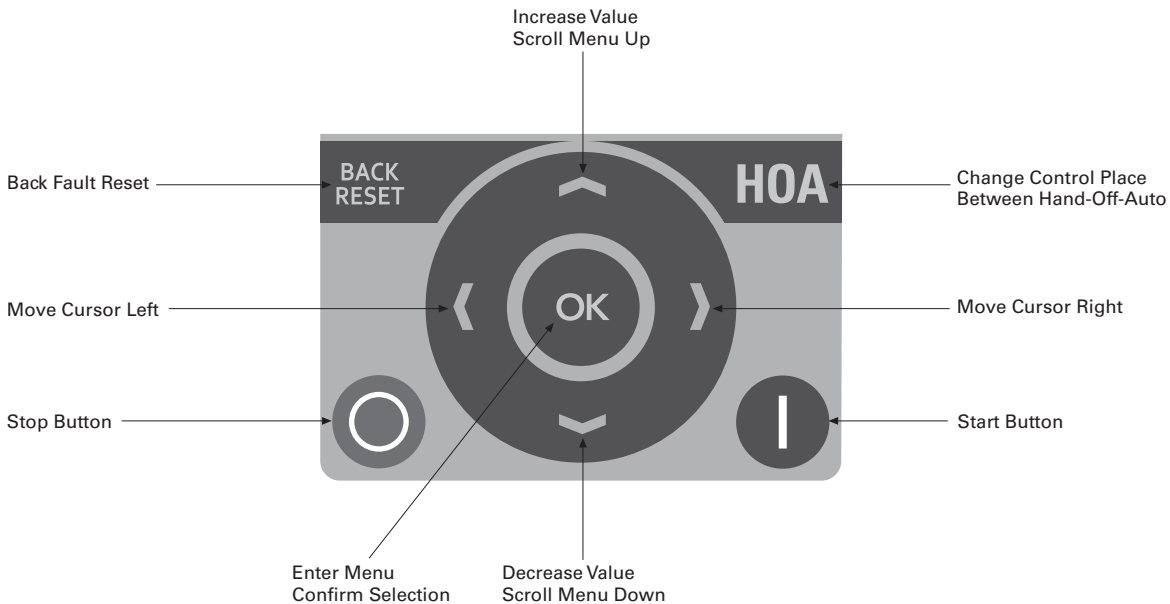

## Keypad Display

The keypad display indicates the status of the motor and the drive and any irregularities in motor or drive functions. On the display, the user sees information about his present location in the menu structure and the item displayed.

### Main Menu

The data on the control keypad are arranged in menus and submenus. Use the up and down arrows to move between the menus. Enter the group/item by pressing the OK button and return to the former level by pressing the Back/Reset button.

The *Location field* indicates your current location. The *Status field* gives information about the present status of the drive. See "Control Connections" on **Page 7**.

### Main Menu

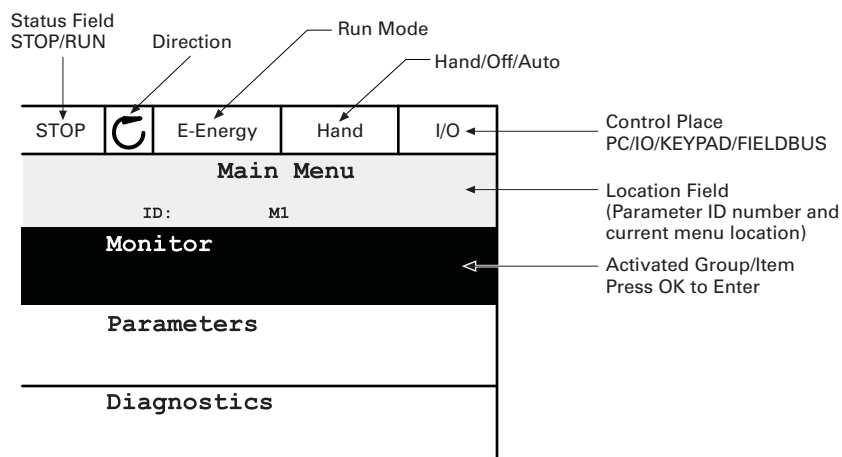

## Using the Graphical Keypad

### Editing Values

Change value of a parameter following the procedure below:

1. Locate the parameter.
2. Enter the *Edit* mode.
3. Set new value with the up/down arrow buttons. You can also move from digit to digit with the arrow buttons left/right if the value is numerical and then change the value with the up/down arrow buttons.
4. Confirm change with OK button or ignore change by returning to previous level with Back/Reset button.





### Accessing the Control Page

The *Control page* is meant for easy operation and monitoring of the most essential values.

1. Anywhere in the menu structure, push the *HOA* button.
2. Push the *arrow up* or the *arrow down* button to select *Control page* and confirm with the *OK* button.
3. The control page appears. If keypad control place and keypad reference are selected to be used, you can set the *Keypad reference* after having pressed the *OK* button. If other control places or reference values are used, the display will show Frequency reference which is not editable. The other values on the page are Multimonitoring values. You can choose which values appear here for monitoring (for this procedure, see Application Manual).

### Accessing Control Page

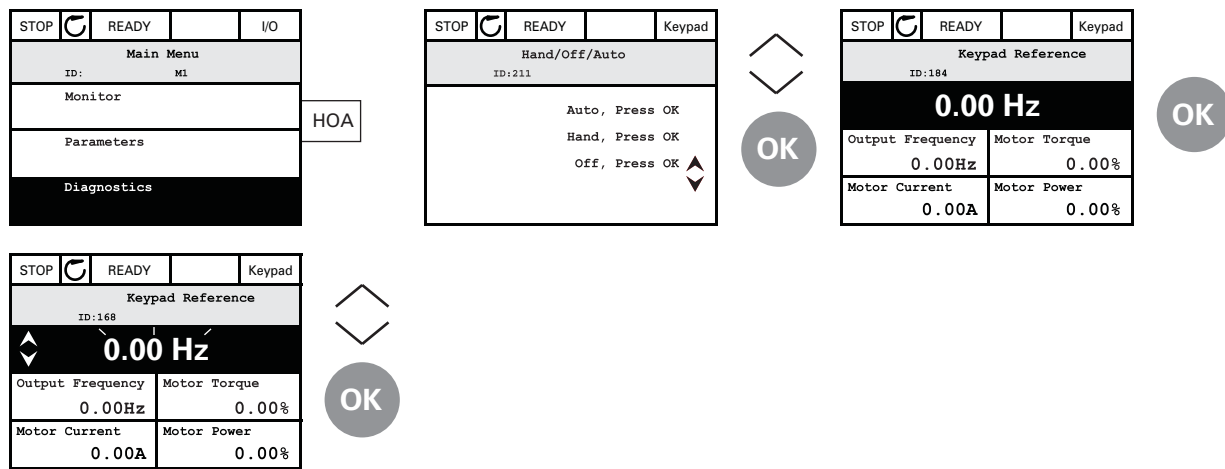

# Keypad of the Drive

## Copying Parameters

The parameter copy function can be used to copy parameters from one drive to another.

The parameters are first saved to the keypad, then the keypad is detached and connected to another drive. Finally, the parameters are downloaded to the new drive, restoring them from the keypad.

Before any parameters can successfully be copied from one drive to another, the drive has to be stopped when the parameters are downloaded.

- First, go into *User settings* menu and locate the *Parameter backup* submenu. In the *Parameter backup* submenu, there are three possible functions to be selected:
  1. *Restore factory defaults* will re-establish the parameter settings originally made at the factory.
  2. By selecting *Save to keypad* you can copy all parameters to the keypad.
  3. *Restore from keypad* will copy all parameters from keypad to a drive.

## Parameter Copy

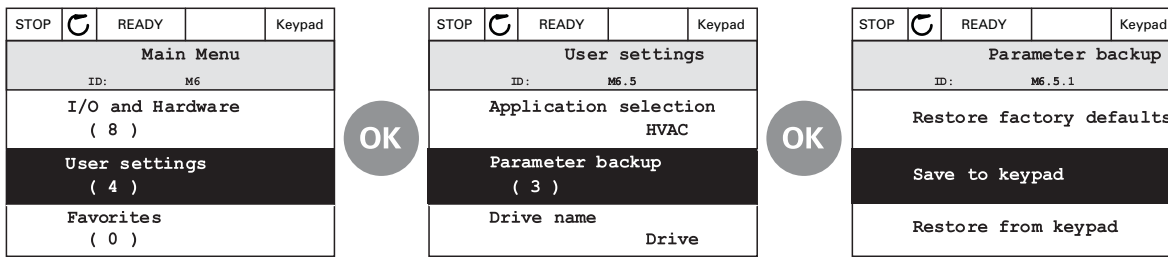

**Note:** If the keypad is changed between drives of different sizes, the copied values of these parameters will not be used:

- Motor nominal current (P2.1.12)
- Motor nominal voltage (P2.1.13)
- Motor nominal speed (P2.1.15)
- Motor power factor (P2.1.16)
- Motor nominal frequency (P2.1.14)
- Service factor (P2.1.18)
- Switching frequency (P2.7.7)
- Motor current limit (P2.1.17)
- Maximum frequency (P2.1.9)

### Help Texts

The graphical keypad features instant help and information displays for various items. All parameters offer an instant help display. Select Help and press the OK button. Text information is also available for faults, alarms, and the Startup Wizard.

### Help Text Example

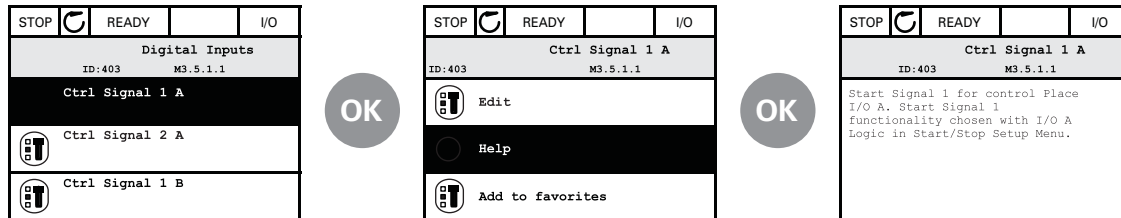

### Adding Item To Favorites

You might need to refer to certain parameter values or other items often. Instead of locating them one by one in the menu structure, you may want to add them to a folder called *Favorites* where they can easily be reached.

### Adding Item To Favorites

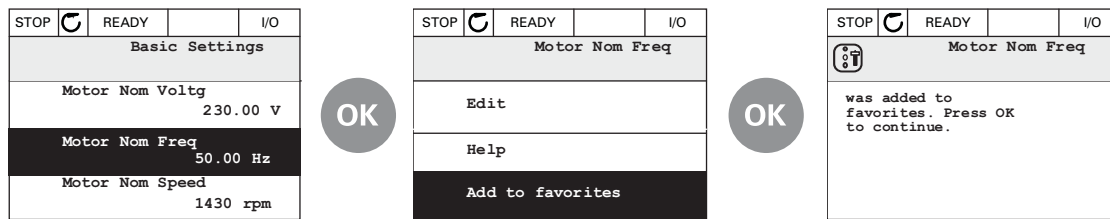

## Monitor

### Multi-Monitor

On the multi-monitor page, you can collect nine values that you wish to monitor.

#### Multi-Monitoring Page

STOP		READY		I/O
<b>Main Menu</b>				
ID: M1				
	Quick Setup ( 17 )			
	<b>Monitor</b> ( 5 )			
	Parameters ( 12 )			

OK

STOP		READY		I/O
<b>Monitor</b>				
ID: M2.1				
	<b>Multimonitor</b> (13)			
	Basic (13)			
	Timer functions (10)			

OK

STOP		READY		I/O
<b>Multimonitor</b>				
ID25 FreqReference				
FreqReference	Output Freq	Motor Speed		
20.0 Hz	0.00Hz	0.0rpm		
Motor Curre	Motor Torque	Motor Voltage		
0.00A	0.00%	0.0V		
DC-link volt	Unit Tempera	Motor Tempera		
0.0V	81.9°C	0.0%		

OK

STOP		READY		I/O
<b>FreqReference</b>				
ID:1 M2.1.1.1				
<input checked="" type="checkbox"/>	Output frequency	0.00 Hz		
<input checked="" type="checkbox"/>	FreqReference	10.00 Hz		
<input checked="" type="checkbox"/>	Motor Speed	0.00 rpm		
<input checked="" type="checkbox"/>	Motor Current	0.00 A		
<input checked="" type="checkbox"/>	Motor Torque	0.00 %		
<input type="checkbox"/>	Motor Power	0.00 %		

OK

Change the monitored value by activating the value cell (with arrow buttons left/right) and clicking OK. Then choose a new item on the Monitoring values list and click OK again.

## Eaton H-Max—Startup

### Startup Wizard

In the *Startup Wizard*, you will be prompted for essential information needed by the drive so that it can start controlling your process. In the Wizard, you will need the following keypad buttons:



Left/Right arrows. Use these to easily move between digits and decimals.



Up/Down arrows. Use these to move between options in menu and to change value.



OK button. Confirm selection with this button.



Back/Reset button. Pressing this button, you can return to the previous question in the Wizard. If pressed at the first question, the Startup Wizard will be cancelled.

Once you have connected power to your Eaton H-Max frequency converter, follow these instructions to easily set up your drive.

<b>1</b>	Run Startup Wizard	Yes No
<b>2</b>	Language Select	Depends on language package
<b>3</b>	Daylight Saving <sup>1</sup>	Russia US EU OFF
<b>4</b>	Time <sup>1</sup>	hh:mm:ss
<b>5</b>	Day <sup>1</sup>	dd.mm.
<b>6</b>	Year <sup>1</sup>	yyyy

**Note**

<sup>1</sup> These questions appear if battery is installed.

<b>7</b>	Application	H-Max Standard PID Multi-Pump
<b>8</b>	Bypass	Enabled Disabled
<b>9</b>	Motor Nominal Current	Min: 0.26A Max: Drive Dependent
<b>10</b>	Motor Nominal Voltage	Min: 180.0V Max: 690.0V
<b>11</b>	Motor Nominal Frequency	Min: 8 Hz Max: 320 Hz
<b>12</b>	Motor Nominal Speed	Min: 24 RPM Max: 19200 RPM
<b>13</b>	Min Frequency	Min: 0 Hz Max: 60 Hz
<b>14</b>	Max Frequency	Min: 12 Hz Max: 320 Hz
<b>15</b>	Accel Time 1	Min: 0.1s Max: 3000s
<b>16</b>	Decel Time 1	Min: 0.1s Max: 3000s
<b>17</b>	StartSourceHand	Keypad FieldbusCTRL I/O Three-Wire I/O Terminal
<b>18</b>	StartSourceAuto	I/O Terminal Keypad FieldbusCTRL I/O Three-Wire
<b>19</b>	SpeedSetptHand	Keypad Ref PID1 Activated AI1 + AI2 AI2 AI1 Fieldbus
<b>20</b>	SpeedSetptAuto	PID1 Activated AI1 + AI2 AI2 AI1 Fieldbus Keypad Ref

Now the Startup Wizard is done.

The Startup Wizard can be re-initiated by pressing and holding the back/reset button for two seconds. The Startup Wizard will appear upon next power up.

### PID Mini-Wizard

The PID Mini-Wizard is activated in the Quick Setup menu. This Wizard presupposes that you are going to use the PID controller in the “one feedback/one setpoint” mode. The control place will be I/O A and the default process unit “%”.

The PID Mini-Wizard asks for the following values to be set:

<b>1</b>	FeedBack1 Srce	AI2 AI1 Not Used ProceDataIn8 ProceDataIn7 ProceDataIn6 ProceDataIn5 ProceDataIn4 ProceDataIn3 ProceDataIn2 ProceDataIn1 AI6 AI5 AI4 AI3
<b>2</b>	Process Unit Selection	(Several Selections)
<b>3</b>	Process Unit Min	—
<b>4</b>	Process Unit Max	—
<b>5</b>	P-Gain	Min: 0% Max: 200%
<b>6</b>	Integration Time	Min: 0.00s Max: 600.00s
<b>7</b>	SetPT1 Source	Keypad SP1 Not Used ProceDataIn8 ProceDataIn7 ProceDataIn6 ProceDataIn5 ProceDataIn4 ProceDataIn3 ProceDataIn2 ProceDataIn1 AI6 AI5 AI4 AI3 AI2 AI1

### Multi-Pump

If Multi-Pump is the selected application, parameter group 2.12 will be visible in the menu structure. Default values may need to be adjusted to meet your application needs.

Parameter Group Name	Parameter Number	Parameter Name
Parameter Group 2.12: Multi-Pump	P2.12.1	Number of motors
	P2.12.2	Interlock function
	P2.12.3	Include FC
	P2.12.4	Autochange
	P2.12.5	Autochange interval
	P2.12.6	Autochange: frequency limit
	P2.12.7	Autochange: motor limit
	P2.12.8	Bandwidth
	P2.12.9	Bandwidth delay

## Menu Structure

### Keypad Menus

Monitor	Basic	Diagnostics	Active Faults
	Timer Functions		Reset Faults
	Multimonitor		Fault History
Parameters	Basic Parameters	I/O & Hardware	Total Counters
	Analog Inputs		Trip Counters
	Digital Inputs		Software Info
	Analog Outputs		Basic I/O
	Digital Outputs		Slot D
	Drive Control		Slot E
	Motor Control	Real Time Clock	
	Protections	Power Unit Settings	
	Fixed Frequencies	Keypad	
	Fire Mode	RS-485	
	Multi-Pump	Ethernet	
	Braking	User Settings	—
	Fieldbus	Favorites	—
	Second Parameter Set		
	Timer Functions		

## Parameter Functions

### Basic Monitoring Functions

Parameter Number	Parameter Name	Unit	ID	Description
V1.1.1	Output frequency	Hz	1	Output Frequency of the Drive
V1.1.2	Frequency Reference	Hz	25	Frequency Reference to Motor Control
V1.1.3	Motor Speed RPM	rpm	2	Motor speed in rpm
V1.1.4	Motor Current	A	3	Motor Current
V1.1.5	Motor Torque	%	4	Calculated Shaft Torque
V1.1.6	Motor Power %	%	5	Total Power Consumption of AC Drive
V1.1.7	Motor Voltage	V	6	Motor Voltage
V1.1.8	DC-Link Voltage	V	7	DC-Link Voltage
V1.1.9	Unit Temperature	°C	8	Heatsink temperature
V1.1.10	Motor Temperature	%	9	Calculated Motor Temperature
V1.1.11	Analog Input 1	%	13	Analog input signal scaled according to the range or custom min and max chosen in the I/O config menu
V1.1.12	Analog Input 2	%	14	Analog input signal scaled according to the range or custom min and max chosen in the I/O config menu
V1.1.13	Analog Output 1	%	26	Value of analog output in % of the signal range
V1.1.14	DI1, DI2, DI3	Binary	15	This monitor value shows the status of the I/Os
V1.1.15	DI4, DI5, DI6	Binary	16	This monitor value shows the status of the I/Os
V1.1.16	PID1 Setpoint	%	20	Setpoint value fed to the PID controller in process units
V1.1.17	PID1 Feedback	%	21	Feedback Value fed to the PID controller in process units
V1.1.18	PID1 Error	%	22	Error value of the PID controller. Deviation of the feedback from setpoint in process units.
V1.1.19	PID2 Setpoint	%	83	Setpoint value fed to the PID controller in process units
V1.1.20	PID2 Feedback	%	84	Feedback Value fed to the PID controller in process units
V1.1.21	PID2 Error	%	85	Error value of the PID controller. Deviation of the feedback from setpoint in process units.
V1.1.22	Drive Status Word	BitCoded	43	Bitcoded status of the drive. B1=Ready, B2=Run, B3=Fault, B6=RunEnable, B7=Alarm Active, B12=Run Request, B13=Motor Regulator Active
V1.1.23	Motor Speed %	%	1360	Percent of full motor speed
V1.1.24	Last Active Fault	Num	37	The fault code of the latest activated fault that has not been reset



**Timer Monitoring Functions**

Parameter Number	Parameter Name	Unit	ID	Description
V1.2.1	TC1, TC2, TC3	ON/OFF	1703	This monitor value shows the status of the time channels
V1.2.2	Interval 1	ON/OFF	1704	This monitor value shows the status of the timer interval
V1.2.3	Interval 2	ON/OFF	1705	This monitor value shows the status of the timer interval
V1.2.4	Interval 3	ON/OFF	1706	This monitor value shows the status of the timer interval
V1.2.5	Interval 4	ON/OFF	1707	This monitor value shows the status of the timer interval
V1.2.6	Interval 5	ON/OFF	1708	This monitor value shows the status of the timer interval
V1.2.7	Timer 1	sec	1709	If the timer has been activated, this monitor value shows the remaining time of the timer.
V1.2.8	Timer 2	sec	1710	If the timer has been activated, this monitor value shows the remaining time of the timer.
V1.2.9	Timer 3	sec	1711	If the timer has been activated, this monitor value shows the remaining time of the timer.
V1.2.10	Real Time Clock	h/m/s	1712	Time of Day (Military Time)

**Multi-Monitor Functions**

Parameter Number	Parameter Name	Unit	ID	Description
V1.3.x.1	Drive Status Word	Binary	43	Bitcoded status of the drive. B1=Ready, B2=Run, B3=Fault, B6=RunEnable, B7=Alarm Active, B12=Run Request, B13=Motor Regulator Active
V1.3.x.2	Analog Input 1	%	13	Analog input signal scaled according to the range or custom min and max chosen in the I/O config menu
V1.3.x.3	Analog Input 2	%	14	Analog input signal scaled according to the range or custom min and max chosen in the I/O config menu
V1.3.x.4	Analog Output 1	%	26	Value of analog output in % of the signal range
V1.3.x.5	AutoChange	N/A	1720	No Function
V1.3.x.6	DC-Link Voltage	V	7	DC-Link Voltage of the Drive
V1.3.x.7	DI1, DI2, DI3	Binary	15	This monitor value shows the status of the I/Os
V1.3.x.8	DI4, DI5, DI6	Binary	16	This monitor value shows the status of the I/Os
V1.3.x.9	RO1, RO2, RO3	Binary	17	This monitor value shows the status of the I/Os
V1.3.x.10	Frequency Reference	Hz	25	Frequency Reference to Motor Control
V1.3.x.11	Interval 1	ON/OFF	1704	This monitor value shows the status of the timer interval
V1.3.x.12	Interval 2	ON/OFF	1705	This monitor value shows the status of the timer interval
V1.3.x.13	Interval 3	ON/OFF	1706	This monitor value shows the status of the timer interval
V1.3.x.14	Interval 4	ON/OFF	1707	This monitor value shows the status of the timer interval
V1.3.x.15	Interval 5	ON/OFF	1708	This monitor value shows the status of the timer interval
V1.3.x.16	Motor Current	A	3	Motor Current
V1.3.x.17	Motor Power KW	KW	73	Calculated Power Consumption of the Motor
V1.3.x.18	Motor Power %	%	5	Total Power Consumption of AC Drive
V1.3.x.19	Motor Speed RPM	rpm	2	Motor speed in rpm
V1.3.x.20	Motor Torque	%	4	Calculated Shaft Torque
V1.3.x.21	Motor Voltage	V	6	Motor Voltage

**Note:** The “x” in the parameter number represents the assembled monitoring window. Values range from 1 to 9.

## Parameter Functions

### Multi-Monitor Functions, continued

Parameter Number	Parameter Name	Unit	ID	Description
V1.3.x.22	Motor Running	Binary	30	This monitor value shows if the motor is running
V1.3.x.23	Motor Temperature	%	9	Calculated Motor Temperature
V1.3.x.25	PID1 Status	Words	24	This monitor value shows if the PID is Active
V1.3.x.26	PID2 Status	Words	87	This monitor value shows if the PID is Active
V1.3.x.27	PID1 Error	%	22	Error value of the PID controller. Deviation of the feedback from setpoint in process units.
V1.3.x.28	PID1 Feedback	%	21	Feedback Value fed to the PID controller in process units
V1.3.x.29	PID1 Output	%	23	Output value delivered from the PID controller in process units
V1.3.x.30	PID1 Setpoint	%	20	Setpoint value fed to the PID controller in process units
V1.3.x.31	PID2 Error	%	85	Error value of the PID controller. Deviation of the feedback from setpoint in process units.
V1.3.x.32	PID2 Feedback	%	84	Feedback Value fed to the PID controller in process units
V1.3.x.33	PID2 Output	%	86	Output value delivered from the PID controller in process units
V1.3.x.34	PID2 Setpoint	%	83	Setpoint value fed to the PID controller in process units
V1.3.x.35	Real Time Clock	h/m/s	1712	Time of Day (Military Time)
V1.3.x.36	Run Request Chain	Words	1361	This monitor value shows the status of a run request
V1.3.x.37	TC1, TC2, TC3	ON/OFF	1703	This monitor value shows the status of the time channels
V1.3.x.38	Timer 1	sec	1709	If the timer has been activated, this monitor value shows the remaining time of the timer.
V1.3.x.39	Timer 2	sec	1710	If the timer has been activated, this monitor value shows the remaining time of the timer.
V1.3.x.40	Timer 3	sec	1711	If the timer has been activated, this monitor value shows the remaining time of the timer.
V1.3.x.41	Unit Temperature	°C	8	Heatsink temperature
V1.3.x.42	Motor Speed %	%	1360	Motor Speed in %
V1.3.x.43	Last Active Fault	Num	37	The fault code of the latest activated fault that has not been reset
V1.3.x.44	Run Time Hours	Hrs	1364	Drive Run Time in Hours
V1.3.x.45	Power On Hours	Hrs	1363	Power On Time in Hours
V1.3.x.46	Frequency Reference	Hz	1365	Frequency Reference to Motor Control
V1.3.x.53	Energy Counter	varies	2291	Amount of Energy taken from the Supply Network, No Reset
V1.3.x.55	Run Time	a d hh:min	N/A	Run Time of Drive
V1.3.x.56	Power On Time	a d hh:min	N/A	Power On Time of Drive
V1.3.x.57	Start Command Counter	Num	2295	The number of times the power unit has been started
V1.3.x.58	Energy Counter	varies	2296	Resettable Energy Counter
V1.3.x.60	Run Time	N/A	N/A	N/A
V1.3.x.61	Run Time	N/A	N/A	N/A
V1.3.x.62	Run Time	N/A	N/A	N/A
V1.3.x.63	Power On Time	N/A	N/A	N/A
V1.3.x.64	Power On Time	N/A	N/A	N/A
V1.3.x.65	Power On Time	N/A	N/A	N/A

**Note:** The “x” in the parameter number represents the assembled monitoring window. Values range from 1 to 9.

## Parameters

### Basic Parameters

#### Basic Settings

Parameter Number	Parameter Name	Change in Run	Min.	Max.	Default	ID	Values
P2.1.1	Application	N	0	2	0	213	0 = H-MAX Standard 1 = PID 2 = Multi-Pump
P2.1.2	ByPass	N	0	1	1	214	0 = Disabled 1 = Enabled
P2.1.3	HOA Control Stc	N	0	1	0	1359	0 = Keypad Ctrl 1 = I/O Terminal
P2.1.4	Start Srce Hand	N	0	3	0	1300	0 = Keypad 1 = I/O Terminal 2 = I/O 3-wire 3 = FieldbusCTRL
P2.1.5	Speed Setpt Hand	N	2	7	2	1301	2 = Keypad Ref 3 = Fieldbus 4 = AI1 5 = AI2 6 = AI1 + AI2 7 = PID1 Activated
P2.1.6	Start Srce Auto	N	0	3	1	1302	0 = Keypad 1 = I/O Terminal 2 = I/O 3-wire 3 = FieldbusCTRL
P2.1.7	Speed Setpt Auto (see P2.1.5)	N	2	7	4	1303	2 = Keypad Ref 3 = Fieldbus 4 = AI1 5 = AI2 6 = AI1 + AI2 7 = PID1 Activated
P2.1.8	Min Frequency	N	0,00 Hz	Max frequency	12,00 Hz	101	See Range
P2.1.9	Max Frequency	N	Min frequency	320,00 Hz	50,00/60,00	102	See Range
P2.1.10	Accel Time 1	Y	0.1 s	3000,0 s	60,0 s	103	See Range
P2.1.11	Decel Time 1	Y	0.1 s	3000,0 s	60,0 s	104	See Range
P2.1.12	Motor Nom Currnt	N	varies	varies	varies	113	See Range
P2.1.13	Motor Nom Voltg	N	180,0 V	690,0 V	varies	110	See Range
P2.1.14	Motor Nom Freq	N	12,00 Hz	320,00 Hz	50,00/60,00	111	See Range
P2.1.15	Motor Nom Speed	N	24 rpm	19200 rpm	1440/1750	112	See Range
P2.1.16	MotorPowerFactor	N	0,30	1,00	0,82	120	See Range
P2.1.17	Current Limit	N	varies	varies	varies	107	See Range
P2.1.18	Service Factor	N	0,10	2,00	1,00	1357	See Range

## Analog Inputs

### Analog Input 1

Parameter Number	Parameter Name	Change in Run	Min.	Max.	Default	ID	Values
P2.2.1.1	AI1 Signal selection (Input terminal, TTF)	N	—	—	AnINSlotA.1	377	AnIN Slot0.1 ... AnIN SlotE.n
P2.2.1.2	AI1 Signal Inv	Y	0	1	0	387	<b>0</b> = Normal <b>1</b> = Inverted
P2.2.1.3	AI1 Signal Range	Y	0	1	0	379	<b>0</b> = 0–10V / 0–20mA <b>1</b> = 2–10V / 4–20mA
P2.2.1.4	AI1 Custom Min	Y	–160,00 %	160,00 %	0,00 %	380	See Range
P2.2.1.5	AI1 Custom Max	Y	–160,00 %	160,00 %	100,00 %	381	See Range
P2.2.1.6	AI1 Filter Time	Y	0,00 s	300,00 s	1,00 s	378	See Range

### Analog Input 2

Parameter Number	Parameter Name	Change in Run	Min.	Max.	Default	ID	Values
P2.2.2.1	AI2 Signal selection (Input terminal, TTF)	N	—	—	AnINSlotA.2	388	AnIN Slot0.2 ... AnIN SlotE.n
P2.2.2.2	AI2 Signal Inv	Y	0	1	0	398	<b>0</b> = Normal <b>1</b> = Inverted
P2.2.2.3	AI2 Signal Range	Y	0	1	0	390	<b>0</b> = 0–10V / 0–20mA <b>1</b> = 2–10V / 4–20mA
P2.2.2.4	AI2 Custom Min	Y	–160,00 %	160,00 %	0,00 %	391	See Range
P2.2.2.5	AI2 Custom Max	Y	–160,00 %	160,00 %	100,00 %	392	See Range
P2.2.2.6	AI2 Filter Time	Y	0,00 s	300,00 s	1,00 s	389	See Range

### Analog Input 3

Parameter Number	Parameter Name	Change in Run	Min.	Max.	Default	ID	Values
P2.2.3.1	AI3 Signal selection (Input terminal, TTF)	N	—	—	AnIN Slot 0.1	141	AnIN Slot0.1 ... AnIN SlotE.n
P2.2.3.2	AI3 Signal Inv	Y	0	1	0	151	<b>0</b> = Normal <b>1</b> = Inverted
P2.2.3.3	AI3 Signal Range	Y	0	1	0	143	<b>0</b> = 0–10V / 0–20mA <b>1</b> = 2–10V / 4–20mA
P2.2.3.4	AI3 Custom Min	Y	–160,00 %	160,00 %	0,00 %	144	See Range
P2.2.3.5	AI3 Custom Max	Y	–160,00 %	160,00 %	100,00 %	145	See Range
P2.2.3.6	AI3 Filter Time	Y	0,00 s	300,00 s	1,00 s	142	See Range

## Analog Input 4

Parameter Number	Parameter Name	Change in Run	Min.	Max.	Default	ID	Values
P2.2.4.1	AI4 Signal selection (Input terminal, TTF)	N	—	—	AnIN Slot 0.1	152	AnIN Slot0.1 ... AnIN SlotE.n
P2.2.4.2	AI4 Signal Inv	Y	0	1	0	162	<b>0</b> = Normal <b>1</b> = Inverted
P2.2.4.3	AI4 Signal Range	Y	0	1	0	154	<b>0</b> = 0–10V / 0–20mA <b>1</b> = 2–10V / 4–20mA
P2.2.4.4	AI4 Custom Min	Y	–160,00 %	160,00 %	0,00 %	155	See Range
P2.2.4.5	AI4 Custom Max	Y	–160,00 %	160,00 %	100,00 %	156	See Range
P2.2.4.6	AI4 Filter Time	Y	0,00 s	300,00 s	1,00 s	153	See Range

## Analog Input 5

Parameter Number	Parameter Name	Change in Run	Min.	Max.	Default	ID	Values
P2.2.5.1	AI5 Signal selection (Input terminal, TTF)	N	—	—	AnIN Slot 0.1	188	AnIN Slot0.1 ... AnIN SlotE.n
P2.2.5.2	AI5 Signal Inv	Y	0	1	0	198	<b>0</b> = Normal <b>1</b> = Inverted
P2.2.5.3	AI5 Signal Range	Y	0	1	0	190	<b>0</b> = 0–10V / 0–20mA <b>1</b> = 2–10V / 4–20mA
P2.2.5.4	AI5 Custom Min	Y	–160,00 %	160,00 %	0,00 %	191	See Range
P2.2.5.5	AI5 Custom Max	Y	–160,00 %	160,00 %	100,00 %	192	See Range
P2.2.5.6	AI5 Filter Time	Y	0,00 s	300,00 s	1,00 s	189	See Range

## Analog Input 6

Parameter Number	Parameter Name	Change in Run	Min.	Max.	Default	ID	Values
P2.2.6.1	AI6 Signal selection (Input terminal, TTF)	N	—	—	AnIN Slot 0.1	199	AnIN Slot0.1 ... AnIN SlotE.n
P2.2.6.2	AI6 Signal Inv	Y	0	1	0	209	<b>0</b> = Normal <b>1</b> = Inverted
P2.2.6.3	AI6 Signal Range	Y	0	1	0	201	<b>0</b> = 0–10V / 0–20mA <b>1</b> = 2–10V / 4–20mA
P2.2.6.4	AI6 Custom Min	Y	–160,00 %	160,00 %	0,00 %	202	See Range
P2.2.6.5	AI6 Custom Max	Y	–160,00 %	160,00 %	100,00 %	203	See Range
P2.2.6.6	AI6 Filter Time	Y	0,00 s	300,00 s	1,00 s	200	See Range

## Basic Settings

Parameter Number	Parameter Name	Change in Run	Min.	Max.	Default	ID	Values
P2.2.7.1	Ref Scale Min.	Y	0,0 Hz	Max frequency	0,00 Hz	1307	See Range
P2.2.7.2	Ref Scale Max.	Y	0,0 Hz	Max frequency	0,00 Hz	1308	See Range

## Digital Inputs

### Digital Input 1

Parameter Number	Parameter Name	Change in Run	Min.	Max.	Default	ID	Values
P2.3.1.1	DI1 Open Invert	N	—	—	0	—	0 = Normally Open (Fixed)
P2.3.1.2	DI1 Function	N	—	—	0	—	0 = Start/Stop (Fixed)

### Digital Input 2

Parameter Number	Parameter Name	Change in Run	Min.	Max.	Default	ID	Values
P2.3.2.1	DIN 2 Invert	Y	0	1	0	1419	0 = Normally Open 1 = Normally Closed
P2.3.2.2	DIN2 Function	Y	1	33	2	1320	0 = Not used 1 = 3-wire Off 2 = External Fault 3 = Fault reset 4 = Run Enable (Drive & Bypass) 5 = Force Hand 6 = Force Auto 7 = Reverse 8 = Preset Freq Sel0 9 = Preset Freq Sel1 10 = Preset Freq Sel2 11 = Fire mode 12 = Interlock 1 13 = Interlock 2 14 = Interlock 3 15 = Reserved for future 16 = Reserved for future 17 = Preheat Function (DC-brake in stop state) 18 = Accel/Decel Sel 19 = Parameter Lock 20 = Unattended Start protection 21 = Second Param Set 22 = Timer 1 23 = Timer 2 24 = Timer 3 25 = Enable PID 26 = PID1 Select SetPt 27 = PID2 Select SetPt 28 = Motor 1 interlock 29 = Motor 2 interlock 30 = Motor 3 interlock 31 = Motor 4 interlock 32 = Motor 5 interlock (Future) 33 = Force Bypass

## Digital Input 3

Parameter Number	Parameter Name	Change in Run	Min.	Max.	Default	ID	Values
P2.3.3.1	DIN 3 Invert	Y	0	1	0	1420	<b>0</b> = Normally Open <b>1</b> = Normally Closed
P2.3.3.2	DIN3 Function	Y	1	33	12	1321	<b>0</b> = Not used <b>1</b> = 3-wire Off <b>2</b> = External Fault <b>3</b> = Fault reset <b>4</b> = Run Enable (Drive & Bypass) <b>5</b> = Force Hand <b>6</b> = Force Auto <b>7</b> = Reverse <b>8</b> = Preset Freq Sel0 <b>9</b> = Preset Freq Sel1 <b>10</b> = Preset Freq Sel2 <b>11</b> = Fire mode <b>12</b> = Interlock 1 <b>13</b> = Interlock 2 <b>14</b> = Interlock 3 <b>15</b> = Reserved for future <b>16</b> = Reserved for future <b>17</b> = Preheat Function (DC-brake in stop state) <b>18</b> = Accel/Decel Sel <b>19</b> = Parameter Lock <b>20</b> = Unattended Start protection <b>21</b> = Second Param Set <b>22</b> = Timer 1 <b>23</b> = Timer 2 <b>24</b> = Timer 3 <b>25</b> = Enable PID <b>26</b> = PID1 Select SetPt <b>27</b> = PID2 Select SetPt <b>28</b> = Motor 1 interlock <b>29</b> = Motor 2 interlock <b>30</b> = Motor 3 interlock <b>31</b> = Motor 4 interlock <b>32</b> = Motor 5 interlock (Future) <b>33</b> = Force Bypass

## Parameters

### Digital Input 4

Parameter Number	Parameter Name	Change in Run	Min.	Max.	Default	ID	Values
P2.3.4.1	DIN 4 Invert	Y	0	1	0	1421	<b>0</b> = Normally Open <b>1</b> = Normally Closed
P2.3.4.2	DIN4 Function	Y	1	33	8	1322	<b>0</b> = Not used <b>1</b> = 3-wire Off <b>2</b> = External Fault <b>3</b> = Fault reset <b>4</b> = Run Enable (Drive & Bypass) <b>5</b> = Force Hand <b>6</b> = Force Auto <b>7</b> = Reverse <b>8</b> = Preset Freq Sel0 <b>9</b> = Preset Freq Sel1 <b>10</b> = Preset Freq Sel2 <b>11</b> = Fire mode <b>12</b> = Interlock 1 <b>13</b> = Interlock 2 <b>14</b> = Interlock 3 <b>15</b> = Reserved for future <b>16</b> = Reserved for future <b>17</b> = Preheat Function (DC-brake in stop state) <b>18</b> = Accel/Decel Sel <b>19</b> = Parameter Lock <b>20</b> = Unattended Start protection <b>21</b> = Second Param Set <b>22</b> = Timer 1 <b>23</b> = Timer 2 <b>24</b> = Timer 3 <b>25</b> = Enable PID <b>26</b> = PID1 Select SetPt <b>27</b> = PID2 Select SetPt <b>28</b> = Motor 1 interlock <b>29</b> = Motor 2 interlock <b>30</b> = Motor 3 interlock <b>31</b> = Motor 4 interlock <b>32</b> = Motor 5 interlock (Future) <b>33</b> = Force Bypass



**Digital Input 5**

Parameter Number	Parameter Name	Change in Run	Min.	Max.	Default	ID	Values
P2.3.5.1	DIN 5 Invert	Y	0	1	0	1422	<b>0</b> = Normally Open <b>1</b> = Normally Closed
P2.3.5.2	DIN5 Function	Y	1	33	11	1323	<b>0</b> = Not used <b>1</b> = 3-wire Off <b>2</b> = External Fault <b>3</b> = Fault reset <b>4</b> = Run Enable (Drive & Bypass) <b>5</b> = Force Hand <b>6</b> = Force Auto <b>7</b> = Reverse <b>8</b> = Preset Freq Sel0 <b>9</b> = Preset Freq Sel1 <b>10</b> = Preset Freq Sel2 <b>11</b> = Fire mode <b>12</b> = Interlock 1 <b>13</b> = Interlock 2 <b>14</b> = Interlock 3 <b>15</b> = Reserved for future <b>16</b> = Reserved for future <b>17</b> = Preheat Function (DC-brake in stop state) <b>18</b> = Accel/Decel Sel <b>19</b> = Parameter Lock <b>20</b> = Unattended Start protection <b>21</b> = Second Param Set <b>22</b> = Timer 1 <b>23</b> = Timer 2 <b>24</b> = Timer 3 <b>25</b> = Enable PID <b>26</b> = PID1 Select SetPt <b>27</b> = PID2 Select SetPt <b>28</b> = Motor 1 interlock <b>29</b> = Motor 2 interlock <b>30</b> = Motor 3 interlock <b>31</b> = Motor 4 interlock <b>32</b> = Motor 5 interlock (Future) <b>33</b> = Force Bypass

## Parameters

### Digital Input 6

Parameter Number	Parameter Name	Change in Run	Min.	Max.	Default	ID	Values
P2.3.6.1	DIN 6 Invert	Y	0	1	0	1423	<b>0</b> = Normally Open <b>1</b> = Normally Closed
P2.3.6.2	DIN6 Function	Y	1	33	0	1324	<b>0</b> = Not used <b>1</b> = 3-wire Off <b>2</b> = External Fault <b>3</b> = Fault reset <b>4</b> = Run Enable (Drive & Bypass) <b>5</b> = Force Hand <b>6</b> = Force Auto <b>7</b> = Reverse <b>8</b> = Preset Freq Sel0 <b>9</b> = Preset Freq Sel1 <b>10</b> = Preset Freq Sel2 <b>11</b> = Fire mode <b>12</b> = Interlock 1 <b>13</b> = Interlock 2 <b>14</b> = Interlock 3 <b>15</b> = Reserved for future <b>16</b> = Reserved for future <b>17</b> = Preheat Function (DC-brake in stop state) <b>18</b> = Accel/Decel Sel <b>19</b> = Parameter Lock <b>20</b> = Unattended Start protection <b>21</b> = Second Param Set <b>22</b> = Timer 1 <b>23</b> = Timer 2 <b>24</b> = Timer 3 <b>25</b> = Enable PID <b>26</b> = PID1 Select SetPt <b>27</b> = PID2 Select SetPt <b>28</b> = Motor 1 interlock <b>29</b> = Motor 2 interlock <b>30</b> = Motor 3 interlock <b>31</b> = Motor 4 interlock <b>32</b> = Motor 5 interlock (Future) <b>33</b> = Force Bypass

**Digital Input Ext 1**

Parameter Number	Parameter Name	Change in Run	Min.	Max.	Default	ID	Values
P2.3.7.1	Ext-D1 Terminal (TTF method)	Y	—	—	DigiN Slot0.1	1325	DigiN Slot0.1 ... DigiN SlotE.n TimeChannel.1 ... TimeChannel.n
P2.3.7.2	Ext-D1 Function (options same as above)	Y	1	33	0	1326	<b>0</b> = Not used <b>1</b> = 3-wire Off <b>2</b> = External Fault <b>3</b> = Fault reset <b>4</b> = Run Enable (Drive & Bypass) <b>5</b> = Force Hand <b>6</b> = Force Auto <b>7</b> = Reverse <b>8</b> = Preset Freq Sel0 <b>9</b> = Preset Freq Sel1 <b>10</b> = Preset Freq Sel2 <b>11</b> = Fire mode <b>12</b> = Interlock 1 <b>13</b> = Interlock 2 <b>14</b> = Interlock 3 <b>15</b> = Reserved for future <b>16</b> = Reserved for future <b>17</b> = Preheat Function (DC-brake in stop state) <b>18</b> = Accel/Decel Sel <b>19</b> = Parameter Lock <b>20</b> = Unattended Start protection <b>21</b> = Second Param Set <b>22</b> = Timer 1 <b>23</b> = Timer 2 <b>24</b> = Timer 3 <b>25</b> = Enable PID <b>26</b> = PID1 Select SetPt <b>27</b> = PID2 Select SetPt <b>28</b> = Motor 1 interlock <b>29</b> = Motor 2 interlock <b>30</b> = Motor 3 interlock <b>31</b> = Motor 4 interlock <b>32</b> = Motor 5 interlock (Future) <b>33</b> = Force Bypass

## Parameters

### Digital Input Ext 2

Parameter Number	Parameter Name	Change in Run	Min.	Max.	Default	ID	Values
P2.3.8.1	Ext-D2 Terminal (TTF method)	Y	—	—	DigiN Slot0.1	1327	DigiN Slot0.1 ... DigiN SlotE.n TimeChannel.1 ... TimeChannel.n
P2.3.8.2	Ext-D2 Function (options same as above)	Y	1	33	0	1328	<b>0</b> = Not used <b>1</b> = 3-wire Off <b>2</b> = External Fault <b>3</b> = Fault reset <b>4</b> = Run Enable (Drive & Bypass) <b>5</b> = Force Hand <b>6</b> = Force Auto <b>7</b> = Reverse <b>8</b> = Preset Freq Sel0 <b>9</b> = Preset Freq Sel1 <b>10</b> = Preset Freq Sel2 <b>11</b> = Fire mode <b>12</b> = Interlock 1 <b>13</b> = Interlock 2 <b>14</b> = Interlock 3 <b>15</b> = Reserved for future <b>16</b> = Reserved for future <b>17</b> = Preheat Function (DC-brake in stop state) <b>18</b> = Accel/Decel Sel <b>19</b> = Parameter Lock <b>20</b> = Unattended Start protection <b>21</b> = Second Param Set <b>22</b> = Timer 1 <b>23</b> = Timer 2 <b>24</b> = Timer 3 <b>25</b> = Enable PID <b>26</b> = PID1 Select SetPt <b>27</b> = PID2 Select SetPt <b>28</b> = Motor 1 interlock <b>29</b> = Motor 2 interlock <b>30</b> = Motor 3 interlock <b>31</b> = Motor 4 interlock <b>32</b> = Motor 5 interlock (Future) <b>33</b> = Force Bypass

## Basic Settings

Parameter Number	Parameter Name	Change in Run	Min.	Max.	Default	ID	Values
P2.3.9.1	Start logic	Y	0	3	1	1304	0 = Normal 1 = Intlk start 2 = Intlk Time Start 3 = Delay start
P2.3.9.2	INTLK Timeout	N	0,00 s	320,00 s	5,00 s	1305	See Range
P2.3.9.3	Delay Time	N	0,00 s	320,00 s	5,00 s	1306	See Range
P2.3.9.4	Intrlk Stop Mode	N	0	1	0	1356	0 = Coasting 1 = Ramping
P2.3.9.5	Interlock 1 Text	Y	1	16	1	1315	1 = Ext Interlock Missing! 2 = Run enable Missing! 3 = Vibration Cutout 4 = High motor temperature 5 = Freeze Stat Trip 6 = Low Pressure detect 7 = High Pressure detect 8 = Low water detect 9 = Smoke detect 10 = 3-wire Off 11 = Damper Interlock 12 = Open Safety 13 = Seal Leakage 14 = Valve sequence 15 = Megger Shutdown 16 = High Pump Temp
P2.3.9.6	Interlock 2 Text	Y	1	16	1	1316	1 = Ext Interlock Missing! 2 = Run enable Missing! 3 = Vibration Cutout 4 = High motor temperature 5 = Freeze Stat Trip 6 = Low Pressure detect 7 = High Pressure detect 8 = Low water detect 9 = Smoke detect 10 = 3-wire Off 11 = Damper Interlock 12 = Open Safety 13 = Seal Leakage 14 = Valve sequence 15 = Megger Shutdown 16 = High Pump Temp

## Parameters

### Basic Settings, continued

Parameter Number	Parameter Name	Change in Run	Min.	Max.	Default	ID	Values
P2.3.9.7	Interlock 3 Text	Y	1	16	1	1317	<b>1</b> = Ext Interlock Missing! <b>2</b> = Run enable Missing! <b>3</b> = Vibration Cutout <b>4</b> = High motor temperature <b>5</b> = Freeze Stat Trip <b>6</b> = Low Pressure detect <b>7</b> = High Pressure detect <b>8</b> = Low water detect <b>9</b> = Smoke detect <b>10</b> = 3-wire Off <b>11</b> = Damper Interlock <b>12</b> = Open Safety <b>13</b> = Seal Leakage <b>14</b> = Valve sequence <b>15</b> = Megger Shutdown <b>16</b> = High Pump Temp

## Analog Outputs

### Analog Output 1

Parameter Number	Parameter Name	Change in Run	Min.	Max.	Default	ID	Values
P2.4.1.1	A01 Function	Y	0	15	2	10050	<b>0</b> = Forced 0% <b>1</b> = Forced 100% <b>2</b> = O/P Freq <b>3</b> = Freq Ref <b>4</b> = Motor speed <b>5</b> = O/P Current <b>6</b> = Motor torque <b>7</b> = Motor power <b>8</b> = Mot voltage <b>9</b> = DC-link volt <b>10</b> = PID1 Output <b>11</b> = PID2 Output <b>12</b> = PID1 Setpoint <b>13</b> = PID1 Feedback1 <b>14</b> = PID1 Feedback2 <b>15</b> = PID1 Error
P2.4.1.2	A01 Filter Time	Y	0,00 s	300,00 s	1,00 s	10051	See Range
P2.4.1.3	A01 Min Signal	Y	0	1	0	10052	<b>0</b> = 0mA / 0V <b>1</b> = 4mA / 2V
P2.4.1.4	A01 MinScale	Y	varies	varies	0,0	10053	See Range
P2.4.1.5	A01 MaxScale	Y	varies	varies	0,0	10054	See Range
P2.4.1.6	A01 Invert	Y	0	1	0	10060	<b>0</b> = No inversion <b>1</b> = Inverted

## Digital Outputs

### Digital Output 1

Parameter Number	Parameter Name	Change in Run	Min.	Max.	Default	ID	Values
P2.5.1.1	R01 function	N	0	37	2	11001	<b>0</b> = None <b>1</b> = Ready <b>2</b> = Run <b>3</b> = Fault <b>4</b> = Alarm <b>5</b> = Reverse <b>6</b> = At speed <b>7</b> = MotorRegAct <b>8</b> = Preset speed <b>9</b> = KeypadCTRL <b>10</b> = LimSuperv1 <b>11</b> = LimSuperv2 <b>12</b> = StartSignal <b>13</b> = Reserved (Future) <b>14</b> = Fire Mode On <b>15</b> = RTC T1 CTRL <b>16</b> = RTC T2 CTRL <b>17</b> = RTC T3 CTRL <b>18</b> = Wrong Direction <b>19</b> = Thermistor Fault <b>20</b> = PassThruComm <b>21</b> = Damper Control Relay <b>22</b> = Overheat Alarm <b>23</b> = External Fault <b>24</b> = 4mA / 2V Warning <b>25</b> = In Auto mode <b>26</b> = In Hand mode <b>27</b> = PID1 Sleep <b>28</b> = PID1 Superv. <b>29</b> = PID2 Superv. <b>30</b> = Motor 1 control <b>31</b> = Motor 2 control <b>32</b> = Motor 3 control <b>33</b> = Motor 4 control <b>34</b> = Motor 5 control <b>35</b> = Run Byp or Drive <b>36</b> = Bypass run <b>37</b> = Fault Reset
P2.5.1.2	R01 Invert	N	0	1	0	11020	<b>0</b> = No <b>1</b> = Yes
P2.5.1.3	R01 ON delay	Y	0,00 s	320,00 s	0,00 s	11002	See Range
P2.5.1.4	R01 OFF delay	Y	0,00 s	320,00 s	0,00 s	11003	See Range

## Parameters

### Digital Output 2

Parameter Number	Parameter Name	Change in Run	Min.	Max.	Default	ID	Values
<b>P2.5.2.1</b>	<b>R02 function</b>	N	0	37	2	11004	<b>0</b> = None <b>1</b> = Ready <b>2</b> = Run <b>3</b> = Fault <b>4</b> = Alarm <b>5</b> = Reverse <b>6</b> = At speed <b>7</b> = MotorRegAct <b>8</b> = Preset speed <b>9</b> = KeypadCTRL <b>10</b> = LimSuperv1 <b>11</b> = LimSuperv2 <b>12</b> = StartSignal <b>13</b> = Reserved (Future) <b>14</b> = Fire Mode On <b>15</b> = RTC T1 CTRL <b>16</b> = RTC T2 CTRL <b>17</b> = RTC T3 CTRL <b>18</b> = Wrong Direction <b>19</b> = Thermistor Fault <b>20</b> = PassThruComm <b>21</b> = Damper Control Relay <b>22</b> = Overheat Alarm <b>23</b> = External Fault <b>24</b> = 4mA / 2V Warning <b>25</b> = In Auto mode <b>26</b> = In Hand mode <b>27</b> = PID1 Sleep <b>28</b> = PID1 Superv. <b>29</b> = PID2 Superv. <b>30</b> = Motor 1 control <b>31</b> = Motor 2 control <b>32</b> = Motor 3 control <b>33</b> = Motor 4 control <b>34</b> = Motor 5 control <b>35</b> = Run Byp or Drive <b>36</b> = Bypass run <b>37</b> = Fault Reset
<b>P2.5.2.2</b>	<b>R02 Invert</b>	N	0	1	0	11021	<b>0</b> = No <b>1</b> = Yes
<b>P2.5.2.3</b>	<b>R02 ON delay</b>	Y	0,00 s	320,00 s	0,00 s	11005	See Range
<b>P2.5.2.4</b>	<b>R02 OFF delay</b>	Y	0,00 s	320,00 s	0,00 s	11006	See Range



**Digital Output 3**

Parameter Number	Parameter Name	Change in Run	Min.	Max.	Default	ID	Values
P2.5.3.1	R03 function	N	0	37	3	11007	<b>0</b> = None <b>1</b> = Ready <b>2</b> = Run <b>3</b> = Fault <b>4</b> = Alarm <b>5</b> = Reverse <b>6</b> = At speed <b>7</b> = MotorRegAct <b>8</b> = Preset speed <b>9</b> = KeypadCTRL <b>10</b> = LimSuperv1 <b>11</b> = LimSuperv2 <b>12</b> = StartSignal <b>13</b> = Reserved (Future) <b>14</b> = Fire Mode On <b>15</b> = RTC T1 CTRL <b>16</b> = RTC T2 CTRL <b>17</b> = RTC T3 CTRL <b>18</b> = Wrong Direction <b>19</b> = Thermistor Fault <b>20</b> = PassThruComm <b>21</b> = Damper Control Relay <b>22</b> = Overheat Alarm <b>23</b> = External Fault <b>24</b> = 4mA / 2V Warning <b>25</b> = In Auto mode <b>26</b> = In Hand mode <b>27</b> = PID1 Sleep <b>28</b> = PID1 Superv. <b>29</b> = PID2 Superv. <b>30</b> = Motor 1 control <b>31</b> = Motor 2 control <b>32</b> = Motor 3 control <b>33</b> = Motor 4 control <b>34</b> = Motor 5 control <b>35</b> = Run Byp or Drive <b>36</b> = Bypass run <b>37</b> = Fault Reset

## Parameters

### Supervision

Parameter Number	Parameter Name	Change in Run	Min.	Max.	Default	ID	Values
P2.5.9.1	Superv1 Item	Y	0	8	0	1622	<b>0</b> = Output frequency <b>1</b> = FreqReference <b>2</b> = Motor current <b>3</b> = Motor torque <b>4</b> = Motor power <b>5</b> = DC voltage <b>6</b> = AI1 <b>7</b> = AI2 <b>8</b> = Unit temperature
P2.5.9.2	Supervision #1 mode	Y	0	2	0	1623	<b>0</b> = Not used <b>1</b> = Low limit <b>2</b> = High limit
P2.5.9.3	Supervision #1 limit	Y	-214748,36	214748,36	25,00 Hz	1624	See Range
P2.5.9.4	Supervision #1 limit hysteresis	Y	0,00 Hz	100,00 Hz	5,00 Hz	1625	See Range
P2.5.9.5	Superv2 Item	Y	0	8	1	1626	<b>0</b> = Output frequency <b>1</b> = FreqReference <b>2</b> = Motor current <b>3</b> = Motor torque <b>4</b> = Motor power <b>5</b> = DC voltage <b>6</b> = AI1 <b>7</b> = AI2 <b>8</b> = Unit temperature
P2.5.9.6	Supervision #2 mode	Y	0	2	0	1627	<b>0</b> = Not used <b>1</b> = Low limit <b>2</b> = High limit
P2.5.9.7	Supervision #2 limit	Y	-214748,36	214748,36	40,00 Hz	1628	See Range
P2.5.9.8	Supervision #2 limit hysteresis	Y	0,00 Hz	100,00 Hz	5,00 Hz	1629	See Range

## Drive Control

### Basic Settings

Parameter Number	Parameter Name	Change in Run	Min.	Max.	Default	ID	Values
P2.6.1.1	Start Function	N	0	1	0	505	0 = Ramping 1 = Flying Start
P2.6.1.2	Stop Function	N	0	1	0	506	0 = Coasting 1 = Ramping
P2.6.1.3	InhibitDirection	N	0	2	0	1336	0 = Not used 1 = Reverse 2 = Forward
P2.6.1.4	Reference Unit	N	0	1	0	1362	0 = Hz 1 = %
P2.6.1.5	Keypad Reference	Y	0,00 Hz	Max frequency	0,00 Hz	184	See Range
P2.6.1.6	Keypad Direction	Y	0	1	0	123	0 = Forward 1 = Reverse
P2.6.1.7	Keypad Reference copy	Y	0	2	1	181	0 = Copy Run 1 = Copy Ref Run 2 = No Copying
P2.6.1.8	Keypad Stop Button	Y	0	1	1	114	0 = No 1 = Yes
P2.6.1.9	Accel Time 2	Y	0.1 s	3000,0 s	20,0 s	502	See Range
P2.6.1.10	Decel Time 2	Y	0.1 s	3000,0 s	20,0 s	503	See Range
P2.6.1.11	RampselectMode	N	0	1	0	1333	0 = I/O Terminal 1 = Output Frequency
P2.6.1.12	Accel2Threshold	N	0,00 Hz	Max frequency	0,0 Hz	526	See Range
P2.6.1.13	Decel2Threshold	N	0,00 Hz	Max frequency	0,0 Hz	1334	See Range
P2.6.1.14	S-Ramp 1 Shape	N	0,0 s	10,0 s	0,0 s	500	See Range
P2.6.1.15	S-Ramp 2 Shape	N	0,0 s	10,0 s	0,0 s	501	See Range

## Parameters

### Skip Frequencies

Parameter Number	Parameter Name	Change in Run	Min.	Max.	Default	ID	Values
P2.6.2.1	Range 1 Low Lim	N	-1,0 Hz	320,00 Hz	0,00 Hz	509	See Range
P2.6.2.2	Range 1 High Lim	N	0,00 Hz	320,00 Hz	0,00 Hz	510	See Range
P2.6.2.3	Range 2 Low Lim	N	0,00 Hz	320,00 Hz	0,00 Hz	511	See Range
P2.6.2.4	Range 2 High Lim	N	0,00 Hz	320,00 Hz	0,00 Hz	512	See Range
P2.6.2.5	Range 3 Low Lim	N	0,00 Hz	320,00 Hz	0,00 Hz	513	See Range
P2.6.2.6	Range 3 High Lim	N	0,00 Hz	320,00 Hz	0,00 Hz	514	See Range
P2.6.2.7	Range 4 Low Lim	N	0,00 Hz	320,00 Hz	0,00 Hz	1337	See Range
P2.6.2.8	Range 4 High Lim	N	0,00 Hz	320,00 Hz	0,00 Hz	1338	See Range
P2.6.2.9	Range 5 Low Lim	N	0,00 Hz	320,00 Hz	0,00 Hz	1339	See Range
P2.6.2.10	Range 5 High Lim	N	0,00 Hz	320,00 Hz	0,00 Hz	1340	See Range
P2.6.2.11	Range 6 Low Lim	N	0,00 Hz	320,00 Hz	0,00 Hz	1341	See Range
P2.6.2.12	Range 6 High Lim	N	0,00 Hz	320,00 Hz	0,00 Hz	1342	See Range
P2.6.2.13	RampTimeFactor	N	0.1	10,0	1,0	518	See Range

### Motor Control

Parameter Number	Parameter Name	Change in Run	Min.	Max.	Default	ID	Values
P2.7.1	V/Hz RatioSelect	N	0	3	3	108	<b>0</b> = Linear <b>1</b> = Squared <b>2</b> = Programmable <b>3</b> = Active Energy Control
P2.7.2	Field WeakngPnt	N	8,00 Hz	320,00 Hz	P2.1.14	602	See Range
P2.7.3	Voltage at FWP	N	10,0 %	200,0 %	100,0 %	603	See Range
P2.7.4	V/Hz Mid Freq	N	0,00 Hz	P2.1.14	0,00 Hz	604	See Range
P2.7.5	V/Hz Mid Voltage	N	0,00 %	100,00 %	0,00 %	605	See Range
P2.7.6	Zero Freq Voltg	N	0,00 %	40,00 %	0,00 %	606	See Range
P2.7.7	Switching Freq	N	1,5 kHz	10,0 kHz	6,0 kHz	601	See Range

## Protections

### Faults

Parameter Number	Parameter Name	Change in Run	Min.	Max.	Default	ID	Values
P2.8.1.1	AI Low Fault	N	0	4	0	700	0 = No Action 1 = Alarm 2 = Alarm, PresetFreq 3 = Fault 4 = Fault, Coast
P2.8.1.2	Undervoltage Flt	N	0	1	0	727	0 = Fault Stored 1 = No History
P2.8.1.3	OutputPhase Flt	N	0	3	2	702	0 = No Action 1 = Alarm 2 = Fault 3 = Fault, Coast
P2.8.1.4	Motor Duty Cycle	N	0 %	100 %	100 %	708	See Range
P2.8.1.5	Underload Flt	N	0	3	0	713	0 = No Action 1 = Alarm 2 = Fault 3 = Fault, Coast
P2.8.1.6	Motor Therm Prot (options same as Ext. Fault)	N	0	3	2	704	0 = No Action 1 = Alarm 2 = Fault 3 = Fault, Coast
P2.8.1.7	MotAmbient Temp	N	-20,0°C	100,0°C	40,0°C	705	See Range
P2.8.1.8	ZeroSpeedCooling	N	1%	100 %	60 %	706	See Range
P2.8.1.9	ThermTimeConst	N	1 min	200 min	10 min	707	See Range
P2.8.1.10	Thermistor Fault (options same as Ext. Fault)	N	0	3	0	732	0 = No Action 1 = Alarm 2 = Fault 3 = Fault, Coast
P2.8.1.11	External Fault	N	0	3	2	701	0 = No Action 1 = Alarm 2 = Fault 3 = Fault, Coast
P2.8.1.12	FieldbusComm Flt (options same as AI Low Flt)	N	0	4	3	733	0 = No Action 1 = Alarm 2 = Alarm, PresetFreq 3 = Fault 4 = Fault, Coast
P2.8.1.13	InputPhaseFault (options same as Ext. Fault)	N	0	3	3	730	0 = No Action 1 = Alarm 2 = Fault 3 = Fault, Coast
P2.8.1.14	MotorStall Flt	N	0	3	0	709	0 = No Action 1 = Alarm 2 = Fault 3 = Fault, Coast

## Parameters

### Faults, continued

Parameter Number	Parameter Name	Change in Run	Min.	Max.	Default	ID	Values
P2.8.1.15	PID1 Supervision	N	0	3	2	749	0 = No Action 1 = Alarm 2 = Fault 3 = Fault,Coast
P2.8.1.16	PID2 Supervision	N	0	3	2	757	0 = No Action 1 = Alarm 2 = Fault 3 = Fault,Coast
P2.8.1.17	SlotCommFlt	N	0	3	2	734	0 = No Action 1 = Alarm 2 = Fault 3 = Fault,Coast
P2.8.1.18	Preset Alarm Freq	N	Min frequency	Max frequency	25,00 Hz	183	See Range

### Automatic Reset

Parameter Number	Parameter Name	Change in Run	Min.	Max.	Default	ID	Values
P2.8.2.1	Automatic Reset	N	0	3	0	731	0 = Not used 1 = Auto Bypass 2 = Reset faults 3 = Reset/Bypass
P2.8.2.2	Restart function	N	0	1	1	719	0 = Flying Start 1 = Start Function
P2.8.2.3	Wait Time	N	0,00 s	10,00 s	0,50 s	717	See Range
P2.8.2.4	Trial Time	N	0,00 s	10,00 s	10,00 s	718	See Range
P2.8.2.5	Number of trials	N	1	10	4	759	See Range
P2.8.2.6	Undervoltage Flt	N	0	1	1	720	0 = No 1 = Yes
P2.8.2.7	Overvoltage Flt	N	0	1	1	721	0 = No 1 = Yes
P2.8.2.8	Overcurrent Flt	N	0	1	1	722	0 = No 1 = Yes
P2.8.2.9	AI Low Fault	N	0	1	1	723	0 = No 1 = Yes
P2.8.2.10	UnitOverTemp Flt	N	0	1	1	724	0 = No 1 = Yes
P2.8.2.11	MotorOverTempFlt (Yes or No)	N	0	1	1	725	0 = No 1 = Yes
P2.8.2.12	External Fault (Yes or No)	N	0	1	0	726	0 = No 1 = Yes
P2.8.2.13	IGBT temp	N	0	1	0	1358	0 = No 1 = Yes

## PID Controller

### PID Controller 1

#### Basic Settings

Parameter Number	Parameter Name	Change in Run	Min.	Max.	Default	ID	Values
P2.9.1.1.1	Gain, PID Controller 1	Y	0,00 %	200,00 %	100,00 %	118	See Range
P2.9.1.1.2	Integration Time, PID Controller 1	Y	0,00 s	600,00 s	1,00 s	119	See Range
P2.9.1.1.3	Derivation Time, PID Controller 1	Y	0,00 s	100,00 s	0,00 s	132	See Range
P2.9.1.1.4	ProcessUnitSel, PID Controller 1	Y	1	40	1	1036	<b>1</b> = % <b>2</b> = 1/min <b>3</b> = rpm <b>4</b> = ppm <b>5</b> = pps <b>6</b> = l/s <b>7</b> = l/min <b>8</b> = l/h <b>9</b> = kg/s <b>10</b> = kg/min <b>11</b> = kg/h <b>12</b> = m3/s <b>13</b> = m3/min <b>14</b> = m3/h <b>15</b> = m/s <b>16</b> = mbar <b>17</b> = bar <b>18</b> = Pa <b>19</b> = kPa <b>20</b> = mVS <b>21</b> = kW <b>22</b> = °C <b>23</b> = GPM <b>24</b> = gal/s <b>25</b> = gal/min <b>26</b> = gal/h <b>27</b> = lb/s <b>28</b> = lb/min <b>29</b> = lb/h <b>30</b> = CFM <b>31</b> = ft3/s <b>32</b> = ft3/min <b>33</b> = ft3/h <b>34</b> = ft/s <b>35</b> = in wg <b>36</b> = ft wg <b>37</b> = PSI <b>38</b> = lb/in2 <b>39</b> = hp <b>40</b> = F

# Parameters

## Basic Settings, continued

Parameter Number	Parameter Name	Change in Run	Min.	Max.	Default	ID	Values
P2.9.1.1.5	ProcessUnitMin, PID Controller 1	Y	varies	varies	0	1033	See Range
P2.9.1.1.6	ProcessUnitMax, PID Controller 1	Y	varies	varies	100	1034	See Range
P2.9.1.1.7	ProcessUnitDecimals, PID Controller 1	Y	0	4	2	1035	See Range
P2.9.1.1.8	Error Inversion, PID Controller 1	Y	0	1	0	340	<b>0</b> = Normal <b>1</b> = Inverted
P2.9.1.1.9	Dead Band, PID Controller 1	Y	varies	varies	0	1056	See Range
P2.9.1.1.10	Dead band delay, PID Controller 1	Y	0,00 s	320,00 s	0,00 s	1057	See Range

## Setpoints

Parameter Number	Parameter Name	Change in Run	Min.	Max.	Default	ID	Values
P2.9.1.2.1	Keypad SP 1, PID Controller 1	Y	varies	varies	0	167	See Range
P2.9.1.2.2	Keypad SP 2, PID Controller 1	Y	varies	varies	0	168	See Range
P2.9.1.2.3	Ramp Time, PID Controller 1	Y	0,00 s	300,0 s	0,00 s	1068	See Range
P2.9.1.2.4	SetPt 1 Source, PID Controller 1	Y	0	16	1	332	<b>0</b> = Not used <b>1</b> = Keypad SP 1 <b>2</b> = Keypad SP 2 <b>3</b> = AI1 <b>4</b> = AI2 <b>5</b> = AI3 <b>6</b> = AI4 <b>7</b> = AI5 <b>8</b> = AI6 <b>9</b> = ProcessDataIn1 <b>10</b> = ProcessDataIn2 <b>11</b> = ProcessDataIn3 <b>12</b> = ProcessDataIn4 <b>13</b> = ProcessDataIn5 <b>14</b> = ProcessDataIn6 <b>15</b> = ProcessDataIn7 <b>16</b> = ProcessDataIn8
P2.9.1.2.5	SetPt 1 min, PID Controller 1	Y	-200,00 %	200,00 %	0,00 %	1069	See Range
P2.9.1.2.6	SP 1 maximum, PID Controller 1	Y	-200,00 %	200,00 %	100,00 %	1070	See Range
P2.9.1.2.7	SP 1 Sleep Freq, PID Controller 1	Y	0,00 Hz	320,00 Hz	0,00 Hz	1016	See Range
P2.9.1.2.8	SP 1 Sleep delay, PID Controller 1	Y	0 s	3000 s	0 s	1017	See Range
P2.9.1.2.9	SP 1 WakeUpLevel, PID Controller 1	Y	-214748.35	214748.35	0,00	1018	See Range



## Setpoints, continued

Parameter Number	Parameter Name	Change in Run	Min.	Max.	Default	ID	Values
P2.9.1.2.10	SP 1 boost, PID Controller 1	Y	-2,0 x	2,0 x	1,0 x	1071	See Range
P2.9.1.2.11	SP 2 Source, PID Controller 1 (see the list of SP1 source)	Y	0	16	2	431	<b>0</b> = Not used <b>1</b> = Keypad SP 1 <b>2</b> = Keypad SP 2 <b>3</b> = AI1 <b>4</b> = AI2 <b>5</b> = AI3 <b>6</b> = AI4 <b>7</b> = AI5 <b>8</b> = AI6 <b>9</b> = ProcessDataIn1 <b>10</b> = ProcessDataIn2 <b>11</b> = ProcessDataIn3 <b>12</b> = ProcessDataIn4 <b>13</b> = ProcessDataIn5 <b>14</b> = ProcessDataIn6 <b>15</b> = ProcessDataIn7 <b>16</b> = ProcessDataIn8
P2.9.1.2.12	SP 2 minimum, PID Controller 1	Y	-200,00 %	200,00 %	0,00 %	1073	See Range
P2.9.1.2.13	SP 2 maximum, PID Controller 1	Y	-200,00 %	200,00 %	100,00 %	1074	See Range
P2.9.1.2.14	SP 2 Sleep Freq, PID Controller 1	Y	0,00 Hz	320,00 Hz	0,00 Hz	1075	See Range
P2.9.1.2.15	SP 2 Sleep delay, PID Controller 1	Y	0 s	3000 s	0 s	1076	See Range
P2.9.1.2.16	SP 2 WakeUpLevel, PID Controller 1	Y	-214748.35	214748.35	0,00	1077	See Range
P2.9.1.2.17	SP 2 boost, PID Controller 1	Y	-2,0 x	2,0 x	1,0 x	1078	See Range

# Parameters

## Feedbacks

Parameter Number	Parameter Name	Change in Run	Min.	Max.	Default	ID	Values
P2.9.1.3.1	Function, PID Controller 1	Y	1	9	1	333	<b>1</b> = Source 1 <b>2</b> = SQRT(Source1) <b>3</b> = SQRT(Source1- Source 2) <b>4</b> = SQRT(Source 1) + SQRT(Source 2) <b>5</b> = Source 1 + Source 2 <b>6</b> = Source 1 - Source 2 <b>7</b> = MIN (Source 1, Source 2) <b>8</b> = MAX (Source 1, Source 2) <b>9</b> = MEAN (Source 1, Source 2)
P2.9.1.3.2	Gain, PID Controller 1	Y	-1000,0 %	1000,0 %	100,0 %	1058	See Range
P2.9.1.3.3	FeedBack 1 Srce, PID Controller 1	Y	0	14	1	334	<b>0</b> = Not used <b>1</b> = AI1 <b>2</b> = AI2 <b>3</b> = AI3 <b>4</b> = AI4 <b>5</b> = AI5 <b>6</b> = AI6 <b>7</b> = ProcessDataIn1 <b>8</b> = ProcessDataIn2 <b>9</b> = ProcessDataIn3 <b>10</b> = ProcessDataIn4 <b>11</b> = ProcessDataIn5 <b>12</b> = ProcessDataIn6 <b>13</b> = ProcessDataIn7 <b>14</b> = ProcessDataIn8
P2.9.1.3.4	FB 1 Minimum, PID Controller 1	Y	-200,0 %	200,0 %	0,00 %	336	See Range
P2.9.1.3.5	FB 1 Maximum, PID Controller 1	Y	-200,0 %	200,0 %	100,0 %	337	See Range
P2.9.1.3.6	FB 2 Source, PID Controller 1 (see the options of FB 1 source)	Y	0	14	0	335	<b>0</b> = Not used <b>1</b> = AI1 <b>2</b> = AI2 <b>3</b> = AI3 <b>4</b> = AI4 <b>5</b> = AI5 <b>6</b> = AI6 <b>7</b> = ProcessDataIn1 <b>8</b> = ProcessDataIn2 <b>9</b> = ProcessDataIn3 <b>10</b> = ProcessDataIn4 <b>11</b> = ProcessDataIn5 <b>12</b> = ProcessDataIn6 <b>13</b> = ProcessDataIn7 <b>14</b> = ProcessDataIn8
P2.9.1.3.7	FB 2 Minimum, PID Controller 1	Y	-200,0 %	200,0 %	0,00 %	338	See Range
P2.9.1.3.8	FB 2 Maximum, PID Controller 1	Y	-200,0 %	200,0 %	100,0 %	339	See Range

**Feedforward**

Parameter Number	Parameter Name	Change in Run	Min.	Max.	Default	ID	Values
P2.9.1.4.1	Function, PID Controller 1	Y	1	9	1	1059	<b>1</b> = Source 1 <b>2</b> = SQRT(Source1) <b>3</b> = SQRT(Source1- Source 2) <b>4</b> = SQRT(Source 1) + SQRT(Source 2) <b>5</b> = Source 1 + Source 2 <b>6</b> = Source 1 - Source 2 <b>7</b> = MIN (Source 1, Source 2) <b>8</b> = MAX (Source 1, Source 2) <b>9</b> = MEAN (Source 1, Source 2)
P2.9.1.4.2	Gain, PID Controller 1	Y	-1000,0 %	1000,0 %	100,0 %	1060	See Range
P2.9.1.4.3	FF 1 Source, PID Controller 1	Y	0	14	0	1061	<b>0</b> = Not used <b>1</b> = AI1 <b>2</b> = AI2 <b>3</b> = AI3 <b>4</b> = AI4 <b>5</b> = AI5 <b>6</b> = AI6 <b>7</b> = ProcessDataIn1 <b>8</b> = ProcessDataIn2 <b>9</b> = ProcessDataIn3 <b>10</b> = ProcessDataIn4 <b>11</b> = ProcessDataIn5 <b>12</b> = ProcessDataIn6 <b>13</b> = ProcessDataIn7 <b>14</b> = ProcessDataIn8
P2.9.1.4.4	FF1 Minimum, PID Controller 1	Y	-200,0 %	200,0 %	0,00 %	1062	See Range
P2.9.1.4.5	FF1 Maximum, PID Controller 1	Y	-200,0 %	200,0 %	100,0 %	1063	See Range
P2.9.1.4.6	FF 2 Source, PID Controller 1	Y	1	9	0	1064	<b>0</b> = Not used <b>1</b> = AI1 <b>2</b> = AI2 <b>3</b> = AI3 <b>4</b> = AI4 <b>5</b> = AI5 <b>6</b> = AI6 <b>7</b> = ProcessDataIn1 <b>8</b> = ProcessDataIn2 <b>9</b> = ProcessDataIn3 <b>10</b> = ProcessDataIn4 <b>11</b> = ProcessDataIn5 <b>12</b> = ProcessDataIn6 <b>13</b> = ProcessDataIn7 <b>14</b> = ProcessDataIn8
P2.9.1.4.7	FF2 Minimum, PID Controller 1	Y	-200,0 %	200,0 %	0,00 %	1065	See Range
P2.9.1.4.8	FF2 Maximum, PID Controller 1	Y	-200,0 %	200,0 %	100,0 %	1066	See Range

## Parameters

### Process Supervision

Parameter Number	Parameter Name	Change in Run	Min.	Max.	Default	ID	Values
P2.9.1.5.1	Enable Superv, PID Controller 1	Y	0	1	0	735	<b>0</b> = Disabled <b>1</b> = Enabled
P2.9.1.5.2	Upper limit, PID Controller 1	Y	-214748.35%	214748.35%	0 %	736	See Range
P2.9.1.5.3	Lower limit, PID Controller 1	Y	-214748.35%	214748.35%	0 %	758	See Range
P2.9.1.5.4	Delay, PID Controller 1	Y	0 s	30000 s	0 s	737	See Range

### Pressure Loss Compensation

Parameter Number	Parameter Name	Change in Run	Min.	Max.	Default	ID	Values
P2.9.1.6.1	Enable SP 1, PID Controller 1	Y	0	1	0	1529	<b>0</b> = Disabled <b>1</b> = Enabled
P2.9.1.6.2	SP 1 Max Comp., PID Controller 1	Y	-214748.35%	214748.35%	0 %	1530	See Range
P2.9.1.6.3	Enable SP 2, PID Controller 1	Y	0	1	0	1531	<b>0</b> = Disabled <b>1</b> = Enabled
P2.9.1.6.4	SP 2 Max Comp., PID Controller 1	Y	-214748.35%	214748.35%	0 %	1532	See Range

## PID Controller 2

### Basic Settings

Parameter Number	Parameter Name	Change in Run	Min.	Max.	Default	ID	Values
P2.9.2.1.1	Gain, PID Controller 2	Y	0,00 %	200,00 %	100,00 %	1631	See Range
P2.9.2.1.2	Integration Time, PID Controller 2	Y	0,00 s	600,00 s	1,00 s	1632	See Range
P2.9.2.1.3	Derivation Time, PID Controller 2	Y	0,00 s	100,00 s	0,00 s	1633	See Range
P2.9.2.1.4	ProcessUnitSel, PID Controller 2	Y	1	40	1	1635	<b>1</b> = % <b>2</b> = 1/min <b>3</b> = rpm <b>4</b> = ppm <b>5</b> = pps <b>6</b> = l/s <b>7</b> = l/min <b>8</b> = l/h <b>9</b> = kg/s <b>10</b> = kg/min <b>11</b> = kg/h <b>12</b> = m3/s <b>13</b> = m3/min <b>14</b> = m3/h <b>15</b> = m/s <b>16</b> = mbar <b>17</b> = bar <b>18</b> = Pa <b>19</b> = kPa <b>20</b> = mVS <b>21</b> = kW <b>22</b> = °C <b>23</b> = GPM <b>24</b> = gal/s <b>25</b> = gal/min <b>26</b> = gal/h <b>27</b> = lb/s <b>28</b> = lb/min <b>29</b> = lb/h <b>30</b> = CFM <b>31</b> = ft3/s <b>32</b> = ft3/min <b>33</b> = ft3/h <b>34</b> = ft/s <b>35</b> = in wg <b>36</b> = ft wg <b>37</b> = PSI <b>38</b> = lb/in2 <b>39</b> = hp <b>40</b> = F

# Parameters

## Basic Settings, continued

Parameter Number	Parameter Name	Change in Run	Min.	Max.	Default	ID	Values
P2.9.2.1.5	ProcessUnitMin, PID Controller 2	Y	varies	varies	0	1664	See Range
P2.9.2.1.6	ProcessUnitMax, PID Controller 2	Y	varies	varies	100	1665	See Range
P2.9.2.1.7	ProcessUnitDecimals, PID Controller 2	Y	0	4	2	1666	See Range
P2.9.2.1.8	Error Inversion, PID Controller 2	Y	0	1	0	1636	<b>0</b> = Normal <b>1</b> = Inverted
P2.9.2.1.9	Dead Band, PID Controller 2	Y	varies	varies	0	1637	See Range
P2.9.2.1.10	Dead band delay, PID Controller 2	Y	0,00 s	320,00 s	0,00 s	1638	See Range

## Setpoints

Parameter Number	Parameter Name	Change in Run	Min.	Max.	Default	ID	Values
P2.9.2.2.1	Keypad SP 1, PID Controller 2	Y	varies	varies	0	1640	See Range
P2.9.2.2.2	Keypad SP 2, PID Controller 2	Y	varies	varies	0	1641	See Range
P2.9.2.2.3	Ramp Time, PID Controller 2	Y	0,00 s	300,0 s	0,00 s	1642	See Range
P2.9.2.2.4	SetPt 1 Source, PID Controller 2	Y	0	16	1	1643	<b>0</b> = Not used <b>1</b> = Keypad SP 1 <b>2</b> = Keypad SP 2 <b>3</b> = AI1 <b>4</b> = AI2 <b>5</b> = AI3 <b>6</b> = AI4 <b>7</b> = AI5 <b>8</b> = AI6 <b>9</b> = ProcessDataIn1 <b>10</b> = ProcessDataIn2 <b>11</b> = ProcessDataIn3 <b>12</b> = ProcessDataIn4 <b>13</b> = ProcessDataIn5 <b>14</b> = ProcessDataIn6 <b>15</b> = ProcessDataIn7 <b>16</b> = ProcessDataIn8
P2.9.2.2.5	SetPt 1 min, PID Controller 2	Y	-200,00 %	200,00 %	0,00 %	1644	See Range
P2.9.2.2.6	SP 1 maximum, PID Controller 2	Y	-200,00 %	200,00 %	100,00 %	1645	See Range

## Setpoints, continued

Parameter Number	Parameter Name	Change in Run	Min.	Max.	Default	ID	Values
P2.9.2.2.7	SP 2 Source, PID Controller 2 (see the list of SP1 source)	Y	0	16	2	1646	<b>0</b> = Not used <b>1</b> = Keypad SP 1 <b>2</b> = Keypad SP 2 <b>3</b> = AI1 <b>4</b> = AI2 <b>5</b> = AI3 <b>6</b> = AI4 <b>7</b> = AI5 <b>8</b> = AI6 <b>9</b> = ProcessDataIn1 <b>10</b> = ProcessDataIn2 <b>11</b> = ProcessDataIn3 <b>12</b> = ProcessDataIn4 <b>13</b> = ProcessDataIn5 <b>14</b> = ProcessDataIn6 <b>15</b> = ProcessDataIn7 <b>16</b> = ProcessDataIn8
P2.9.2.2.8	SP 2 minimum, PID Controller 2	Y	-200,00 %	200,00 %	0,00 %	1647	See Range
P2.9.2.2.9	SP 2 maximum, PID Controller 2	Y	-200,00 %	200,00 %	100,00 %	1648	See Range

## Feedbacks

Parameter Number	Parameter Name	Change in Run	Min.	Max.	Default	ID	Values
P2.9.2.3.1	Function, PID Controller 2	Y	1	9	1	1650	<b>1</b> = Source 1 <b>2</b> = SQRT (Source1) <b>3</b> = SQRT (Source1 -Source 2) <b>4</b> = SQRT (Source 1) + SQRT (Source 2) <b>5</b> = Source 1 + Source 2 <b>6</b> = Source 1 -Source 2 <b>7</b> = MIN (Source 1, Source 2) <b>8</b> = MAX (Source 1, Source 2) <b>9</b> = MEAN (Source 1, Source 2)
P2.9.2.3.2	Gain, PID Controller 2	Y	-1000,0 %	1000,0 %	100,0 %	1651	See Range
P2.9.2.3.3	FeedBack 1 Srce, PID Controller 2	Y	0	14	1	1652	<b>0</b> = Not used <b>1</b> = AI1 <b>2</b> = AI2 <b>3</b> = AI3 <b>4</b> = AI4 <b>5</b> = AI5 <b>6</b> = AI6 <b>7</b> = ProcessDataIn1 <b>8</b> = ProcessDataIn2 <b>9</b> = ProcessDataIn3 <b>10</b> = ProcessDataIn4 <b>11</b> = ProcessDataIn5 <b>12</b> = ProcessDataIn6 <b>13</b> = ProcessDataIn7 <b>14</b> = ProcessDataIn8
P2.9.2.3.4	FB 1 Minimum, PID Controller 2	Y	-200,0 %	200,0 %	0,00 %	1653	See Range

## Parameters

### Feedbacks, continued

Parameter Number	Parameter Name	Change in Run	Min.	Max.	Default	ID	Values
P2.9.2.3.5	FB 1 Maximum, PID Controller 2	Y	-200,0 %	200,0 %	100,0 %	1654	See Range
P2.9.2.3.6	FB 2 Source, PID Controller 2 (see the options of FB 1 source)	Y	0	14	0	1655	<b>0</b> = Not used <b>1</b> = AI1 <b>2</b> = AI2 <b>3</b> = AI3 <b>4</b> = AI4 <b>5</b> = AI5 <b>6</b> = AI6 <b>7</b> = ProcessDataIn1 <b>8</b> = ProcessDataIn2 <b>9</b> = ProcessDataIn3 <b>10</b> = ProcessDataIn4 <b>11</b> = ProcessDataIn5 <b>12</b> = ProcessDataIn6 <b>13</b> = ProcessDataIn7 <b>14</b> = ProcessDataIn8
P2.9.2.3.7	FB 2 Minimum, PID Controller 2	Y	-200,0 %	200,0 %	0,00 %	1656	See Range
P2.9.2.3.8	FB 2 Maximum, PID Controller 2	Y	-200,0 %	200,0 %	100,0 %	1657	See Range

### Process Supervision

Parameter Number	Parameter Name	Change in Run	Min.	Max.	Default	ID	Values
P2.9.2.4.1	Enable Superv, PID Controller 2	Y	0	1	0	1659	<b>0</b> = Disabled <b>1</b> = Enabled
P2.9.2.4.2	Upper limit, PID Controller 2	Y	-214748.35%	214748.35%	0 %	1660	See Range
P2.9.2.4.3	Lower limit, PID Controller 2	Y	-214748.35%	214748.35%	0 %	1661	See Range
P2.9.2.4.4	Delay, PID Controller 2	Y	0 s	30000 s	0 s	1662	See Range

### Fixed Frequencies

Parameter Number	Parameter Name	Change in Run	Min.	Max.	Default	ID	Values
P2.10.1	Preset Freq 1	Y	0,00 Hz	Max frequency	10,00 Hz	105	See Range
P2.10.2	Preset Freq 2	Y	0,00 Hz	Max frequency	15,00 Hz	106	See Range
P2.10.3	Preset Freq 3	Y	0,00 Hz	Max frequency	20,00 Hz	126	See Range
P2.10.4	Preset Freq 4	Y	0,00 Hz	Max frequency	25,00 Hz	127	See Range
P2.10.5	Preset Freq 5	Y	0,00 Hz	Max frequency	30,00 Hz	128	See Range
P2.10.6	Preset Freq 6	Y	0,00 Hz	Max frequency	40,00 Hz	129	See Range
P2.10.7	Preset Freq 7	Y	0,00 Hz	Max frequency	50,00 Hz	130	See Range



**Fire Mode**

Parameter Number	Parameter Name	Change in Run	Min.	Max.	Default	ID	Values
P2.11.1	Firemode Freq	Y	0,00 Hz	Max frequency	50,00 Hz / 60,00 Hz	1598	See Range

**Multi-Pump**

Parameter Number	Parameter Name	Change in Run	Min.	Max.	Default	ID	Values
P2.12.1	Number of motors	Y	1	4	1	1001	See Range
P2.12.2	Interlock function	Y	0	1	1	1032	0 = Disabled 1 = Enabled
P2.12.3	Include FC	Y	0	1	1	1028	0 = Disabled 1 = Enabled
P2.12.4	Autochange	Y	0	1	0	1027	0 = Disabled 1 = Enabled
P2.12.5	Autochange interval	Y	0,0 hr	3000,0 hr	48,0 hr	1029	See Range
P2.12.6	Autochange: frequency limit	Y	Min frequency	Max frequency	25,0 Hz	1031	See Range
P2.12.7	Autochange: motor limit	Y	0	4	1	1030	See Range
P2.12.8	Bandwidth	Y	0,0 %	100,0 %	10,0 %	1097	See Range
P2.12.9	Bandwidth delay	Y	0 s	3600 s	10 s	1098	See Range

**Braking**

Parameter Number	Parameter Name	Change in Run	Min.	Max.	Default	ID	Values
P2.13.1	DC Brake Current (when stopping)	N	varies	varies	varies	507	See Range
P2.13.2	DC Time Stop	N	0,00 s	600,00 s	0,00 s	508	See Range
P2.13.3	DC BrakeFreqStop	N	0.10 Hz	10,00 Hz	1,50 Hz	515	See Range
P2.13.4	StartMagnTime	N	0,00 s	600,00 s	0,00 s	516	See Range
P2.13.5	StartMagnCurrent	N	varies	varies	varies	517	See Range
P2.13.6	Preheat Current (via digital input)	N	0,00 A	0,2/Nom current	0,00 A	1335	See Range

## Parameters

### Fieldbus

Parameter Number	Parameter Name	Change in Run	Min.	Max.	Default	ID	Values
P2.14.1	FB Data Out1 Sel	Y	0	35000	1	852	Update
P2.14.2	FB Data Out2 Sel	Y	0	35000	2	853	Update
P2.14.3	FB Data Out3 Sel	Y	0	35000	3	854	Update
P2.14.4	FB Data Out4 Sel	Y	0	35000	4	855	Update
P2.14.5	FB Data Out5 Sel	Y	0	35000	5	856	Update
P2.14.6	FB Data Out6 Sel	Y	0	35000	6	857	Update
P2.14.7	FB Data Out7 Sel	Y	0	35000	7	858	Update
P2.14.8	FB Data Out8 Sel	Y	0	35000	37	859	Update

### Second Param Set

#### Motor 2

Parameter Number	Parameter Name	Change in Run	Min.	Max.	Default	ID	Values
P2.15.1.1	Motor Nom Currnt, Set2	N	varies	varies	varies	1347	See Range
P2.15.1.2	Motor Nom Voltg, Set2	N	180,0 V	690,0 V	varies	1348	See Range
P2.15.1.3	Motor Nom Freq, Set2	N	8,00 Hz	320,00 Hz	50,00 / 60,00	1349	See Range
P2.15.1.4	Motor Nom Speed, Set2	N	24 rpm	19200 rpm	1440 EU / 1750 US	1350	See Range
P2.15.1.5	MotorPowerFactor, Set2	N	0,30	1,00	0,74	1351	See Range
P2.15.1.6	Current Limit, Set2	N	varies	varies	varies	1352	See Range
P2.15.1.7	Motor Therm Prot, Set2 (see options from Protections)	N	0	3	2	1353	<b>0</b> = No Action <b>1</b> = Alarm <b>2</b> = Fault <b>3</b> = Fault,Coast

#### Drive Control 2

Parameter Number	Parameter Name	Change in Run	Min.	Max.	Default	ID	Values
P2.15.2.1	Min Frequency, Set2	Y	0,00 Hz	Max frequency	12,00 Hz	1343	See Range
P2.15.2.2	Max Frequency, Set2	Y	Min frequency	320,00 Hz	50,00 / 60,00	1344	See Range
P2.15.2.3	Accel Time 1, Set2	Y	0.1 s	3000,0 s	60,0 s	1345	See Range
P2.15.2.4	Decel Time 1, Set2	Y	0.1 s	3000,0 s	60,0 s	1346	See Range
P2.15.2.5	V/Hz RatioSelect, Set2	N	0	3	3	1355	<b>0</b> = Linear <b>1</b> = Squared <b>2</b> = Programmable <b>2</b> = Active Energy Control

## Timer Functions

### Interval 1

Parameter Number	Parameter Name	Change in Run	Min.	Max.	Default	ID	Values
P2.16.1.1	ON Time, Interval 1	Y	00:00:00	23:59:59	0:00:00	1670	See Range
P2.16.1.2	Off Time, Interval 1	Y	00:00:00	23:59:59	0:00:00	1671	See Range
P2.16.1.3	From Day, Interval 1	Y	0	6	0	1672	<b>0</b> = Sunday <b>1</b> = Monday <b>2</b> = Tuesday <b>3</b> = Wednesday <b>4</b> = Thursday <b>5</b> = Friday <b>6</b> = Saturday
P2.16.1.4	To Day, Interval 1 (see above)	Y	0	6	0	1673	<b>0</b> = Sunday <b>1</b> = Monday <b>2</b> = Tuesday <b>3</b> = Wednesday <b>4</b> = Thursday <b>5</b> = Friday <b>6</b> = Saturday
P2.16.1.5	Assign to channel, Interval 1	Y	0	3	0	1674	<b>0</b> = Not used <b>1</b> = Time channel 1 <b>2</b> = Time channel 2 <b>3</b> = Time channel 3

### Interval 2

Parameter Number	Parameter Name	Change in Run	Min.	Max.	Default	ID	Values
P2.16.2.1	ON Time, Interval 2	Y	00:00:00	23:59:59	0:00:00	1675	See Range
P2.16.2.2	Off Time, Interval 2	Y	00:00:00	23:59:59	0:00:00	1676	See Range
P2.16.2.3	From Day, Interval 2	Y	0	6	0	1677	<b>0</b> = Sunday <b>1</b> = Monday <b>2</b> = Tuesday <b>3</b> = Wednesday <b>4</b> = Thursday <b>5</b> = Friday <b>6</b> = Saturday
P2.16.2.4	To Day, Interval 2 (see above)	Y	0	6	0	1678	<b>0</b> = Sunday <b>1</b> = Monday <b>2</b> = Tuesday <b>3</b> = Wednesday <b>4</b> = Thursday <b>5</b> = Friday <b>6</b> = Saturday
P2.16.2.5	Assign to channel, Interval 2	Y	0	3	0	1679	<b>0</b> = Not used <b>1</b> = Time channel 1 <b>2</b> = Time channel 2 <b>3</b> = Time channel 3

## Parameters

### Interval 3

Parameter Number	Parameter Name	Change in Run	Min.	Max.	Default	ID	Values
P2.16.3.1	ON Time, Interval 3	Y	00:00:00	23:59:59	0:00:00	1680	See Range
P2.16.3.2	Off Time, Interval 3	Y	00:00:00	23:59:59	0:00:00	1681	See Range
P2.16.3.3	From Day, Interval 3	Y	0	6	0	1682	<b>0</b> = Sunday <b>1</b> = Monday <b>2</b> = Tuesday <b>3</b> = Wednesday <b>4</b> = Thursday <b>5</b> = Friday <b>6</b> = Saturday
P2.16.3.4	To Day, Interval 3 (see above)	Y	0	6	0	1683	<b>0</b> = Sunday <b>1</b> = Monday <b>2</b> = Tuesday <b>3</b> = Wednesday <b>4</b> = Thursday <b>5</b> = Friday <b>6</b> = Saturday
P2.16.3.5	Assign to channel, Interval 3	Y	0	3	0	1684	<b>0</b> = Not used <b>1</b> = Time channel 1 <b>2</b> = Time channel 2 <b>3</b> = Time channel 3

### Interval 4

Parameter Number	Parameter Name	Change in Run	Min.	Max.	Default	ID	Values
P2.16.4.1	ON Time, Interval 4	Y	00:00:00	23:59:59	0:00:00	1685	See Range
P2.16.4.2	Off Time, Interval 4	Y	00:00:00	23:59:59	0:00:00	1686	See Range
P2.16.4.3	From Day, Interval 4	Y	0	6	0	1687	<b>0</b> = Sunday <b>1</b> = Monday <b>2</b> = Tuesday <b>3</b> = Wednesday <b>4</b> = Thursday <b>5</b> = Friday <b>6</b> = Saturday
P2.16.4.4	To Day, Interval 4 (see above)	Y	0	6	0	1688	<b>0</b> = Sunday <b>1</b> = Monday <b>2</b> = Tuesday <b>3</b> = Wednesday <b>4</b> = Thursday <b>5</b> = Friday <b>6</b> = Saturday
P2.16.4.5	Assign to channel, Interval 4	Y	0	3	0	1689	<b>0</b> = Not used <b>1</b> = Time channel 1 <b>2</b> = Time channel 2 <b>3</b> = Time channel 3

## Interval 5

Parameter Number	Parameter Name	Change in Run	Min.	Max.	Default	ID	Values
P2.16.5.1	ON Time, Interval 5	Y	00:00:00	23:59:59	0:00:00	1690	See Range
P2.16.5.2	Off Time, Interval 5	Y	00:00:00	23:59:59	0:00:00	1691	See Range
P2.16.5.3	From Day, Interval 5	Y	0	6	0	1692	0 = Sunday 1 = Monday 2 = Tuesday 3 = Wednesday 4 = Thursday 5 = Friday 6 = Saturday
P2.16.5.4	To Day, Interval 5 (see above)	Y	0	6	0	1693	0 = Sunday 1 = Monday 2 = Tuesday 3 = Wednesday 4 = Thursday 5 = Friday 6 = Saturday
P2.16.5.5	Assign to channel, Interval 5	Y	0	3	0	1694	0 = Not used 1 = Time channel 1 2 = Time channel 2 3 = Time channel 3

## Timer 1

Parameter Number	Parameter Name	Change in Run	Min.	Max.	Default	ID	Values
P2.16.6.1	Duration	Y	0 s	72000 s	0 s	1695	See Range
P2.16.6.2	Assign to channel	Y	0	3	0	1696	0 = Not used 1 = Time channel 1 2 = Time channel 2 3 = Time channel 3

## Timer 2

Parameter Number	Parameter Name	Change in Run	Min.	Max.	Default	ID	Values
P2.16.7.1	Duration	Y	0 s	72000 s	0 s	1697	See Range
P2.16.7.2	Assign to channel (see above)	Y	0	3	0	1698	0 = Not used 1 = Time channel 1 2 = Time channel 2 3 = Time channel 3

## Timer 3

Parameter Number	Parameter Name	Change in Run	Min.	Max.	Default	ID	Values
P2.16.8.1	Duration	Y	0 s	72000 s	0 s	1699	See Range
P2.16.8.2	Assign to channel (see above)	Y	0	3	0	1700	0 = Not used 1 = Time channel 1 2 = Time channel 2 3 = Time channel 3

## I/O and Hardware

### Basic I/O

#### Basic Parameters

Parameter Number	Parameter Name	Unit	ID	Description
<b>M4.1.1</b>	<b>Digital Input 1</b>	Binary	N/A	State of digital input signal <b>0</b> = Off <b>1</b> = On
<b>M4.1.2</b>	<b>Digital Input 2</b>	Binary	N/A	State of digital input signal <b>0</b> = Off <b>1</b> = On
<b>M4.1.3</b>	<b>Digital Input 3</b>	Binary	N/A	State of digital input signal <b>0</b> = Off <b>1</b> = On
<b>M4.1.4</b>	<b>Digital Input 4</b>	Binary	N/A	State of digital input signal <b>0</b> = Off <b>1</b> = On
<b>M4.1.5</b>	<b>Digital Input 5</b>	Binary	N/A	State of digital input signal <b>0</b> = Off <b>1</b> = On
<b>M4.1.6</b>	<b>Digital Input 6</b>	Binary	N/A	State of digital input signal <b>0</b> = Off <b>1</b> = On
<b>M4.1.7</b>	<b>Analog Input 1 Mode</b>	Units	N/A	Mode of analog input signal
<b>M4.1.8</b>	<b>Analog Input 1</b>	%	N/A	State of analog input signal
<b>M4.1.9</b>	<b>Analog Input 2 Mode</b>	Units	N/A	Mode of analog input signal
<b>M4.1.10</b>	<b>Analog Input 2</b>	%	N/A	State of analog input signal
<b>M4.1.11</b>	<b>Analog Output 1 Mode</b>	Units	N/A	Mode of analog output signal
<b>M4.1.12</b>	<b>Analog Output 1</b>	%	N/A	State of analog output signal
<b>M4.1.13</b>	<b>Relay Output 1</b>	Binary	N/A	State of digital output signal <b>0</b> = Off <b>1</b> = On
<b>M4.1.14</b>	<b>Relay Output 2</b>	Binary	N/A	State of digital output signal <b>0</b> = Off <b>1</b> = On
<b>M4.1.15</b>	<b>Relay Output 3</b>	Binary	N/A	State of digital output signal <b>0</b> = Off <b>1</b> = On

**Real-Time Clock**

Parameter Number	Parameter Name	Unit	ID	Description
M4.4.1	Battery state	Numeric	2205	Status of battery <b>1</b> = Not installed <b>2</b> = Installed <b>3</b> = Need to change

Parameter Number	Parameter Name	Change In Run	Min.	Max.	Default	ID	Description
P4.4.2	Time	Y	xx:xx:xx	xx:xx:xx	—	2201	See Range
P4.4.3	Date	Y	xx.xx	xx.xx	2011	2202	See Range
P4.4.4	Year	Y	2011	9999	2011	2203	See Range
P4.4.5	Daylight saving	Y	1	4	3	2204	<b>1</b> = Off <b>2</b> = EU <b>3</b> = US <b>4</b> = Russia

**Power Unit Settings****Fan Control**

Parameter Number	Parameter Name	Unit	ID	Description
M4.5.1.2	Fan speed	%	848	Fan Speed Percentage

Parameter Number	Parameter Name	Change In Run	Min.	Max.	Default	ID	Description
P4.5.1.3	Fan Stop	Y	0	1	Binary	826	<b>1</b> = Disabled <b>2</b> = Enabled

**Sine Filter**

Parameter Number	Parameter Name	Change In Run	Min.	Max.	Default	ID	Description
P4.5.4.1	Sine filter	Y	0	1	Text	N/A	<b>1</b> = Disabled <b>2</b> = Enabled

**Keypad**

Parameter Number	Parameter Name	Change In Run	Min.	Max.	Default	ID	Description
P4.6.1	Time Out Time	Y	0 min.	60 min	1 min	N/A	See Range
P4.6.2	Default Page	Y	0	4	3	N/A	<b>0</b> = None <b>1</b> = Enter Menu Index <b>2</b> = Main Menu <b>3</b> = Control Page <b>4</b> = MultiMonitor
P4.6.3	Menu Index	Y	0 sec.	255 sec.	0	N/A	See Range
P4.6.4	Contrast	Y	30%	70%	40%	N/A	See Range
P4.6.5	Backlight Time	Y	0 min.	60 min	5 min	N/A	See Range

## Common Settings

### RS-485

Parameter Number	Parameter Name	Change In Run	Min.	Max.	Default	ID	Description
P4.7.1.1	Protocol	N	0	3	Binary	2208	<b>0</b> = No Protocol <b>1</b> = ModBus RTU <b>2</b> = N2 <b>3</b> = BACnet MSTP

### Ethernet

Parameter Number	Parameter Name	Change In Run	Min.	Max.	Default	ID	Description
P4.8.1.1	IP Address Mode	N	1	2	1	N/A	<b>1</b> = DHCP with Auto IP <b>2</b> = Fixed IP
P4.8.1.2	IP Address	N	0	255	0	N/A	See Range
P4.8.1.3	Subnet Mask	N	0	255	0	N/A	See Range
P4.8.1.4	Default Gateway	N	0	255	0	N/A	See Range

Parameter Number	Parameter Name	Unit	ID	Description
M 4.8.1.5	MAC Address	N/A	N/A	MAC Address

### Modbus TCP

Parameter Number	Parameter Name	Change In Run	Min.	Max.	Default	ID	Description
P4.8.2.1.1	Connection limit	N	0	2	0	N/A	See Range
P4.8.2.1.2	Slave address	N	0	255	0	N/A	See Range
P4.8.2.1.3	Comm. Timeout	N	0 sec	65535 sec	10 sec	N/A	See Range

### BACnet IP

Parameter Number	Parameter Name	Change In Run	Min.	Max.	Default	ID	Description
P4.8.3.1.1	Instance Number	N	0	65535	0	N/A	See Range
P4.8.3.1.2	Comm. Timeout	N	0	65535	0	N/A	See Range
P4.8.3.1.3	Protocol in use	N	0	1	0	N/A	See Range
P4.8.3.1.4	BBMD IP	N	0	255	0	N/A	See Range
P4.8.3.1.5	BBMD Port	N	1	65535	0	N/A	See Range
P4.8.3.1.6	Time to live	N	0	255	0	N/A	See Range

## Monitoring

### Monitoring

Parameter Number	Parameter Name	Unit	ID	Description
M 4.8.3.2.1	FB Protocol Status	N/A	N/A	FB Protocol Status
M 4.8.3.2.2	Comm. Status	N/A	N/A	Comm. Status
M 4.8.3.2.3	Actual Instance	N/A	N/A	Actual Instance
M 4.8.3.2.4	Control Word	N/A	N/A	Control Word
M 4.8.3.2.5	Status Word	N/A	N/A	Status Word



## User Settings

### User Settings

Parameter Number	Parameter Name	Change In Run	Min.	Max.	Default	ID	Description
<b>P 5.1</b>	<b>Language select</b>	Y	100	1000	0	802	<b>129</b> = English
<b>P 5.2</b>	<b>Application select</b>	N	0	0	0	801	<b>0</b> = Application0
<b>P 5.5.1</b>	<b>Restore Defaults</b>	N	No	Yes	No	831	See Range
<b>P 5.5.2</b>	<b>Save to Keypad</b>	N	N/A	N/A	N/A	N/A	N/A
<b>P 5.5.3</b>	<b>From Keypad</b>	N	N/A	N/A	N/A	N/A	N/A
<b>P 5.7</b>	<b>Drive Name</b>	N	N/A	N/A	Drive	N/A	Any

## Parameter Descriptions

### P2.1...

Parameter Number	Parameter Name	Description
<b>P2.1.1</b>	<b>Application</b>	Determines Necessary Viewable and Hidden Parameters in accordance with Application Requirements
<b>P2.1.2</b>	<b>ByPass</b>	Used for 2 or 3 Contactor Bypass Applications. EMEA Products will have this default set to 0
<b>P2.1.3</b>	<b>HOA Control Stc</b>	Defines the HOA Control Location
<b>P2.1.4</b>	<b>Start Srce Hand</b>	Determines where the Hand Start Signal Source is controlled from. If I/O 3-wire is chosen the user must also program a "3-wire off" to input DI2–DI6
<b>P2.1.5</b>	<b>Speed Setpt Hand</b>	Defines the frequency reference input source when operating in the Hand mode
<b>P2.1.6</b>	<b>Start Srce Auto</b>	Determines where the Auto Start Signal Source is controlled from. If I/O 3-wire is chosen the user must also program a "3-wire off" to input DI2–DI6
<b>P2.1.7</b>	<b>Speed Setpt Auto</b>	Defines the frequency reference input source when operating in the Auto mode
<b>P2.1.8</b>	<b>Min Frequency</b>	Minimum Output Frequency (Hz)
<b>P2.1.9</b>	<b>Max Frequency</b>	Maximum Output Frequency (Hz). US product defaulted to 60 Hz. EMEA product defaulted to 50 Hz
<b>P2.1.10</b>	<b>Accel Time 1</b>	Time from Minimum Frequency to Maximum Frequency
<b>P2.1.11</b>	<b>Decel Time 1</b>	Time from Maximum Frequency to Minimum Frequency
<b>P2.1.12</b>	<b>Motor Nom Currnt</b>	Motor Nameplate Current (Amps)
<b>P2.1.13</b>	<b>Motor Nom Voltg</b>	Motor Nameplate Voltage (Volts)
<b>P2.1.14</b>	<b>Motor Nom Freq</b>	Motor Nameplate Frequency in Hertz
<b>P2.1.15</b>	<b>Motor Nom Speed</b>	Motor Nameplate Speed in RPMs
<b>P2.1.16</b>	<b>MotorPowerFactor</b>	Motor Nameplate Power Factor (Cos Phi)
<b>P2.1.17</b>	<b>Current Limit</b>	Output current limit of the unit in Amperes. When current limit is active, the output frequency will be decreased
<b>P2.1.18</b>	<b>Service Factor</b>	Motor service factor (SF). This will calculate the motor current limit. (MotorNomCurrent x Service Factor)

### P2.2...

Parameter Number	Parameter Name	Description
<b>P2.2.1.1</b>	<b>A11 Signal selection</b>	Analog Input 1 signal (connect to terminals 2 and 3 on the basic I/O board)
<b>P2.2.1.2</b>	<b>A11 Signal Inv</b>	Invert Input Signal
<b>P2.2.1.3</b>	<b>A11 Signal Range</b>	Analog Signal Ranges (Dip Switches on side of drive changes signal from voltage to current)
<b>P2.2.1.4</b>	<b>A11 Custom Min</b>	Custom Range Min Setting 20% = 4–20mA/2–10 Vdc (Example: if you will use a signal from 8 to 16 mA, you set ID380 to 40% and ID381 to 80%)
<b>P2.2.1.5</b>	<b>A11 Custom Max</b>	Custom Range Max Setting
<b>P2.2.1.6</b>	<b>A11 Filter Time</b>	Filter Time for Analog Input (When this parameter is given a value greater than 0 the function that filters out disturbances from the incoming analog signal is activated. A long filtering time makes the regulation response slower)
<b>P2.2.2.1</b>	<b>A12 Signal selection</b>	Analog Input 2 signal (connect to terminals 4 and 5 on the basic I/O board)
<b>P2.2.2.2</b>	<b>A12 Signal Inv</b>	Invert Input Signal
<b>P2.2.2.3</b>	<b>A12 Signal Range</b>	Analog Signal Ranges (Dip Switches on side of drive changes signal from voltage to current)
<b>P2.2.2.4</b>	<b>A12 Custom Min</b>	Custom Range Min Setting 20% = 4–20mA/2–10 Vdc (Example: if you will use a signal from 8 to 16 mA, you set ID380 to 40% and ID381 to 80%)
<b>P2.2.2.5</b>	<b>A12 Custom Max</b>	Custom Range Max Setting
<b>P2.2.2.6</b>	<b>A12 Filter Time</b>	Filter Time for Analog Input (When this parameter is given a value greater than 0 the function that filters out disturbances from the incoming analog signal is activated. A long filtering time makes the regulation response slower)

## P2.2..., continued

Parameter Number	Parameter Name	Description
P2.2.3.1	<b>AI3 Signal selection</b>	Analog Input 3 signal programmed by TTF (Terminal to Function)
P2.2.3.2	<b>AI3 Signal Inv</b>	Invert Input Signal
P2.2.3.3	<b>AI3 Signal Range</b>	Analog Signal Ranges
P2.2.3.4	<b>AI3 Custom Min</b>	Custom Range Min Setting 20% = 4–20mA/2–10 Vdc (Example: if you will use a signal from 8 to 16 mA, you set ID380 to 40% and ID381 to 80%)
P2.2.3.5	<b>AI3 Custom Max</b>	Custom Range Max Setting
P2.2.3.6	<b>AI3 Filter Time</b>	Filter Time for Analog Input (When this parameter is given a value greater than 0 the function that filters out disturbances from the incoming analog signal is activated. A long filtering time makes the regulation response slower)
P2.2.4.1	<b>AI4 Signal selection</b>	Analog Input 4 signal programmed by TTF (Terminal to Function)
P2.2.4.2	<b>AI4 Signal Inv</b>	Invert Input Signal
P2.2.4.3	<b>AI4 Signal Range</b>	Analog Signal Ranges
P2.2.4.4	<b>AI4 Custom Min</b>	Custom Range Min Setting 20% = 4–20mA/2–10 Vdc (Example: if you will use a signal from 8 to 16 mA, you set ID380 to 40% and ID381 to 80%)
P2.2.4.5	<b>AI4 Custom Max</b>	Custom Range Max Setting
P2.2.4.6	<b>AI4 Filter Time</b>	Filter Time for Analog Input (When this parameter is given a value greater than 0 the function that filters out disturbances from the incoming analog signal is activated. A long filtering time makes the regulation response slower)
P2.2.5.1	<b>AI5 Signal selection</b>	Analog Input 5 signal programmed by TTF (Terminal to Function)
P2.2.5.2	<b>AI5 Signal Inv</b>	Invert Input Signal
P2.2.5.3	<b>AI5 Signal Range</b>	Analog Signal Ranges
P2.2.5.4	<b>AI5 Custom Min</b>	Custom Range Min Setting 20% = 4–20mA/2–10 Vdc (Example: if you will use a signal from 8 to 16 mA, you set ID380 to 40% and ID381 to 80%)
P2.2.5.5	<b>AI5 Custom Max</b>	Custom Range Max Setting
P2.2.5.6	<b>AI5 Filter Time</b>	Filter Time for Analog Input (When this parameter is given a value greater than 0 the function that filters out disturbances from the incoming analog signal is activated. A long filtering time makes the regulation response slower)
P2.2.6.1	<b>AI6 Signal selection</b>	Analog Input 6 signal programmed by TTF (Terminal to Function)
P2.2.6.2	<b>AI6 Signal Inv</b>	Invert Input Signal
P2.2.6.3	<b>AI6 Signal Range</b>	Analog Signal Ranges
P2.2.6.4	<b>AI6 Custom Min</b>	Custom Range Min Setting 20% = 4–20mA/2–10 Vdc (Example: if you will use a signal from 8 to 16 mA, you set ID380 to 40% and ID381 to 80%)
P2.2.6.5	<b>AI6 Custom Max</b>	Custom Range Max Setting
P2.2.6.6	<b>AI6 Filter Time</b>	Filter Time for Analog Input (When this parameter is given a value greater than 0 the function that filters out disturbances from the incoming analog signal is activated. A long filtering time makes the regulation response slower)
P2.2.7.1	<b>Ref Scale Min.</b>	This parameter allows the scaling of the minimum frequency reference from its preset value to a value less than that set by the Reference Scale Maximum (ID 1308) parameter. If no scaling is desired, set this parameter to 0
P2.2.7.2	<b>Ref Scale Max.</b>	This parameter allows the scaling of the maximum frequency reference from its preset value to a value greater than that set by the Reference Scale Minimum (ID1307) parameter

## Parameter Descriptions

### P2.3...

Parameter Number	Parameter Name	Description
P2.3.1.1	D11 Open Invert	Digital Input 1 is locked in at Normally Open and is not editable
P2.3.1.2	D11 Function	Start input signal (non-configurable)
P2.3.2.1	DIN 2 Invert	This input allows the Digital Input to be either a Normally Open or a Normally Closed contact to cause the programmed function of this DIN
P2.3.2.2	DIN2 Function	Function of DIN2 within Drive
P2.3.3.1	DIN 3 Invert	This input allows the Digital Input to be either a Normally Open or a Normally Closed contact to cause the programmed function of this DIN
P2.3.3.2	DIN3 Function	Function of DIN3 within Drive
P2.3.4.1	DIN 4 Invert	This input allows the Digital Input to be either a Normally Open or a Normally Closed contact to cause the programmed function of this DIN
P2.3.4.2	DIN4 Function	Function of DIN4 within Drive
P2.3.5.1	DIN 5 Invert	This input allows the Digital Input to be either a Normally Open or a Normally Closed contact to cause the programmed function of this DIN
P2.3.5.2	DIN5 Function	Function of DIN5 within Drive
P2.3.6.1	DIN 6 Invert	This input allows the Digital Input to be either a Normally Open or a Normally Closed contact to cause the programmed function of this DIN
P2.3.6.2	DIN6 Function	Function of DIN6 within Drive. Default value is 33 if bypass is enabled
P2.3.7.1	Ext-D1 Terminal	This parameter allows programming an external Digital Input using the "Terminal-to-Function" method
P2.3.7.2	Ext-D1 Function	Function of Ext-D1 within Drive
P2.3.8.1	Ext-D2 Terminal	This parameter allows programming an external Digital Input using the "Terminal-to-Function" method
P2.3.8.2	Ext-D2 Function	Function of Ext-D2 within Drive
P2.3.9.1	Start logic	Start Functionality Normal—Interlocks are not used. Interlock start—When a start command is given, output signal "Damper Control Relay" is activated. The signal can be programmed to relay output and it can be connected to control an element of the driven system, such as damper. The drive is started when a feedback is provided to the Interlock input of the drive. Interlock time start—Functionality is similar to Interlock start. If the feedback signal is not active within the defined time, a message "Interlock Time Expired. Restart the drive" is given. Delay Start—Feedback signals are not used. The drive is started after a pre-defined delay.
P2.3.9.2	INTLK Timeout	Interlock timeout time for Start Function #2
P2.3.9.3	Delay Time	Start Delay time for Start Function #3
P2.3.9.4	Intrlk Stop Mode	Stop Mode if the Interlock Start is Triggered
P2.3.9.5	Interlock 1 Text	Text Associated with Interlock 1
P2.3.9.6	Interlock 2 Text	Text Associated with Interlock 2
P2.3.9.7	Interlock 3 Text	Text Associated with Interlock 3

### P2.4...

Parameter Number	Parameter Name	Description
P2.4.1.1	A01 Function	Analog Output Functionality
P2.4.1.2	A01 Filter Time	Analog Output A01 Filter
P2.4.1.3	A01 Min Signal	Analog Output A01 Minimum Signal Value
P2.4.1.4	A01 MinScale	Min Scale in Process Unit
P2.4.1.5	A01 MaxScale	Max Scale in Process Unit
P2.4.1.6	A01 Invert	Analog Output Signal Invert

## P2.5...

Parameter Number	Parameter Name	Description
P2.5.1.1	<b>R01 function</b>	Default value is 35 if bypass is enabled!
P2.5.1.2	<b>R01 Invert</b>	R01 Invert Function
P2.5.1.3	<b>R01 ON delay</b>	Delay On time before relay turns on
P2.5.1.4	<b>R01 OFF delay</b>	Delay Off time before relay turns on
P2.5.2.1	<b>R02 function</b>	R02 Function Setting
P2.5.2.2	<b>R02 Invert</b>	R02 Invert Function
P2.5.2.3	<b>R02 ON delay</b>	Delay On time before relay turns on
P2.5.2.4	<b>R02 OFF delay</b>	Delay Off time before relay turns off
P2.5.3.1	<b>R03 function</b>	R03 Function Setting
P2.5.9.1	<b>Superv1 Item</b>	Allows Drive to Trigger based on High or Low Limit
P2.5.9.2	<b>Supervision #1 mode</b>	Select a Low or High Limit if used
P2.5.9.3	<b>Supervision #1 limit</b>	Supervisory Limit Value
P2.5.9.4	<b>Supervision #1 limit hysteresis</b>	Supervisory Limit Reset Buffer
P2.5.9.4	<b>Supervision #2 limit hysteresis</b>	Supervisory Limit Reset Buffer
P2.5.9.5	<b>Superv2 Item</b>	Allows Drive to Trigger based on High or Low Limit
P2.5.9.6	<b>Supervision #2 mode</b>	Select a Low or High Limit if used
P2.5.9.7	<b>Supervision #2 limit</b>	Supervisory Limit Value

## P2.6...

Parameter Number	Parameter Name	Description
P2.6.1.1	<b>Start Function</b>	Start function from zero speed or when load is spinning
P2.6.1.2	<b>Stop Function</b>	How the drive stops the load after stop is given
P2.6.1.3	<b>InhibitDirection</b>	Function Prevents spinning in defined direction
P2.6.1.4	<b>Reference Unit</b>	Reference Unit that is displayed on the keypad
P2.6.1.5	<b>Keypad Reference</b>	Keypad Reference
P2.6.1.6	<b>Keypad Direction</b>	Direction of motor when in keypad control operation
P2.6.1.7	<b>Keypad Reference copy</b>	Selects function for Run State and Reference copy when changing to Keypad Control
P2.6.1.8	<b>Keypad Stop Button</b>	Keypad STOP button active or not, regardless of control place
P2.6.1.9	<b>Accel Time 2</b>	A second parameter for Acceleration can be set and can be chosen by inputs
P2.6.1.10	<b>Decel Time 2</b>	A second parameter for Deceleration can be set and can be chosen by inputs
P2.6.1.11	<b>RampselectMode</b>	Use this parameter to select acceleration ramp and deceleration ramp 2 by frequency limit or digital input
P2.6.1.12	<b>Accel2Threshold</b>	Acceleration ramp 2 is activated when output frequency goes over this limit. 0.0 = Not Used. It can also be turned on with a digital input
P2.6.1.13	<b>Decel2Threshold</b>	Deceleration ramp 2 is activated when output frequency goes below this limit. 0.0 = Not Used. It can also be turned on with a digital input
P2.6.1.14	<b>S-Ramp 1 Shape</b>	S-curve time ramp 1 used for smooth acceleration
P2.6.1.15	<b>S-Ramp 2 Shape</b>	S-curve time ramp 2 used for smooth acceleration

## Parameter Descriptions

### P2.6..., continued

Parameter Number	Parameter Name	Description
P2.6.2.1	Range 1 Low Lim	Skip frequency low limit area 1
P2.6.2.2	Range 1 High Lim	Skip frequency high limit area 1
P2.6.2.3	Range 2 Low Lim	Skip frequency low limit area 2
P2.6.2.4	Range 2 High Lim	Skip frequency high limit area 2
P2.6.2.5	Range 3 Low Lim	Skip frequency low limit area 3
P2.6.2.6	Range 3 High Lim	Skip frequency high limit area 3
P2.6.2.7	Range 4 Low Lim	Skip frequency low limit area 4
P2.6.2.8	Range 4 High Lim	Skip frequency high limit area 4
P2.6.2.9	Range 5 Low Lim	Skip frequency low limit area 5
P2.6.2.10	Range 5 High Lim	Skip frequency high limit area 5
P2.6.2.11	Range 6 Low Lim	Skip frequency low limit area 6
P2.6.2.12	Range 6 High Lim	Skip frequency high limit area 6
P2.6.2.13	RampTimeFactor	Defines the acceleration/deceleration time when the output frequency is between the selected skip frequency range limits. The accel/decel times (1 or 2) is multiplied by this factor

### P2.7...

Parameter Number	Parameter Name	Description
P2.7.1	V/Hz RatioSelect	V/Hz Ratio Selection
P2.7.2	Field WeakngPnt	Programmable Field Weakening (The field weakening point is the output frequency at which the output voltage reaches the nameplate rated voltage of the motor)
P2.7.3	Voltage at FWP	Above the frequency at the field weakening point, the output voltage remains at the set maximum value. Below the frequency at the field weakening point, the output voltage depends on the setting of the V/Hz curve parameters
P2.7.4	V/Hz Mid Freq	If the programmable U/f curve has been selected with parameter U/f Ratio, this parameter defines the middle point frequency of the curve
P2.7.5	V/Hz Mid Voltage	If the programmable U/f curve has been selected with parameter U/f Ratio, this parameter defines the middle point voltage of the curve
P2.7.6	Zero Freq Voltg	This parameter defines the zero frequency voltage of the U/f curve. The default value varies according to unit size
P2.7.7	Switching Freq	Motor noise can be minimized using a high switching frequency. Increasing switching frequency reduces the capacity of the frequency converter

### P2.8...

Parameter Number	Parameter Name	Description
P2.8.1.1	AI Low Fault	Response when an analog signal in use goes below 50% of the minimum signal range. If alarm + preset frequency is used, the frequency can be set in the references menu
P2.8.1.2	Undervoltage Flt	Enable or Disable Undervoltage Fault
P2.8.1.3	OutputPhase Flt	Output phase supervision of the motor ensures that the motor phases have an approximately equal current
P2.8.1.4	Motor Duty Cycle	Defines how much of the nominal motor load is applied
P2.8.1.5	Underload Flt	The purpose of motor underload protection is to ensure that there is load on the motor while the drive is running
P2.8.1.6	Motor Therm Prot	Motor thermal protection is based on a calculated model and uses the output current and output frequency to determine the load on the motor
P2.8.1.7	MotAmbient Temp	This parameter relates to the ambient temperature the motor is in

## P2.8..., continued

Parameter Number	Parameter Name	Description
P2.8.1.8	<b>ZeroSpeedCooling</b>	Defines the cooling factor at zero speed in relation to the point where the motor is running at nominal speed without external cooling
P2.8.1.9	<b>ThermTimeConst</b>	The time constant is the time within which the calculated thermal stage has reached 63% of its final value. The larger the motor, the longer the time constant
P2.8.1.10	<b>Thermistor Fault</b>	Response when the thermistor circuit opens in an available thermistor input. Thermistor inputs might be an option depending on frequency converter
P2.8.1.11	<b>External Fault</b>	Response when an external fault is activated
P2.8.1.12	<b>FieldbusComm Flt</b>	Response when fieldbus communication timeout occurs
P2.8.1.13	<b>InputPhaseFault</b>	The input phase supervision ensures that the input phases of the frequency converter have an approximately equal current
P2.8.1.14	<b>MotorStall Flt</b>	Stall protection is a type of overcurrent protection. It protects the motor from short time overload situations like a stalled shaft
P2.8.1.15	<b>PID1 Supervision</b>	Upper and lower limits around the reference are set. When the actual value goes above or below these a counter starts counting up towards the Delay. When the actual value is within the allowed area the same counter counts down instead. When ever the counter reaches its limit, the response selected will enable
P2.8.1.16	<b>PID2 Supervision</b>	Same as PID1 Supervision
P2.8.1.17	<b>SlotCommFlt</b>	Response for a Slot Fault
P2.8.1.18	<b>Preset Alarm Freq</b>	This frequency is used as reference when AI Low Fault response is Alarm and Preset Frequency
P2.8.2.1	<b>Automatic Reset</b>	Parameter to select mode for the automatic restart function
P2.8.2.2	<b>Restart function</b>	We can choose what kind of start function we want to use when doing an autoreset of the drive if run command is kept active during the autoreset sequence
P2.8.2.3	<b>Wait Time</b>	Defines the time before the frequency converter tries to automatically reset a fault
P2.8.2.4	<b>Trial Time</b>	The automatic reset function keeps trying to reset the faults appearing during the time set with this parameter. If the number of reset tries is exceeded within this time, or the fault remains, a non-automatically resettable fault is generated
P2.8.2.5	<b>Number of trials</b>	How many times we should try to reset the drive
P2.8.2.6	<b>Undervoltage Flt</b>	Defines if we should include fault in the automatic reset functions
P2.8.2.7	<b>Overvoltage Flt</b>	Defines if we should include fault in the automatic reset functions
P2.8.2.8	<b>Overcurrent Flt</b>	Defines if we should include fault in the automatic reset functions
P2.8.2.9	<b>AI Low Fault</b>	Defines if we should include fault in the automatic reset functions
P2.8.2.10	<b>UnitOverTemp Flt</b>	Defines if we should include fault in the automatic reset functions
P2.8.2.11	<b>MotorOverTempFlt (Yes or No)</b>	Defines if we should include fault in the automatic reset functions
P2.8.2.12	<b>External Fault (Yes or No)</b>	Defines if we should include fault in the automatic reset functions
P2.8.2.13	<b>IGBT temp</b>	Defines if we should include fault in the automatic reset functions

## Parameter Descriptions

### P2.9...

Parameter Number	Parameter Name	Description
P2.9.1.1.1	Gain, PID Controller 1	Defines the gain of the PID Controller
P2.9.1.1.2	Integration Time, PID Controller 1	Defines the integration time of the PID Controller
P2.9.1.1.3	Derivation Time, PID Controller 1	Defines the derivation time of the PID Controller
P2.9.1.1.4	ProcessUnitSel, PID Controller 1	Defines the unit type for PID Feedback
P2.9.1.1.5	ProcessUnitMin, PID Controller 1	Minimum Unit Value
P2.9.1.1.6	ProcessUnitMax, PID Controller 1	Maximum Unit Value
P2.9.1.1.7	ProcessUnitDecimals, PID Controller 1	Decimal places in Unit Value
P2.9.1.1.8	Error Inversion, PID Controller 1	Normal = If feedback is less than setpoint, PID controller output increases. Inverted = If feedback is less than setpoint, PID controller output decreases
P2.9.1.1.9	Dead Band, PID Controller 1	PID Deadband around setpoint
P2.9.1.1.10	Dead band delay, PID Controller 1	Delay in Locking the Deadband Output
P2.9.1.2.1	Keypad SP 1, PID Controller 1	Keypad setpoint 1
P2.9.1.2.2	Keypad SP 2, PID Controller 1	Keypad setpoint 2
P2.9.1.2.3	Ramp Time, PID Controller 1	Defines the rising and falling ramp times for setpoint changes
P2.9.1.2.4	SetPt 1 Source, PID Controller 1	Defines source of the setpoint
P2.9.1.2.5	SetPt 1 min, PID Controller 1	Defines Minimum Value at AI Minimum level
P2.9.1.2.6	SP 1 maximum, PID Controller 1	Defines Maximum Value at AI Maximum level
P2.9.1.2.7	SP 1 Sleep Freq, PID Controller 1	Drive goes to sleep mode when the output frequency stays below this limit for a time greater than that defined by parameter Sleep delay
P2.9.1.2.8	SP 1 Sleep delay, PID Controller 1	The minimum amount of time the frequency has to remain below the sleep level before the drive is stopped
P2.9.1.2.9	SP 1 WakeUpLevel, PID Controller 1	Defines the level for the PID feedback value wake-up supervision. Uses selected process units
P2.9.1.2.10	SP 1 boost, PID Controller 1	The setpoint can be boosted with a digital input
P2.9.1.2.11	SP 2 Source, PID Controller 1	Defines source of the setpoint
P2.9.1.2.12	SP 2 minimum, PID Controller 1	Defines Minimum Value at AI Minimum level
P2.9.1.2.13	SP 2 maximum, PID Controller 1	Defines Maximum Value at AI Maximum level
P2.9.1.2.14	SP 2 Sleep Freq, PID Controller 1	Drive goes to sleep mode when the output frequency stays below this limit for a time greater than that defined by parameter Sleep delay



**P2.9..., continued**

<b>Parameter Number</b>	<b>Parameter Name</b>	<b>Description</b>
<b>P2.9.1.2.15</b>	<b>SP 2 Sleep delay, PID Controller 1</b>	The minimum amount of time the frequency has to remain below the sleep level before the drive is stopped
<b>P2.9.1.2.16</b>	<b>SP 2 WakeUpLevel, PID Controller 1</b>	Defines the level for the PID feedback value wake-up supervision. Uses selected process units
<b>P2.9.1.2.17</b>	<b>SP 2 boost, PID Controller 1</b>	The setpoint can be boosted with a digital input
<b>P2.9.1.3.1</b>	<b>Function, PID Controller 1</b>	Choose a single signal used as feedback
<b>P2.9.1.3.2</b>	<b>Gain, PID Controller 1</b>	Define Gain associated with feedback
<b>P2.9.1.3.3</b>	<b>FeedBack 1 Srce, PID Controller 1</b>	Define where feedback signal is from
<b>P2.9.1.3.4</b>	<b>FB 1 Minimum, PID Controller 1</b>	Minimum Unit Value
<b>P2.9.1.3.5</b>	<b>FB 1 Maximum, PID Controller 1</b>	Maximum Unit Value
<b>P2.9.1.3.6</b>	<b>FB 2 Source, PID Controller 1</b>	Define where feedback signal is from
<b>P2.9.1.3.7</b>	<b>FB 2 Minimum, PID Controller 1</b>	Minimum Unit Value
<b>P2.9.1.3.8</b>	<b>FB 2 Maximum, PID Controller 1</b>	Maximum Unit Value
<b>P2.9.1.4.1</b>	<b>Function, PID Controller 1</b>	Choose a single signal used as feedforward
<b>P2.9.1.4.2</b>	<b>Gain, PID Controller 1</b>	Define feedforward gain
<b>P2.9.1.4.3</b>	<b>FF 1 Source, PID Controller 1</b>	Define where feedforward signal is from
<b>P2.9.1.4.4</b>	<b>FF1 Minimum, PID Controller 1</b>	Minimum Unit Value
<b>P2.9.1.4.5</b>	<b>FF1 Maximum, PID Controller 1</b>	Maximum Unit Value
<b>P2.9.1.4.6</b>	<b>FF 2 Source, PID Controller 1</b>	Define where feedforward signal is from
<b>P2.9.1.4.7</b>	<b>FF2 Minimum, PID Controller 1</b>	Minimum Unit Value
<b>P2.9.1.4.8</b>	<b>FF2 Maximum, PID Controller 1</b>	Maximum Unit Value
<b>P2.9.1.5.1</b>	<b>Enable Superv, PID Controller 1</b>	Controls the actual value within predefined limits. Can detect a major pipe burst or unnecessary flooding
<b>P2.9.1.5.2</b>	<b>Upper limit, PID Controller 1</b>	Upper actual/process value supervision
<b>P2.9.1.5.3</b>	<b>Lower limit, PID Controller 1</b>	Lower actual/process value supervision
<b>P2.9.1.5.4</b>	<b>Delay, PID Controller 1</b>	If the desired value is not reached within this time a fault or alarm is created
<b>P2.9.1.6.1</b>	<b>Enable SP 1, PID Controller 1</b>	Enables pressure loss compensation for setpoint 1
<b>P2.9.1.6.2</b>	<b>SP 1 Max Comp., PID Controller 1</b>	Value added proportionally to the frequency
<b>P2.9.1.6.3</b>	<b>Enable SP 2, PID Controller 1</b>	Enables pressure loss compensation for setpoint 2

## Parameter Descriptions

### P2.9..., continued

Parameter Number	Parameter Name	Description
P2.9.1.6.4	SP 2 Max Comp., PID Controller 1	Value added proportionally to the frequency
P2.9.2.1.1	Gain, PID Controller 2	Defines the gain of the PID Controller
P2.9.2.1.2	Integration Time, PID Controller 2	Defines the integration time of the PID Controller
P2.9.2.1.3	Derivation Time, PID Controller 2	Defines the derivation time of the PID Controller
P2.9.2.1.4	ProcessUnitSel, PID Controller 2	Defines the unit type for PID Feedback
P2.9.2.1.5	ProcessUnitMin, PID Controller 2	Minimum Unit Value
P2.9.2.1.6	ProcessUnitMax, PID Controller 2	Maximum Unit Value
P2.9.2.1.7	ProcessUnitDecimals, PID Controller 2	Decimal places in Unit Value
P2.9.2.1.8	Error Inversion, PID Controller 2	Normal = If feedback is less than setpoint, PID controller output increases. Inverted = If feedback is less than setpoint, PID controller output decreases
P2.9.2.1.9	Dead Band, PID Controller 2	PID Deadband around setpoint
P2.9.2.1.10	Dead band delay, PID Controller 2	Delay in Locking the Deadband Output
P2.9.2.2.1	Keypad SP 1, PID Controller 2	Keypad setpoint 1
P2.9.2.2.2	Keypad SP 2, PID Controller 2	Keypad setpoint 2
P2.9.2.2.3	Ramp Time, PID Controller 2	Defines the rising and falling ramp times for setpoint changes
P2.9.2.2.4	SetPt 1 Source, PID Controller 2	Defines source of the setpoint
P2.9.2.2.5	SetPt 1 min, PID Controller 2	Defines Minimum Value at AI Minimum level
P2.9.2.2.6	SP 1 maximum, PID Controller 2	Defines Maximum Value at AI Maximum level
P2.9.2.2.7	SP 2 Source, PID Controller 2	Defines source of the setpoint
P2.9.2.2.8	SP 2 minimum, PID Controller 2	Defines Minimum Value at AI Minimum level
P2.9.2.2.9	SP 2 maximum, PID Controller 2	Defines Maximum Value at AI Maximum level
P2.9.2.3.1	Function, PID Controller 2	Choose a single signal used as feedback
P2.9.2.3.2	Gain, PID Controller 2	Define Gain associated with feedback
P2.9.2.3.3	FeedBack 1 Srce, PID Controller 2	Define where feedback signal is from
P2.9.2.3.4	FB 1 Minimum, PID Controller 2	Minimum Unit Value
P2.9.2.3.5	FB 1 Maximum, PID Controller 2	Maximum Unit Value

**P2.9... , continued**

<b>Parameter Number</b>	<b>Parameter Name</b>	<b>Description</b>
P2.9.2.3.6	<b>FB 2 Source, PID Controller 2</b>	Define where feedback signal is from
P2.9.2.3.7	<b>FB 2 Minimum, PID Controller 2</b>	Minimum Unit Value
P2.9.2.3.8	<b>FB 2 Maximum, PID Controller 2</b>	Maximum Unit Value
P2.9.2.4.1	<b>Enable Superv, PID Controller 2</b>	Controls the actual value within predefined limits. Can detect a major pipe burst or unnecessary flooding
P2.9.2.4.2	<b>Upper limit, PID Controller 2</b>	Upper actual/process value supervision
P2.9.2.4.3	<b>Lower limit, PID Controller 2</b>	Lower actual/process value supervision
P2.9.2.4.4	<b>Delay, PID Controller 2</b>	If the desired value is not reached within this time a fault or alarm is created

**P2.10...**

<b>Parameter Number</b>	<b>Parameter Name</b>	<b>Description</b>
P2.10.1	<b>Preset Freq 1</b>	Used according to state of digital inputs Preset Frequency Sel0, Sel1, Sel2
P2.10.2	<b>Preset Freq 2</b>	Same as Preset Freq 1
P2.10.3	<b>Preset Freq 3</b>	Same as Preset Freq 1
P2.10.4	<b>Preset Freq 4</b>	Same as Preset Freq 1
P2.10.5	<b>Preset Freq 5</b>	Same as Preset Freq 1
P2.10.6	<b>Preset Freq 6</b>	Same as Preset Freq 1
P2.10.7	<b>Preset Freq 7</b>	Same as Preset Freq 1

**P2.11...**

<b>Parameter Number</b>	<b>Parameter Name</b>	<b>Description</b>
P2.11.1	<b>Firemode Freq</b>	Frequency to be used in when fire mode is activated. This will be hidden if in Multi-Pump Mode

**P2.12...**

<b>Parameter Number</b>	<b>Parameter Name</b>	<b>Description</b>
P2.12.1	<b>Number of motors</b>	Total number of motors/pumps used with the Multi-Pump System
P2.12.2	<b>Interlock function</b>	Input tells the drive if a motor/pump is connected or not
P2.12.3	<b>Include FC</b>	Input tells the drive if the motor/pump is included in the autochange and interlock system
P2.12.4	<b>Autochange</b>	Autochange will rotate the starting order/priority of the motors in the system to get equal wear on all motors
P2.12.5	<b>Autochange interval</b>	Defines how often to rotate starting order of motors/pumps
P2.12.6	<b>Autochange: frequency limit</b>	An autochange is done when the autochange interval has elapsed and the drive is running below autochange frequency limit
P2.12.7	<b>Autochange: motor limit</b>	An autochange is done when the autochange interval has elapsed and the number of running motors is less than autochange motor limit
P2.12.8	<b>Bandwidth</b>	Percentage of the setpoint defining when motor disconnection or removal will not take place
P2.12.9	<b>Bandwidth delay</b>	With feedback outside the bandwidth, this time must pass before pumps are added or removed

## Parameter Descriptions

### P2.13...

Parameter Number	Parameter Name	Description
P2.13.1	DC Brake Current	DC Brake Current in Stop
P2.13.2	DC Time Stop	DC Braking Time at Stop
P2.13.3	DC BrakeFreqStop	The output frequency at which the DC-braking is applied
P2.13.4	StartMagnTime	DC brake time in start
P2.13.5	StartMagnCurrent	DC brake current in Start
P2.13.6	Preheat Current	DC current for Pre-heating of motor and drive in stop state. Activated by digital input or by temperature limit

### P2.14...

Parameter Number	Parameter Name	Description
P2.14.1	FB Data Out1 Sel	Data sent to fieldbus can be chosen with parameter and monitor value ID numbers. The data is scaled to unsigned 16bit format according to format on panel
P2.14.2	FB Data Out2 Sel	Same as FB Data Out1 Sel
P2.14.3	FB Data Out3 Sel	Same as FB Data Out1 Sel
P2.14.4	FB Data Out4 Sel	Same as FB Data Out1 Sel
P2.14.5	FB Data Out5 Sel	Same as FB Data Out1 Sel
P2.14.6	FB Data Out6 Sel	Same as FB Data Out1 Sel
P2.14.7	FB Data Out7 Sel	Same as FB Data Out1 Sel
P2.14.8	FB Data Out8 Sel	Same as FB Data Out1 Sel

### P2.15...

Parameter Number	Parameter Name	Description
P2.15.1.1	Motor Nom Currnt, Set2	Motor 2 Nameplate Data
P2.15.1.2	Motor Nom Voltg, Set2	Motor 2 Nameplate Data
P2.15.1.3	Motor Nom Freq, Set2	Motor 2 Nameplate Data
P2.15.1.4	Motor Nom Speed, Set2	Motor 2 Nameplate Data
P2.15.1.5	MotorPowerFactor, Set2	Motor 2 Nameplate Data
P2.15.1.6	Current Limit, Set2	Output current limit of the frequency converter
P2.15.1.7	Motor Therm Prot, Set2	Motor 2 thermal protection is based on a calculated model and uses the output current and output frequency to determine the load on the motor
P2.15.2.1	Min Frequency, Set2	Motor 2 Minimum Frequency
P2.15.2.2	Max Frequency, Set2	Motor 2 Maximum Frequency
P2.15.2.3	Accel Time 1, Set2	Time from Minimum Frequency to Maximum Frequency
P2.15.2.4	Decel Time 1, Set2	Time from Maximum Frequency to Minimum Frequency
P2.15.2.5	V/Hz RatioSelect, Set2	Type of U/f curve between zero frequency and field weakening point

## P2.16...

Parameter Number	Parameter Name	Description
P2.16.1.1	ON Time, Interval 1	Drive timer On time
P2.16.1.2	Off Time, Interval 1	Drive timer Off time
P2.16.1.3	From Day, Interval 1	On day of week
P2.16.1.4	To Day, Interval 1	Off day of week
P2.16.1.5	Assign to channel, Interval 1	Select affected time channel
P2.16.2.1	ON Time, Interval 2	Drive timer On time
P2.16.2.2	Off Time, Interval 2	Drive timer Off time
P2.16.2.3	From Day, Interval 2	On day of week
P2.16.2.4	To Day, Interval 2	Off day of week
P2.16.2.5	Assign to channel, Interval 2	Select affected time channel
P2.16.3.1	ON Time, Interval 3	Drive timer On time
P2.16.3.2	Off Time, Interval 3	Drive timer Off time
P2.16.3.3	From Day, Interval 3	On day of week
P2.16.3.4	To Day, Interval 3	Off day of week
P2.16.3.5	Assign to channel, Interval 3	Select affected time channel
P2.16.4.1	ON Time, Interval 4	Drive timer On time
P2.16.4.2	Off Time, Interval 4	Drive timer Off time
P2.16.4.3	From Day, Interval 4	On day of week
P2.16.4.4	To Day, Interval 4	Off day of week
P2.16.4.5	Assign to channel, Interval 4	Select affected time channel
P2.16.5.1	ON Time, Interval 5	Drive timer On time
P2.16.5.2	Off Time, Interval 5	Drive timer Off time
P2.16.5.3	From Day, Interval 5	On day of week
P2.16.5.4	To Day, Interval 5	Off day of week
P2.16.5.5	Assign to channel, Interval 5	Select affected time channel
P2.16.6.1	Duration	The time the timer will run when activated
P2.16.6.2	Assign to channel	Associate duration with a time channel
P2.16.7.1	Duration	The time the timer will run when activated
P2.16.7.2	Assign to channel	Associate duration with a time channel
P2.16.8.1	Duration	The time the timer will run when activated
P2.16.8.2	Assign to channel	Associate duration with a time channel

## Diagnostics

Under this menu, you can find *Active faults*, *Reset faults*, *Fault history*, *Counters* and *Software info*.

### Active Faults

Menu	Function	Note
Active faults	When a fault/faults appear(s), the display with the name of the fault starts to blink. Press OK to return to the Diagnostics menu. The <i>Active faults</i> submenu shows the number of faults. Select the fault and push OK to see the fault-time data.	The fault remains active until it is cleared with the Reset button (push for 2s) or with a reset signal from the I/O terminal or Fieldbus or by choosing <i>Reset faults</i> (see below). The memory of active faults can store the maximum of 10 faults in the order of appearance.

### Reset Faults

Menu	Function	Note
Reset faults	In this menu you can reset faults. For closer instructions.	 <b>CAUTION!</b> Remove external Control signal before resetting the fault to prevent unintentional restart of the drive.

### Fault History

Menu	Function	Note
Fault history	40 latest faults are stored in the Fault history.	Entering the Fault history and clicking OK on the selected fault shows the fault time data (details).

## Fault Codes

### Fault Codes and Descriptions

Fault Code	Fault ID	Fault Name	Possible Cause	Remedy
1	1	Overcurrent (hardware fault)	AC drive has detected too high a current ( $>4 \cdot I_H$ ) in the motor cable:	<ul style="list-style-type: none"> <li>• Check loading</li> <li>• Check motor</li> <li>• Check cables and connections</li> <li>• Make identification run</li> <li>• Check ramp times</li> </ul>
	2	Overcurrent (software fault)	<ul style="list-style-type: none"> <li>• Sudden heavy load increase</li> <li>• Short circuit in motor cables</li> <li>• Unsuitable motor</li> </ul>	
2	10	Overvoltage (hardware fault)	The DC-link voltage has exceeded the limits defined:	<ul style="list-style-type: none"> <li>• Make deceleration time longer</li> <li>• Use brake chopper or brake resistor (available as options)</li> <li>• Activate overvoltage controller</li> <li>• Check input voltage</li> </ul>
	11	Overvoltage (software fault)	<ul style="list-style-type: none"> <li>• Too short a deceleration time</li> <li>• Brake chopper is disabled</li> <li>• High overvoltage spikes in supply</li> <li>• Start/Stop sequence too fast</li> </ul>	
3	20	Earth fault (hardware fault)	Current measurement has detected that the sum of motor phase current is not zero:	Check motor cables and motor
	21	Earth fault (software fault)	<ul style="list-style-type: none"> <li>• Insulation failure in cables or motor</li> </ul>	
5	40	Charging switch	The charging switch is open, when the START command has been given: <ul style="list-style-type: none"> <li>• Faulty operation</li> <li>• Component failure</li> </ul>	<ul style="list-style-type: none"> <li>• Reset the fault and restart</li> <li>• Should the fault re-occur, contact the distributor near to you</li> </ul>

## Fault Codes and Descriptions, continued

Fault Code	Fault ID	Fault Name	Possible Cause	Remedy	
7	60	Saturation	Various causes: <ul style="list-style-type: none"> <li>Defective component</li> <li>Brake resistor short-circuit or overload</li> </ul>	<ul style="list-style-type: none"> <li>Cannot be reset from keypad</li> <li>Switch off power</li> <li>DO NOT RECONNECT POWER! Contact factory</li> <li>If this fault appears simultaneously with F1, check motor cables and motor</li> </ul>	
8	600	System fault	Communication between control board and power unit has failed	Reset the fault and restart. Should the fault re-occur, contact the distributor near you	
	602		Watchdog has reset the CPU		
	603		Voltage of auxiliary power in power unit is too low		
	604		Phase fault: Voltage of an output phase does not follow the reference		
	605		CPLD has faulted but there is no detailed information about the fault		
	606		Control and power unit software are incompatible		Update software. Should the fault re-occur, contact the distributor near you
	607		Software version cannot be read. There is no software in power unit		Update power unit software. Should the fault re-occur, contact the distributor near you
	608		CPU overload. Some part of the software (for example application) has caused an overload situation. The source of fault has been suspended		Reset the fault and restart. Should the fault re-occur, contact the distributor near you
	609		Memory access has failed. For example, retain variables could not be restored		
	610		Necessary device properties cannot be read		
	647		Software error		Update software. Should the fault re-occur, contact the distributor near you
	648		Invalid function block used in application. System software and application are not compatible		
	649		Resource overload: <ul style="list-style-type: none"> <li>Error when loading parameter initial values</li> <li>Error when restoring parameters</li> <li>Error when saving parameters</li> </ul>		
9	80	Undervoltage (fault)	DC link voltage is under the voltage limits defined:	In case of temporary supply voltage break reset the fault and restart the AC drive. Check the supply voltage. If it is adequate, an internal failure has occurred. Contact the distributor near you	
	81	Undervoltage (alarm)	<ul style="list-style-type: none"> <li>Most probable cause: Too low a supply voltage</li> <li>AC drive internal fault</li> <li>Defect input fuse</li> <li>External charge switch not closed</li> </ul> <p><b>Note:</b> This fault is activated only if the drive is in Run state.</p>		
10	91	Input phase	Input line phase is missing	Check supply voltage, fuses and cable	
11	100	Output phase supervision	Current measurement has detected that there is no current in one motor phase	Check motor cable and motor	

## Fault Codes and Descriptions, continued

Fault Code	Fault ID	Fault Name	Possible Cause	Remedy
12	110	Brake chopper supervision (hardware fault)	<ul style="list-style-type: none"> <li>No brake resistor installed</li> <li>Brake resistor is broken</li> <li>Brake chopper failure</li> </ul>	Check brake resistor and cabling. If these are OK, the chopper is faulty. Contact the distributor near you
	111	Brake chopper saturation alarm		
13	120	AC drive undertemperature (fault)	Too low temperature measured in power unit's heatsink or board. Heat-sink temperature is under $-10^{\circ}\text{C}$	—
	121	AC drive overtemperature (alarm)		
14	130	AC drive overtemperature (fault, heatsink)	Too high temperature measured in power unit's heatsink or board. Heat-sink temperature is over $100^{\circ}\text{C}$	<ul style="list-style-type: none"> <li>Check the correct amount and flow of cooling air</li> <li>Check the heatsink for dust</li> <li>Check the ambient temperature</li> <li>Make sure that the switching frequency is not too high in relation to ambient temperature and motor load</li> </ul>
	131	AC drive overtemperature (alarm, heatsink)		
	132	AC drive overtemperature (fault, board)		
	133	AC drive overtemperature (alarm, board)		
15	140	Motor stalled	Motor is stalled	Check motor and load
16	150	Motor overtemperature	Motor is overloaded	Decrease motor load. If no motor overload exists, check the temperature model parameters
17	160	Motor underload	Motor is underloaded	Check load
19	180	Power overload (short-time supervision)	Drive power is too high	Decrease load
	181	Power overload (long-time supervision)		
25	—	Motor control fault	Start angle identification has failed. Generic motor control fault	—
32	312	Fan cooling	Fan lifetime is up	Change fan and reset fan lifetime counter
33	—	Fire mode enabled	Fire mode of the drive is enabled. The drive's protections are not in use	—
37	360	Device changed (same type)	Option board changed for one previously inserted in the same slot. The board's parameter settings are saved	Device is ready for use. Old parameter settings will be used
38	370	Device changed (same type)	Option board added. The option board was previously inserted in the same slot. The board's parameter settings are saved	Device is ready for use. Old parameter settings will be used
39	380	Device removed	Optional board removed from slot	Device no longer available
40	390	Device unknown	Unknown device connected (power unit/option board)	Device no longer available
41	400	IGBT temperature	IGBT temperature (unit temperature + $I_2T$ ) is too high	<ul style="list-style-type: none"> <li>Check loading</li> <li>Check motor size</li> <li>Make identification run</li> </ul>
43	420	Encoder fault	Encoder 1 channel A is missing	<ul style="list-style-type: none"> <li>Check encoder connections</li> <li>Check encoder and encoder cable</li> <li>Check encoder board</li> <li>Check encoder frequency in open loop</li> </ul>
	421		Encoder 1 channel B is missing	
	422		Both encoder 1 channels are missing	
	423		Encoder reversed	
	424		Encoder board missing	



**Fault Codes and Descriptions, continued**

<b>Fault Code</b>	<b>Fault ID</b>	<b>Fault Name</b>	<b>Possible Cause</b>	<b>Remedy</b>
44	430	Device changed (different type)	Option board changed for one not present in the same slot before. No parameter settings are saved	Set the option board parameters again
45	440	Device changed (different type)	Option board added. The option board was not previously present in the same slot. No parameter settings are saved	Set the option board parameters again
51	1051	External fault	Digital input	—
52	1052 1352	Keypad communication fault	The connection between the control keypad and frequency converter is broken	Check keypad connection and possible keypad cable
53	1053	Fieldbus communication fault	The data connection between the Fieldbus master and Fieldbus board is broken	Check installation and Fieldbus master
54	1354 1454 1654 1754	Slot A fault Slot B fault Slot D fault Slot E fault	Defective option board or slot	Check board and slot
65	1065	PC communication fault	The data connection between the PC and frequency converter is broken	—
66	1066	Thermistor fault	The thermistor input has detected an increase of motor temperature	<ul style="list-style-type: none"> <li>• Check motor cooling and load</li> <li>• Check thermistor connection (if thermistor input is not in use it has to be short circuited)</li> </ul>
69	1310 1311 1312	Fieldbus mapping error	<p>Non-existing ID number is used for mapping values to Fieldbus Process Data Out</p> <p>Not possible to convert one or more values for Fieldbus Process Data Out</p> <p>Overflow when mapping and converting values for Fieldbus Process Data Out (16-bit)</p>	<p>Check parameters in Fieldbus Data Mapping menu</p> <p>The value being mapped may be of undefined type. Check parameters in Fieldbus Data Mapping menu</p> <p>—</p>
101	1101	Process supervision fault (PID1)	PID controller: Feedback value outside of supervision limits (and the delay if set)	—
105	1105	Process supervision fault (PID2)	PID controller: Feedback value outside of supervision limits (and the delay if set)	—

## Counters

**Total Counters** (Counters cannot be cleared)

Parameter Number	Parameter Name	Unit	ID	Description
<b>M 3.4.1</b>	<b>Energy counter</b>	kWh	2291	Amount of energy taken from net
<b>M 3.4.3</b>	<b>Operating time</b>	0a xxd xx:xx	0	Control unit's operating time
<b>M 3.4.7</b>	<b>Run Time</b>	0a xxd xx:xx	0	Motor running time
<b>M 3.4.11</b>	<b>Power On Time</b>	0a xxd xx:xx	0	Power unit's power on time
<b>M 3.4.15</b>	<b>Start Cmd Counter</b>	Number	2295	How many times power unit has been started

**Trip Counters** (Counters can be reset)

Parameter Number	Parameter Name	Change in Run	Min.	Max.	Default	ID	Description
<b>P 3.5.1</b>	<b>Energy counter</b>	Y	0.000	99999.999	Running	2296	Amount of energy taken from the network during operating time
<b>P 3.5.3</b>	<b>Operating time</b>	Y	0a 5d 00:00	0a 5d 00:00	Running	NA	Duration of the energy consumption associated with P3.5.1 This is resettable

## Software

**Software Information**

Parameter Number	Parameter Name	Unit	ID	Description
<b>M 3.6.1</b>	<b>Software package</b>	N/A	N/A	Software package
<b>M 3.6.4</b>	<b>System load</b>	N/A	2300	Control units CPU usage
<b>M 3.6.5</b>	<b>Application Name</b>	N/A	N/A	Application Name
<b>M 3.6.6</b>	<b>Application ID</b>	N/A	N/A	Application ID
<b>M 3.6.7</b>	<b>Application Ver.</b>	N/A	N/A	Application Ver.

# Communications

## BACnet Protocol

### BACnet General Information

BACnet stands for Building Automation and Control Networks. It is the common name for the communication standard ISO 16484-5 which defines the methods and the protocol for cooperating building automation devices to communicate. Devices can be designed to operate using BACnet communication protocol as well as utilizing BACnet protocol to communicate between systems. BACnet is an internationally accepted protocol for building automation (such as lighting control, air conditioning and heating automation) and control over a communications network.

BACnet provides a method by which computer-based control equipment, from different manufacturers can work together, or “interoperate”. For this to be achieved, components must be able to exchange and understand BACnet data messages.

Your H-Max HVAC drive is equipped with BACnet support as standard.

### Principal Example Diagram of BACnet

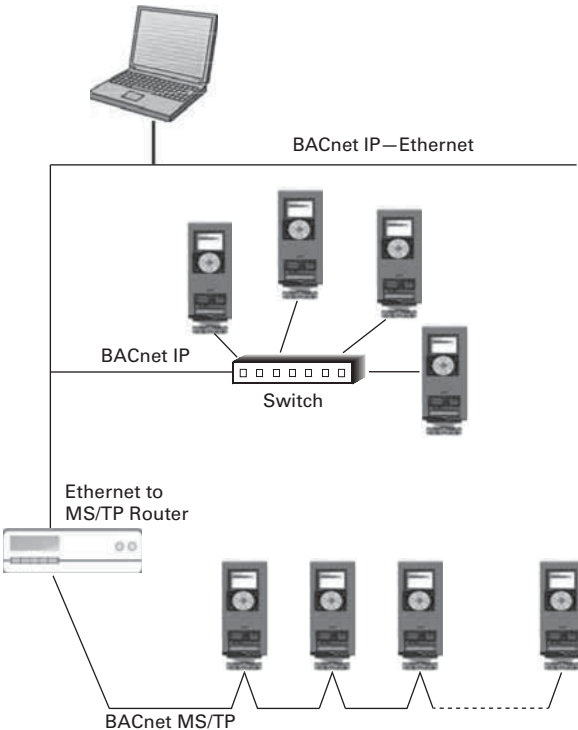

### BACnet Technical Data

#### BACnet MS/TP Protocol

Connection	Communication
Interface	RS-485
Data transfer method	RS-485 MS/TP, half-duplex
Transfer cable	STP (Shielded Twisted Pair), type Belden or similar
Connector	2.5 mm <sup>2</sup>
Electrical isolation	Functional
BACnet MS/TP	As described in ANSI/ASHRAE Standards 135-2004
Baud rate	9600, 19200, 38400 and 76800 baud (supports autobaud detection)

#### BACnet IP Protocol

Connection	Communication
Interface	100BaseTX, IEEE 802.3 compatible
Data transfer method	Ethernet half-/full-duplex
Data transfer speed	10/100 MBit/s, autosensing
Protocol	BACnet over UDP/IP
Connector	Shielded RJ45 connector
Cable type	CAT5e STP
BACnet IP	As described in ANSI/ASHRAE Standards 135-2004
Default IP	Selectable: Fixed or DHCP

### BACnet Installation

1. Open the cover of the AC drive.

**⚠ WARNING**

The relay outputs and other I/O-terminals may have a dangerous control voltage present even when H-Max is disconnected from mains.

2. Locate the components that you will need on the AC drive to connect and run the BACnet cables.

**⚠ WARNING**

Be sure not to plug the Ethernet/BACnet IP cable to the terminal under the keypad! This might harm your personal computer.

**AC Drive Components (BACnet)**

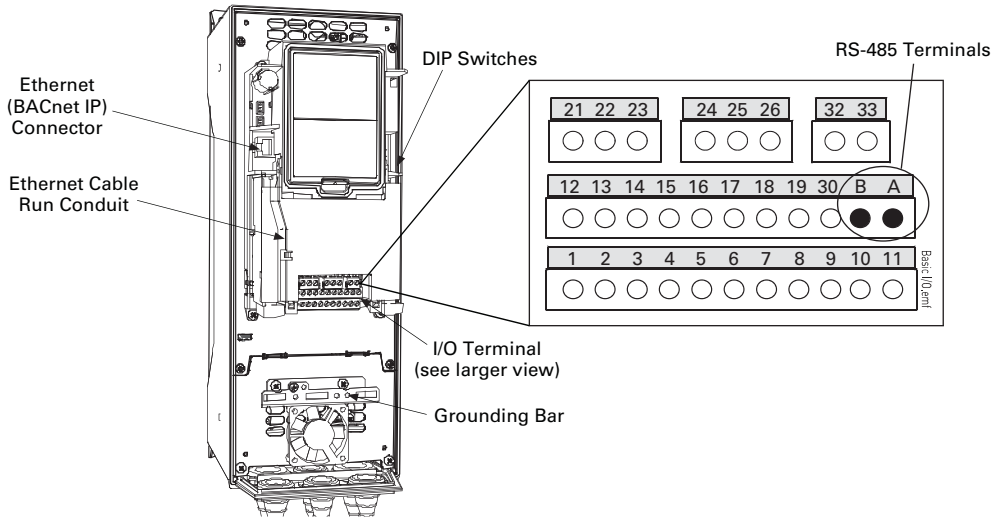

You can use the BACnet communication protocol through Ethernet and RS-485.

**Prepare For Use Through Ethernet**

1. Connect the Ethernet cable (see specification on **Page 77**) to its terminal and run the cable through the conduit as shown below.

**BACnet Ethernet Cable**

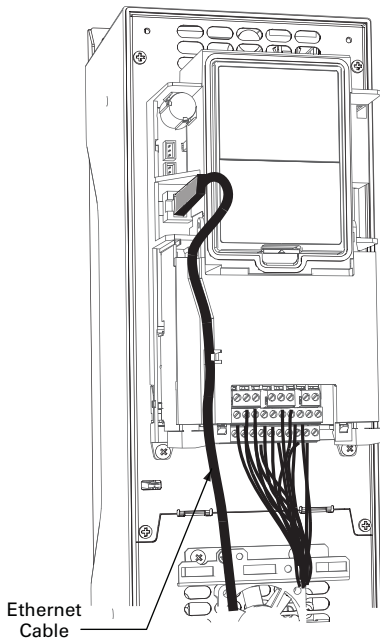

2. Remount the AC drive cover.

**Note:** When planning the cable runs, remember to keep the distance between the Ethernet cable and the motor cable at a **minimum of 11.81 in (30 cm)**.

**Prepare For Use Through MS/TP**

1. Strip about 0.59 in (15 mm) of the RS-485 cable (see specification on **Page 77**) and cut off the grey cable shield. Remember to do this for both bus cables (except for the last device).

Leave no more than 0.39 in (10 mm) of the cable outside the terminal block and strip the cables at about 0.20 in (5 mm) to fit in the terminals. See illustration below.

**RS-485 Cable Strip**

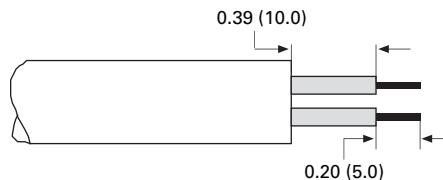

Also strip the cable now at such a distance from the terminal that you can fix it to the frame with the grounding clamp. Strip the cable at a maximum length of 0.59 in (15 mm).

**! IMPORTANT**

Do not strip the aluminum cable shield!

**RS-485 Cable Strip (Aluminum Shield)**

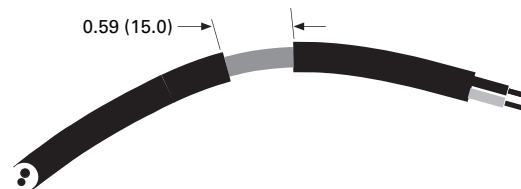

- 2. Then connect the cable to its appropriate terminals on H-Max AC drive standard terminal block, terminals **A and B** (A = negative, B = positive). See illustration below.

**H-Max AC Drive Terminals (BACnet)**

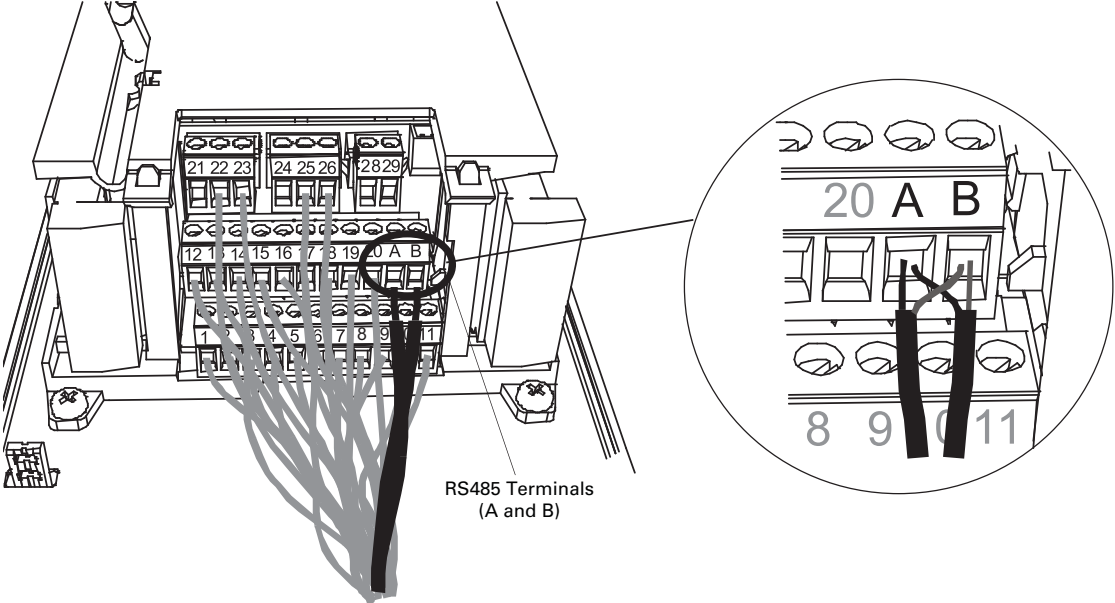

- 3. Using the cable clamp included in the delivery of the drive, ground the shield of the RS-485 cable to the frame of the AC drive.

**RS-485 Ground**

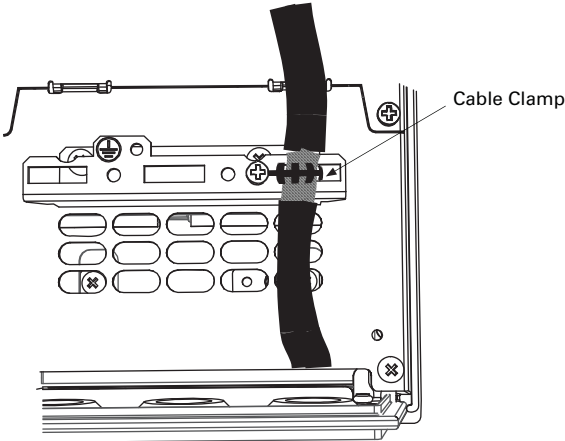

4. **If H-Max is the last device on the bus**, the bus termination must be set. Locate the DIP switches to the right of the control keypad of the drive and turn the switch for the RS-485 bus termination resistor to position ON. Biasing is built in the termination resistor. See also step 6 below.

**RS-485 Bus Termination Setup**

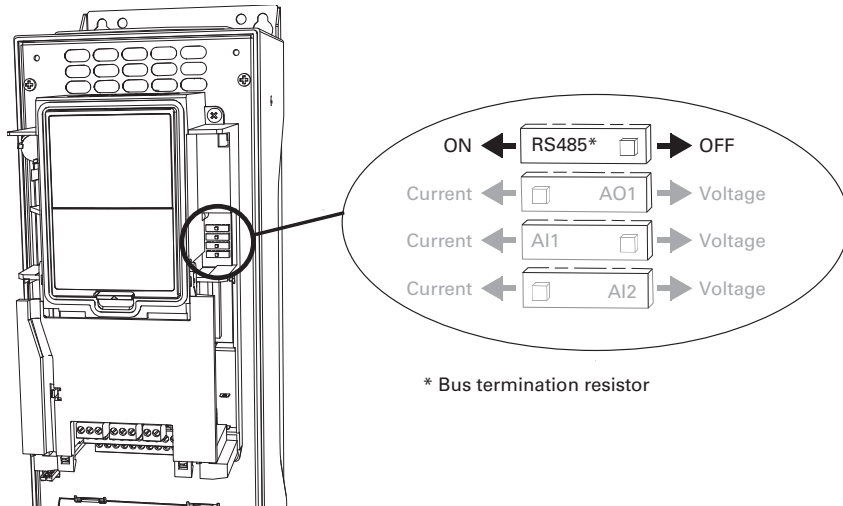

5. Remount the AC drive cover.

**Note:** When planning the cable runs, remember to keep the distance between the fieldbus cable and the motor cable at a **minimum of 11.81 in (30 cm)**.

6. The bus termination must be set for the first and last device of the fieldbus line. See illustration below. See also step 4 above. We recommend that the first device on the bus terminated is the Master device.

**BACnet MS/TP Bus Termination**

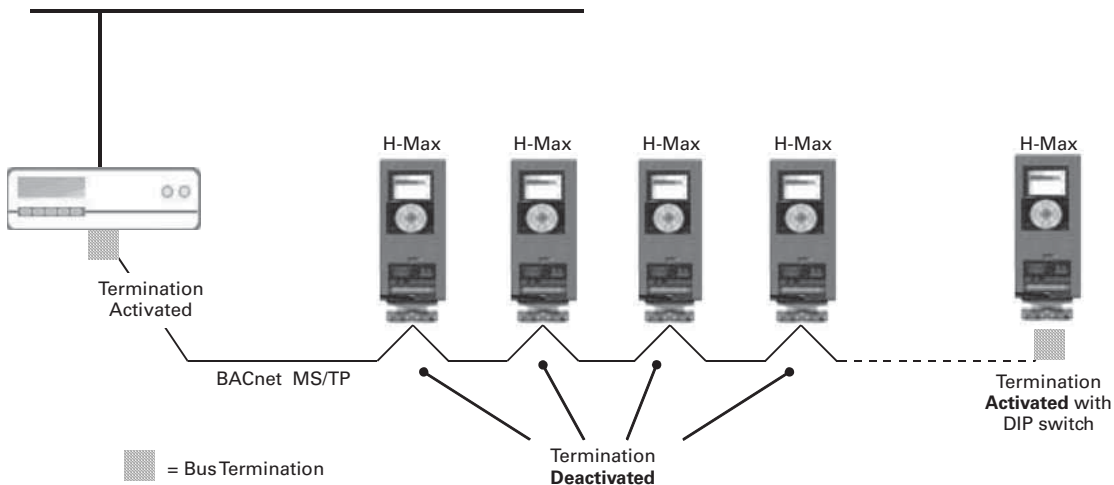

## BACnet Programming

The navigation path to the fieldbus parameters may differ from application to application. The exemplary paths below apply to the H-Max HVAC drive.

1. First ensure that the right fieldbus protocol is selected.

**Navigate:**

Main Menu > I/O and Hardware > RS-485

OR

Ethernet > Common settings > Protocol > Edit > (Choose protocol)

2. Select "*Fieldbus control*" as the *Remote Control Place*.

**Navigate:**

Main Menu > Parameters > Basic Parameters > START SRC AUTO

3. Choose source of reference.

**Navigate:**

Main Menu > Parameters > Basic Parameters > Speed Setup Auto (fieldbus)

4. Set fieldbus parameters.

**Navigate:**

Main Menu > I/O and Hardware > RS-485

OR

Ethernet > BACnet MSTP Settings

See next page.

**BACnet MS/TP Parameters and Monitoring Values (M4.7.3)**

**Parameters**

Code	Parameter	Min.	Max.	Unit	Default	ID	Description
<b>Parameters Related with BACnet Used Through MS/TP</b>							
P4.7.3.1.1	Baud rate	1	4	bd	1	—	Communication speed <b>1</b> = 9600 <b>2</b> = 19200 <b>3</b> = 38400 <b>4</b> = 76800
P4.7.3.1.2	Autobauding	0	1	—	1	—	Automatic baudrate detection <b>0</b> = Off <b>1</b> = On The automatically detected baud rate is then shown as value of parameter P4.7.3.1.1
P4.7.3.1.3	MAC address	1	127	—	1	—	—
P4.7.3.1.4	Instance number	0	65535	—	0	—	Device Object's instance number <b>0</b> = Automatically generated
P4.7.3.1.5	Communication time-out	0	65535	s	10	—	<b>0</b> = Not used

**Monitoring Values**

Code	Parameter	Min.	Max.	Unit	Default	ID	Description
<b>Monitoring Values Related with BACnet Used Through MS/TP</b>							
P4.7.3.2.1	Fieldbus protocol status	1	3	—	—	—	<b>1</b> = Stopped <b>2</b> = Operational <b>3</b> = Faulted
P4.7.3.2.2	Communication status	0.0	99.999	—	0.0	—	<b>0–99</b> = Number of messages with errors <b>0–999</b> = Number of messages without communication errors
P4.7.3.2.3	Actual instance number	0	65535	—	Serial number	—	Shows actual Device Object's instance number
P4.7.3.2.4	Fault code	0	3	—	0	—	<b>0</b> = None <b>1</b> = Sole Master <b>2</b> = Duplicate MAC ID <b>3</b> = Baud rate fault
P4.7.3.2.5	Control word	—	—	hex	—	—	See <b>Page 89</b>
P4.7.3.2.6	Status word	—	—	hex	—	—	See <b>Page 89</b>



**BACnet IP Parameters and Monitoring Values****Ethernet Common Settings (M4.8.1)**

Code	Parameter	Min.	Max.	Unit	Default	ID	Description
<b>Common Settings for BACnet IP</b>							
P4.8.1.1	IP address mode	—	—	—	—	—	See <b>Page 85</b>
P4.8.1.2	IP address	—	—	—	—	—	See <b>Page 85</b>
P4.8.1.3	Subnet mask	—	—	—	—	—	See <b>Page 85</b>
P4.8.1.4	Default gateway	—	—	—	—	—	See <b>Page 85</b>
P4.8.1.5	MAC address	—	—	—	—	—	See <b>Page 85</b>

**BACnet IP Settings**

Code	Parameter	Min.	Max.	Unit	Default	ID	Description
<b>Parameters Related with BACnet Used Through Ethernet</b>							
P4.8.3.1.1	Instance number	0	4194304	—	0	—	Device Object's instance number <b>0</b> = Serial number
P4.8.3.1.2	Communication time-out	0	65535	s	0	—	<b>0</b> = Not used
P4.8.3.1.3	Protocol in use	0	1	—	0	—	<b>0</b> = Not used <b>1</b> = Used

**Monitoring Values**

Code	Parameter	Min.	Max.	Unit	Default	ID	Description
<b>Monitoring Values Related with BACnet Used Through Ethernet</b>							
P4.8.3.2.1	Fieldbus protocol status	1	3	—	—	—	<b>1</b> = Stopped <b>2</b> = Operational <b>3</b> = Faulted
P4.8.3.2.2	Communication status	0.0	99.999	—	0.0	—	<b>0–99</b> = Number of messages with errors <b>0–999</b> = Number of messages without communication errors
P4.8.3.2.3	Actual instance number	0	65535	—	Serial number	—	Shows actual Device Object's instance number
P4.8.3.2.4	Control word	—	—	hex	—	—	See <b>Page 89</b>
P4.8.3.2.5	Status word	—	—	hex	—	—	See <b>Page 89</b>

## BACnet MS/TP Parameter Descriptions

### BACnet MS/TP Parameters

#### P4.7.3.1.1 Baud Rate

Select the communication speed for the network. The default value is 9600 baud. If value *Auto* is chosen this parameter is not editable.

#### P4.7.3.1.2 Autobauding

This function is set off by default. If the parameter is given value 1 the automatic baud rate detection is used. The automatically detected baud rate is then shown as value of parameter *P4.7.3.1.1 Baud Rate*.

#### P4.7.3.1.3 MAC Address

The parameters of every device must be set before connecting to the bus. Especially the parameters *MAC address* and *baud rate* must be the same as in the master's configuration.

The first parameter, MAC (Medium Access Control) address, must be unique on the network to which it is connected. The same MAC address may be used on a device on another network within the internetwork.

Addresses 128–254 are reserved for slaves. Addresses 1–127 are valid for both masters and slaves. The portion of the address space that is actually used for masters in a particular installation is determined by the value of the *Max\_Master* property of the device object.

It is recommended that MAC address 0 be reserved for use by the MS/TP router. 255 is reserved for broadcasts.

#### P4.7.3.1.4 Instance Number

The Device Object's Instance number must be unique across the entire BACnet internetwork because it is used to uniquely identify the BACnet devices. It may be used to conveniently identify the BACnet device from other devices during installation.

If 0 (default) is selected, the Device Instance number is read from Drive. This unique number is then shown in the Monitor menu. If any other value than zero is selected, the value is used as Device Object's Instance number. The actual value is shown in the Monitor menu. The default value for this parameter is generated from the Ethernet MAC address. Last 2 octets will be used. XX.XX.XX.XX.FF.FF.

#### P4.7.3.1.5 Communication Time-out

BACnet board initiates a communication error if the board is a "sole master" in the network for a time defined with this parameter. "0" means that no fault is generated.

### BACnet MS/TP Monitoring Values

#### P4.7.3.2.1 Fieldbus Protocol Status

*Fieldbus Protocol Status* tells the status of the protocol.

#### P4.7.3.2.2 Communication Status

The *Communication status* shows how many error and how many good messages the frequency converter has received. The Communication status includes a common error counter that counts CRC and parity errors and a counter for good messages.

Only messages to the current slave in use are counted in the good messages, not MS/TP token packages.

### BACnet MS/TP—Good Messages

Code	Description
0–999	Number of messages received without errors

### BACnet MS/TP—Bad Frames

Code	Description
0–99	Number of messages received with errors

#### P4.7.3.2.3 Actual Instance Number

Shows the actual instance number.

#### P4.7.3.2.4 Fault Code

Shows BACnet MS/TP fault codes.

#### P4.7.3.2.5 Control Word

Shows the *Control Word* received from the bus.

#### P4.7.3.2.6 Status Word

Shows the current *Status Word* that is sent to the bus.

## BACnet IP Parameter Descriptions

### Ethernet Common Settings

#### P4.8.1.1 IP Address Mode

Selectable alternatives are *DHCP* (Dynamic Host Configuration Protocol) and *Fixed*.

DHCP protocol gives IP addresses to new devices connecting to local network. This address is valid for a certain period of time.

A fixed IP address is specified manually and it does not change.

When the mode is changed from DHCP to Fixed the addresses will read

*IP:* 192.168.0.10  
*Subnet mask:* 0.0.0.0  
*Default gateway:* 0.0.0.0

#### P4.8.1.2 IP Address

An *IP address* is a series of numbers (like above) specific to the device connected to the Internet.

#### P4.8.1.3 Subnet Mask

The network mask marks all the bits of an IP address for the identification of the network and the subnetwork.

#### P4.8.1.4 Default Gateway

Gateway address is the IP address of a network point that acts as an entrance to another network.

#### P4.8.1.5 MAC Address

The MAC address of the control board.

MAC address (Media Access Control) is a unique address given to each network host.

### BACnet IP Settings

#### P4.8.3.1.1 Instance Number

Similar to BACnet MS/TP device object instance number (see [Page 84](#)).

#### P4.8.3.1.2 Communication Time-out

BACnet board initiates a communication error if the Ethernet connection is lost. Communication time-out parameters define the minimum delay between UDP packages received from the master. The timer is reset and started after each received UDP package. This parameter can be used if the master is periodically polling the slaves.

#### P4.8.3.1.3 Protocol In Use

BACnet/IP protocol can be enabled and disabled with this parameter. When the parameter value is set to "1" the BACnet/IP protocol is enabled and disabled when set to "0".

### IP Monitoring Values

#### P4.8.3.2.1 Fieldbus Protocol Status

Fieldbus Protocol Status tells the status of the protocol.

#### P4.8.3.2.2 Communication Status

The Communication status shows how many error and how many good messages the frequency converter has received. The Communication status includes a common error counter that counts CRC and parity errors and a counter for good messages.

### BACnet IP—Good Messages

Code	Description
0-999	Number of messages received without errors

### BACnet IP—Bad Frames

Code	Description
0-99	Number of messages received with errors

#### P4.8.3.2.3 Actual Instance Number

The Device Object's actual instance number. This monitoring value is needed when value 0 is written to parameter P4.8.3.1.1.

#### P4.8.3.2.3 Control Word

Shows the Control Word received from the bus.

#### P4.8.3.2.4 Status Word

Shows the current Status Word that is sent to the bus.

**BACnet Communications**

***Object Types and Properties Supported***

**Object Types and Properties Supported**

Property	Object Type		
	Device	Binary Value	Analog Value
Object Identifier	■	■	■
Object Name	■	■	■
Object Type	■	■	■
System Status	■	—	—
Vendor Name	■	—	—
Vendor Identifier	■	—	—
Model Name	■	—	—
Firmware Revision	■	—	—
Appl Software revision	■	—	—
Protocol Version	■	—	—
Protocol Revision	■	—	—
Services Supported	■	—	—
Object Types supported	■	—	—
Object List	■	—	—
Max APDU Length	■	—	—
Segmentation Support	■	—	—
APDU Timeout	■	—	—
Number ADPU Retries	■	—	—
Max Master	■	—	—
Max Info Frames	■	—	—
Device Address Binding	■	—	—
Database Revision	■	—	—
Preset Value	—	■	■
Status Flags	—	■	■
Event State	—	■	■
Out-of-Service	—	■	■
Units	—	—	■
Priority Array	—	■ <sup>1</sup>	■ <sup>1</sup>
Relinquish Default	—	■ <sup>1</sup>	■ <sup>1</sup>
Polarity	—	—	—
Active Text	—	■	—
Inactive Text	—	■	—

**Note**

<sup>1</sup> Only with commandable values

**Binary Value Object**

**Note:** Present Value Access Types: **R** = Read-only, **W** = Writeable, **C** = Commandable.  
Commandable values support priority arrays and relinquish defaults.

**Binary Value Object**

<b>Instance ID</b>	<b>Object Name</b>	<b>Description</b>	<b>Inactive/Active</b>	<b>Preset Value Access Type</b>
BV0	Ready State	StateIndicates whether the drive is ready or not	Not Ready / Ready	R
BV1	Run/Stop State	Indicates whether the drive is running or stopped	Stop / Run	R
BV2	Fwd/Rev State	Indicates the rotation direction of the motor	Fwd / Rev	R
BV3	Fault State	Indicates if a fault is active	OK / Fault	R
BV4	Warning State	Indicates if warning is active	OK / Alarm	R
BV5	At Setpoint	Ref. Frequency reached	False / True	R
BV6	At Zero Speed	Motor Running at zero speed	False / True	R
BV7	General status bit_0	General status bit_0	0 / 1	R
BV8	General status bit_1	General status bit_1	0 / 1	R
BV9	General status bit_2	General status bit_2	0 / 1	R
BV10	General status bit_3	General status bit_3	0 / 1	R
BV11	General status bit_4	General status bit_4	0 / 1	R
BV12	General status bit_5	General status bit_5	0 / 1	R
BV13	General status bit_6	General status bit_6	0 / 1	R
BV14	General status bit_7	General status bit_7	0 / 1	R
BV15	Run/Stop CMD	Command to start drive (FB control is active)	Stop / Run	C
BV16	Fwd/Rev CMD	Fwd/Rev	Fwd / Rev	C
BV17	Reset Fault	Command to reset Active Fault from drive	0 / Reset	C
BV18	Force Bypass	Set drive to bypass mode	0 / 1	C
BV19	DIN 3	Digital Input 3	0 / 1	C
BV20	DIN 4	Digital Input 4	0 / 1	C
BV21	DIN 5	Digital Input 5	0 / 1	C
BV22	DIN 6	Digital Input 6	0 / 1	C
BV23	Fixed Control Word Bit 8	Fixed Control Word Bit 8	0 / 1	C
BV24	Fixed Control Word Bit 9	Fixed Control Word Bit 9	0 / 1	C
BV25	RO1	Relay Output 1	0 / 1	C
BV26	RO2	Relay Output 2	0 / 1	C
BV27	RO3	Relay Output 3	0 / 1	C
BV28	Fire Mode	Activate Fire Mode	0 / 1	C
BV29	Setback	Set Drive to Defaults	0 / Setback	C
BV30	fb_control_word Bit_15	fb_control_word bit 15	0 / 1	C

## Communications

### Analog Value Object

**Note:** Present Value Access Types: **R** = Read-only, **W** = Writeable, **C** = Commandable.  
Commandable values support priority arrays and relinquish defaults.

High and Low limits for the objects are defined in the application. See corresponding application for exact limits.

### Analog Value Object

Instance ID	Object Name	Description	Inactive/Active	Preset Value Access Type
AV0	Frequency Setpoint	Frequency Setpoint	Hz	R
AV1	Output FrequencyOutput	Frequency	Hz	R
AV2	Motor Speed	Motor Speed	rpm	R
AV3	Load (power)	Motor Shaft Power	%	R
AV4	Kilowatt Hours total	Kilowatt Hour Counter (Total)	kWh	R
AV5	Motor Current	Motor Current	A	R
AV6	DC link Voltage	DC link Voltage	V	R
AV7	Motor Voltage	Motor Voltage	V	R
AV8	Unit Temperature	Heatsink Temperature	°C	R
AV9	Motor TorqueIn	% of motor nominal Torque	%	R
AV10	Operating Days	Operating Days (resettable)	Day	R
AV11	Operating Hours	Operating Hours (resettable)	Hour	R
AV12	Kilowatt Hours	Kilowatt Hours (resettable)	kWh	R
AV13	Torque Reference	Torque Reference	%	R
AV14	Temperature Rise	Calculated motor temperature 100.0% = nominal temperature of motor	%	R
AV15	fb_ProcessdataOut_01	Application specific	16 bit Resolution 1	R
AV16	fb_ProcessdataOut_02	Application specific	16 bit Resolution 1	R
AV17	fb_ProcessdataOut_03	Application specific	16 bit Resolution 1	R
AV18	fb_ProcessdataOut_04	Application specific	16 bit Resolution 1	R
AV19	fb_ProcessdataOut_05	Application specific	16 bit Resolution 1	R
AV20	fb_ProcessdataOut_06	Application specific	16 bit Resolution 1	R
AV21	fb_ProcessdataOut_07	Application specific	16 bit Resolution 1	R
AV22	fb_ProcessdataOut_08	Application specific	16 bit Resolution 1	R
AV23	Active Fault Code	Active Fault Code	-	R
AV24	Speed Reference	Speed Reference, percentage of nominal speed	%	C
AV25	Current Limit	Current Limit	A	W
AV26	Min Frequency	Minimum Frequency	Hz	W
AV27	Maximum Frequency	Maximum Frequency	Hz	W
AV28	Accel Time	Acceleration Time	s	W
AV29	Decel Time	Deceleration Time	s	W
AV30	fb_ProcessdataIn_01	Application specific	16 bits Resolution 1	C
AV31	fb_ProcessdataIn_02	Application specific	16 bits Resolution 1	C
AV32	fb_ProcessdataIn_03	Application specific	16 bits Resolution 1	C
AV33	fb_ProcessdataIn_04	Application specific	16 bits Resolution 1	C
AV34	AnyParam ID	ID number that is used in AV35	0 to 65535 resolution 1	W
AV35	AnyParam Value	Value of ID defined by AV34	32 bits Value	W
AV36 <sup>1</sup>	Fb_Control_Word Lo16	Fixed Control Word First 16 bits 0–15	16 bits Resolution 1	C
AV37 <sup>1</sup>	Fb_Control_Word Hi16	Fixed Control Word Last 16 bits 16–31	16 bits Resolution 1	C
AV38	Fb_Status_Word Lo16	Fixed Status Word First 16 bits 0–15	16 bits Resolution 1	R
AV39	Fb_Status_Word Hi16	Fixed Status Word Last 16 bits 16–31	16 bits Resolution 1	R

**Note**

<sup>1</sup> ANSI/IEEE-754 floating point. Binary coding can be done only if the value has no decimals.

**Control Word Bits****Control Word Bits**

<b>Bit</b>	<b>Name</b>	<b>Value = 1</b>	<b>Value = 0</b>	<b>Description</b>
B0	Start/Stop	Start request	Stop request	Start/Stop command to application
B2	Fault reset	Reset faults	No action	Command to reset fault
B3–B15	Not used	—	—	—

**Status Word Bits****Status Word Bits**

<b>Bit</b>	<b>Name</b>	<b>Value = 1</b>	<b>Value = 0</b>	<b>Description</b>
B0	Ready	Ready	Not ready	Indicates whether the drive is ready or not
B1	Run	Running	Stop	Indicates whether the drive is running or stopped
B2	Direction	Counterclockwise	Clockwise	Indicates the rotation direction of the motor
B3	Fault	Faulted	Not faulted	Indicates if a fault is active
B4	Alarm	Alarm	No alarm	Indicates if an alarm is active
B5	AtReference	True	False	Reference frequency reached
B6	ZeroSpeed	True	False	Motor running at zero speed
B7–B15	Not used	—	—	—

**BACnet Fault Tracing**

When an unusual operating condition is detected by the AC drive control diagnostics, the drive initiates a notification visible, for example, on the keypad. The keypad will show the ordinal number of the fault, the fault code and a short fault description.

The fault can be reset with the Reset button on the control keypad or via the I/O terminal. The faults are stored in the Fault history menu which can be browsed. The different fault codes you will find in the table below. This fault table presents only the faults related to the fieldbus in use.

**Note:** When contacting distributor or factory because of a fault condition, always write down all texts and codes on the keypad display. Call 877-ETN-Care (386-2273) (8am to 5pm EST) or email: TRC@Eaton.com with a description of the problem.

**Typical Fault Conditions**

**Typical Fault Conditions**

<b>Fault Condition</b>	<b>Possible Cause</b>	<b>Remedy</b>
Termination resistor	Missing or excessive termination resistor	Install termination resistors at both ends of the fieldbus line
Cabling	<ul style="list-style-type: none"> <li>• Supply or motor cables are located too close to the fieldbus cable</li> <li>• Wrong type of fieldbus cable</li> <li>• Too long cabling</li> </ul>	Correct cable routing
Grounding	Inadequate grounding	Ensure grounding in all points on the net
Connections	Faulty connections <ul style="list-style-type: none"> <li>• Excessive stripping of cables</li> <li>• Conductors in wrong terminals</li> <li>• Too loose connections of conductors</li> </ul>	Check for possible loose connections
Parameter	<ul style="list-style-type: none"> <li>• Faulty address</li> <li>• Overlapping slave addresses</li> <li>• Wrong baud rate</li> <li>• Wrong control place selected</li> </ul>	Check listed parameters for accuracy



**Other Fault Conditions**

The following fault tracing diagram will help you to locate and fix some of the most usual problems. If the problem persists contact your local distributor.

**Fault Tracing Diagram for BACnet MS/TP**

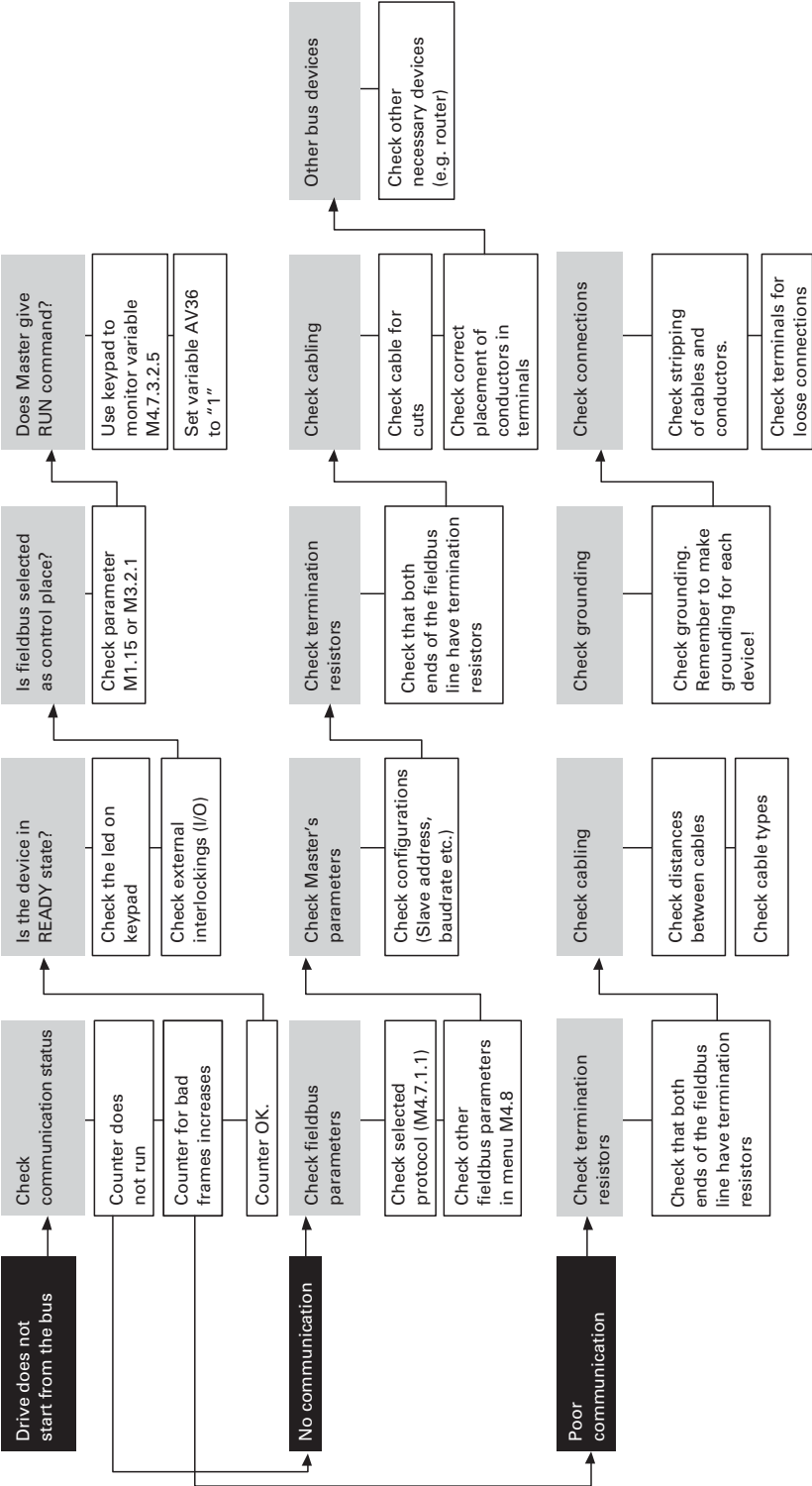

**Fault Tracing Diagram for BACnet IP**

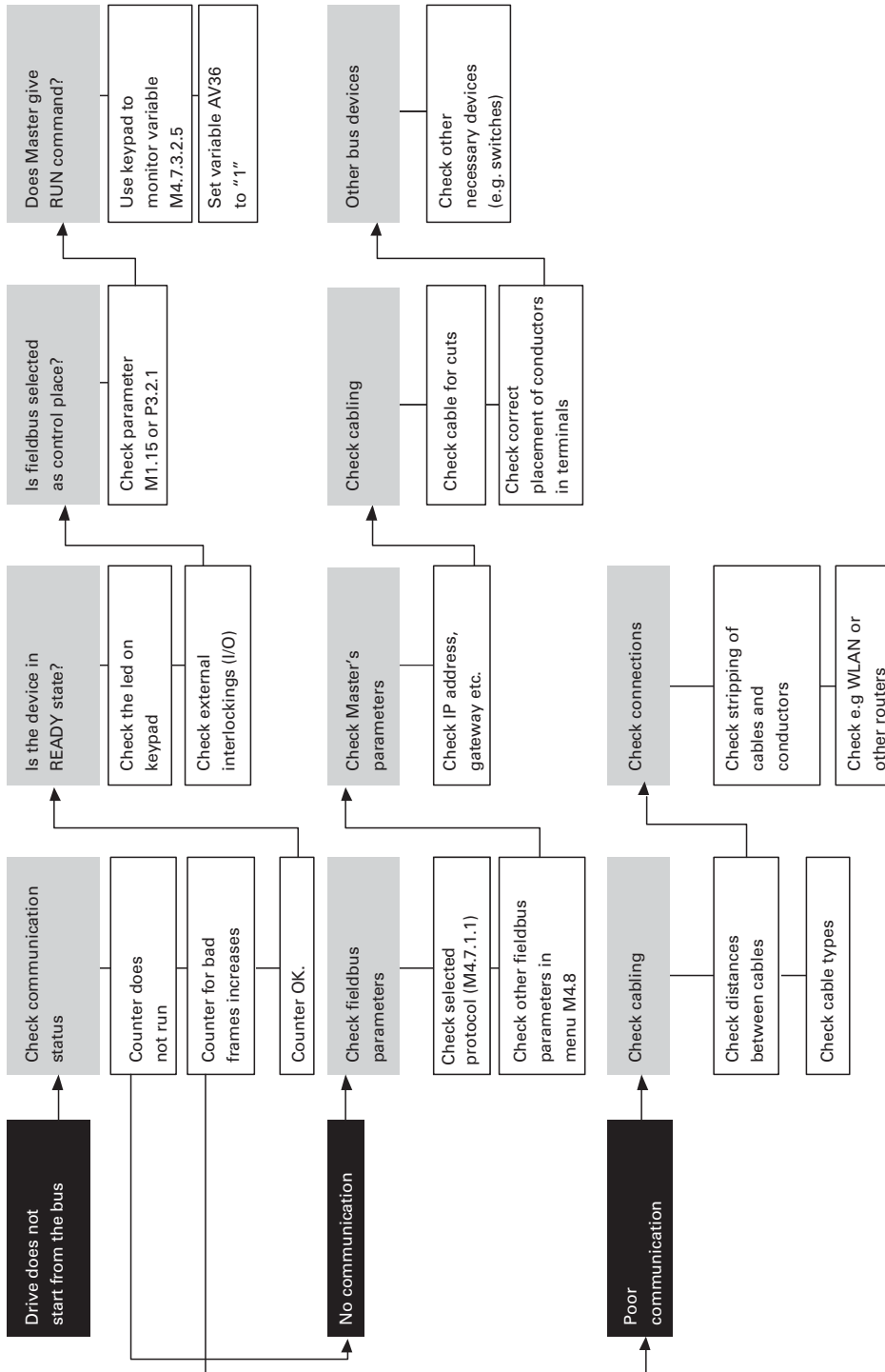

# Modbus Protocol

## Modbus General Information

Modbus is a communication protocol developed by Modicon systems. In simple terms, it is a way of sending information between electronic devices. The device requesting the information is called the Modbus Master (or the Client in Modbus TCP) and the devices supplying information are Modbus Slaves (in Modbus TCP servers). In a standard Modbus network, there is one Master and up to 247 Slaves, each with a unique Slave Address from 1 to 247. The Master can also write information to the Slaves. Modbus is typically used to transmit signals from instrumentation and control devices back to a main controller or data gathering system.

The Modbus communication interface is built around messages. The format of these Modbus messages is independent of the type of physical interface used. The same protocol can be used regardless of the connection type. Because of this, Modbus gives the possibility to easily up-grade the hardware structure of an industrial network, without the need for large changes in the software. A device can also communicate with several Modbus nodes at once, even if they are connected with different interface types, without the need to use a different protocol for every connection.

### Basic Structure of Modbus Frame

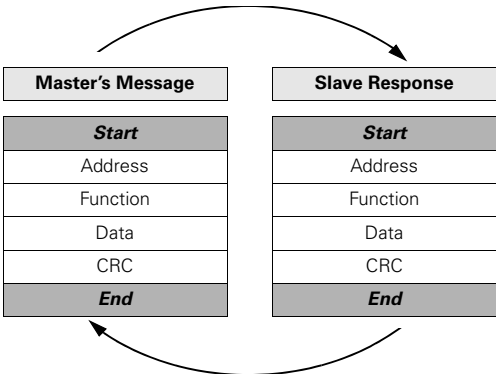

On simple interfaces like RS-485, the Modbus messages are sent in plain form over the network. In this case the network is dedicated to Modbus. When using more versatile network systems like TCP/IP over ethernet, the Modbus messages are embedded in packets with the format necessary for the physical interface. In that case Modbus and other types of connections can co-exist at the same physical interface at the same time. Although the main Modbus message structure is peer-to-peer, Modbus is able to function on both point-to-point and multidrop networks.

Each Modbus message has the same structure. Four basic elements are present in each message. The sequence of these elements is the same for all messages, to make it easy to parse the content of the Modbus message. A conversation is always started by a master in the Modbus network. A Modbus master sends a message and—depending of the contents of the message—a slave takes action and responds to it. There can be more masters in a Modbus network. Addressing in the message header is used to define which device should respond to a message. All other nodes on the Modbus network ignore the message if the address field doesn't match their own address.

Your H-Max HVAC drive is equipped with Modbus support as standard.

### Principal Example Diagram of Modbus

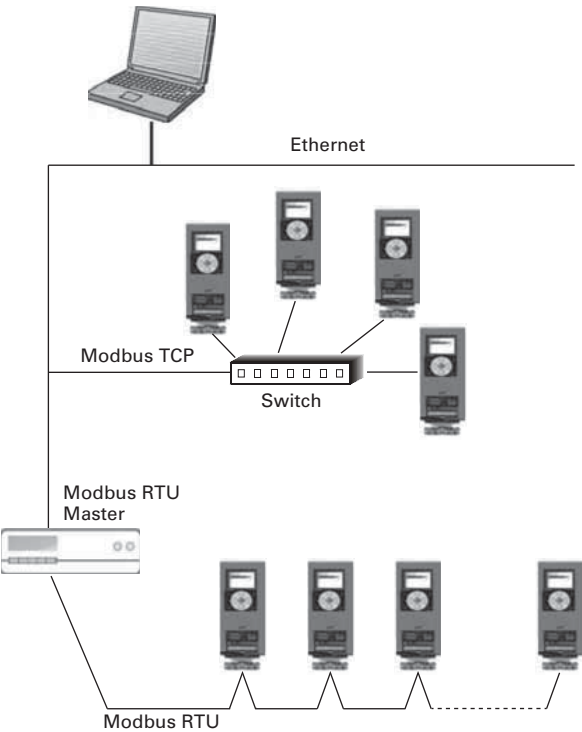

## Modbus Technical Data

### Modbus RTU Protocol

Connection	Communication
Interface	RS-485
Transfer cable	RS-485 MS/TP, half-duplex
Transfer cable	STP (Shielded Twisted Pair), type Belden 9841 or similar
Connector	2.5 mm <sup>2</sup>
Electrical isolation	Functional
Modbus RTU	As described in "Modicon Modbus Protocol Reference Guide"
Baud rate	300, 600, 1200, 2400, 4800, 9600, 19200, 38400 and 57600 baud
Addresses	1 to 247

### Modbus TCP Protocol

Connection	Communication
Interface	100BaseTX, IEEE 802.3 compatible
Data transfer method	Ethernet half-/full-duplex
Data transfer speed	10/100 MBit/s, autosensing
Protocol	Modbus TCP
Connector	Shielded RJ45 connector
Cable type	CAT5e STP
Protocol	As described in "Modbus Messaging Implementation Guide"
Default IP	Selectable: Fixed or DHCP (AutoIP)

## Modbus Installation

1. Open the cover of the AC drive.



### WARNING

**The relay outputs and other I/O-terminals may have a dangerous control voltage present even when H-Max is disconnected from mains.**

2. Locate the components that you will need on the AC drive to connect and run the Modbus cables.



### WARNING

**Be sure not to plug the Modbus TCP cable to the terminal under the keypad! This might harm your personal computer.**

**AC Drive Components (Modbus)**

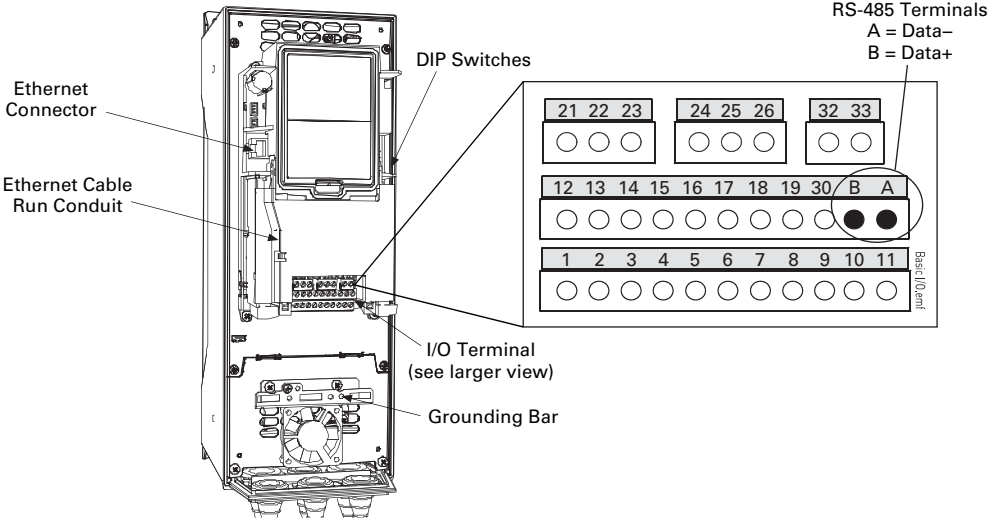

You can use the Modbus communication protocol through Ethernet and RS-485.

**Prepare For Use Through Ethernet**

1. Connect the Ethernet cable (see specification on **Page 94**) to its terminal and run the cable through the conduit as shown below.

**Modbus Ethernet Cable**

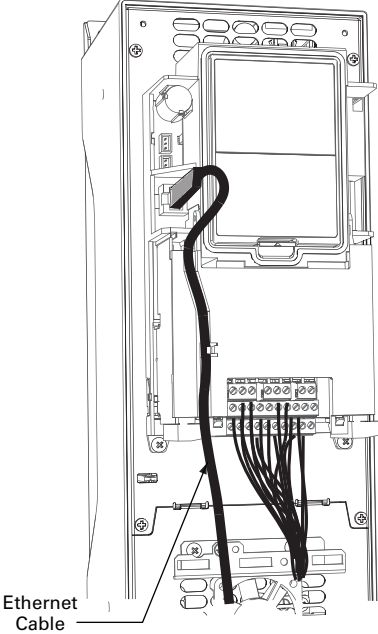

2. Remount the AC drive cover.

**Note:** When planning the cable runs, remember to keep the distance between the Ethernet cable and the motor cable at a **minimum of 11.81 in (30 cm)**.

**Prepare For Use Through RTU**

1. Strip about 0.59 in (15 mm) of the RS-485 cable (see specification on **Page 94**) and cut off the grey cable shield. Remember to do this for both bus cables (except for the last device).

Leave no more than 0.39 in (10 mm) of the cable outside the terminal block and strip the cables at about 0.20 in (5 mm) to fit in the terminals. See illustration below.

**RS-485 Cable Strip**

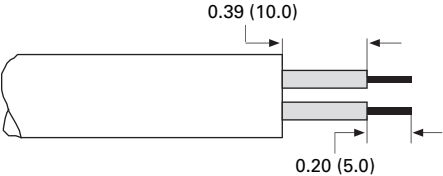

Also strip the cable now at such a distance from the terminal that you can fix it to the frame with the grounding clamp. Strip the cable at a maximum length of 0.59 in (15 mm).

**! IMPORTANT**

Do not strip the aluminum cable shield!

**RS-485 Cable Strip (Aluminum Shield)**

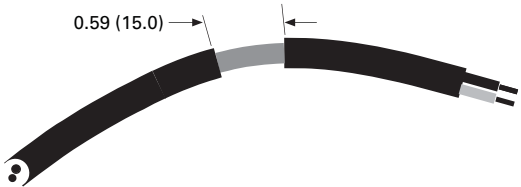

## Communications

- Then connect the cable to its appropriate terminals on H-Max AC drive standard terminal block, terminals **A and B** (A = negative, B = positive). See illustration below.

### H-Max AC Drive Terminals (Modbus)

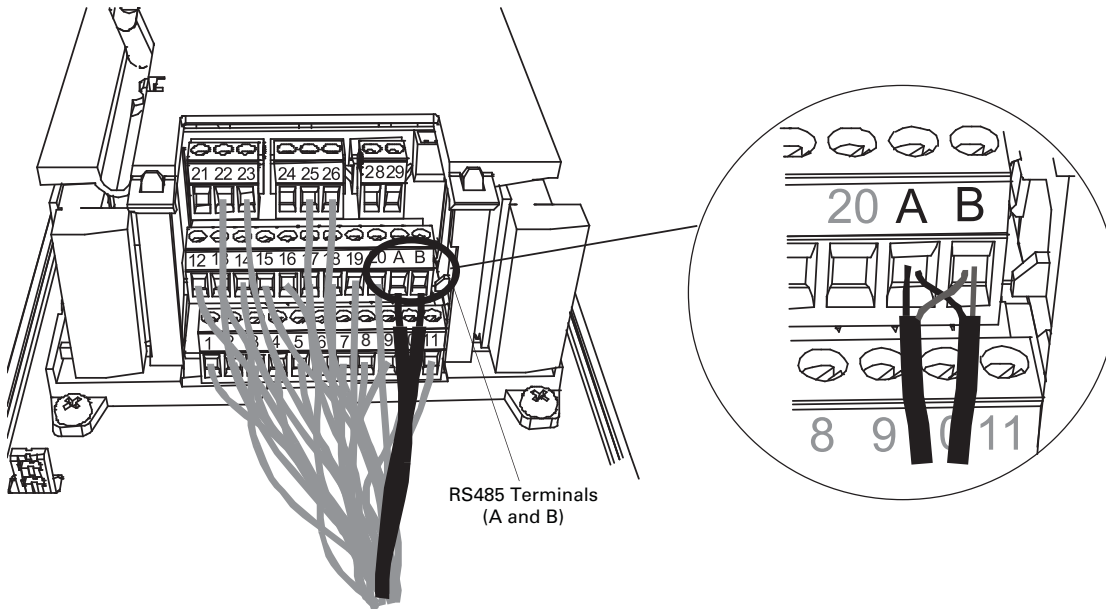

- Using the cable clamp included in the delivery of the drive, ground the shield of the RS-485 cable to the frame of the AC drive.

### RS-485 Ground

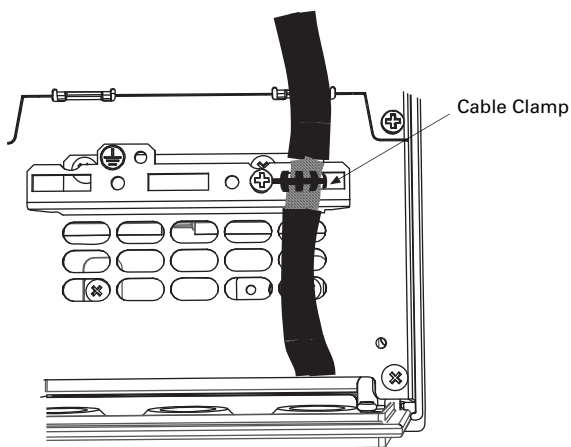

- 4. **If H-Max is the last device on the bus**, the bus termination must be set. Locate the DIP switches to the right of the control keypad of the drive and turn the switch for the RS-485 bus termination resistor to position ON. Biasing is built in the termination resistor. See also step 6 below.

**RS-485 Bus Termination Setup**

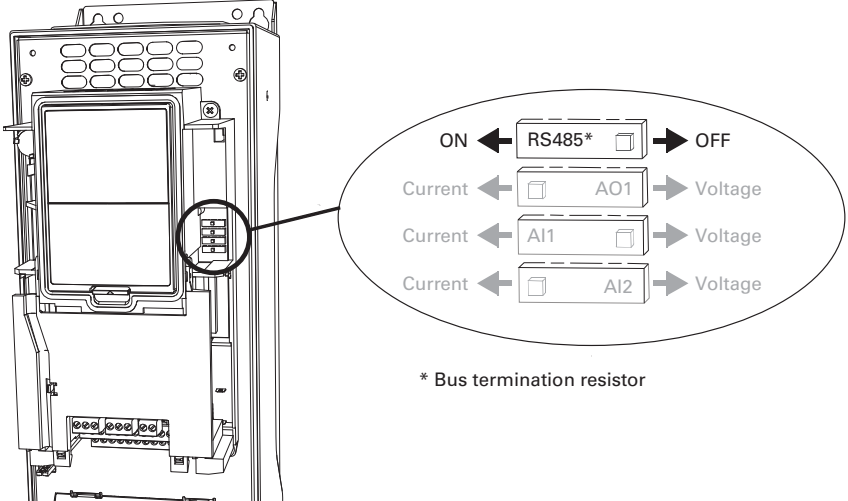

- 5. Remount the AC drive cover.
- Note:** When planning the cable runs, remember to keep the distance between the fieldbus cable and the motor cable at a **minimum of 11.81 in (30 cm)**.
- 6. The bus termination must be set for the first and last device of the fieldbus line. See illustration below. See also step 4 above. We recommend that the first device on the bus terminated is the Master device.

**Modbus RTU Bus Termination**

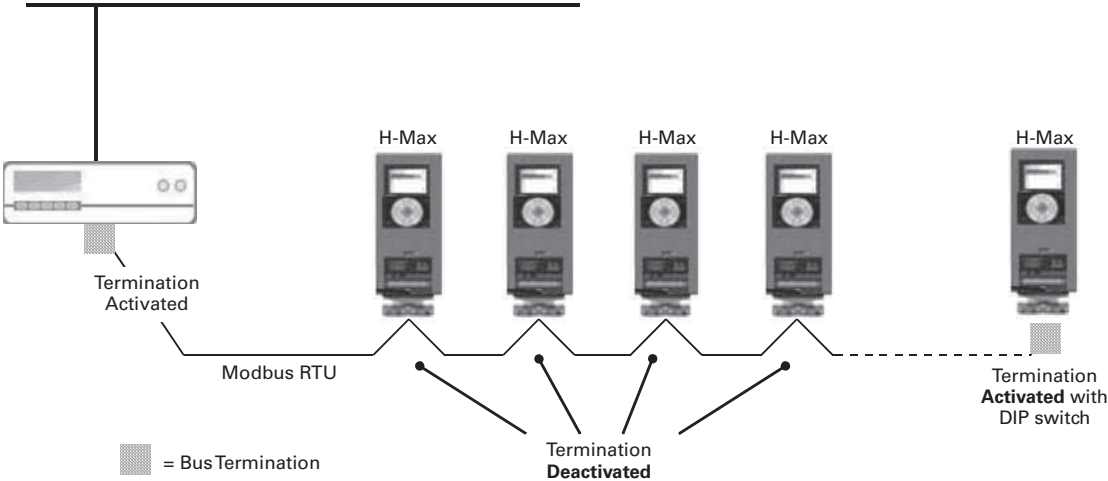

### Modbus Programming

The navigation path to the fieldbus parameters may differ from application to application. The exemplary paths below apply to the H-Max HVAC drive.

1. First ensure that the right fieldbus protocol is selected.

**Navigate:**

Main Menu > I/O and Hardware > RS-485

OR

Ethernet > Common settings > Protocol > Edit > (Choose protocol)

2. Select "*Fieldbus control*" as the *Remote Control Place*.

**Navigate:**

Main Menu > Parameters > Basic Parameters > START SRC AUTO

3. Choose source of reference.

**Navigate:**

Main Menu > Parameters > Basic Parameters > Speed Setup Auto (fieldbus)

4. Set fieldbus parameters.

**Navigate:**

Main Menu > I/O and Hardware > RS-485

OR

Ethernet > Modbus Settings

See next page.



**Modbus RTU Parameters and Monitoring Values****Parameters**

Code	Parameter	Min.	Max.	Unit	Default	ID	Description
<b>Parameters Related with Modbus Used Through RTU</b>							
P4.7.3.1.1	Slave address	1	247	—	1	—	Unique slave device address.
P4.7.3.1.2	Baud rate	1	9	bd	6	2236	Communication speed <b>1</b> = 300 <b>2</b> = 600 <b>3</b> = 1200 <b>4</b> = 2400 <b>5</b> = 4800 <b>6</b> = 9600 <b>7</b> = 19200 <b>8</b> = 38400 <b>9</b> = 57600
P4.7.3.1.3	Parity type	0	2	—	0	2239	<b>0</b> = None <b>1</b> = Odd <b>2</b> = Even
P4.7.3.1.4	Communication time-out	0	65535	s	10	—	<b>0</b> = Not used

**Monitoring Values**

Code	Parameter	Min.	Max.	Unit	Default	ID	Description
<b>Monitoring Values Related with Modbus Used Through RTU</b>							
P4.7.3.2.1	Fieldbus protocol status	1	3	—	1	—	<b>0</b> = Init <b>1</b> = Stopped <b>2</b> = Operational <b>3</b> = Faulted
P4.7.3.2.2	Communication status	0.0	99.999	—	0.0	—	<b>0–99</b> = Number of messages with errors <b>0–999</b> = Number of messages without communication errors
P4.7.3.2.3	Illegal functions	0	—	—	—	—	See <b>Page 101</b>
P4.7.3.2.4	Illegal data addresses	0	—	—	—	—	See <b>Page 101</b>
P4.7.3.2.5	Illegal data values	0	—	—	—	—	See <b>Page 101</b>
P4.7.3.2.6	Slave device busy	0	—	—	—	—	See <b>Page 101</b>
P4.7.3.2.7	Memory parity error	0	—	—	—	—	See <b>Page 101</b>
P4.7.3.2.8	Slave device failure	0	—	—	—	—	See <b>Page 101</b>
P4.7.3.2.9	Last fault response	0	—	—	—	—	See <b>Page 101</b>
P4.7.3.2.10	Control word	—	—	hex	—	—	See <b>Page 105</b>
P4.7.3.2.11	Status word	—	—	hex	—	—	See <b>Page 106</b>

## Modbus TCP Parameters and Monitoring Values

### Ethernet Common Settings (M4.8.1)

#### Common Settings for Modbus TCP (Ethernet)

Code	Parameter	Min.	Max.	Unit	Default	ID	Description
<b>Common Settings for BACnet IP</b>							
P4.8.1.1	IP address mode	—	—	—	—	—	See <b>Page 102</b>
P4.8.1.2	IP address	—	—	—	—	—	See <b>Page 102</b>
P4.8.1.3	Subnet mask	—	—	—	—	—	See <b>Page 102</b>
P4.8.1.4	Default gateway	—	—	—	—	—	See <b>Page 102</b>
P4.8.1.5	MAC address	—	—	—	—	—	See <b>Page 102</b>

#### Modbus TCP Settings

Code	Parameter	Min.	Max.	Unit	Default	ID	Description
<b>Parameters Related with Modbus Used Through Ethernet (Common Settings)</b>							
P4.8.2.1.1	Connection limit	0	2	—	2	—	Number of allowed connections
P4.8.2.1.2	Unit identifier number	0	255	—	1	—	See <b>Page 102</b>
P4.8.2.1.3	Communication time-out	0	65535	s	0	—	<b>0</b> = Not used

#### Monitoring Values

Code	Parameter	Min.	Max.	Unit	Default	ID	Description
<b>Monitoring Values Related with Modbus Used Through Ethernet (Connection 1, Monitoring) <sup>1</sup></b>							
P4.8.2.2.1.1	Fieldbus protocol status	1	3	—	—	—	<b>1</b> = Stopped <b>2</b> = Operational <b>3</b> = Faulted
P4.8.2.2.1.2	Communication status	0.0	99.999	—	0.0	—	<b>0–99</b> = Number of messages with errors <b>0–999</b> = Number of messages without communication errors
P4.8.2.2.1.3	Illegal functions	0	—	—	—	—	See <b>Page 101</b>
P4.8.2.2.1.4	Illegal data addresses	0	—	—	—	—	See <b>Page 101</b>
P4.8.2.2.1.5	Illegal data values	0	—	—	—	—	See <b>Page 101</b>
P4.8.2.2.1.6	Slave device busy	0	—	—	—	—	See <b>Page 101</b>
P4.8.2.2.1.7	Memory parity error	0	—	—	—	—	See <b>Page 101</b>
P4.8.2.2.1.8	Slave device failure	0	—	—	—	—	See <b>Page 101</b>
P4.8.2.2.1.9	Last fault response	0	—	—	—	—	See <b>Page 101</b>
P4.8.2.2.1.10	Control word	—	—	hex	—	—	See <b>Page 101</b>
P4.8.2.2.1.11	Status word	—	—	hex	—	—	See <b>Page 101</b>

#### Parameters Related with Modbus Used Through Ethernet (Connection 2, Monitoring) <sup>1</sup>

All parameters are the same as those for Connection 1.

#### Note

<sup>1</sup> Will appear only after connection has been established.

## Modbus RTU Parameter Descriptions

### Modbus RTU Parameters

#### P4.7.3.1.1 Slave Address

Each slave must have a unique address (from 1 to 247) so that it can be addressed independently from other nodes.

#### P4.7.3.1.2 Baud Rate

Select the communication speed for the network. The default value is 9600 baud.

#### P4.7.3.1.3 Parity Type

Users can select the parity type for the network.

#### Parity Type

Parity Type	Stopbits
Even	1
Odd	1
None	2

#### P4.7.3.1.4 Communication Time-Out

Modbus board initiates a communication error for a time defined with this parameter. "0" means that no fault is generated.

### Modbus RTU Monitoring Values

#### P4.7.3.2.1 Fieldbus Protocol Status

*Fieldbus Protocol Status* tells the status of the protocol.

#### FB Protocol Statuses

Item	Status
INITIALIZING	Protocol is starting up
STOPPED	Protocol is timeouted or not used
OPERATIONAL	Protocol is running
FAULTED	Major fault in protocol, requires restarting. If fault remains call 877-ETN-Care (386-2273) (8am to 5pm EST) or email: TRC@Eaton.com with a description of the problem

#### P4.7.3.2.2 Communication Status

The *Communication status* shows how many error and how many good messages the frequency converter has received. The Communication status includes a common error counter that counts CRC and parity errors and a counter for good messages.

Only messages to the current slave in use are counted in the good messages.

#### Modbus RTU—Good Messages

Code	Description
0–999	Number of messages received without errors

#### Modbus RTU—Bad Frames

Code	Description
0–99	Number of messages received with errors

#### P4.7.3.2.3 Illegal Functions

The function code received in the query refers to an unallowed action for the server (or slave).

#### P4.7.3.2.4 Illegal Data Addresses

The data address received in the query refers to an unallowed address for the server (or slave).

#### P4.7.3.2.5 Illegal Data Values

A value contained in the query data field refers to an unallowed value for server (or slave).

#### P4.7.3.2.6 Slave Device Busy

The server (or slave) is engaged in processing a long-duration program command. The client (or master) should retransmit the message later when the server (or slave) is free.

#### P4.7.3.2.7 Memory Parity Error

The server (or slave) attempted to read record file but detected a parity error in the memory.

#### P4.7.3.2.8 Slave Device Failure

An unrecoverable error occurred while the server (or slave) was attempting to perform the requested action.

#### P4.7.3.2.9 Last Fault Response

Shows the last fault response as *Fault code*.

#### P4.7.3.2.10 Control Word

Shows the *Control Word* received from the bus.

#### P4.7.3.2.11 Status Word

Shows the current *Status Word* that is sent to the bus.

## Modbus TCP Parameter Descriptions

### Ethernet Common Settings

#### P4.8.1.1 IP Address Mode

Selectable alternatives are *DHCP* (Dynamic Host Configuration Protocol) and *Fixed*.

DHCP protocol gives IP addresses to new devices connecting to local network. This address is valid for a certain period of time. If no DHCP server is found an automatic random IP is given.

A fixed IP address is specified manually and it does not change.

When the mode is changed from DHCP to Fixed the addresses will read

*IP:* 192.168.0.10  
*Subnet mask:* 0.0.0.0  
*Default gateway:* 0.0.0.0

#### P4.8.1.2 IP Address

An *IP address* is a series of numbers (like above) specific to the device connected to the Internet.

#### P4.8.1.3 Subnet Mask

The network mask marks all the bits of an IP address for the identification of the network and the subnetwork.

#### P4.8.1.4 Default Gateway

Gateway address is the IP address of a network point that acts as an entrance to another network.

#### P4.8.1.5 Mac Address

The MAC address of the control board.

MAC address (Media Access Control) is a unique address given to each network host. It is not editable.

### Modbus TCP Settings

#### Common Settings

##### P4.8.2.1.1 Connection Limit

Defines how many clients can access the server simultaneously.

##### P4.8.2.1.2 Unit Identifier Number

The Modbus "slave address" field usually used on Modbus Serial Line is replaced by a single byte "Unit Identifier".

On TCP/IP, the Modbus server is addressed using its IP address; therefore, the Modbus Unit Identifier is useless.

##### P4.8.2.1.3 Communication Time-out

Modbus board initiates a communication error if the Ethernet connection is lost. Communication time-out parameters define the minimum delay between packages received from the client. The timer is reset and started after each received package. This parameter can be used if the client is periodically polling the slaves.

### Modbus TCP Monitoring Values

These values will not appear before the connection is established.

#### Connection 1

##### P4.8.2.2.1.1 Fieldbus Protocol Status

Fieldbus Protocol Status tells the status of the protocol.

#### FB Protocol Statuses

Item	Status
INITIALIZING	Protocol is starting up
STOPPED	Protocol is timed out or not used
OPERATIONAL	Protocol is running
FAULTED	Major fault in protocol, requires restarting. If fault remains call 877-ETN-Care (386-2273) (8am to 5pm EST) or email: TRC@Eaton.com with a description of the problem

##### P4.8.2.2.1.2 Communication Status

The Communication status shows how many error and how many good messages the frequency converter has received. The Communication status includes a common error counter that counts errors and a counter for good messages.

#### Modbus TCP—Good Messages

Code	Description
0-999	Number of messages received without errors

#### Modbus TCP—Bad Frames

Code	Description
0-99	Number of messages received with errors

##### P4.8.2.2.1.3 Illegal Functions

The function code received in the query refers to an unallowed action for the server (or slave).

##### P4.8.2.2.1.4 Illegal Data Addresses

The data address received in the query refers to an unallowed address for the server (or slave).

##### P4.8.2.2.1.5 Illegal Data Values

A value contained in the query data field refers to an unallowed value for server (or slave).

##### P4.8.2.2.1.6 Slave Device Busy

The server (or slave) is engaged in processing a long-duration program command. The client (or master) should retransmit the message later when the server (or slave) is free.

**P4.8.2.2.1.7 Memory Parity Error**

The server (or slave) attempted to read record file but detected a parity error in the memory.

**P4.8.2.2.1.8 Slave Device Failure**

An unrecoverable error occurred while the server (or slave) was attempting to perform the requested action.

**P4.8.2.2.1.9 Last Fault Response**

Shows the last fault response as *Fault code*.

**P4.8.2.2.1.10 Control Word**

Shows the Control Word received from the bus.

**P4.8.2.2.1.11 Status Word**

Shows the current Status Word that is sent to the bus.

**Connection 2**

The monitoring values are the same as those for Connection 1 (see **Page 102**), only with a different code (P4.8.2.3.1.X).

**Modbus Communications**

**Features of the Modbus H-Max Interface:**

- Direct control of H-Max drive (such as Run, Stop, Direction, Speed reference, Fault reset)
- Full access to all H-Max parameters
- Monitor H-Max status (such as Output frequency, Output current, Fault code)

**Data Addresses in Modbus Messages**

All data addresses in Modbus messages are referenced to zero. The first occurrence of a data item is addressed as item number zero. For example:

- The coil known as “Coil 1” in a programmable controller is addressed as “Coil 0000” in the data address field of a Modbus message
- Coil 127 decimal is addressed as “Coil 007E hex” (126 decimal)
- Holding register 40001 is addressed as register 0000 in the data address field of the message. The function code field already specifies a “holding register” operation. Therefore the “4XXXX” reference is implicit
- Holding register 40108 is addressed as register 006B hex (107 decimal)

**Modbus Memory Map**

The Eaton variables and fault codes as well as the parameters can be read and written from Modbus. The parameter addresses are determined in the application. Every parameter and actual value have been given an ID number in the application. The ID numbering of the parameter as well as the parameter ranges and steps can be found in the application manual in question. The parameter value shall be given without decimals. If several parameters/actual values are read with one message, the addresses of the parameters/actual values must be consecutive.

**Supported Functions**

Function Code	Current Terminology	Access Type	Address Range (hex)	TCP/RTU
1 (0x01)	Read coils	Discrete	00000-0FFFF	TCP
2 (0x02)	Read Input Discrete	Discrete	10000-1FFFF	TCP
3 (0x03)	Read holding registers	16bit	40000-4FFFF	TCP&RTU
4 (0x04)	Read input registers	16bit	30000-3FFFF	TCP&RTU
5 (0x05)	Force single coils	Discrete	00000-0FFFF	TCP
6 (0x06)	Write single register	16bit	40000-4FFFF	TCP&RTU
15 (0x0F)	Force multiple coils	Discrete	00001-0FFFF	TCP
16 (0x10)	Write multiple registers	16bit	40000-4FFFF	TCP&RTU
23 (0x17)	Read/Write multiple registers	16bit	40000-4FFFF	TCP&RTU

**Note:** Broadcasting not supported in TCP. Broadcast supported with function code 06 and 16 in RTU.

## Modbus Data Mapping

### Coil Registers

Coil registers contain binary data (Read/Write). See **Page 105**.

#### Defined Coil Registers

Address	Function	Purpose
0001	RUN/STOP	Control Word, bit 0
0002	Direction	Control Word, bit 1
0003	Fault reset	Control Word, bit 2

### Input Discrete Registers

Input discrete registers contain binary data (Read). See **Page 106**.

#### Defined Input Discrete

Address	Function	Purpose
10001	Ready	Status Word, bit 0
10002	Run	Status Word, bit 1
10003	Direction	Status Word, bit 2
10004	Fault	Status Word, bit 3
10005	Alarm	Status Word, bit 4
10006	At reference	Status Word, bit 5
10007	Zero speed	Status Word, bit 6
10008	Flux ready	Status Word, bit 7

### Holding and Input Registers

All values can be read with function codes 3 and 4 (all registers are 3X and 4X reference). Modbus registers are mapped to drive IDs as follows:

#### Defined Input Holding Registers

Address Range	Purpose	Access Type	See ...
0001–2000	Eaton Application IDs	16-bit	Below
2001–2050	FBProcessDataIN	16-bit	<b>Page 105</b>
2051–2099	FBProcessDataIN	32-bit	<b>Page 105</b>
2101–2150	FBProcessDataOUT	16-bit	<b>Page 106</b>
2151–2199	FBProcessDataOUT	32-bit	<b>Page 106</b>
2200–10000	Eaton Application IDs	16-bit	Below
10501–10530	IDMap	16-bit	<b>Page 107</b>
10601–10630	IDMap Read/Write	16-bit	<b>Page 107</b>
10701–10760	IDMap Read/Write	16-bit	<b>Page 107</b>
20001–40000	Eaton Application IDs	16-bit	Below
40001–40007	Operation day counter	16-bit	<b>Page 107</b>
40101–40107	Resettable operation day counter	16-bit	<b>Page 107</b>
40201–40203	Energy counter	16-bit	<b>Page 107</b>
40301–40303	Resettable energy counter	16-bit	<b>Page 107</b>
40401–40430	Fault history	16-bit	<b>Page 108</b>

### Eaton Application IDs

Application IDs are parameters that depend on the frequency converter's application. These parameters can be read and written by pointing the corresponding memory range directly or by using the so-called ID map (more information below). It is easiest to use a straight address

if you want to read a single parameter value or parameters with consecutive ID numbers. It is possible to read 12 consecutive ID addresses.

#### Parameter IDs

Address	Purpose	ID
0001–2000	Application parameters	1–2000
2200–10000	Application parameters	2200–10000

### FB Process Data IN

The process data fields are used to control the drive (such as Run, Stop, Reference, Fault Reset) and to quickly read actual values (such as Output frequency, Output current, Fault code). The fields are structured as follows:

#### Process Data Master -> Slave (max 22 bytes)

#### Fieldbus Process Data IN

##### Address

16-bit <sup>1</sup>	32-bit	Name	Range/Type
2001	2051 = High data; 2052 = Low data	FB Control Word	Binary coded
2002	—	Reserved	Binary coded
2003	2053 = High data; 2054 = Low data	FB Speed Reference	0...10000 %
2004	2055 = High data; 2056 = Low data	FB Process Data In 1	See <b>Page 114</b>
2005	2057 = High data; 2058 = Low data	FB Process Data In 2	See <b>Page 114</b>
2006	2059 = High data; 2060 = Low data	FB Process Data In 3	See <b>Page 114</b>
2007	2061 = High data; 2062 = Low data	FB Process Data In 4	See <b>Page 114</b>
2008	2063 = High data; 2064 = Low data	FB Process Data In 5	See <b>Page 114</b>
2009	2065 = High data; 2066 = Low data	FB Process Data In 6	See <b>Page 114</b>
2010	2067 = High data; 2068 = Low data	FB Process Data In 7	See <b>Page 114</b>
2011	2069 = High data; 2070 = Low data	FB Process Data In 8	See <b>Page 114</b>

##### Note

<sup>1</sup> In H-Max, the Control Word and the Status Word are formed of 32 bits. Only the initial 16 bits can be read in the 16-bit area.

### Control Word Bits

The Control word is composed of 32 bits. Meanings of bits are described below. Unused bits have to be set to zero.

#### Control Word Bits

Bit	Name	Value = 1	Value = 0	Description
B0	Start/Stop	Start request	Stop request	Start/Stop command to application
B1	Direction	Reverse	Forward	Command to change rotational direction
B2	Fault reset	Reset faults	No action	Command to reset fault
B3–B31	Not used	—	—	—

**FB Process Data OUT**  
**Process Data Slave -> Master (max 22 bytes)**

**Fieldbus Process Data OUT**

**Address**

<b>16-bit</b>	<b>32-bit</b>	<b>Name</b>	<b>Range/Type</b>
2101	2151 = High data; 2152 = Low data	FB Status Word	Binary coded
2102	—	Reserved	Binary coded
2103	2153 = High data; 2154 = Low data	FB Actual Speed	0...10000 %
2104	2155 = High data; 2156 = Low data	FB Process Data Out 1	See <b>Page 114</b>
2105	2157 = High data; 2158 = Low data	FB Process Data Out 2	See <b>Page 114</b>
2106	2159 = High data; 2160 = Low data	FB Process Data Out 3	See <b>Page 114</b>
2107	2161 = High data; 2162 = Low data	FB Process Data Out 4	See <b>Page 114</b>
2108	2163 = High data; 2164 = Low data	FB Process Data Out 5	See <b>Page 114</b>
2109	2165 = High data; 2166 = Low data	FB Process Data Out 6	See <b>Page 114</b>
2110	2167 = High data; 2168 = Low data	FB Process Data Out 7	See <b>Page 114</b>
2111	2169 = High data; 2170 = Low data	FB Process Data Out 8	See <b>Page 114</b>

**Status Word Bits**

The Status word is composed of 32 bits. The meanings of bits are described below.

**Status Word Bits B1–B28**

<b>Bit</b>	<b>Name</b>	<b>Value = 1</b>	<b>Value = 0</b>	<b>Description</b>
B0	Ready	Ready	Not ready	Indicates whether the drive is ready or not
B1	Run	Running	Stop	Indicates whether the drive is running or stopped
B2	Direction	Counterclockwise	Clockwise	Indicates the rotation direction of the motor
B3	Fault	Faulted	Not faulted	Indicates if a fault is active
B4	Alarm	Alarm	No alarm	Indicates if an alarm is active
B5	AtReference	True	False	Reference frequency reached
B6	ZeroSpeed	True	False	Motor running at zero speed
B7	FluxReady	True	False	Motor is magnetized
B8–B28	Not used	—	—	—

**Status Word Bits B29-B31 (Descriptions of Bit Connections)**

<b>B29 Control Place</b>	<b>B30 Control Place</b>	<b>B31 Control Place</b>	<b>Description</b>
0	0	1	Fieldbus
0	1	0	Keypad
0	1	1	PC tool
1	0	0	I/O terminals

The use of process data depends on the application. In a typical situation, the device is started and stopped with the ControlWord (CW) written by the Master and the Rotating speed is set with Reference (REF). With PD1...PD8 the device can be given other reference values (such as Torque reference).

With the StatusWord (SW) read by the Master, the status of the device can be seen. Actual Value (ACT) and PD1...PD8 show the other actual values.



**ID Map**

Using the ID map, you can read consecutive memory blocks that contain parameters whose IDs are not in a consecutive order. The address range 10501–10530 is called “IDMap”, and it includes an address map in which you can write your parameter IDs in any order. The address range 10601 to 10630 is called “IDMap Read/Write”, and it includes values for parameters written in the IDMap. As soon as one ID number has been written in the map cell 10501, the corresponding parameter value can be read and written in the address 10601, and so on.

**ID Map Initialization**

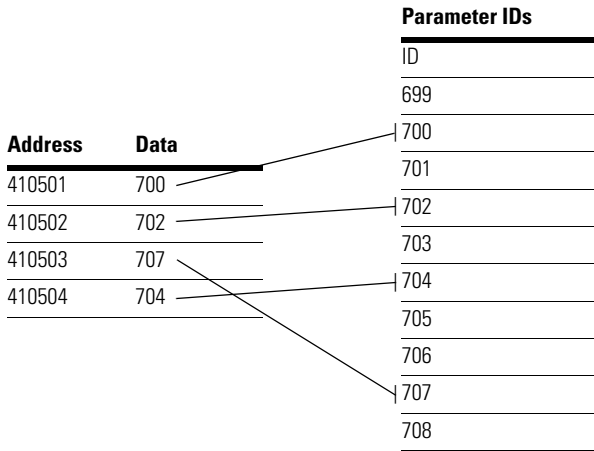

Once the IDMap address range has been initialized with any parameter ID number, the parameter value can be read and written in the IDMap Read/Write address range address IDMap address + 100.

**Parameter Values in 16-bit IDMap Read/Write Registers**

Address	Data
410601	Data included in parameter ID700
410602	Data included in parameter ID702
410603	Data included in parameter ID707
410604	Data included in parameter ID704

If the IDMap table has not been initialized, all fields show the index “0”. If it has been initialized, the parameter IDs included in it are stored in the flash memory of the OPT-CI board.

**Example of 32-Bit IDMap**

**Parameter Values in 32-Bit IDMap Read/Write Registers**

Address	Data
410701	Data High, parameter ID700
410702	Data Low, parameter ID700
410703	Data High, parameter ID702
410704	Data Low, parameter ID702

**Operation Day Counter**

**Operation Day Counter**

Address	Register	Purpose
40001	440001	Years
40002	440002	Days
40003	440003	Hours
40004	440004	Minutes
40005	440005	Seconds

**Resettable Operation Day Counter**

Reset the counter by writing “1” for parameter ID2311.

**Resettable Operation Day Counter**

Address	Register	Purpose
40101	440101	Years
40102	440102	Days
40103	440103	Hours
40104	440104	Minutes
40105	440105	Seconds

**Energy Counter**

The last number of the *Format* field indicates the decimal point place in the *Energy* field. If the number is bigger than 0, move the decimal point to the left by the number indicated. For example, Energy = 1200, Format = 52. Unit = 1. Energy = 12.00kWh.

**Energy Counter**

Address	Register	Purpose
40201	440201	Energy
40202	440202	Format
40203	440203	Unit <b>1</b> = kWh <b>2</b> = MWh <b>3</b> = GWh <b>4</b> = TWh

**Resettable Energy Counter**

Reset the counter by writing “1” for parameter ID2312.

**Resettable Energy Counter**

Address	Register	Purpose
40301	440301	Energy
40302	440302	Format
40303	440303	Unit <b>1</b> = kWh <b>2</b> = MWh <b>3</b> = GWh <b>4</b> = TWh

## Fault History

The fault history can be viewed by reading from address 40401 onward. The faults are listed in chronological order so that the latest fault is mentioned first and the oldest last. The fault history can contain 29 faults at the same time. The fault history contents are represented as follows.

## Fault History

Address	Register
40401	440401
40402	440402
40403	440403
...	...
40429	440429

## Example Messages

### Example 1

Write the process data 42001...42003 with command 16 (Preset Multiple Registers).

Command Master – Slave:

ADDRESS		01 hex Slave address 1 hex (= 1)
FUNCTION		10 hex Function 10 hex (= 16)
DATA	Starting address HI	07 hex Starting address 07D0 hex (= 2000)
	Starting address LO	D0 hex
	No. of registers HI	00 hex
	No. of registers LO	03 hex Number of registers 0003 hex (= 3)
	Byte count	06 hex Byte count 06 hex (= 6)
	Data HI	00 hex Data 1 = 0001 hex (= 1). Setting control word run bit to 1.
	Data LO	01 hex
	Data HI	00 hex Data 2 = 0000 hex (= 0).
	Data LO	00 hex
	Data HI	13 hex Data 3 = 1388 hex (= 5000), Speed Reference to 50.00%
	Data LO	88 hex
ERROR	CRC HI	C8 hex CRC field C8CB hex (= 51403)
CHECK	CRC LO	CB hex

Message frame:

01	10	07	D0	00	03	06	00	01	00	00	13	88	C8	CB
----	----	----	----	----	----	----	----	----	----	----	----	----	----	----

The reply to Preset Multiple Registers message is the echo of 6 first bytes.

Answer Slave – Master:

ADDRESS		01 hex Slave address 1 hex (= 1)
FUNCTION		10 hex Function 10 hex (= 16)
DATA	Starting address HI	07 hex Starting address 07D0 hex (= 2000)
	Starting address LO	D0 hex
	No. of registers HI	00 hex Number of registers 0003 hex (= 3)
	No. of registers LO	03 hex
ERROR	CRC HI	80 hex CRC 8085 hex (= 32901)
CHECK	CRC LO	85 hex

Reply frame:

01	10	07	D0	00	03	80	85
----	----	----	----	----	----	----	----

Example 2

Read the Process Data 42103...42104 with command 4 (Read Input Registers).

Command Master – Slave:

ADDRESS                    01 hex Slave address 1 hex (= 1)  
 FUNCTION                 04 hex Function 4 hex (= 4)  
 DATA        Starting address HI     08 hex  
               Starting address LO     36 hex  
               No. of registers HI     00 hex Number of registers 0002 hex (= 2)  
               No. of registers LO     02 hex  
 ERROR        CRC HI                 93 hex CRC field 93A5 hex (= 37797)  
 CHECK        CRC LO                 A5 hex

Message frame:

01	04	08	36	00	02	93	A5
----	----	----	----	----	----	----	----

The reply to the Read Input Registers message contains the values of the read registers.

Answer Slave – Master:

ADDRESS                    01 hex Slave address 1 hex (= 1)  
 FUNCTION                 04 hex Function 4 hex (= 4)  
 DATA        Byte count             04 hex Byte count 4 hex (= 4)  
               Data HI                 13 hex Speed reference = 1388 hex (=5000 => 50.00%)  
               Data LO                 88 hex  
               Data HI                 09 hex Output Frequency = 09C4 hex (=2500 =>25.00 Hz)  
               Data LO                 C4 hex CRC HI 78 hex  
 ERROR        CRC field             78E9 hex (=30953)  
 CHECK        CRC LO                 E9 hex

Reply frame:

01	04	04	13	88	09	C4	78	E9
----	----	----	----	----	----	----	----	----

## Communications

### Example of an Exception Response

In an exception response, the Slave sets the *most-significant bit* (MSB) of the function code to 1. The Slave returns an exception code in the data field.

Command Master – Slave:

ADDRESS		01 hex Slave address 1 hex (= 1)
FUNCTION		04 hex Function 4 hex (= 4)
DATA	Starting address HI	17 hex Starting address 1770 hex (= 6000)
	Starting address LO	70 hex
	No. of registers HI	00 hex Invalid number of registers 0005 hex (= 5)
	No. of registers LO	05 hex
ERROR	CRC HI	34 hex
CHECK	CRC LO	66 hex CRC field 3466 hex (=13414)

Message frame:

01	04	17	70	00	05	34	66
----	----	----	----	----	----	----	----

Exception response.

Answer Slave – Master:

ADDRESS	01 hex Slave address 1 hex (= 1)
FUNCTION	84 hex Most significant bit set to 1
ERROR CODE	04 hex Error code 04 => Slave Device Failure
ERROR CRC HI	42 hex CRC field 42C3 hex (= 17091)
CHECK CRC LO	C3 hex

Reply frame:

01	84	04	42	C3
----	----	----	----	----

### Modbus Fault Tracing

When an unusual operating condition is detected by the AC drive control diagnostics, the drive initiates a notification visible, for example, on the keypad. The keypad will show the ordinal number of the fault, the fault code and a short fault description.

The fault can be reset with the Reset button on the control keypad or via the I/O terminal. The faults are stored in the Fault history menu which can be browsed. The different fault codes you will find in the table below. This fault table presents only the faults related to the fieldbus in use.

**Note:** When contacting distributor or factory because of a fault condition, always write down all texts and codes on the keypad display. Call 877-ETN-Care (386-2273) (8am to 5pm EST) or email: TRC@Eaton.com with a description of the problem.

### Typical Fault Conditions

#### Typical Fault Conditions

Fault Condition	Possible Cause	Remedy
Termination resistor	Missing or excessive termination resistor.	Install termination resistors at both ends of the fieldbus line
Cabling	<ul style="list-style-type: none"> <li>Supply or motor cables are located too close to the fieldbus cable</li> <li>Wrong type of fieldbus cable</li> <li>Too long cabling</li> </ul>	Correct cable routing
Grounding	Inadequate grounding.	Ensure grounding in all points on the net
Connections	Faulty connections. <ul style="list-style-type: none"> <li>Excessive stripping of cables</li> <li>Conductors in wrong terminals</li> <li>Too loose connections of conductors</li> </ul>	Check for possible loose connections
Parameter	<ul style="list-style-type: none"> <li>Faulty address</li> <li>Overlapping slave addresses</li> <li>Wrong baud rate</li> <li>Wrong control place selected</li> </ul>	Check listed parameters for accuracy

### RS-485 Bus Biasing

When none of the devices on the RS-485 bus is sending data all devices are in idle status. This being the case, the bus voltage is in indefinite state, usually near 0V due to the termination resistors. This may cause problems in character reception because the single characters in serial communication begin with start bit referring to bus status "0" with voltage of less than 200mV whereas the bus status "1" corresponds to bus voltage of more than +200mV. The RS-485 standard considers the voltage interval -200mV...+200mV as undefined state. Bus biasing is therefore needed to maintain the voltage in status "1" (above +200mV) also between the messages.

To bias the bus you will have to add a separate active termination resistor specifically designed for the RS-485 bus (such as Siemens active RS 485 terminating element [6ES7972-0DA00-0AAA]).

**Other Fault Conditions**

The following fault tracing diagram will help you to locate and fix some of the most usual problems. If the problem persists contact your local distributor.

**Fault Tracing Diagram for Modbus RTU**

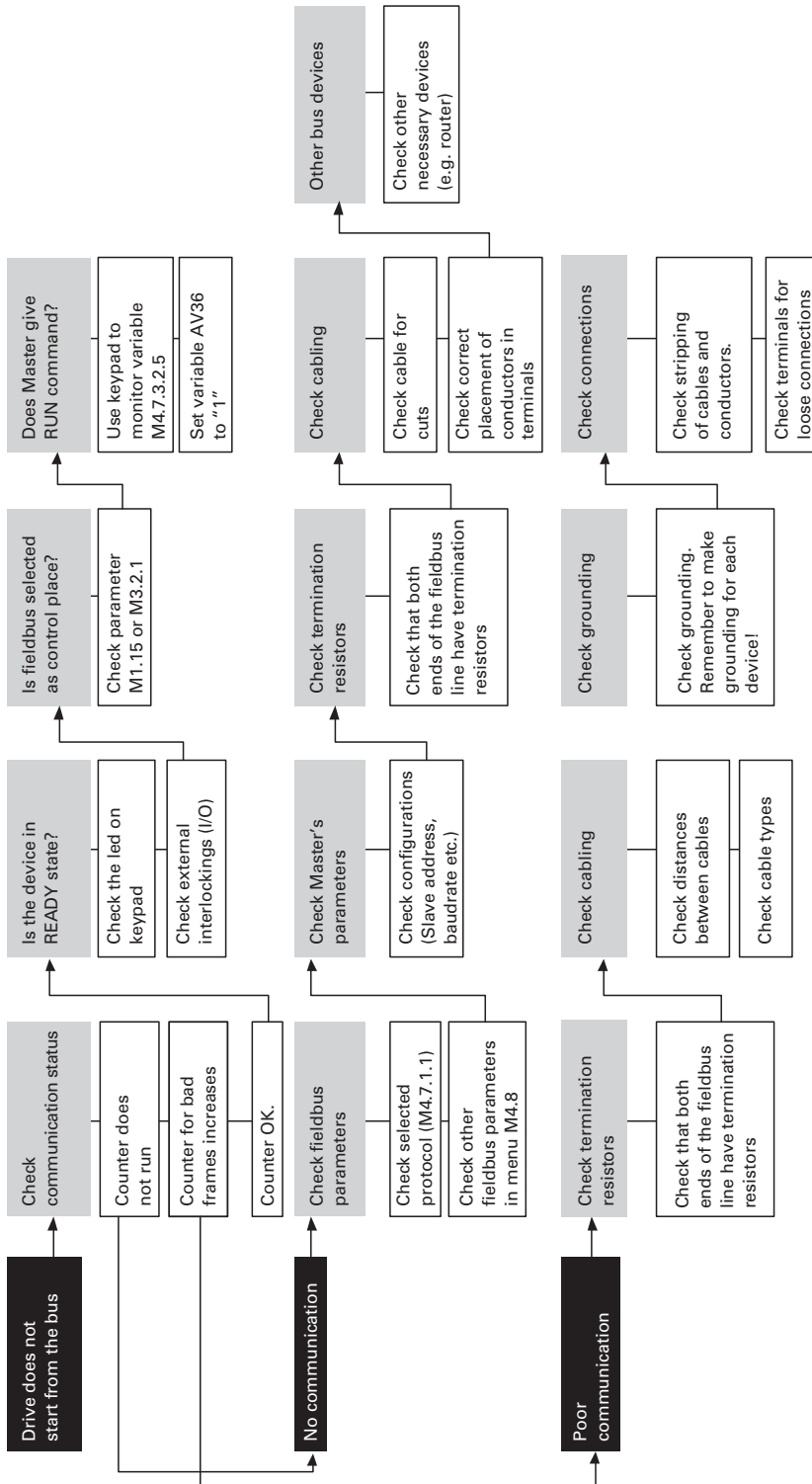

### Fault Tracing Diagram for Modbus TCP

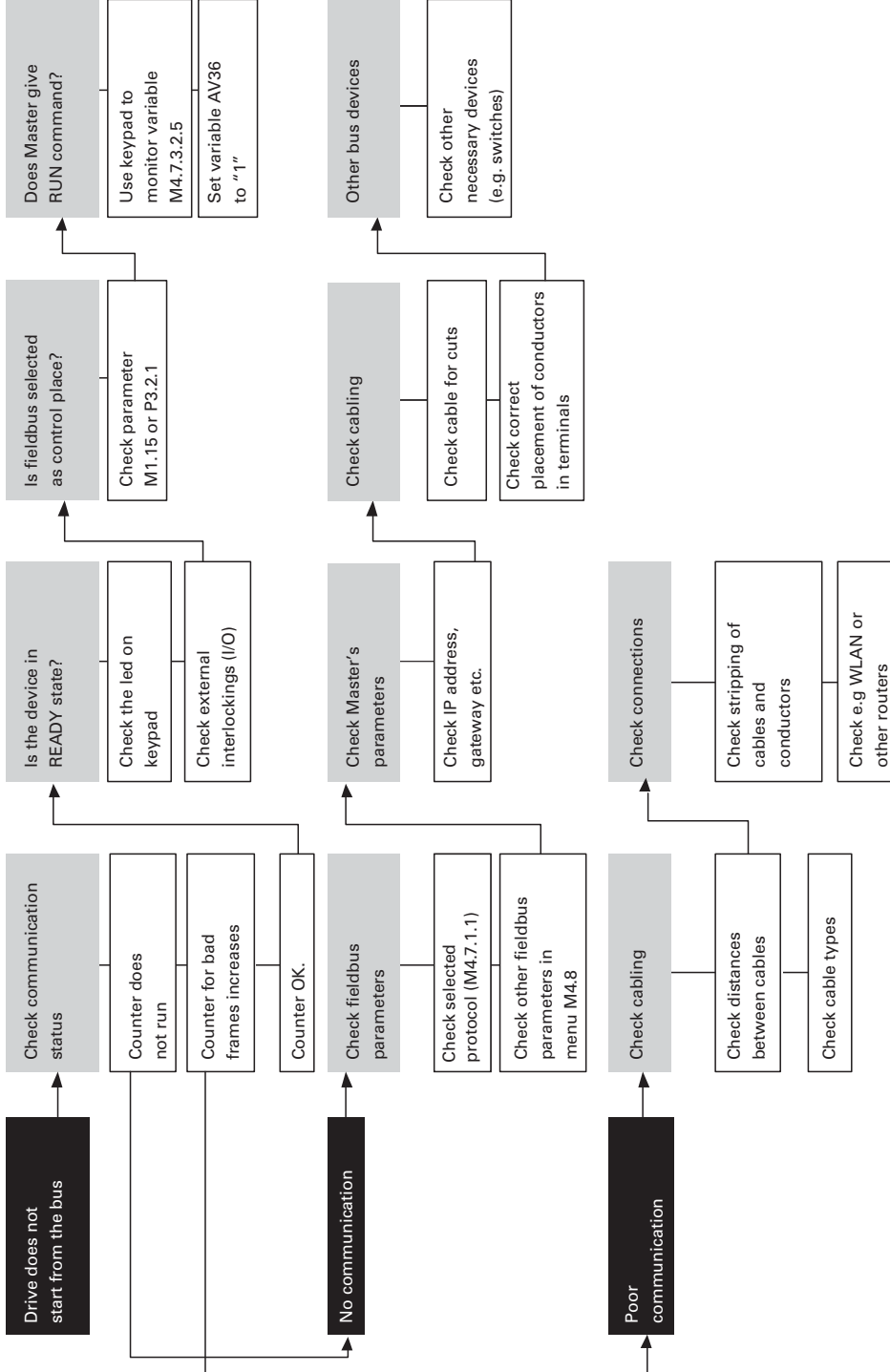

**Annex—Modbus**

***Process Data IN (Master to Slave)***

Use of Process Data In variables depends on the used application. The configuration of the data is free.

***Process Data OUT (Slave to Master)***

Use of Process Data Out variables depends on the used application.

The Fieldbus Master can read the frequency converter's actual values using process data variables. Control applications use process data as follows:

**Process Data OUT Variables**

<b>ID</b>	<b>Data</b>	<b>Value</b>	<b>Unit</b>	<b>Scale</b>
2104	Process data OUT 1	Output Frequency	Hz	0,01 Hz
2105	Process data OUT 2	Motor Speed	rpm	1 rpm
2106	Process data OUT 3	Motor Current	A	0,1 A
2107	Process data OUT 4	Motor Torque	%	0,1 %
2108	Process data OUT 5	Motor Power	%	0,1 %
2109	Process data OUT 6	Motor Voltage	V	0,1 V
2110	Process data OUT 7	DC link voltage	V	1 V
2111	Process data OUT 8	Active Fault Code	—	—



## N2 Open System Protocol

### Metasys N2 General Information

The N2 communications protocol is used by Johnson Controls and others to connect terminal unit controllers to supervisory controllers. It is open to any manufacturer and based upon a simple ASCII protocol widely used in the process control industry.

The physical characteristics of the N2 bus are three wire RS-485 with a maximum of 100 devices over a 4,000 foot distance running at 9,600 bps. Logically, the N2 is a master-slave protocol, the supervisory controller normally being the master. Data is partitioned into common HVAC control objects, such as Analog input, Analog output, binary input and binary output. N2 messaging supports the reading, writing and overriding of these points. Additionally, there are messages defined to perform uploads and downloads of devices as well as direct memory reads and writes.

### N2 Technical Data

#### N2 Protocol

Connection	Communication
Interface	RS-485
Data transfer method	RS-485 MS/TP, half-duplex
Transfer cable	STP (Shielded Twisted Pair), type Belden or similar
Connector	2.5 mm <sup>2</sup>
Electrical isolation	Functional
Metasys N2	As described in "Metasys N2 Open System Protocol Specification"
Baud rate	9600 baud
Addresses	1 to 255

### N2 Installation

1. Open the cover of the AC drive.



### WARNING

**The relay outputs and other I/O-terminals may have a dangerous control voltage present even when H-Max is disconnected from mains.**

2. Locate the components that you will need on the AC drive to connect and run the N2 cables.

### AC Drive Components (N2)

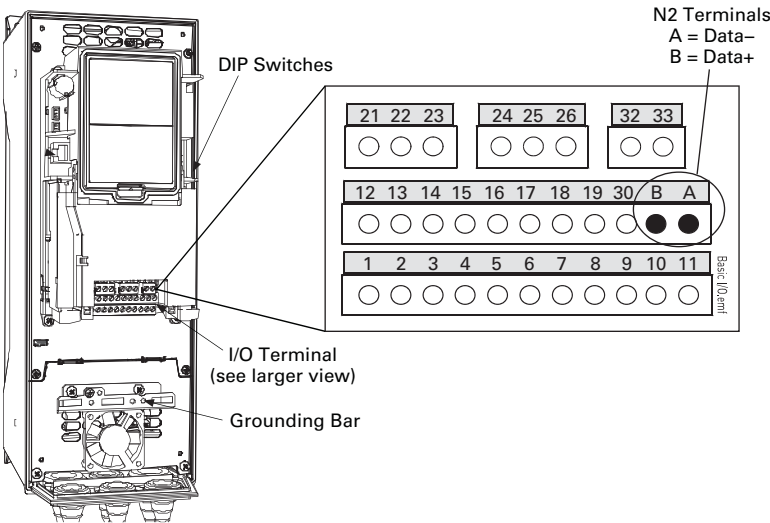

**Prepare For Use**

1. Strip about 0.59 in (15 mm) of the N2 cable (see specification on **Page 115**) and cut off the grey cable shield. Remember to do this for both bus cables (except for the last device).

Leave no more than 0.39 in (10 mm) of the cable outside the terminal block and strip the cables at about 0.20 in (5 mm) to fit in the terminals. See illustration below.

**N2 Cable Strip**

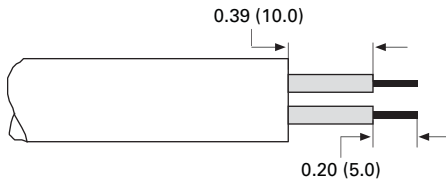

Also strip the cable now at such a distance from the terminal that you can fix it to the frame with the grounding clamp. Strip the cable at a maximum length of 0.59 in (15 mm).

**N2 Cable Strip (Aluminum Shield)**

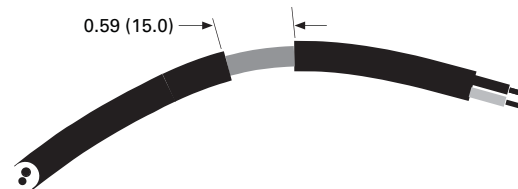

2. Then connect the cable to its appropriate terminals on H-Max AC drive standard terminal block, terminals **A and B** (A = negative, B = positive). See illustration below.

**! IMPORTANT**

Do not strip the aluminum cable shield!

**H-Max AC Drive Terminals (N2 Protocol)**

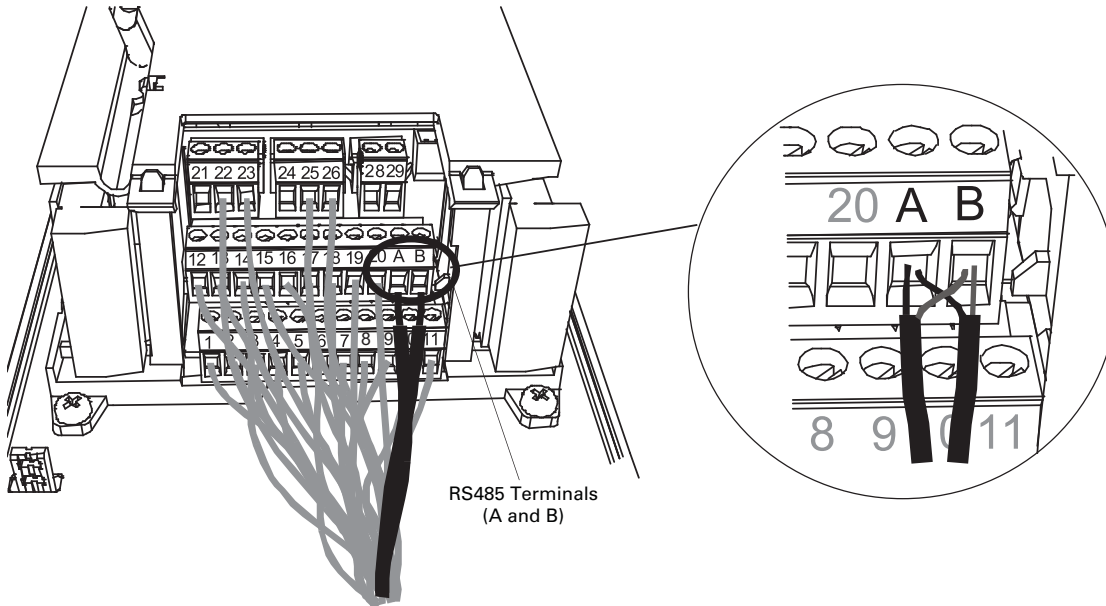

- 3. Using the cable clamp included in the delivery of the drive, ground the shield of the RS-485 cable to the frame of the AC drive.

**N2 Ground**

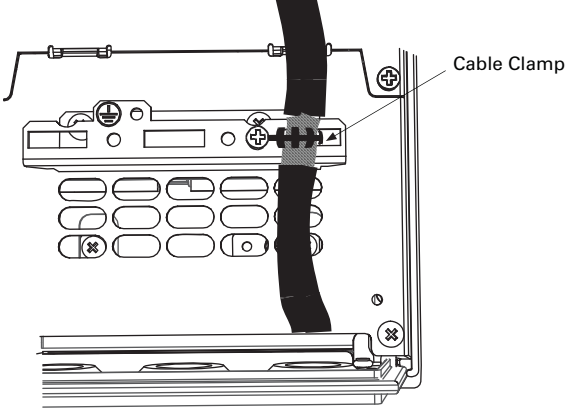

- 4. **If H-Max is the last device on the bus**, the bus termination must be set. Locate the DIP switches to the right of the control keypad of the drive and turn the switch for the RS-485 bus termination resistor to position ON. Biasing is built in the termination resistor. See also step 6 on **Page 118**.

**N2 Bus Termination Setup**

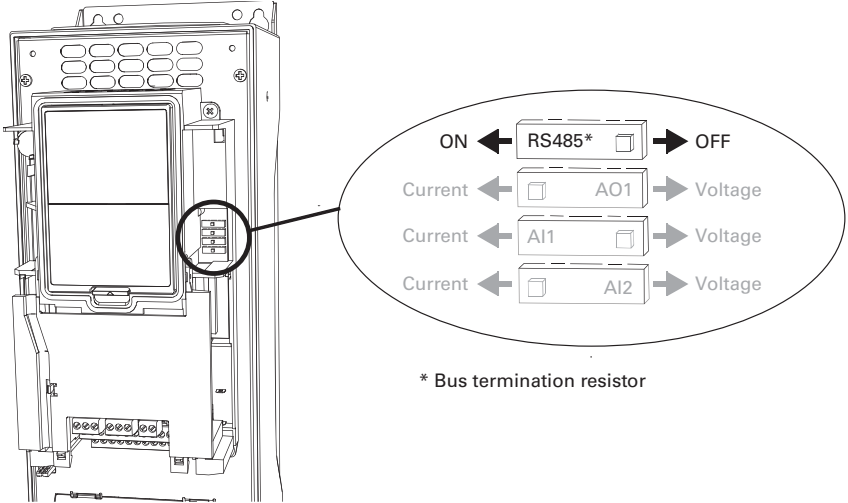

- 5. Remount the AC drive cover.

**Note:** When planning the cable runs, remember to keep the distance between the fieldbus cable and the motor cable at a **minimum of 11.81 in (30 cm)**.

- The bus termination must be set for the first and last device of the fieldbus line. See illustration below. See also step 4 on **Page 117**. We recommend that the first device on the bus and, thus, terminated was the Master device.

**N2 Bus Termination**

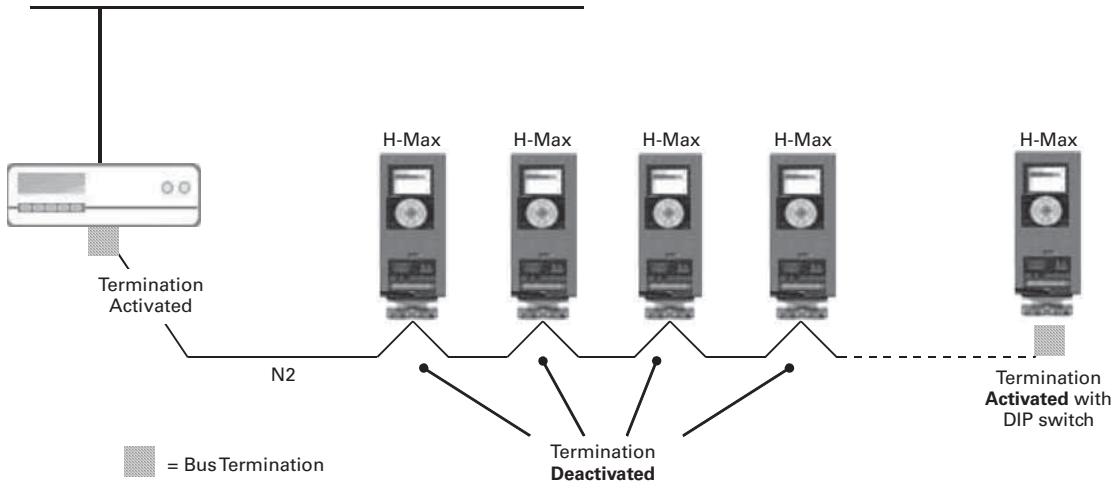

## N2 Programming

The navigation path to the fieldbus parameters may differ from application to application. The exemplary paths below apply to the H-Max HVAC drive.

1. First ensure that the right fieldbus protocol is selected.

**Navigate:**

Main Menu > I/O and Hardware > RS-485 > Common settings > Protocol > Edit > (Choose protocol)

2. Select “*Fieldbus control*” as the *Remote Control Place*.

**Navigate:**

Main Menu > Parameters > Basic Parameters > START SRC AUTO

3. Choose source of reference.

**Navigate:**

Main Menu > Parameters > Basic Parameters > Speed Setup Auto (fieldbus)

4. Set fieldbus parameters.

**Navigate:**

Main Menu > I/O and Hardware > RS-485 > N2 Settings

### N2 Parameters and Monitoring Values (M4.7.3)

#### Parameters

Code	Parameter	Min.	Max.	Unit	Default	ID	Description
<b>Parameters Related to N2</b>							
P4.7.3.1.1	Slave address	1	255	—	1	—	Unique slave device address
P4.7.3.1.2	Communication time-out	0	255	s	10	—	<b>0</b> = Not used

#### Monitoring Values

Code	Parameter	Min.	Max.	Unit	Default	ID	Description
<b>Monitoring Values Related to N2</b>							
P4.7.3.2.1	Fieldbus protocol status	1	3	—	1	—	<b>0</b> = Init <b>1</b> = Stopped <b>2</b> = Operational <b>3</b> = Faulted
P4.7.3.2.2	Communication status	0.0	99.999	—	0.0	—	<b>0–99</b> = Number of messages with errors <b>0–999</b> = Number of messages without communication errors
P4.7.3.2.3	Invalid data	0	—	—	—	—	See <b>Page 120</b>
P4.7.3.2.4	Invalid commands	0	—	—	—	—	See <b>Page 120</b>
P4.7.3.2.5	Command not accepted	0	—	—	—	—	See <b>Page 120</b>
P4.7.3.2.6	Control word	—	—	hex	—	—	See <b>Page 120</b>
P4.7.3.2.7	Status word	—	—	hex	—	—	See <b>Page 120</b>

## N2 Parameter Descriptions

### N2 Parameters

#### P4.7.3.1.1 Slave Address

Each slave must have a unique address (from 1 to 255) so that it can be addressed independently from other nodes.

#### P4.7.3.1.2 Communication Time-Out

N2 board initiates a communication error for a time defined with this parameter. "0" means that no fault is generated.

### N2 Monitoring Values

#### P4.7.3.2.1 Fieldbus Protocol Status

*Fieldbus Protocol Status* tells the status of the protocol.

#### FB Protocol Statuses

Protocol	Status
INITIALIZING	Protocol is starting up
STOPPED	Protocol is timed out or not used
OPERATIONAL	Protocol is running
FAULTED	Major fault in protocol, requires restarting. If fault remains call 877-ETN-Care (386-2273) (8am to 5pm EST) or email: TRC@Eaton.com with a description of the problem

#### P4.7.3.2.2 Communication Status

The *Communication status* shows how many error and how many good messages the frequency converter has received. The Communication status includes a common error counter that counts CRC and parity errors and a counter for good messages.

Only messages to the current slave in use are counted in the good messages.

### N2—Good Messages

Code	Description
0–999	Number of messages received without errors

### N2—Bad Frames

Code	Description
0–99	Number of messages received with errors

#### P4.7.3.2.3 Invalid Data

One of the fields contains a value that is out of the expected range.

#### P4.7.3.2.4 Invalid Commands

Command not appropriate for this field or record.

#### P4.7.3.2.5 Command Not Accepted

Due to problems with the device, the command is ignored.

#### P4.7.3.2.6 Control Word

Shows the *Control Word* received from the bus.

#### P4.7.3.2.7 Status Word

Shows the current *Status Word* that is sent to the bus.

## N2 Communications

### Features of the N2 H-Max Interface:

- Direct control of H-Max drive (e.g. Run, Stop, Direction, Speed reference, Fault reset)
- Full access to all H-Max parameters
- Monitor H-Max status (e.g. Output frequency, Output current, Fault code)

### Features of the Metasys N2 Interface

- Direct control of drive (e.g. Run, Stop, Direction, Speed reference, Fault reset)
- Full access to necessary parameters
- Monitor drive status (e.g. Output frequency, Output current, Fault code)
- In standalone operation, or should the polling stop, the overridden values are released after a specified period (about 10 minutes)

### Principal Example Diagram of Metasys N2

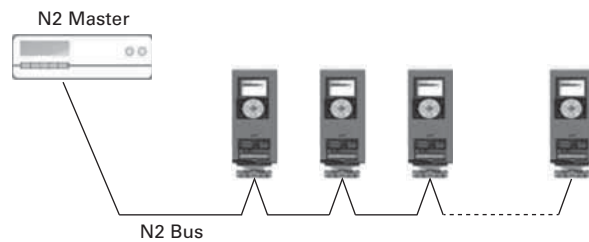

**Analog Input (AI)**

All Analog Input (AI) points have the following features:

- Support Change of State (COS) reporting based on high and low warning limits
- Support Change of State (COS) reporting based on high and low alarm limits
- Support Change of State (COS) reporting based on override status
- Always considered reliable and never out of range
- Writing of alarm and warning limit values beyond the range that can be held by the drive's internal variable will result in having that limit replaced by the "Invalid Float" value even though the message is acknowledged. The net result will be the inactivation of the alarm or warning (the same as if the original out of range value was used)
- Overriding is supported from the standpoint that the "Override Active" bit will be set and the value reported to the N2 network will be the overridden value. However, the value in the drive remains unchanged. Therefore, the N2 system should be set up to disallow overriding AI points or have an alarm condition activated when an AI point is overridden
- Overriding an AI point with a value beyond the limit allowed by the drive's internal variable will result in an "Invalid Data" error response and the override status and value will remain unchanged

**Binary Input (BI)**

All Binary Input (BI) points have the following features:

- Support Change of State (COS) reporting based on current state
- Support Change of State (COS) reporting based on alarm condition
- Support Change of State (COS) reporting based on override status
- Always considered reliable

Overriding is supported from the standpoint that the "Override Active" bit will be set and the value reported to the N2 network will be the overridden value. However, the value in the drive remains unchanged. Therefore, the N2 system should be set up to disallow overriding BI points or have an alarm condition activated when a BI point is overridden.

**Analog Output (AO)**

All Analog Output (AO) points have the following features:

- Support Change of State (COS) reporting based on override status
- Always considered reliable
- Overriding of the AO points is the method used to change a value. Overriding an AO point with a value beyond the limit allowed by the drive's internal variable will result in an "Invalid Data" error response and the override status and value will remain unchanged. If the overridden value is beyond the drive's parameter limit but within the range that will fit in the variable, an acknowledge response is given and the value will be internally clamped to its limit
- An AO point override copies the override value to the corresponding drive parameter. This is the same as changing the value on the keypad. The value is non-volatile and will remain in effect when the drive is turned off and back on. It also remains at this value when the N2 network "releases" the point. The N2 system always reads the current parameter value

**Note:** On some N2 systems, the system will not poll the AO point when it is being overridden. In this case, the N2 system will not notice a change in value if the change is made with the keypad. To avoid this, set the point up as a "local control" type and release it once it has been overridden. In this way, the N2 system will monitor the value when not being overridden.

**Binary Output (BO)**

All Binary Output (BO) points have the following features:

- Support Change of State (COS) reporting based on override status
- Always considered reliable
- Overriding BO points control the drive. These points are input commands to the drive. When released, the drive's internal value remains at its last overridden value.

**Internal Integer (ADI)**

All Internal Integer (ADI) points have the following features:

- Do not support Change of State (COS) reporting
- Can be overridden and the "Override Active" bit will be set. However, the Internal value is unchanged (Read Only)

## N2 Point Map

### Analog Inputs (AI)

#### Analog Inputs (AI)

NPT	NPA	Description	Units	Note
AI	1	Speed Setpoint	Hz	2 decimals
AI	2	Output Frequency	Hz	2 decimals
AI	3	Motor Speed	Rpm	0 decimals
AI	4	Load (power)	%	1 decimal
AI	5	Megawatt Hours	MWh	Total Counter
AI	6	Motor Current	A	2 decimals
AI	7	Bus Voltage	V	0 decimals
AI	8	Motor Volts	V	1 decimal
AI	9	Heatsink Temperature	° C	0 decimals
AI	10	Motor Torque	%	1 decimal
AI	11	Operating Days (trip)	Day	0 decimals
AI	12	Operating Hours (trip)	Hour	0 decimals
AI	13	Kilowatt Hours (trip)	kWh	Trip Counter
AI	14	Torque Reference	%	1 decimal
AI	15	Motor Temperature Rise	%	1 decimal
AI	16	FBProcessDataOut1 <sup>1</sup>	-32768 to +32767	0 decimals
AI	17	FBProcessDataOut2 <sup>1</sup>	-32768 to +32767	0 decimals
AI	18	FBProcessDataOut3 <sup>1</sup>	-32768 to +32767	0 decimals
AI	19	FBProcessDataOut4 <sup>1</sup>	-32768 to +32767	0 decimals
AI	20	FBProcessDataOut5 <sup>1</sup>	-32768 to +32767	0 decimals
AI	21	FBProcessDataOut6 <sup>1</sup>	-32768 to +32767	0 decimals
AI	22	FBProcessDataOut7 <sup>1</sup>	-32768 to +32767	0 decimals
AI	23	FBProcessDataOut8 <sup>1</sup>	-32768 to +32767	0 decimals

**Note**

<sup>1</sup> These analog inputs are application specific.

### Binary Inputs (BI)

#### Binary Inputs (BI)

NPT	NPA	Description	0 =	1 =
BI	1	Ready	Not Ready	Ready
BI	2	Run	Stop	Run
BI	3	Direction	Clockwise	Counterclockwise
BI	4	Faulted	Not Faulted	Faulted
BI	5	Alarm	Not Alarm	Alarm
BI	6	Ref. Frequency reached	False	True
BI	7	Motor running zero speed	False	True
BI	8	Flux ready	Not ready	Ready



### Analog Outputs (AO)

#### Analog Outputs (AO)

NPT	NPA	Description	Units	Note
AO	1	Comms Speed	%	2 decimals
AO	2	Current Limit	A	2 decimals
AO	3	Minimum Speed	Hz	2 decimals
AO	4	Maximum Speed	Hz	2 decimals
AO	5	Accel Time	s	1 decimal
AO	6	Decel Time	s	1 decimal
AO	7	FBProcessDataN 1 <sup>1</sup>	-32768 to +32767	2 decimals
AO	8	FBProcessDataN 2 <sup>1</sup>	-32768 to +32767	2 decimals
AO	9	FBProcessDataN 3 <sup>1</sup>	-32768 to +32767	2 decimals
AO	10	FBProcessDataN 4 <sup>1</sup>	-32768 to +32767	2 decimals
AO	11	FBProcessDataN 5 <sup>1</sup>	-32768 to +32767	2 decimals
AO	12	FBProcessDataN 6 <sup>1</sup>	-32768 to +32767	2 decimals
AO	13	FBProcessDataN 7 <sup>1</sup>	-32768 to +32767	2 decimals
AO	14	FBProcessDataN 8 <sup>1</sup>	-32768 to +32767	2 decimals
AO	15	Any parameter Read/Write	—	Depends on parameter

**Note**

<sup>1</sup> These analog inputs are application specific.

### Binary Outputs (BO)

#### Binary Outputs (BO)

NPT	NPA	Description	0 =	1 =
BO	1	Comms Start/Stop	Stop	Start
BO	2	Comms Forward/Reverse	Forward	Reverse
BO	3	Reset Fault	N/A	Reset
BO	4	Stop mode information 1	—	—
BO	5	Stop mode information 2	—	—
BO	6	Force ramp to zero	—	—
BO	7	Freeze ramp	—	—
BO	8	Reference to zero	—	—
BO	9	BusCtrl	—	—
BO	10	BusRef	—	—

### Integral Integers (ADI)

#### Integral Integers (ADI)

NPT	NPA	Description	Units
ADI	1	Active Fault Code	—
ADI	2	Control Word	—
ADI	3	Status Word	—
ADI	4	Any parameter ID	—

## N2 Fault Tracing

When an unusual operating condition is detected by the AC drive control diagnostics, the drive initiates a notification visible, for example, on the keypad. The keypad will show the ordinal number of the fault, the fault code and a short fault description.

The fault can be reset with the Reset button on the control keypad or via the I/O terminal. The faults are stored in the Fault history menu which can be browsed. The different fault codes you will find in the table below. This fault table presents only the faults related to the fieldbus in use.

**Note:** When contacting distributor or factory because of a fault condition, always write down all texts and codes on the keypad display. Call 877-ETN-Care (386-2273) (8am to 5pm EST) or email: TRC@Eaton.com with a description of the problem.

## Typical Fault Conditions

### Typical Fault Conditions

Fault Condition	Possible Cause	Remedy
Termination resistor	Missing or excessive termination resistor	Install termination resistors at both ends of the fieldbus line
Cabling	<ul style="list-style-type: none"> <li>Supply or motor cables are located too close to the fieldbus cable</li> <li>Wrong type of fieldbus cable</li> <li>Too long cabling</li> </ul>	Correct cable routing
Grounding	Inadequate grounding	Ensure grounding in all points on the net
Connections	Faulty connections <ul style="list-style-type: none"> <li>Excessive stripping of cables</li> <li>Conductors in wrong terminals</li> <li>Too loose connections of conductors</li> </ul>	Check for possible loose connections
Parameter	<ul style="list-style-type: none"> <li>Faulty address</li> <li>Overlapping slave addresses</li> <li>Wrong baud rate</li> <li>Wrong control place selected</li> </ul>	Check listed parameters for accuracy

## RS-485 Bus Biasing

When none of the devices on the RS-485 bus is sending data all devices are in idle status. This being the case, the bus voltage is in indefinite state, usually near 0V due to the termination resistors. This may cause problems in character reception because the single characters in serial communication begin with start bit referring to bus status "0" with voltage of less than 200mV whereas the bus status "1" corresponds to bus voltage of more than +200mV. The RS-485 standard considers the voltage interval -200mV...+200mV as undefined state. Bus biasing is therefore needed to maintain the voltage in status "1" (above +200mV) also between the messages.

To bias the bus you will have to add a separate active termination resistor specifically designed for the RS-485 bus (such as Siemens active RS 485 terminating element [6ES7972-0DA00-0AA0]).



**Annex—N2**

***Process Data IN (Master to Slave)***

Use of Process Data In variables depends on the used application. The configuration of the data is free.

***Process Data OUT (Slave to Master)***

Use of Process Data Out variables depends on the used application.

The Fieldbus Master can read the frequency converter's actual values using process data variables. Control applications use process data as follows:

**Process Data OUT Variables**

<b>ID</b>	<b>Data</b>	<b>Value</b>	<b>Unit</b>	<b>Scale</b>
2104	Process data OUT 1	Output Frequency	Hz	0,01 Hz
2105	Process data OUT 2	Motor Speed	rpm	1 rpm
2106	Process data OUT 3	Motor Current	A	0,1 A
2107	Process data OUT 4	Motor Torque	%	0,1 %
2108	Process data OUT 5	Motor Power	%	0,1 %
2109	Process data OUT 6	Motor Voltage	V	0,1 V
2110	Process data OUT 7	DC link voltage	V	1 V
2111	Process data OUT 8	Active Fault Code	—	—







Eaton is dedicated to ensuring that reliable, efficient and safe power is available when it's needed most. With unparalleled knowledge of electrical power management across industries, experts at Eaton deliver customized, integrated solutions to solve our customers' most critical challenges.

Our focus is on delivering the right solution for the application. But, decision makers demand more than just innovative products. They turn to Eaton for an unwavering commitment to personal support that makes customer success a top priority. For more information, **visit [www.eaton.com/electrical](http://www.eaton.com/electrical)**.

**Eaton Corporation**  
Electrical Sector  
1111 Superior Ave.  
Cleveland, OH 44114  
United States  
[Eaton.com](http://Eaton.com)

©2012 Eaton Corporation  
All Rights Reserved  
Printed in USA  
Publication No. MN04008006E / Z11405  
January 2012

Eaton is a registered trademark  
of Eaton Corporation.

All other trademarks are property  
of their respective owners.