

RG-Frame (800–2500 Amperes)

2



### Contents

<i>Description</i>	<i>Page</i>
EG-Frame (15–125 Amperes) . . . . .	<b>V4-T2-145</b>
JG-Frame (63–250 Amperes) . . . . .	<b>V4-T2-159</b>
LG-Frame (250–630 Amperes) . . . . .	<b>V4-T2-177</b>
NG-Frame (320–1200 Amperes) . . . . .	<b>V4-T2-195</b>
RG-Frame (800–2500 Amperes)	
Catalog Number Selection . . . . .	<b>V4-T2-205</b>
Product Selection . . . . .	<b>V4-T2-206</b>
Accessories . . . . .	<b>V4-T2-211</b>
Technical Data and Specifications . . . . .	<b>V4-T2-212</b>
Dimensions and Weights . . . . .	<b>V4-T2-214</b>
Motor Circuit Protectors (MCP) . . . . .	<b>V4-T2-215</b>
Motor Protector Circuit Breakers (MPCB) . . . . .	<b>V4-T2-219</b>
30 mA Ground Fault (Earth Leakage) Module . . . . .	<b>V4-T2-222</b>
Current Limiting Circuit Breaker Module . . . . .	<b>V4-T2-226</b>
High Instantaneous Circuit Breaker for	
Selective Coordination . . . . .	<b>V4-T2-231</b>
Special Features and Accessories . . . . .	<b>V4-T2-234</b>
Motor Operators . . . . .	<b>V4-T2-242</b>
Plug-In Blocks . . . . .	<b>V4-T2-244</b>
Drawout Cassette . . . . .	<b>V4-T2-245</b>

### RG-Frame (800–2500 Amperes)

#### Product Description

- Eaton’s RG-Frame circuit breakers are available as frame (which includes trip unit), rating plug and terminals
- All R-Frame circuit breakers are suitable for reverse feed use

## Catalog Number Selection

This information is presented only as an aid to understanding catalog numbers. It is not to be used to build catalog numbers for circuit breakers or trip units.

70 kA at 415 Vac and 65 kA at 480 Vac

### RG Circuit Breaker With 310+ Electronic Trip Unit

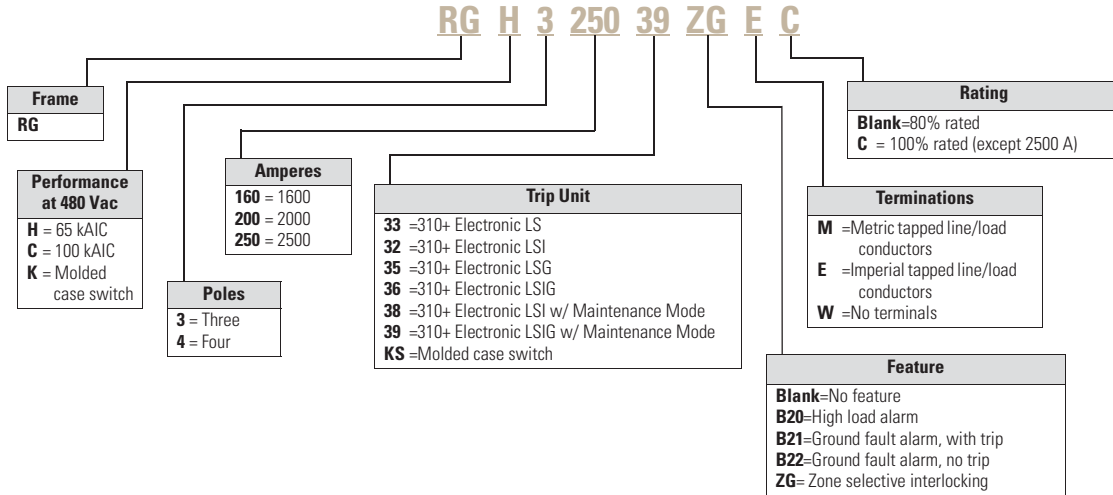

### RG 310+ Electronic Trip Unit

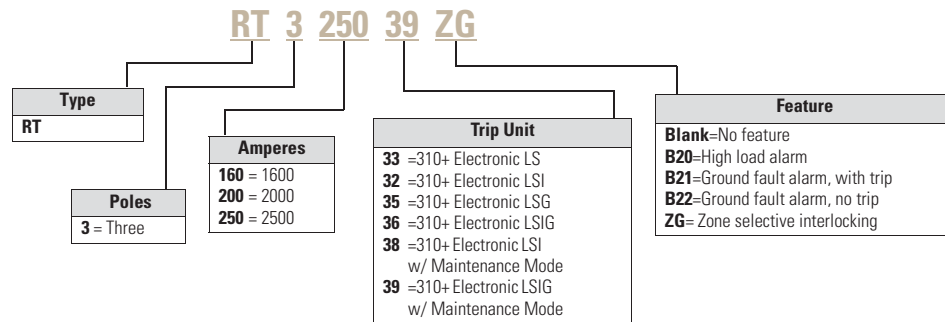

### RG Circuit Breaker with OPTIM 610 and 910 Electronic Trip Unit

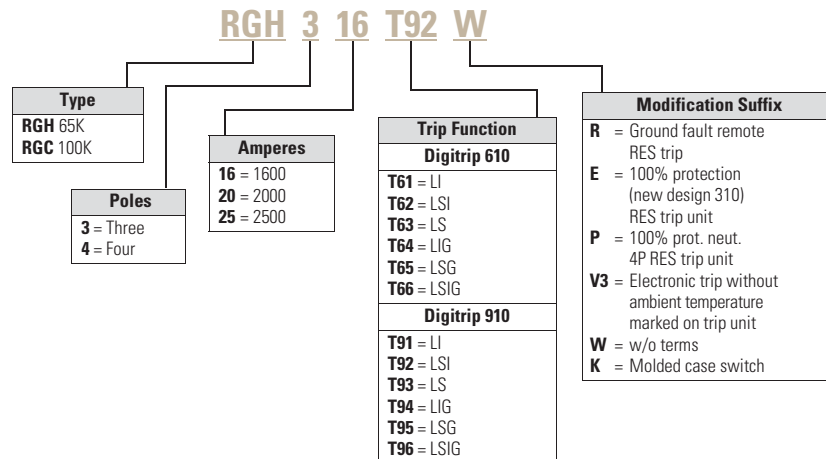

## Product Selection

2

**70 kA at 415 Vac and 65 kA at 480 Vac****Type RGH with Digitrip 310+ High Interrupting Capacity— $U_e$  Maximum 690 Vac, 70 kA  $I_{cu}$  at 415 Vac**See 310+ adjustability specifications on **Page V4-T2-213**.

Maximum Continuous Ampere Rating at 40 °C ①	Number of Poles	Circuit Breaker Frame Including Digitrip RMS 310+ Electronic Trip Unit with Adjustable Rating Plugs—Catalog Number ②						Neutral CT for LSG and LSIG ④
		LS	LSI	LSG ③	LSIG ③	ALSI	ALSIG	
1600 ①	3	RGH316033E	RGH316032E	RGH316035E	RGH316036E	RGH316038E	RGH316039E	RGFCT160A
2000	3	RGH320033E	RGH320032E	RGH320035E	RGH320036E	RGH320038E	RGH320039E	RGFCT200A
2500	3	RGH325033E	RGH325032E	RGH325035E	RGH325036E	RGH325038E	RGH325039E	RGFCT250A

**100 kA at Both 415 Vac and 480 Vac****Type RGH with Digitrip 310+ High Interrupting Capacity— $U_e$  Maximum 690 Vac, 70 kA  $I_{cu}$  at 415 Vac**See 310+ adjustability specifications on **Page V4-T2-213**.

Maximum Continuous Ampere Rating at 40 °C ①	Number of Poles	Circuit Breaker Frame Including Digitrip RMS 310+ Electronic Trip Unit with Adjustable Rating Plugs—Catalog Number ②					
		LS	LSI	LSG ③⑤	LSIG ③⑤	ALSI	ALSIG ③⑤
1600 ①	4 ⑥	RGH416033E	RGH416032E	—	—	RGH416038E	—
2000	4 ⑥	RGH420033E	RGH420032E	—	—	RGH420038E	—
2500	4 ⑥	RGH425033E	RGH425032E	—	—	RGH425038E	—

**Notes**

① For SCR application, use 2000 ampere frame.

② Order terminals separately. Mounting hardware not included.

③ Ground fault equipped trip units available with remote indicating panel. Add "R" to catalog number, for example, "RGH316035RW."

④ Required for four-wire systems if neutral protection is desired. Sold separately.

⑤ No neutral protection available on four-pole breakers with LSG or LSIG trip units.

⑥ Unprotected left pole neutral. Add "P" to catalog number for 100% protected left pole neutral, add "E" for 60% protected, for example, "RGH416033PW," "RGH416033EW."

RG MCCBs have English threading on line and load conductors. Use suffix "M" for metric threading.

**100 kA at Both 415 Vac and 480 Vac****Type RGC with Digitrip 310+ Very High Interrupting Capacity— $U_e$  Maximum 690 Vac, 100 kA  $I_{cu}$  at 415 Vac**See 310+ adjustability specifications on **Page V4-T2-213**.

Maximum Continuous Ampere Rating at 40 °C ①	Number of Poles	Circuit Breaker Frame Including Digitrip RMS 310+ Electronic Trip Unit with Adjustable Rating Plugs—Catalog Number ②						Neutral CT for LSG and LSIG ④
		LS	LSI	LSG ③	LSIG ③	ALSI	ALSIG	
1600 ①	3	RGC316033E	RGC316032E	RGC316035E	RGC316036E	RGC316038E	RGC316039E	RGFCT160A
2000	3	RGC320033E	RGC320032E	RGC320035E	RGC320036E	RGC320038E	RGC320039E	RGFCT200A
2500	3	RGC325033E	RGC325032E	RGC325035E	RGC325036E	RGC325038E	RGC325039E	RGFCT250A

**Type RGC with Digitrip 310+ Very High Interrupting Capacity— $U_e$  Maximum 690 Vac, 100 kA  $I_{cu}$  at 415 Vac, continued**See 310+ adjustability specifications on **Page V4-T2-213**.

Maximum Continuous Ampere Rating at 40 °C ①	Number of Poles	Circuit Breaker Frame Including Digitrip RMS 310+ Electronic Trip Unit with Adjustable Rating Plugs—Catalog Number ②					
		LS	LSI	LSG ③⑤	LSIG ③⑤	ALSI	ALSIG ③⑤
1600 ①	4 ⑥	RGC416033E	RGC416032E	—	—	RGC416038E	—
2000	4 ⑥	RGC420033E	RGC420032E	—	—	RGC420038E	—
2500	4 ⑥	RGC425033E	RGC425032E	—	—	RGC425038E	—

**Molded Case Switches ⑦**

Ampere Rating	Number of Poles	Catalog Number
1600	3	RGK3160KSE
2000	3	RGK3200KSE
1600	4	RGK4160KSE
2000	4	RGK4200KSE

**Notes**

- ① For SCR application, use 2000 ampere frame.
- ② Order terminals separately. Mounting hardware not included.
- ③ Ground fault equipped trip units available with remote indicating panel. Add "R" to catalog number, for example, "RGH316035RW."
- ④ Required for four-wire systems if neutral protection is desired. Sold separately.
- ⑤ No neutral protection available on four-pole breakers with LSG or LSIG trip units.
- ⑥ Unprotected left pole neutral. Add "P" to catalog number for 100% protected left pole neutral, add "E" for 60% protected, for example, "RGH416033PW," "RGH416033EW."
- ⑦ Molded case switch will trip above 17,500 amperes.

RG MCCBs have English threading on line and load conductors. Use suffix "M" for metric threading.

# 2.3

## Molded Case Circuit Breakers

### Series G

2

#### Type RG with Digitrip 610 and 910

Circuit Breaker Frame Including Digitrip RMS 610 and 910 Electronic Trip Unit with Rating Plugs  
Order as Individual Component—Catalog Number ①

Maximum Continuous Ampere Rating at 40 °C	Number of Poles	Circuit Breaker Frame Including Digitrip RMS 610 and 910 Electronic Trip Unit with Rating Plugs Order as Individual Component—Catalog Number ①						Digitrip RMS Interchangeable Rating Plug (Order as Individual Component)	Fixed Rating Plug
		LI	LS	LSI	LIG	LSG	LSIG		
Long Delay Pickup		0.5–1.0 x I <sub>n</sub>	0.5–1.0 <sub>n</sub>	0.5–1.0 x I <sub>n</sub>	0.5–1.0 x I <sub>n</sub>	0.5–1.0 x I <sub>n</sub>	0.5–1.0 x I <sub>n</sub>		
Long Delay Time		2–24 Seconds	2–24 Seconds	2–24 Seconds	2–24 Seconds	2–24 Seconds	2–24 Seconds		
Short Time Range		2–6 x I <sub>r</sub>	2–6 x I <sub>r</sub>	2–6 x I <sub>r</sub>	2–6 x I <sub>r</sub>	2–6 x I <sub>r</sub>	2–6 x I <sub>r</sub>		
Short Time Delay		—	100–500 ms	100–500 ms	—	100–500 ms	100–500 ms		
Instantaneous		2–6 x M1 and M2	—	2–6 x M1 and M2	2–6 x M1 and M2	—	2–6 x M1 and M2		
Ground Fault Pickup		—	—	—	0.25–1.0 x I <sub>n</sub> ②	0.25–1.0 x I <sub>n</sub> ②	0.25–1.0 x I <sub>n</sub> ②	Ampere Rating	
Ground Fault Delay		—	—	—	100–500 ms	100–500 ms	100–500 ms	Catalog Number	

#### Type RGH with Digitrip 610 High Interrupting Capacity—U<sub>e</sub> Max. 690 Vac, 70 kA I<sub>cu</sub> at 415 Vac

1600	3	RGH316T61WP44	RGH316T63WP44	RGH316T62WP44	RGH316T64WP44	RGH316T65WP44	RGH316T66WP44	800	RP6R16A080
								1000	RP6R16A100
								1200	RP6R16A120
								1250	RP6R16A125
								1600	RP6R16A160
Includes 1600 A rating plug									
2000	3	RGH320T61WP49	RGH320T63WP49	RGH320T62WP49	RGH320T64WP49	RGH320T65WP49	RGH320T66WP49	1000	RP6R20A100
								1200	RP6R20A120
								1250	RP6R20A125
								1600	RP6R20A160
								2000	RP6R20A200
Includes 2000 A rating plug									
2500	3	RGH325T61WP53	RGH325T63WP53	RGH325T62WP53	RGH325T64WP53	RGH325T65WP53	RGH325T66WP53	1600	RP6R25A160
								2000	RP6R25A200
								2500	RP6R25A250

#### Type RGC with Digitrip 610 Very High Interrupting Capacity—U<sub>e</sub> Max. 690 Vac, 100 kA I<sub>cu</sub> at 415 Vac

1600	3	RGC316T61WP44	RGC316T63WP44	RGC316T62WP44	RGC316T64WP44	RGC316T65WP44	RGC316T66WP44	800	RP6R16A080
								1000	RP6R16A100
								1200	RP6R16A120
								1250	RP6R16A125
								1600	RP6R16A160
Includes 1600 A rating plug									
2000	3	RGC320T61WP49	RGC320T63WP49	RGC320T62WP49	RGC320T64WP49	RGC320T65WP49	RGC320T66WP49	1000	RP6R20A100
								1200	RP6R20A120
								1250	RP6R20A125
								1600	RP6R20A160
								2000	RP6R20A200
Includes 2000 A rating plug									
2500	3	RGC325T61WP53	RGC325T63WP53	RGC325T62WP53	RGC325T64WP53	RGC325T65WP53	RGC325T66WP53	1600	RP6R25A160
								2000	RP6R25A200
								2500	RP6R25A250

#### Notes

① Order terminals separately. Mounting hardware not included.

② Not to exceed 1200 ampere ground fault pickup.

RG MCCBs have metric threading on line and load conductors. Use RD MCCBs if imperial threading is required.

Type RG with Digitrip 610 and 910, continued

		Circuit Breaker Frame Including Digitrip RMS 610 and 910 Electronic Trip Unit with Rating Plugs Order as Individual Component—Catalog Number ①						Digitrip RMS Interchangeable Rating Plug (Order as Individual Component)		
Maximum Continuous Ampere Rating at 40 °C	Number of Poles	L – Adjustable Long Delay Pickup ( $I_L$ ) with Adjustable Long Delay Time S – Adjustable Short Delay Pickup with Adjustable Short Delay Time ( $I^2t$ or Flat Response) I – Adjustable Instantaneous Pickup G – Adjustable Ground Fault Pickup with Adjustable Ground Fault Time Delay ( $I^2t$ or Flat Response)						Fixed Rating Plug	Ampere Rating	Catalog Number
		LI	LS	LSI	LIG	LSG	LSIG			
Long Delay Pickup		0.5–1.0 x $I_n$	0.5–1.0 $_n$	0.5–1.0 x $I_n$	0.5–1.0 x $I_n$	0.5–1.0 x $I_n$	0.5–1.0 x $I_n$			
Long Delay Time		2–24 Seconds	2–24 Seconds	2–24 Seconds	2–24 Seconds	2–24 Seconds	2–24 Seconds			
Short Time Range		2–6 x $I_r$	2–6 x $I_r$	2–6 x $I_r$	2–6 x $I_r$	2–6 x $I_r$	2–6 x $I_r$			
Short Time Delay		—	100–500 ms	100–500 ms	—	100–500 ms	100–500 ms			
Instantaneous		2–6 x M1 and M2	—	2–6 x M1 and M2	2–6 x M1 and M2	—	2–6 x M1 and M2			
Ground Fault Pickup		—	—	—	0.25–1.0 x $I_n$ ②	0.25–1.0 x $I_n$ ②	0.25–1.0 x $I_n$ ②			
Ground Fault Delay		—	—	—	100–500 ms	100–500 ms	100–500 ms			
<b>Type RGH with Digitrip 910 High Interrupting Capacity—<math>U_e</math> Max. 690 Vac, 70 kA <math>I_{cu}</math> at 415 Vac</b>										
1600	3	RGH316T91WP44	RGH316T93WP44	RGH316T92WP44	RGH316T94WP44	RGH316T95WP44	RGH316T96WP44	800	RP6R16A080	
								1000	RP6R16A100	
								1200	RP6R16A120	
								1250	RP6R16A125	
		Includes 1600 A rating plug						1600	RP6R16A160	
2000	3	RGH320T91WP49	RGH320T93WP49	RGH320T92WP49	RGH320T94WP49	RGH320T95WP49	RGH320T96WP49	1000	RP6R20A100	
								1200	RP6R20A120	
								1250	RP6R20A125	
								1600	RP6R20A160	
		Includes 2000 A rating plug						2000	RP6R20A200	
2500	3	RGH325T91WP53	RGH325T93WP53	RGH325T92WP53	RGH325T94WP53	RGH325T95WP53	RGH325T96WP53	1600	RP6R25A160	
								2000	RP6R25A200	
								2500	RP6R25A250	
		Includes 2500 A rating plug								
<b>Type RGC with Digitrip 910 Very High Interrupting Capacity—<math>U_e</math> Max. 690 Vac, 100 kA <math>I_{cu}</math> at 415 Vac</b>										
1600	3	RGC316T91WP44	RGC316T93WP44	RGC316T92WP44	RGC316T94WP44	RGC316T95WP44	RGC316T96WP44	800	RP6R16A080	
								1000	RP6R16A100	
								1200	RP6R16A120	
								1250	RP6R16A125	
		Includes 1600 A rating plug						1600	RP6R16A160	
2000	3	RGC320T91WP49	RGC320T93WP49	RGC320T92WP49	RGC320T94WP49	RGC320T95WP49	RGC320T96WP49	1000	RP6R20A100	
								1200	RP6R20A120	
								1250	RP6R20A125	
								1600	RP6R20A160	
		Includes 2000 A rating plug						2000	RP6R20A200	
2500	3	RGC325T91WP53	RGC325T93WP53	RGC325T92WP53	RGC325T94WP53	RGC325T95WP53	RGC325T96WP53	1600	RP6R25A160	
								2000	RP6R25A200	
								2500	RP6R25A250	
		Includes 2500 A rating plug								

Notes

① Order terminals separately. Mounting hardware not included.

② Not to exceed 1200 ampere ground fault pickup.

RG MCCBs have metric threading on line and load conductors. Use RD MCCBs if imperial threading is required.

### Accessories Selection Guide and Ordering Information

#### Line and Load Terminals

R-Frame circuit breakers use Cu/Al terminals as standard and copper only terminals as an option. Specify if factory installation is required. Must have terminals for 100% rated and or freeze testing requirements.

#### Line and Load Terminals

Maximum Breaker Amperes	Terminal Body Material	Wire Type	Hardware	AWG/kcmil Wire Range/ Number of Conductors	Metric Wire Range mm <sup>2</sup>	Catalog Number
<b>Wire Terminals</b>						
1600	Aluminum	Cu/Al	Metric	500–1000 (4)	300–500	<b>TA1600RDM</b> ①
1600	Copper	Cu	Metric	1–600 (4)	50–300	<b>T1600RDM</b> ①
2000	Aluminum	Cu/Al	Metric	2–600 (6)	35–300	<b>TA2000RDM</b> ②
<b>Rear Connectors</b>						
2000	Copper	—	Metric	—	—	<b>B2016RDM</b> ①
2000	Copper	—	Metric	—	—	<b>B2016RDLM</b> ①
2500	Copper	—	Metric	—	—	<b>B2500RDM</b> ①

#### RG Rear Connector Exploded View

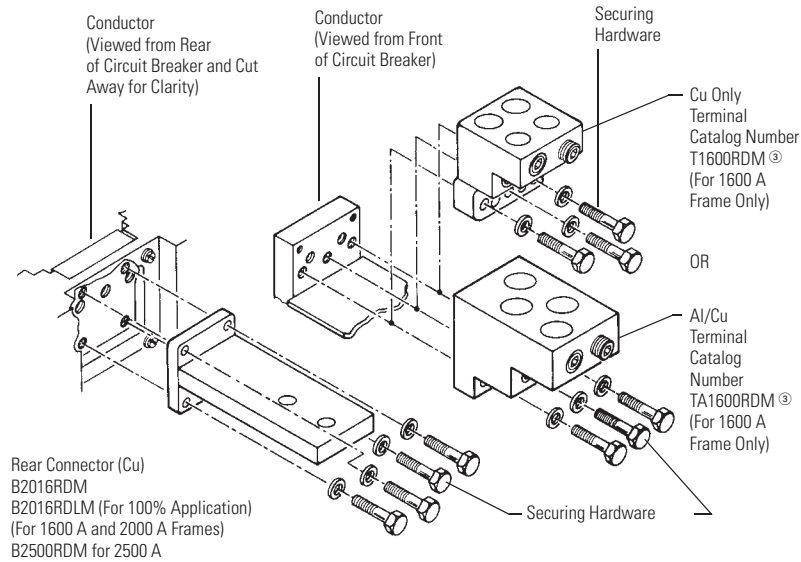

#### TA2000RD Wire Terminal

**Note:** Order one TA2000RDM kit per three poles. Catalog number includes bus connection, terminals and hardware for either line side or load side of three-pole breaker.

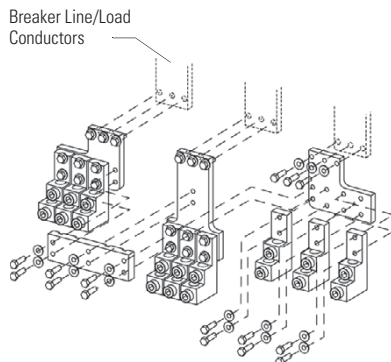

#### Base Mounting Hardware

Supplied by customer.

#### Handle Extension

Included with breaker. Additional handle extensions are available.

#### Handle Extension

Description	Catalog Number
Single handle extension	<b>HEX6</b>

#### Wire Seal

The wire seal can be used to secure the cover on the trip unit to prevent adjustments after settings are confirmed.

#### Wire Seal

Description	Catalog Number
Wire seal	<b>5108A03H01</b>

#### Notes

- ① Order one per pole—single terminals individually packed.
- ② Order one TA2000RD kit per three poles. Catalog number includes bus connection, terminals and hardware for either line side or load side of three-pole breaker.
- ③ For use with 2500 A Frame. Do not order separately unless for replacement purposes. Included in breaker carton when 2500 A frame is ordered.

RG MCCBs have metric threading on line and load conductors. Use RD MCCBs if imperial threading is required.

## Accessories

### Allowable Accessory Combinations

Different combinations of accessories can be supplied, depending on the types of accessories and the number of poles in the circuit breaker.

### RG-Frame Accessories

Description	Reference Page	Three-Pole			Four-Pole			
		Left	Center	Right	Left	Center	Right	Neutral
<b>Internal Accessories (Only One Internal Accessory Per Pole)</b>								
Alarm lockout (Make/Break)	V4-T2-239	—	—	■	—	—	■	—
Auxiliary switch (1A, 1B)	V4-T2-239	—	—	■	—	—	■	—
Auxiliary switch (2A, 2B)	V4-T2-239	—	—	■	—	—	■	—
Auxiliary switch and alarm switch combination	V4-T2-239	—	—	■	—	—	■	—
Shunt trip—standard	V4-T2-239	—	—	●	—	—	●	—
Undervoltage release mechanism	V4-T2-240	—	—	●	—	—	●	—
<b>External Accessories</b>								
Base mounting hardware	V4-T2-210	●	●	●	●	●	●	●
Padlockable handle lock hasp	V4-T2-237	□	—	□	□	—	□	—
Key interlock kit	V4-T2-237	□	—	□	□	—	□	—
Electrical operator	V4-T2-237	●	●	●	●	●	●	●
Handle mechanisms	V4-T2-522	●	●	●	●	●	●	●
Handle extension	V4-T2-210	●	●	●	●	●	●	●
Digitrip 310+ test kit	V4-T2-236	●	●	●	●	●	●	●
<b>Modifications (Refer to Eaton)</b>								
Moisture fungus treatment	V4-T2-235	●	●	●	●	●	●	●
Freeze-tested circuit breakers	—	●	●	●	●	●	●	●
Marine/naval application, UL 489 Supplement SA and SB	①	●	●	●	●	●	●	●

#### Legend

- Applicable in indicated pole position
- May be mounted on left or right pole—not both
- Accessory available/modification available

### 310+ Electronic Trip Unit Accessories

Description	Catalog Number
Electronic portable test kit	MTST230V
Trip unit tamper protection wire seal	5108A03H01
External neutral sensor (2500 A) ②	RGFCT250A
External neutral sensor (2000 A) ②	RGFCT200A
External neutral sensor (1600 A) ②	RGFCT160A
Breaker-mount cause-of-trip indication ③	—
Breaker-mount ammeter module	DIGIVIEW
Remote-mount ammeter module	DIGIVIEWR06

#### Notes

- ① Contact Eaton.
- ② Required for four-wire systems if neutral protection is desired. Sold separately.
- ③ Cause-of-trip indication LEDs integrated in RG 310+ trip units.



## Technical Data and Specifications

2

### UL 489/CSA Interrupting Capacity Ratings <sup>①</sup>

Circuit Breaker Type	Number of Poles	Interrupting Capacity (kA Symmetrical Amperes)			
		Volts AC (50/60 Hz)			
		240	277	480	600
RGH	3, 4	125	—	65	50
RGC	3, 4	200	—	100	65

### IEC 947-2 Interrupting Capacity Ratings <sup>①</sup>

Circuit Breaker Type	Number of Poles	Interrupting Capacity (kA Symmetrical Amperes)		
		Volts AC (50/60 Hz)		
		240	415	690
RGH	3, 4			
$I_{cu}$		135	70	25
$I_{cs}$		100	50	13
RGC	3, 4			
$I_{cu}$		200	100	35
$I_{cs}$		100	50	18

### RG 310+ Specifications

Description	Specification
Trip Unit Type	Digitrip RMS 310+
<b>Breaker Type</b>	
Frame designation	RG
Frames available	1600 A, 2000 A, 2500 A
Continuous current range (A)	800–2500 A
Ground fault pickup (A)	200–1200 A
Interrupting capacities at 480 Vac (kAIC)	65, 100
100% rated	Yes
<b>Protection</b>	
Ordering options	LS, LSI, LSG, LSIG, ALSI, ALSIG
Arcflash reduction maintenance system (or maintenance mode)	Yes
Interchangeable trip unit	Yes
High load alarm (suffix B20) <sup>②</sup>	Yes
Ground fault alarm with trip (suffix B21) <sup>②</sup>	Yes
Ground fault alarm, no trip (suffix B22) <sup>②</sup>	Yes
Zone selective interlocking (suffix ZG)	LSI, LSIG, ALSI, ALSIG
Cause of trip indication	Yes
Thru-cover accessories	No

#### Notes

<sup>①</sup> Utilization Category A circuit breakers.

<sup>②</sup> B2x suffixes cannot be combined with B2x suffixes.

See **Page V4-T2-204** for trip unit specifications.

## RG 310+ Adjustability Specifications

310+ Settings		RG Frame		
		1600 A	2000 A	2500 A
$I_r$ = continuous current or long delay pickup (amperes) (All 310+)	$I_r$			
	A	800	1000	1600
	B	900	1200	1700
	C	1000	1400	1800
	D	1100	1600	2000
	E	1200	1700	2100
	F	1400	1800	2200
	G	1500	1900	2400
	H (= $I_n$ )	1600	2000	2500
$t_r$ = long delay time (seconds) (All 310+)	Position 1	2	2	2
	Position 2	4	4	4
	Position 3	7	7	7
	Position 4	10	10	10
	Position 5	12	12	12
	Position 6	15	15	15
	Position 7	20	20	20
	Position 8	24	24	24
	$I_{sd}$ ( $\times I_r$ ) = short delay pickup (All 310+)	Position 1	2x	2x
Position 2		3x	3x	2x
Position 3		4x	4x	2x
Position 4		5x	5x	3x
Position 5		6x	6x	4x
Position 6		7x	7x	5x
Position 7		8x	8x	6x
Position 8		8x	8x	6x
Position 9		9x	9x	6x
$t_{sd}$ = short delay time $I^2t$ (milliseconds) (LS, LSG)	Fixed	67 at10x	67 at10x	67 at10x
$t_{sd}$ = short delay time flat (milliseconds) (LSI, LSIG, ALSI, ALSIG) ①	Position 1	Inst	Inst	Inst
	Position 2	120	120	120
	Position 3	300	300	300
$I_g$ = ground fault pickup (amperes) (LSG, LSIG, ALSIG)	Position 1	200	200	200
	Position 2	400	400	400
	Position 3	600	600	600
	Position 4	800	800	800
	Position 5	1000	1000	1000
	Position 6	1200	1200	1200
$t_g$ = ground fault delay time (milliseconds) (LSG, LSIG, ALSIG)	Position 1	Inst	Inst	Inst
	Position 2	120	120	120
	Position 3	300	300	300
Independently Adjustable Instantaneous ( $I_i$ ) setting (ALSI, ALSIG)	Yes	2.5x, 4x, 6x, 7x, 8x, 11x	2.5x, 4x, 6x, 7x, 8x, 9x	2.5x, 4x, 6x, 7x
Maintenance Mode (remote) pickup ( $2.5 \times I_n$ ) (ALSI, ALSIG) ②	Fixed	2.5x	2.5x	2.5x

**Notes**

- ① 50 ms for ALSI and ALSIG trip units.
- ② Maintenance Mode is enabled remotely using a 24 Vdc circuit.

# 2.3

## Molded Case Circuit Breakers

### Series G

#### Dimensions and Weights

Approximate Dimensions in Inches (mm)

2

#### RG-Frame

Number of Poles	Width	Height	Depth
3	15.50 (393.7)	16.00 (406.4)	9.75 (247.7)
4	20.00 (508.0)	16.00 (406.4)	9.75 (247.7)

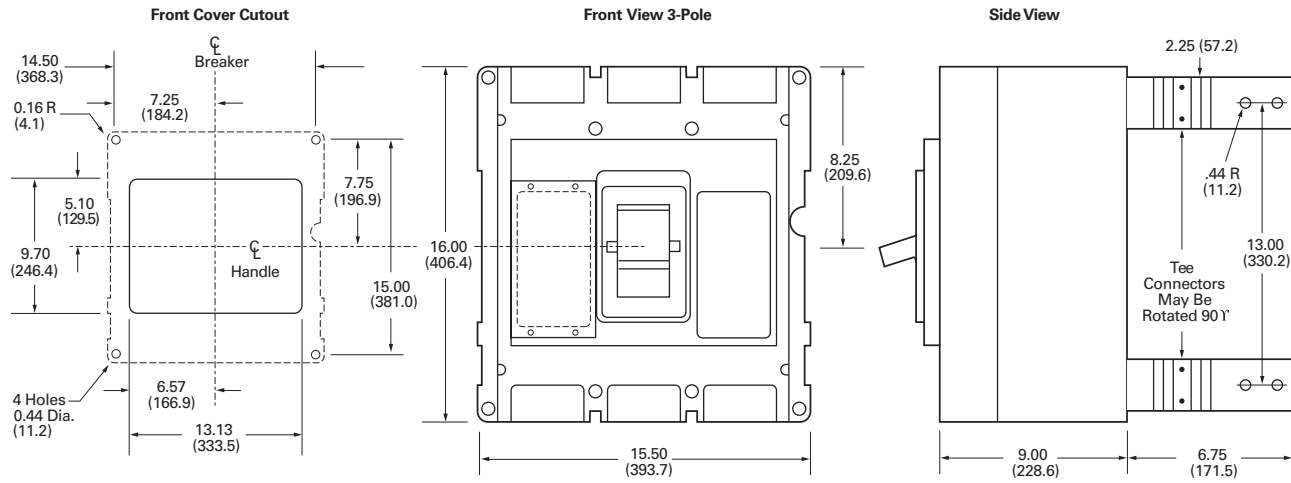

Approximate Shipping Weight in Lbs (kg)

#### RG-Frame

Breaker Type	Complete Breaker	
	Number of Poles Three-Pole	Four-Pole
<b>1600 Amperes</b>		
RGH, RGC	102 (46.3)	135 (61.2)
<b>2000 Amperes</b>		
RGH, RGC	102 (46.3)	135 (61.2)
<b>2500 Amperes</b>		
RGH, RGC	135 (61.2)	182 (82.6)