

User manual



### **DISCLAIMER OF WARRANTIES AND LIMITATION OF LIABILITY**

The information, recommendations, descriptions, and safety notations in this document are based on Eaton's experience and judgment and may not cover all contingencies. If further information is required, an Eaton sales office should be consulted. Sale of the product shown in this literature is subject to the terms and conditions outlined in appropriate Eaton selling policies or other contractual agreement between Eaton and the purchaser.

THERE ARE NO UNDERSTANDINGS, AGREEMENTS, WARRANTIES, EXPRESSED OR IMPLIED, INCLUDING WARRANTIES OF FITNESS FOR A PARTICULAR PURPOSE OR MERCHANTABILITY, OTHER THAN THOSE SPECIFICALLY SET OUT IN ANY EXISTING CONTRACT BETWEEN THE PARTIES. ANY SUCH CONTRACT STATES THE ENTIRE OBLIGATION OF EATON. THE CONTENTS OF THIS DOCUMENT SHALL NOT BECOME PART OF OR MODIFY ANY CONTRACT BETWEEN THE PARTIES.

In no event will Eaton be responsible to the purchaser or user in contract, in tort (including negligence), strict liability, or otherwise for any special, indirect, incidental, or consequential damage or loss whatsoever, including but not limited to damage or loss of use of equipment, plant or power system, cost of capital, loss of power, additional expenses in the use of existing power facilities, or claims against the purchaser or user by its customers resulting from the use of the information, recommendations, and descriptions contained herein. The information contained in this manual is subject to change without notice.

Cover Photo: Eaton PowerXL Series Drive

## **Support services**

### **Support services**

The goal of Eaton is to ensure your greatest possible satisfaction with the operation of our products. We are dedicated to providing fast, friendly, and accurate assistance. That is why we offer you so many ways to get the support you need. Whether it is by phone, fax, or email, you can access Eaton's support information 24 hours a day, seven days a week.

Our wide range of services is listed below.

You should contact your local distributor for product pricing, availability, ordering, expediting, and repairs.

### **Website**

Use the Eaton Website to find product information. You can also find information on local distributors or Eaton's sales offices.

### **Website address**

[www.eaton.com/drives](http://www.eaton.com/drives)

### **EatonCare customer support center**

Call the EatonCare Support Center if you need assistance with placing an order, stock availability or proof of shipment, expediting an existing order, emergency shipments, product price information, returns other than warranty returns, and information on local distributors or sales offices.

Voice: 877-ETN-CARE (386-2273) (8:00 a.m.–6:00 p.m. EST)  
After-Hours Emergency: 800-543-7038 (6:00 p.m.–8:00 a.m. EST)

### **Drives technical resource center**

Voice: 877-ETN-CARE (386-2273) option 2, option 6  
(8:00 a.m.–5:00 p.m. Central Time U.S. [UTC –6])  
email: [TRCDrives@Eaton.com](mailto:TRCDrives@Eaton.com)

### **For customers in Europe, contact**

Phone: +49 (0) 228 6 02-3640  
Hotline: +49 (0) 180 5 223822  
email: [AfterSalesEGBonn@Eaton.com](mailto:AfterSalesEGBonn@Eaton.com)  
[www.eaton.com/moeller/aftersales](http://www.eaton.com/moeller/aftersales)

# Table of Contents

## SAFETY

- Before commencing the installation . . . . . **vi**
- Definitions and symbols . . . . . **vii**
- Hazardous high voltage . . . . . **vii**
- Warnings and cautions . . . . . **vii**
- Motor and equipment safety . . . . . **x**

## POWERXL SERIES OVERVIEW

- How to use this manual . . . . . **1**
- Receiving and inspection . . . . . **1**
- Real time clock battery activation . . . . . **1**
- Rating label . . . . . **2**
- Carton labels (U.S. and Europe) . . . . . **2**
- Option card slots . . . . . **3**
- Option board summary . . . . . **3**
- Option card introduction . . . . . **9**

## IO1—3 X DI, 3 X DO, 1 X THERMISTOR, 24 VDC/EXT OPTION CARD

- Description . . . . . **10**
- Digital inputs . . . . . **13**
- Digital outputs . . . . . **15**
- Thermistor input . . . . . **17**
- IO1 Board parameters . . . . . **19**

## IO2—1 X AI, 2 X AO OPTION CARD

- Description . . . . . **20**
- IO2 Board parameters . . . . . **22**

## IO3—3 X RELAY DRY CONTACT (2NO + 1NO/NC) OPTION CARD

- Description . . . . . **24**
- IO3 Board parameters . . . . . **25**

## IO4—3 X PT100 RTD THERMISTOR INPUT OPTION CARD

- Description . . . . . **27**
- IO4 Board parameters . . . . . **29**

## IO5—6 X DI 120/240 VAC INPUT OPTION CARD

- Description . . . . . **31**
- IO5 Board parameters . . . . . **32**

## List of Figures

Figure 1. RTC battery connection . . . . .	<b>1</b>
Figure 2. Rating label. . . . .	<b>2</b>
Figure 3. Carton Label. . . . .	<b>2</b>
Figure 4. Drive control board layout showing option card slots . . . . .	<b>3</b>
Figure 5. Maximum loads on +24V/EXT +24V output . . . . .	<b>7</b>
Figure 6. Digital input signal conversion—positive logic. . . . .	<b>7</b>
Figure 7. Digital input signal conversion—negative logic. . . . .	<b>7</b>
Figure 8. Control cable grounding. . . . .	<b>9</b>
Figure 9. IO1 Board layout. . . . .	<b>11</b>
Figure 10. IO1 Board wire layout. . . . .	<b>12</b>
Figure 11. DG1 Digital input signal programming . . . . .	<b>13</b>
Figure 12. DH1 Digital input signal programming . . . . .	<b>14</b>
Figure 13. DG1 Digital output signal programming. . . . .	<b>15</b>
Figure 14. DH1 Digital Output Signal Programming . . . . .	<b>16</b>
Figure 15. DG1 Thermistor parameter setting. . . . .	<b>17</b>
Figure 16. DH1 Thermistor Parameter setting. . . . .	<b>18</b>
Figure 17. IO2 board layout . . . . .	<b>21</b>
Figure 18. IO2 board wire layout. . . . .	<b>21</b>
Figure 19. DG1 IO2 Parameter structure. . . . .	<b>22</b>
Figure 20. DH1 IO2 Parameter structure . . . . .	<b>22</b>
Figure 21. IO3 board layout . . . . .	<b>24</b>
Figure 22. IO3 board wire layout. . . . .	<b>25</b>
Figure 23. DG1 Parameter location . . . . .	<b>25</b>
Figure 24. DH1 IO3 Parameter structure . . . . .	<b>26</b>
Figure 25. IO4 board layout. . . . .	<b>27</b>
Figure 26. IO4 board wire layout. . . . .	<b>28</b>
Figure 27. DG1 Parameter structure . . . . .	<b>29</b>
Figure 28. DH1 IO4 Parameter structure . . . . .	<b>29</b>
Figure 29. IO5 board layout. . . . .	<b>31</b>
Figure 30. IO5 board wire layout. . . . .	<b>32</b>
Figure 31. DG1 IO5 parameter structure. . . . .	<b>32</b>
Figure 32. DH1 IO5 Parameter structure . . . . .	<b>33</b>
Figure 33. DG1 Input functions. . . . .	<b>34</b>
Figure 34. DH1 Input function. . . . .	<b>34</b>

**List of Tables**

Table 1. Common abbreviations. . . . . **1**  
Table 2. PowerXL series—PowerXL . . . . . **4**  
Table 3. Wire sizes. . . . . **8**  
Table 4. Control wiring requirements . . . . . **9**  
Table 5. I/O Card input/output . . . . . **9**  
Table 6. Digital input/output ratings. . . . . **10**  
Table 7. 24V Rating . . . . . **10**  
Table 8. IO1 Control terminals. . . . . **12**  
Table 9. Thermistor input configuration . . . . . **17**  
Table 10. IO1 Board parameters . . . . . **19**  
Table 11. IO2 Analog ratings . . . . . **20**  
Table 12. IO2 Board terminals . . . . . **21**  
Table 13. IO2 Board parameters . . . . . **22**  
Table 14. IO3 Board rating. . . . . **24**  
Table 15. IO3 Board terminals . . . . . **25**  
Table 16. IO3 Parameters . . . . . **26**  
Table 17. IO4 Thermistor ohm values. . . . . **27**  
Table 18. IO4 Board rating. . . . . **27**  
Table 19. IO4 Terminal layout. . . . . **28**  
Table 20. IO4 Parameters . . . . . **30**  
Table 21. IO5 Rating. . . . . **31**  
Table 22. IO5 Terminal layout. . . . . **32**  
Table 23. IO5 Parameters . . . . . **33**

## Safety



**Warning!**  
**Dangerous electrical voltage!**

### Before commencing the installation

- Disconnect the power supply of the device
- Ensure that devices cannot be accidentally restarted
- Verify isolation from the supply
- Earth and short circuit the device
- Cover or enclose any adjacent live components
- Only suitably qualified personnel in accordance with EN 50110-1/-2 (VDE 0105 Part 100) may work on this device/system
- Before installation and before touching the device ensure that you are free of electrostatic charge
- The functional earth (FE, PES) must be connected to the protective earth (PE) or the potential equalization. The system installer is responsible for implementing this connection
- Connecting cables and signal lines should be installed so that inductive or capacitive interference does not impair the automation functions
- Install automation devices and related operating elements in such a way that they are well protected against unintentional operation
- Suitable safety hardware and software measures should be implemented for the I/O interface so that an open circuit on the signal side does not result in undefined states in the automation devices
- Ensure a reliable electrical isolation of the extra-low voltage of the 24V supply. Only use power supply units complying with IEC 60364-4-41 (VDE 0100 Part 410) or HD384.4.41 S2
- Deviations of the input voltage from the rated value must not exceed the tolerance limits given in the specifications, otherwise this may cause malfunction and dangerous operation
- Emergency stop devices complying with IEC/EN 60204-1 must be effective in all operating modes of the automation devices. Unlatching the emergency-stop devices must not cause a restart
- Devices that are designed for mounting in housings or control cabinets must only be operated and controlled after they have been installed and with the housing closed. Desktop or portable units must only be operated and controlled in enclosed housings
- Measures should be taken to ensure the proper restart of programs interrupted after a voltage DIP or failure. This should not cause dangerous operating states even for a short time. If necessary, emergency-stop devices should be implemented
- Wherever faults in the automation system may cause injury or material damage, external measures must be implemented to ensure a safe operating state in the event of a fault or malfunction (for example, by means of separate limit switches, mechanical interlocks, and so on)
- Depending on their degree of protection, adjustable frequency drives may contain live bright metal parts, moving or rotating components, or hot surfaces during and immediately after operation
- Removal of the required covers, improper installation, or incorrect operation of motor or adjustable frequency drive may cause the failure of the device and may lead to serious injury or damage
- The applicable national accident prevention and safety regulations apply to all work carried out on live adjustable frequency drives
- The electrical installation must be carried out in accordance with the relevant regulations (for example, with regard to cable cross sections, fuses, PE)
- Transport, installation, commissioning, and maintenance work must be carried out only by qualified personnel (IEC 60364, HD 384 and national occupational safety regulations)
- Installations containing adjustable frequency drives must be provided with additional monitoring and protective devices in accordance with the applicable safety regulations. Modifications to the adjustable frequency drives using the operating software are permitted
- All covers and doors must be kept closed during operation
- To reduce hazards for people or equipment, the user must include in the machine design measures that restrict the consequences of a malfunction or failure of the drive (increased motor speed or sudden standstill of motor). These measures include:
  - Other independent devices for monitoring safety-related variables (speed, travel, end positions, and so on)
  - Electrical or non-electrical system-wide measures (electrical or mechanical interlocks)
  - Never touch live parts or cable connections of the adjustable frequency drive after it has been disconnected from the power supply. Due to the charge in the capacitors, these parts may still be live after disconnection. Fit appropriate warning signs

## PowerXL Series Option Cards

Read this manual thoroughly and make sure you understand the procedures before you attempt to install, set up, operate or carry out any maintenance work on this PowerXL Adjustable Frequency Drive.

### Definitions and symbols

---

#### WARNING

---

This symbol indicates high voltage. It calls your attention to items or operations that could be dangerous to you and other persons operating this equipment. Read the message and follow the instructions carefully.



This symbol is the "Safety Alert Symbol." It occurs with either of two signal words: CAUTION or WARNING, as described below.

---

#### WARNING

---

Indicates a potentially hazardous situation which, if not avoided, can result in serious injury or death.

---

#### CAUTION

---

Indicates a potentially hazardous situation which, if not avoided, can result in minor to moderate injury, or serious damage to the product. The situation described in the CAUTION may, if not avoided, lead to serious results. Important safety measures are described in CAUTION (as well as WARNING).

### Hazardous High Voltage

---

#### WARNING

---

Motor control equipment and electronic controllers are connected to hazardous line voltages. When servicing drives and electronic controllers, there may be exposed components with housings or protrusions at or above line potential. Extreme care should be taken to protect against shock.

- Stand on an insulating pad and make it a habit to use only one hand when checking components
- Always work with another person in case an emergency occurs
- Disconnect power before checking controllers or performing maintenance
- Be sure equipment is properly earthed
- Wear safety glasses whenever working on electronic controllers or rotating machinery

---

#### WARNING

---

The components in the drive's power section remain energized after the supply voltage has been switched off. After disconnecting the supply, wait at least five minutes before removing the cover to allow the intermediate circuit capacitors to discharge.

Pay attention to hazard warnings!



**DANGER**  
**5 MIN**

---

#### WARNING

---

Electric shock hazard—risk of injuries! Carry out wiring work only if the unit is de-energized.

---

#### WARNING

---

Do not perform any modifications on the AC drive when it is connected to mains.

### Warnings and Cautions

---

#### WARNING

---

Be sure to ground the unit following the instructions in this manual. Ungrounded units may cause electric shock and/or fire.

---

#### WARNING

---

This equipment should only be installed, adjusted, and serviced by qualified electrical maintenance personnel familiar with the construction and operation of this type of equipment and the hazards involved. Failure to observe this precaution could result in death or severe injury.

---

#### WARNING

---

Components within the drive are live when it is connected to power. Contact with this voltage is extremely dangerous and may cause death or severe injury.

---

#### WARNING

---

Line terminals (L1, L2, L3), motor terminals (U, V, W) and the DC link/brake resistor terminals (DC-, DC+/R+, R-) are live when the drive is connected to power, even if the motor is not running. Contact with this voltage is extremely dangerous and may cause death or severe injury.



---

**⚠ WARNING**

---

Even though the control I/O-terminals are isolated from line voltage, the relay outputs and other I/O-terminals may have dangerous voltage present even when the drive is disconnected from power. Contact with this voltage is extremely dangerous and may cause death or severe injury.

---

**⚠ WARNING**

---

This equipment has a large capacitive leakage current during operation, which can cause enclosure parts to be above ground potential. Proper grounding, as described in this manual, is required. Failure to observe this precaution could result in death or severe injury.

---

**⚠ WARNING**

---

Before applying power to this drive, make sure that the front and cable covers are closed and fastened to prevent exposure to potential electrical fault conditions. Failure to observe this precaution could result in death or severe injury.

---

**⚠ WARNING**

---

An upstream disconnect/protective device must be provided as required by the National Electric Code® (NEC®). Failure to follow this precaution may result in death or severe injury.

---

**⚠ WARNING**

---

This drive can cause a DC current in the protective earthing conductor. Where a residual current-operated protective (RCD) or monitoring (RCM) device is used for protection in case of direct or indirect contact, only an RCD or RCM of Type B is allowed on the supply side of this product.

---

**⚠ WARNING**

---

Carry out wiring work only after the drive has been correctly mounted and secured.

---

**⚠ WARNING**

---

Before opening the drive covers:

- Disconnect all power to the drive, including external control power that may be present
- Wait a minimum of five minutes after all the lights on the keypad are off. This allows time for the DC bus capacitors to discharge
- A hazard voltage may still remain in the DC bus capacitors even if the power has been turned off. Confirm that the capacitors have fully discharged by measuring their voltage using a multimeter set to measure the DC voltage

Failure to follow these precautions may cause death or severe injury.

---

**⚠ WARNING**

---

The opening of the branch-circuit protective device may be an indication that a fault current has been interrupted. To reduce the risk of fire or electric shock, current-carrying parts and other components of the controller should be examined and replaced if damaged. If burnout of the current element of an overload relay occurs, the complete overload relay must be replaced.

---

**⚠ WARNING**

---

Operation of this equipment requires detailed installation and operation instructions provided in the Installation/Operation manual intended for use with this product. This information is provided on the CD-ROM, floppy diskette(s) or other storage device included in the container this device was packaged in. It should be retained with this device at all times.

---

**⚠ WARNING**

---

Before servicing the drive:

- Disconnect all power to the drive, including external control power that may be present
- Place a "DO NOT TURN ON" label on the disconnect device
- Lock the disconnect device in the open position

Failure to follow these instructions will result in death or serious injury.

---

**⚠ WARNING**

---

The drive outputs (U, V, W) must not be connected to the input voltage or the utility line power as severe damage to the device may occur and there may be a risk of fire.

---

**⚠ WARNING**

---

The heat sink and/or outer enclosure may reach a high temperature.

Pay attention to hazard warnings!



Hot Surface—Risk of Burn. DO NOT TOUCH!

---

**⚠ CAUTION**

---

Any electrical or mechanical modification to this drive without prior written consent of Eaton will void all warranties and may result in a safety hazard in addition and voiding of the UL® listing.

## PowerXL Series Option Cards

---

### CAUTION

---

Install this drive on flame-resistant material such as a steel plate to reduce the risk of fire.

---

### CAUTION

---

Install this drive on a perpendicular surface that is able to support the weight of the drive and is not subject to vibration, to lessen the risk of the drive falling and being damaged and/or causing personal injury.

---

### CAUTION

---

Prevent foreign material such as wire clippings or metal shavings from entering the drive enclosure, as this may cause arcing damage and fire.

---

### CAUTION

---

Install this drive in a well-ventilated room that is not subject to temperature extremes, high humidity, or condensation, and avoid locations that are directly exposed to sunlight, or have high concentrations of dust, corrosive gas, explosive gas, inflammable gas, grinding fluid mist, etc. Improper installation may result in a fire hazard.

---

### CAUTION

---

When selecting the cable cross-section, take the voltage drop under load conditions into account. The consideration of other standards is the responsibility of the user.

The user is responsible for compliance with all international and national electrical standards in force concerning protective grounding of all equipment.

---

### CAUTION

---

The specified minimum PE conductor cross-sections in this manual must be maintained.

Touch current in this equipment exceeds 3.5 mA (AC). The minimum size of the protective earthing conductor shall comply with the requirements of EN 61800-5-1 and/or the local safety regulations.

---

### CAUTION

---

Touch currents in this frequency inverter are greater than 3.5 mA (AC). According to product standard IEC/EN 61800-5-1, an additional equipment grounding conductor of the same cross-sectional area as the original protective earthing conductor must be connected, or the cross-section of the equipment grounding conductor must be at least 10 mm<sup>2</sup> Cu. Drive requires that only copper conductor should be used.

---

### CAUTION

---

Debounced inputs may not be used in the safety circuit diagram. Residual current circuit breakers (RCD) are only to be installed between the AC power supply network and the drive.

---

### CAUTION

---

Debounced inputs may not be used in the safety circuit diagram. If you are connecting multiple motors on one drive, you must design the contactors for the individual motors according to utilization category AC-3.

Selecting the motor contactor is done according to the rated operational current of the motor to be connected.

---

### CAUTION

---

Debounced inputs may not be used in the safety circuit diagram. A changeover between the drive and the input supply must take place in a voltage-free state.

---

### CAUTION

---

Debounced inputs may not be used in the safety circuit diagram. Fire hazard!

Only use cables, protective switches, and contactors that feature the indicated permissible nominal current value.

---

### CAUTION

---

Before connecting the drive to AC mains make sure that the EMC protection class settings of the drive are appropriately made according to instructions in this manual.

- If the drive is to be used in a floating distribution network, remove screws at MOV and EMC
- Disconnect the internal EMC filter when installing the drive on an IT system (an ungrounded power system or a high-resistance-grounded [over 30 ohm] power system), otherwise the system will be connected to ground potential through the EMC filter capacitors. This may cause danger, or damage the drive
- Disconnect the internal EMC filter when installing the drive on a corner grounded TN system, otherwise the drive will be damaged

**Note:** When the internal EMC filter is disconnected, the drive might be not EMC compatible.

- Do not attempt to install or remove the MOV or EMC screws while power is applied to the drive's input terminals

## Motor and equipment safety

---

### CAUTION

---

Do not perform any megger or voltage withstand tests on any part of the drive or its components. Improper testing may result in damage.

---

### CAUTION

---

Prior to any tests or measurements of the motor or the motor cable, disconnect the motor cable at the drive output terminals (U, V, W) to avoid damaging the drive during motor or cable testing.

---

### CAUTION

---

Do not touch any components on the circuit boards. Static voltage discharge may damage the components.

---

### CAUTION

---

Before starting the motor, check that the motor is mounted properly and aligned with the driven equipment. Ensure that starting the motor will not cause personal injury or damage equipment connected to the motor.

---

### CAUTION

---

Set the maximum motor speed (frequency) in the drive according to the requirements of the motor and the equipment connected to it. Incorrect maximum frequency settings can cause motor or equipment damage and personal injury.

---

### CAUTION

---

Before reversing the motor rotation direction, ensure that this will not cause personal injury or equipment damage.

---

### CAUTION

---

Make sure that no power correction capacitors are connected to the drive output or the motor terminals to prevent drive malfunction and potential damage.

---

### CAUTION

---

Make sure that the drive output terminals (U, V, W) are not connected to the utility line power as severe damage to the drive may occur.

---

### CAUTION

---

When the control terminals of two or more drive units are connected in parallel, the auxiliary voltage for these control connections must be taken from a single source which can either be one of the units or an external supply.

---

### CAUTION

---

The drive will start up automatically after an input voltage interruption if the external run command is on.

---

### CAUTION

---

Do not control the motor with the disconnecting device (disconnecting means); instead, use the control panel start and stop keys and, or commands via the I/O board of the drive. The maximum allowed number of charging cycles of the DC capacitors (i.e. power-ups by applying power) is five in ten minutes.

---

### CAUTION

---

#### **Improper drive operation:**

- If the drive is not turned on for a long period, the performance of its electrolytic capacitors will be reduced
- If it is stopped for a prolonged period, turn the drive on at least every six months for at least 5 hours to restore the performance of the capacitors, and then check its operation. It is recommended that the drive is not connected directly to the line voltage. The voltage should be increased gradually using an adjustable AC source

#### **Failure to follow these instructions can result in injury and/or equipment damage.**

For more technical information, contact the factory or your local Eaton sales representative.

## PowerXL Series Overview

This chapter describes the purpose and contents of this manual, the receiving inspection recommendations and the PowerXL Series Open Drive catalog numbering system.

### How to use this manual

The purpose of this manual is to provide you with information necessary to install, set and customize parameters, start up, troubleshoot and maintain the Eaton PowerXL Series adjustable frequency drive (VFD). To provide for safe installation and operation of the equipment, read the safety guidelines at the beginning of this manual and follow the procedures outlined in the following chapters before connecting power to the PowerXL Series VFD. Keep this operating manual handy and distribute to all users, technicians and maintenance personnel for reference.

### Receiving and inspection

The PowerXL Series VFD has met a stringent series of factory quality requirements before shipment. It is possible that packaging or equipment damage may have occurred during shipment. After receiving your PowerXL Series VFD, please check for the following:

Check to make sure that the package includes the Instruction Leaflet, Quick Start Guide and accessory packet. The accessory packet includes:

- Rubber grommets
- Control cable grounding clamps
- Additional grounding screw

Inspect the unit to ensure it was not damaged during shipment.

Make sure that the part number indicated on the nameplate corresponds with the catalog number on your order.

If shipping damage has occurred, please contact and file a claim with the carrier involved immediately.

If the delivery does not correspond to your order, please contact your Eaton Electrical representative.

**Note:** Do not destroy the packing. The template printed on the protective cardboard can be used for marking the mounting points of the PowerXL VFD on the wall or in a cabinet.

### Real time clock battery activation

To activate the real time clock (RTC) functionality in the PowerXL Series VFD, the RTC battery (already mounted in the drive) must be connected to the control board.

Simply remove the primary drive cover, locate the RTC battery directly below the keypad, and connect the white 2-wire connector to the receptacle on the control board.

Figure 1. RTC battery connection



Table 1. Common abbreviations

Abbreviation	Definition
CT	Constant torque with high overload rating (150%)
VT	Variable torque with low overload rating (110%)
IH	High Overload (150%)
IL	Low Overload (110%)
VFD	Variable Frequency Drive

Rating label

Figure 2. Rating label

<b>EATON</b> Powering Business Worldwide			
Type: DG1-34038FB-C21C			
Style No.: 9702-3005-XX			
Article No.: 9702-3004-XX			
PowerXL™ DG1 VFD Factory ID: I			
CT/VT		Input	Output
18.5KW 22KW	U(V~)	380-440 3Ø	0~Vin 3Ø
	F(Hz)	50/60 Hz	0-400 Hz
	I (A)	42.6	38/46
25HP 30HP	U(V~)	440-500 3Ø	0~Vin 3Ø
	F(Hz)	50/60 Hz	0-400 Hz
	I (A)	42.6	34/40
Enclosure Rating		TYPE1 / IP21	
User installation manual MN040002EN			
Serial No.: XXXXXXXXXX			
E A N: 4015081721450			
NAED: 78668878928			
Field installed conductors must be copper rated at 75°C			
XXXXXX www.eaton.com Made in China			

<b>EATON</b> Powering Business Worldwide			
Type: DH1-343D3FN-N21C			
Style No.: 9712-1014-XX			
Article No.: 9712-1014-XX			
PowerXL™ DH1 VFD Factory ID: I			
VT		Input	Output
1.1KW	U(V~)	380-440 3Ø	0~Vin 3Ø
	F(Hz)	50/60 Hz	0-400 Hz
	I (A)	3.1	3.3
1.5HP	U(V~)	440-500 3Ø	0~Vin 3Ø
	F(Hz)	50/60 Hz	0-400 Hz
	I (A)	3.1	3
Enclosure Rating		TYPE1 / IP21	
User installation manual MN040002EN			
Serial No.: XXXXXXXXXX			
E A N: 4015081907069			
NAED: 78668878928			
Field installed conductors must be copper rated at 75°C			
XXXXXX www.eaton.com Made in China			

Carton labels (U.S. and Europe)

Figure 3. Carton Label

<b>EATON</b> Powering Business Worldwide			
Type: DG1-34038FB-C21C			
Style No.: 9702-3005-XX			
Article No.: 9702-3004-XX			
PowerXL™ DG1 VFD Factory ID: I			
CT/VT		Input	Output
18.5KW 22KW	U(V~)	380-440 3Ø	0~Vin 3Ø
	F(Hz)	50/60 Hz	0-400 Hz
	I (A)	42.6	38/46
25HP 30HP	U(V~)	440-500 3Ø	0~Vin 3Ø
	F(Hz)	50/60 Hz	0-400 Hz
	I (A)	42.6	34/40
Enclosure Rating		TYPE1 / IP21	
User installation manual MN040002EN			
Serial No.: XXXXXXXXXX			
E A N: 4015081721450			
NAED: 78668878928			
N.W.: XX.XX KG	G.W.: XX.XX KG		
XXXXXX	www.eaton.com	Made in China	

<b>EATON</b> Powering Business Worldwide			
Type: DH1-343D3FN-N21C			
Style No.: 9712-1014-XX			
Article No.: 9712-1014-XX			
PowerXL™ DH1 VFD Factory ID: I			
VT		Input	Output
1.1KW	U(V~)	380-440 3Ø	0~Vin 3Ø
	F(Hz)	50/60 Hz	0-400 Hz
	I (A)	3.1	3.3
1.5HP	U(V~)	440-500 3Ø	0~Vin 3Ø
	F(Hz)	50/60 Hz	0-400 Hz
	I (A)	3.1	3
Enclosure Rating		TYPE1 / IP21	
User installation manual MN040002EN			
Serial No.: XXXXXXXXXX			
E A N: 4015081907069			
NAED: 78668878928			
N.W.: XX.XX KG	G.W.: XX.XX KG		
XXXXXX	www.eaton.com	Made in China	

### Option card slots

The control board is located inside the control unit of the PowerXL Series Drive. There are two slots, labeled A and B, on the control board. The different option boards can be added to any slots. When the PowerXL Series Drive is assembled at the factory, no option boards are installed in slots A and B. If an incorrect board is plugged into either slot, the board will not work, but there is no danger to personnel or for equipment damage.

### Option board summary

There are a total of five I/O option cards available on the PowerXL that can be placed in either Slot A or B.

- IO1 = 3 DI, 3 DO, 1 thermistor, 24 Vdc/EXT
- IO2 = 1 AI, 2 AO (isolated to control board)
- IO3 = 3 Relay Dry Contact (2 NO and 1 NO/NC)
- IO4 = Qty. 3 PT100 RTD input
- IO5 = 6 DI 120/240 Vac Input

Figure 4. Drive control board layout showing option card slots

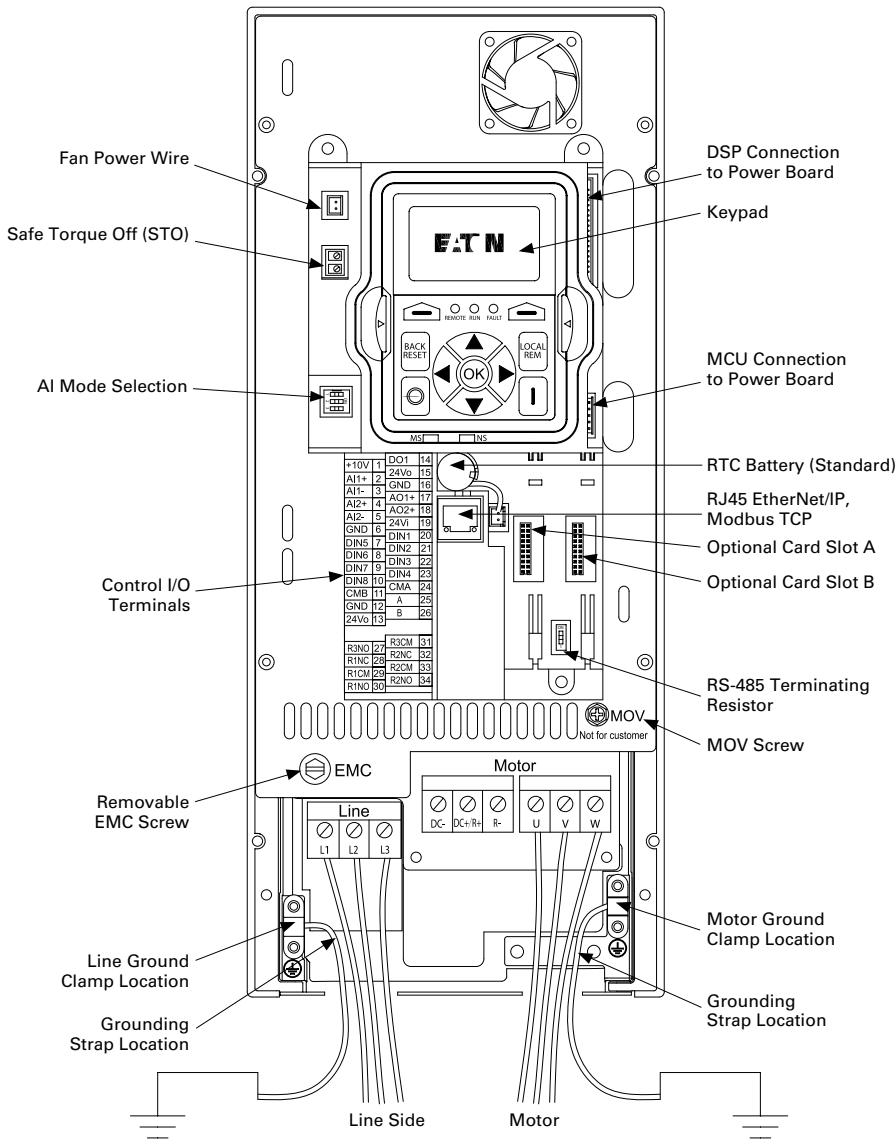

## Technical data

**Table 2. PowerXL Series**

Attribute	Description	Specification	
Input ratings	Input voltage $U_{in}$	208 V to 240 V, 380 V to 500 V, 525 V to 600 V, -15 to 10%	
	Input frequency	50 Hz to 60 Hz (variation up to 45 Hz to 66 Hz)	
	Connection to power	Once per minute or less	
	Starting delay	3 s (FR1 to FR2), 4 s (FR3), 5 s (FR4), 6 s (FR5 and FR6)	
	Short-circuit withstand rating	100 kAIC (fuses and circuit breakers)	
Output ratings	Output voltage	0 to $U_{in}$	
	Continuous output current	$I_L$ : ambient temperature maximum 40 °C, up to 60 °C with derating, overload 1.1 x $I_L$ (1 min./10 min.) $I_H$ : ambient temperature maximum 50 °C, up to 60 °C with derating, overload 1.5 x $I_H$ (1 min./10 min.)	
	Overload current	150% respectively 110% (1 min./10 min.)	
	Initial output current	200% (2 s / 20 s) based of the drives rated nameplate $I_H$ current rating.	
	Output frequency	0–400 Hz (standard)	
	Frequency resolution	0.01 Hz	
Control characteristics	Control methods	Frequency control Speed control Open-loop speed control Open-loop torque control	
	Switching frequency	230 V / 480 V Range: FR1–3: 1 kHz to 12 kHz FR4–6: 1 kHz to 10 kHz 230 V / 480 V defaults: FR1–3: 4 kHz FR4–5: 3.6 kHz FR6: 2 kHz 600 V range: FR1–6: 1 kHz to 6 kHz 600 V defaults: FR1–6: 1.5 kHz Automatic switching frequency derating in case of overload.	
	Frequency reference	Analog input: resolution 0.1% (10-bit), accuracy +1% Analog output: resolution 0.1% (10-bit), accuracy +1% Panel reference: resolution 0.01 Hz	
	Field weakening point	20 Hz to 400 Hz	
	Acceleration time	0.1 s to 3000 s	
	Deceleration time	0.1 s to 3000 s	
	Braking torque	DC brake: 30% x Motor Rated Torque ( $T_n$ ) (without brake chopper) Dynamic braking (with optional brake chopper using an external brake resistor): 100% continuous maximum rating	
	Ambient conditions	Ambient operating temperature	-10 °C (no frost) to +50 °C, up to +60 °C with derating (CT) -10 °C (no frost) to +40 °C, up to +60 °C with derating (VT)
		Storage temperature	-40 °C to +70 °C
		Relative humidity	0–95% RH, noncondensing, non-corrosive
Air quality: • Chemical vapors • Mechanical particles		Tested according to IEC 60068-2-60 Test Key: Flowing mixed gas corrosion test, Method 1 (H2S [hydrogen sulfide] and SO2 [sulfur dioxide]) Designed according to: IEC 60721-3-3, unit in operation, class 3C2 IEC 60721-3-3, unit in operation, class 3S2	

## PowerXL Series Overview

**Table 2. PowerXL Series, continued**

Attribute	Description	Specification
Ambient conditions, continued	Altitude	100% load capacity (no derating) up to 3280 ft (1000 m); 1% derating for each 328 ft (100 m) above 3280 ft (1000 m); max. 9842 ft (3000 m) (2000 m for corner grounded earth main systems) For 600 V product, maximum altitude is 2000 m regardless of main system
	Vibration: • EN 61800-5-1 • EN 60668-2-6	5–150 Hz Displacement amplitude: 1 mm (peak) at 5 Hz to 15.8 Hz (FR1–FR6) Maximum acceleration amplitude: 1g at 15.8 Hz to 150 Hz (FR1–FR6)
	Shock: • ISTA 1 A • EN 60068-2-27	Storage and shipping: maximum 15 g, 11 ms (in package)
	Overvoltage	Overvoltage Category III
	Pollution degree	Pollution Degree 2
	Enclosure class	FR0: Open Type/IP20 FR1–FR6: IP21/Type 1 Standard in entire kW/hp range IP54/Type 12 option Note: Keypad or keypad hole plug required to be mounted in drive for IP54/Type 12 rating
	Immunity	Fulfills IEC 61800-3 (2004) + A1 (2012), first and second environment
	MTBF	FR0: 150,000 hours FR1: 165,457 hours FR2: 134,833 hours FR3: 102,515 hours FR4: 121,567 hours FR5: 108,189 hours FR6: 100,000 hours
Standards	Noise	FR0: 51.7 dB FR1: 51.2 dB FR2: 58.6 dB FR3: 61.0 dB FR4: 68.0 dB FR5: 69.1 dB FR6: 73.2 dB
	Safety	UL 508C, CSA C22.2 No. 274-13 / CSA C22.2 No. 274-17 and EN 61800-5-1
	EMC	IEC/EN 61800-3 (2004) + A1 (2012) 230/480V Series: Category C2 575V Series: Category C3 The drive can be modified for IT networks and corner grounding TN system
	Electrostatic discharge	Second environment, IEC 61000-4-2, 4 kV CD or 8 kV AD, Criterion B
	Fast transient burst	Second environment, IEC 61000-4-4, 2 kV/5 kHz, Criterion B
	Dielectrical strength	Primary to secondary: 230 V: 4240 Vdc 480 V: 5100 Vdc 600 V: 5100 Vdc Primary to earth: 230 V: 2130 Vdc 480 V: 2830 Vdc 600 V: 3111 Vdc
	Approvals	CE, UL and cUL, EAC, RCM (C-Tick), RoHS (see nameplate for more detailed approvals)
	Fieldbus connections	Onboard DG1: EtherNet/IP, Modbus <sup>®</sup> TCP, Modbus RTU, BACnet Onboard DH1: Modbus TCP, BACnet/IP, Modbus RTU, BACnet



**Table 2. PowerXL Series, continued**

<b>Attribute</b>	<b>Description</b>	<b>Specification</b>
Safety/protections	Overvoltage protection	Yes
	Overvoltage trip limit	230 V drives: 456 V 480 V drives: 911 V 600 V drives: 1100 V
	Undervoltage protection	Yes
	Undervoltage trip limit	230 V drives: 211 V 480 V drives: 370 V 600 V drives: 550 V
	Earth fault protection	Yes, Default: 15% Motor FLA Min: 0% Motor FLA Max: 30% Motor FLA
	Input phase supervision	Yes
	Motor phase supervision	Yes
	Overcurrent protection	Yes
	Unit overtemperature protection	Yes
	Motor overload protection	Yes
	Motor stall protection	Yes
	Motor underload protection	Yes
	DC bus overvoltage control	Yes
	Short-circuit protection of 24 V reference voltages	Yes
	Surge protection	Yes (differential mode 2 kV; common mode 4 kV 230 V drives: 275 Vac, 10,000 A 480 V drives: 320 Vac, 8000 A 600 V drives: 385 Vac, 10,000 A
Common coated boards	Yes (prevents corrosion)	
Efficiency	Drive efficiency ratings	230 V: FR0 = DG1-323D7EB-C20C: 96.37% DG1-324D8EB-C20C: 96.38% DG1-326D6EB-C20C: 96.31% FR1 = 96.7% FR2 = 97.4% FR3 = 97.2% FR4 = 97.4% FR5 = 97.7% FR6 = 97.5% 480 V: FR0 = DG1-342D2EB-C20C: 97.23% DG1-343D3EB-C20C: 97.33% DG1-344D3EB-C20C: 97.27% DG1-345D6EB-C20C: 97.15% FR1 = 97.7% FR2 = 97.9% FR3 = 97.7% FR4 = 98.0% FR5 = 98.2% FR6 = 97.9% 600 V: FR1 = 98.1% FR2 = 98.2% FR3 = 97.7% FR4 = 98.3% FR5 = 98.6% FR6 = 98.5%

**Isolation**

The control connections are isolated from the utility potential, and shipped with the I/O ground connected directly to the frame of the PowerXL Series Drive. Digital inputs and relay outputs are isolated from the I/O ground via optical isolation. For digital input arrangements, see "Digital Input Signal Conversion." Analog input and output signals are galvanically isolated from the main control board but not independent of the other channels.

**Analog inputs (mA/V)**

The analog inputs of the I/O boards can be used as either current inputs or voltage inputs (see the detailed description

of each board). The signal type is selected with a DIP switch on the board. If either voltage or current analog input is used, you will need to define the range with the analog option cards parameters. The factory default values for the analog signal selection are given in the description of the board. For detailed information, see the description of the board of interest.

**Analog outputs (mA/V)**

Most of the expander boards with analog output can be configured for a current or voltage output with a DIP switch. Some boards only provide an analog current output. For detailed information, see the description of the board of interest.

## PowerXL Series Overview

### Power supply (+24 Vdc Out/+24 Vdc In)

The power supply can only exist on IO1 board, which includes a 24 Vdc in and a 24 Vdc out.

The 24 Vdc out is used to power up external equipment, such as encoders and auxiliary relays. Note that the total combined load on all available 24 Vdc out terminals must not exceed 250 mA. The maximum load on the 24 Vdc out per board is 150 mA.

The 24 Vdc in can be connected to an external +24V power supply to power up the base board and expander boards. If an external power supply is connected to the 24 Vdc in, the base board and expander boards remain live even if the utility power is lost.

Requirements for an external 24V power supply:

- Output voltage +24 Vdc  $\pm 10\%$ , max. ripple voltage 100 mV rms
- Maximum current 1A
- 1A external fuse (no internal short-circuit protection is provided on the base board for the external 24V input)

**Figure 5. Maximum loads on +24V/EXT +24V output**

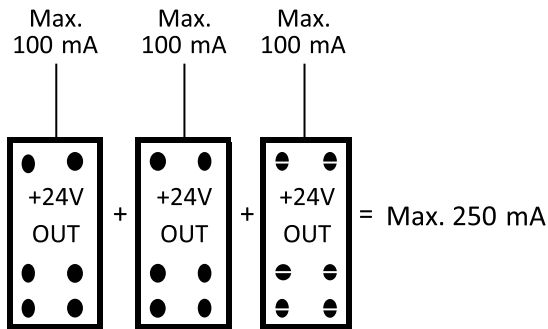

### Digital input signal conversion

The active signal level depends on which potential the common input is connected to. The alternatives are +24V or Ground (0V).

The 24-volt control voltage and the ground for the digital inputs and the common input can be from either the internal +24V supply or an external source.

Two typical input signal connection examples are shown below, which can be done with external +24V or internal +24V.

**Figure 6. Digital input signal conversion—positive logic**

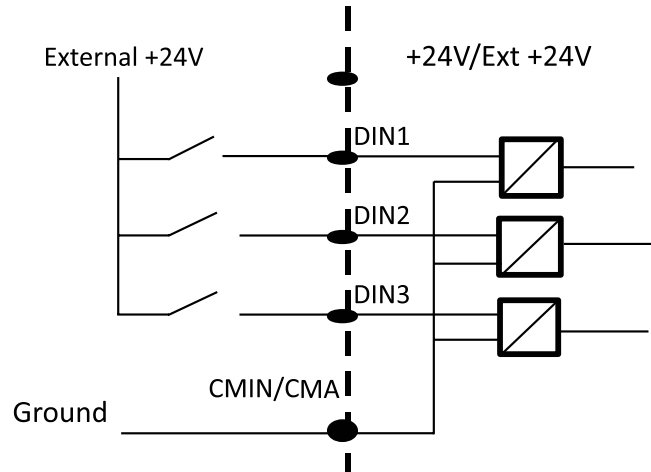

**Figure 7. Digital input signal conversion—negative logic**

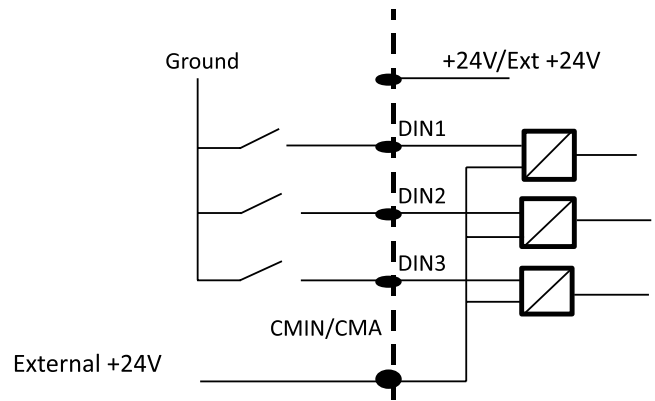

You can also use the positive and negative logic connections with the internal +24V supply.

### Installing PowerXL option board

Remove Utility line and control power from the PowerXL series drive. Install the option board in one of the slots available on the control board. To insert and remove the board, hold it in a horizontally straight position to avoid twisting the connector pins.

---

**⚠ CAUTION**

---

To prevent board damage, option cards and fieldbus boards must not be installed, removed or replaced while utility line or control power is applied to the PowerXL Drive.

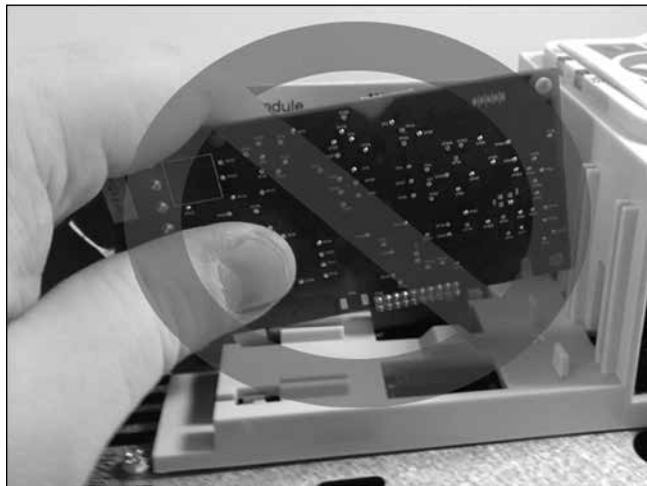
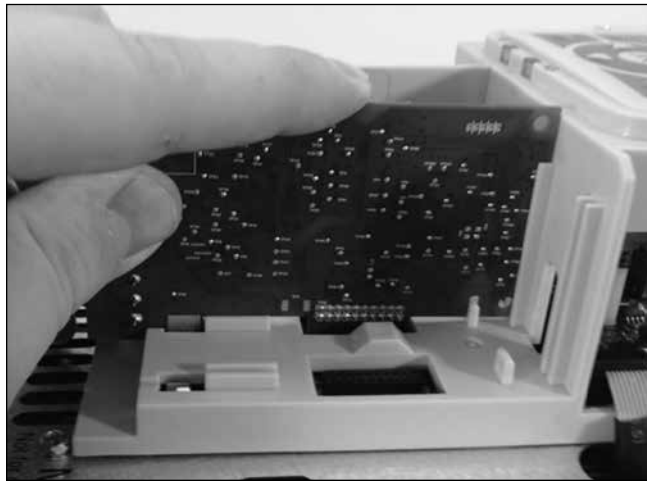

Verify the board fits tightly in the metal clamp and plastic groove. If the board seems to be difficult to install in the slot, you should confirm that you are using one of the allowed slots for the option board.

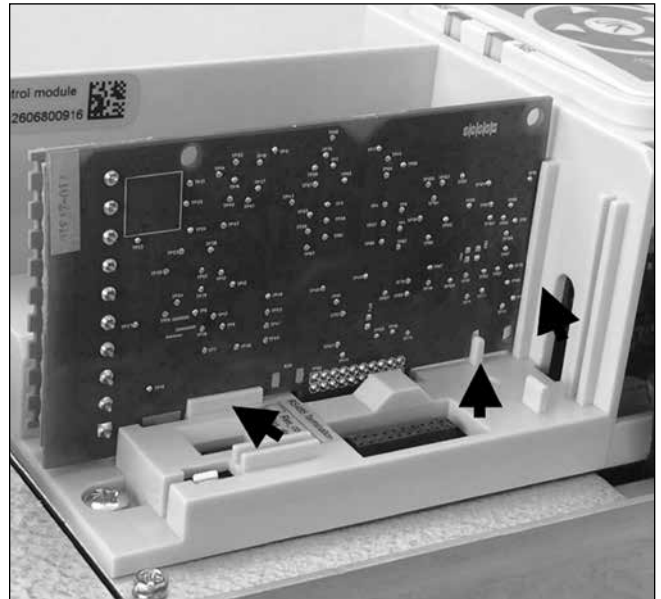

**Note:** Check that the DIP switch settings on the board correspond to your need.

### Control wiring

Digital I/O and 24 Vdc can use Stranded Cu or Solid Cu wire as specified below. Analog signal PT100 must use shielded cables. **Table 3** shows the wire sizes available. I/O terminals allow for 5.00 mm connectors.

**Table 3. Wire sizes**

Wire type	Wire size	Terminal torque
Solid Cu -90°C	12–28 AWG (0.2–2.5 mm <sup>2</sup> )	4.5 in-lb (0.5 Nm)
Stranded Cu -90°C	12–30 AWG (0.2–2.5 mm <sup>2</sup> )	4.5 in-lb (0.5 Nm)

## PowerXL Series Overview

### EMC directive

For the electrical equipment installed in the EMC, directive states that the equipment must not disturb the environment and must be immune to other electromagnetic disturbances in the environment. **Table 4** indicates the requirements for the control wiring to meet this directive.

**Table 4. Control wiring requirements**

Item	Directive
Product	IEC 61800-2
Safety	UL 508C, IEC/EN 61800-5-1
EMC (at default settings)	Immunity: EN/IEC 61800-3, 2nd environment
	Radiated emissions: EN/IEC 61800-3 (Transient Testing included), 1st environment
	Conducted emissions: EN/IEC 61800-3
	Category C1: is possible with external filter connected to drive. Please consult factory
	Category C2: with internal filter maximum of 10m motor cable length
	Category C3: with internal filter maximum of 50m motor cable length

### Control cable grounding

It is recommended that the shielded cables be grounded as shown in **Figure 7**. Strip the cable insulation required allowing attachment to the frame with the grounding clamp.

**Figure 8. Control cable grounding**

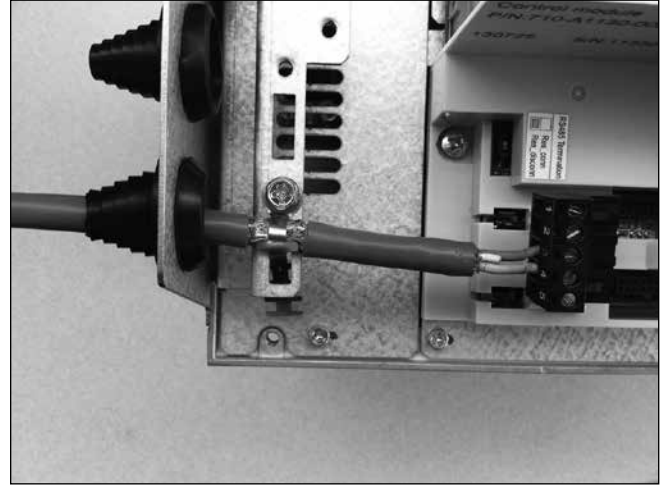

### Option card introduction

Optional cards are connected to PowerXL control board in two slots. For I/O cards, various inputs and outputs can be used for control algorithms. Outputs also can be used for status of the motor.

**Table 5. I/O card input/output**

Board type	Allowed slots	ID	Digital input (DI)	Digital output (DO)	Analog input (AI) (mA/V)	Analog output (AO) (mA/V)	PT100 input
I01 - DXG-EXT-3DI3DO1T	A, B	0x3012	3	3	—	—	—
I02 - DXG-EXT-1AI2AO	A, B	0x3013	—	—	1	2	—
I03 - DXG-EXT-3R0	A, B	0x3014	—	3	—	—	—
I04 - DXG-EXT-THER1	A, B	0x3015	—	—	—	—	3
I05 - DXG-EXT-6DI	A, B	0x3016	6	—	—	—	—

## DXG-EXT-3DI3D01T - IO1—3 x DI, 3 x DO, 1 x Thermistor, 24 Vdc/EXT option card

### Description

I/O board has 3 digital inputs, 3 digital outputs, 1 thermistor input used with 2 of the standard 3 inputs, and 24 Vdc Input and Output. It can be placed in either Slot A or B. Control terminals are keyed so they cannot be inserted incorrectly. Digital inputs and outputs are optically isolated from the main processor, Commons are connected together.

**Table 6. Digital input/output ratings**

#### Digital inputs

Specification	Value
Input points	3 points, 1 common line
Rated input voltage	24 Vdc (current sinking)
On state voltage	18V to 30 Vdc
Steady state current	5 mA
Off state voltage	0 to 10 Vdc
Input impedance	>5k ohm
Input logic	Positive logic and negative logic
Isolation voltage	500 Vdc

#### Digital Outputs

Specification	Value
Output points	3 output points, 1 common line
Output type	OC (Open-Collector)
Rated output voltage	24 Vdc
Output voltage range	Max. 36 Vdc
Output current range	Max. 50 mA

**Table 7. 24V rating**

Power supply	Specification
Rated voltage	24 Vdc
Power consumption from 24 Vdc_IN	Voltage +24 Vdc $\pm$ 10%, max. ripple voltage 100 mV rms Maximum current 1A 1A external fuse (no internal short-circuit protection is provided on the base board for the external 24V input)
Power requirement for 24 Vdc_OUT	Total combined load on all available 24 Vdc out terminals for all optional cards must not exceed 250 mA. The maximum load on the 24 Vdc out per board is 150 mA

DXG-EXT-3DI3DO1T - IO1—3 x DI, 3 x DO, 1 x Thermistor, 24 Vdc/EXT option card

Figure 9. IO1 board layout

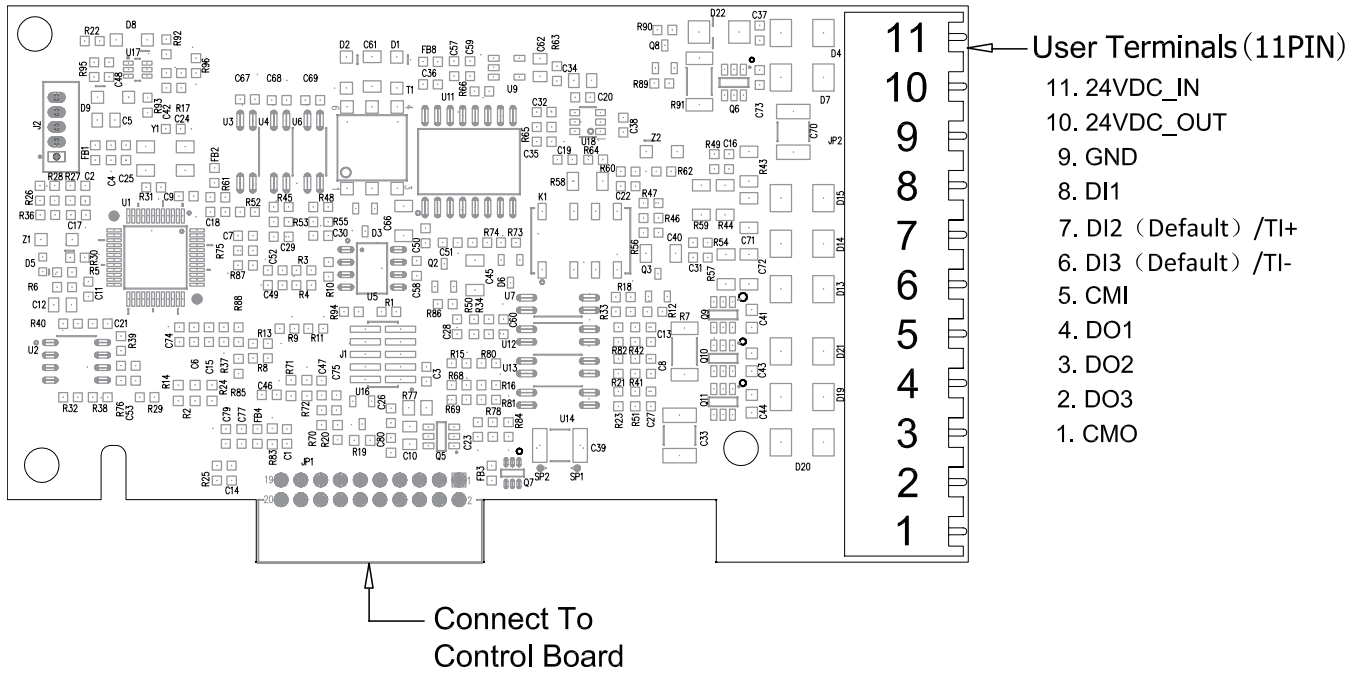
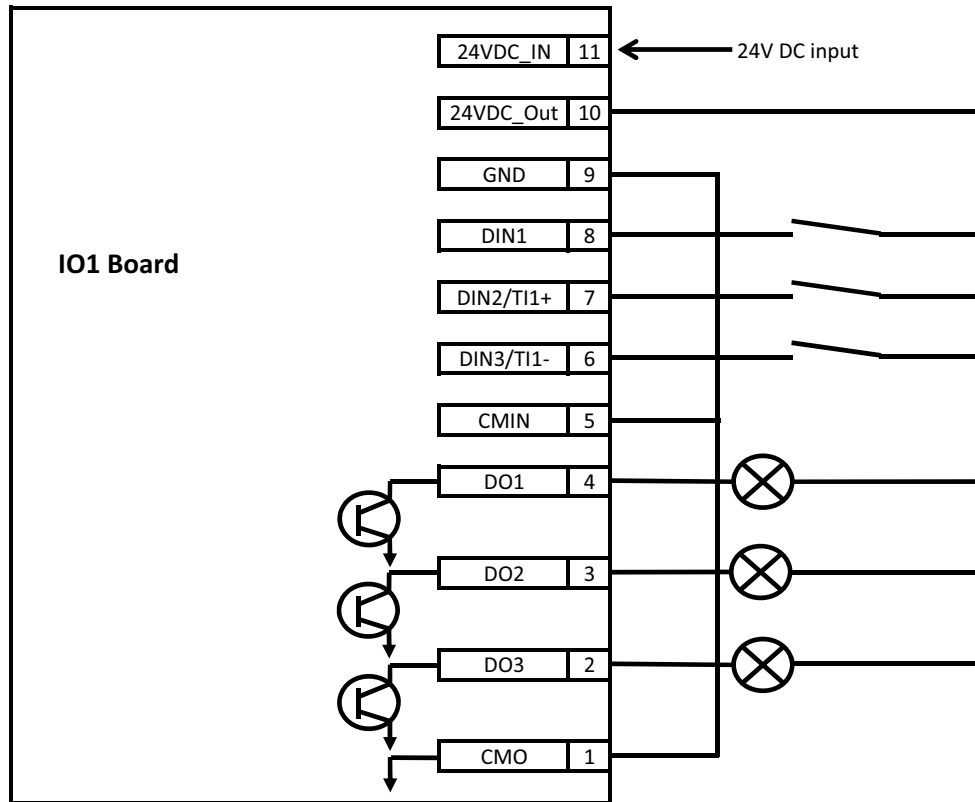

Figure 10. IO1 board wire layout



**Note:** If the thermistor inputs are selected, it removes 2 of the digital inputs to be used as the thermistor inputs, inputs DIN2 and DIN3 become thermistor inputs with 4.7K ohm switching point.

Table 8. IO1 control terminals

Terminal	Signal	Technical
1	CMO	Digital output common
2	Digital output 3	Open collector, 50 mA/36V
3	Digital output 2	Open collector, 50 mA/36V
4	Digital output 1	Open collector, 50 mA/36V
5	CMIN	For digital input
6	Digital input 3, TI-	24V: "0" <= 10V, "1" >=18V, Ri >5k(Ohm symbol)
7	Digital input 2, TI+	24V: "0" <= 10V, "1" >=18V, Ri >5k(Ohm symbol)
8	Digital input 1	24V: "0" <= 10V, "1" >=18V, Ri >5k(Ohm symbol)
9	Ground	Ground for 24 Vdc IN/24 Vdc OUT
10	24 Vdc OUT	Control voltage output; voltage for switches etc.; max. current 150 mA; short-circuit protected
11	24 Vdc IN	24 Vdc input

**Notes**

1. CMIN is Digital Input Common Line. Sink and Source available. Digital Input is isolated from 24 Vdc\_IN, 24 Vdc\_OUT and GND
2. CMO is Digital Output ground. Digital Output is isolated from 24 Vdc\_IN, 24 Vdc\_OUT and GND
3. Thermistor input on DI2 and DI3 is switched by Relay. When Thermistor function is turned on, TI1+ is combined with DIN2 and TI1- is combined with DIN3
4. Total combined load on available 24 Vdc out terminals for all optional cards must not exceed 250 mA. The maximum load on the 24 Vdc out per board is 150 mA

## Digital inputs

The 3 digital input functions can be configured for various functions in the PowerXL drive. To configure these inputs, the standard Digital inputs menu will allow for selecting its function. DigIN: X indicates one of the onboard inputs. The option DigIN: X: IO1:Y will select one of the inputs on the IO1 card; the first X being the slot it is located in, A or B, and the second Y being the input used. **Figure 10** is an example on how to navigate to the menu.

**Figure 11. PowerXL DG1 Digital input signal programming**

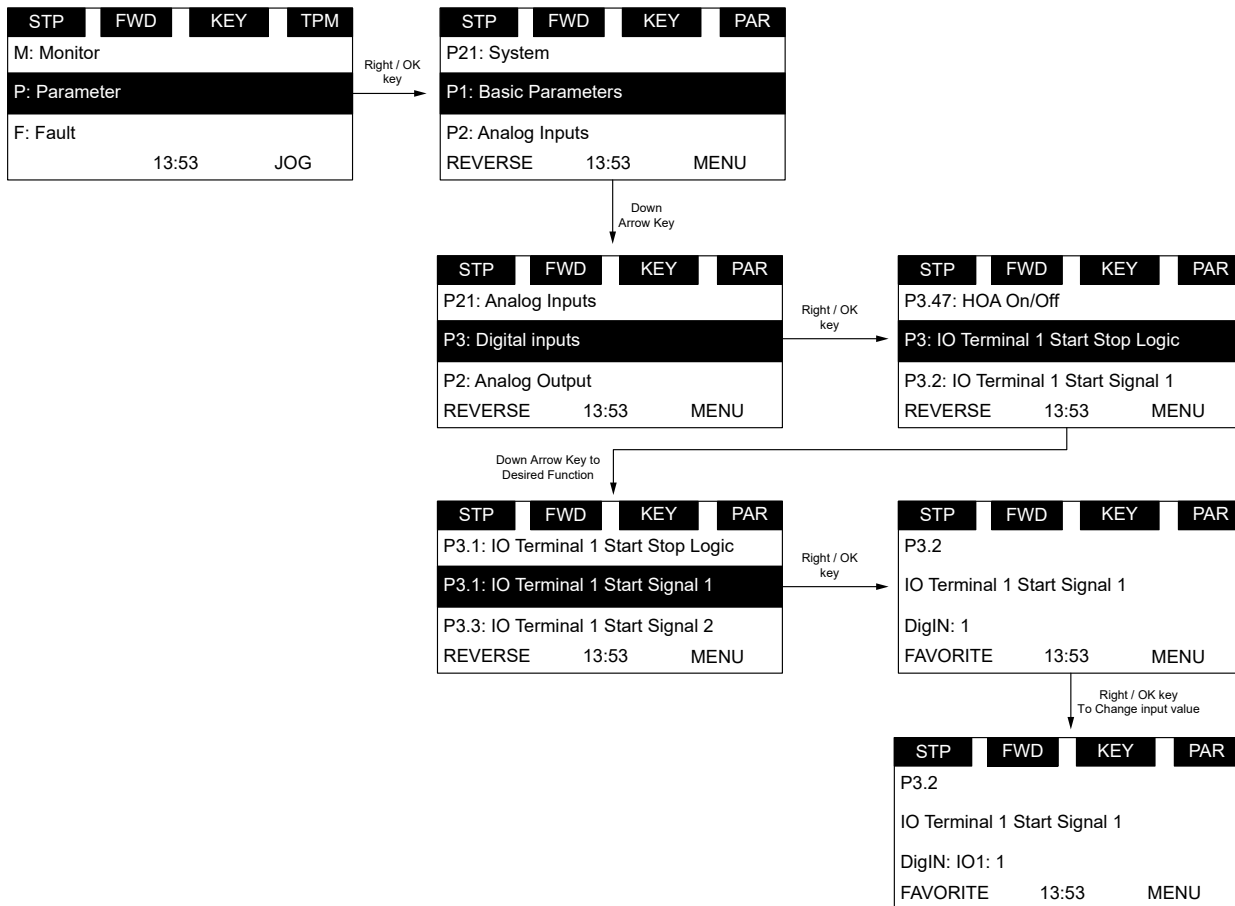
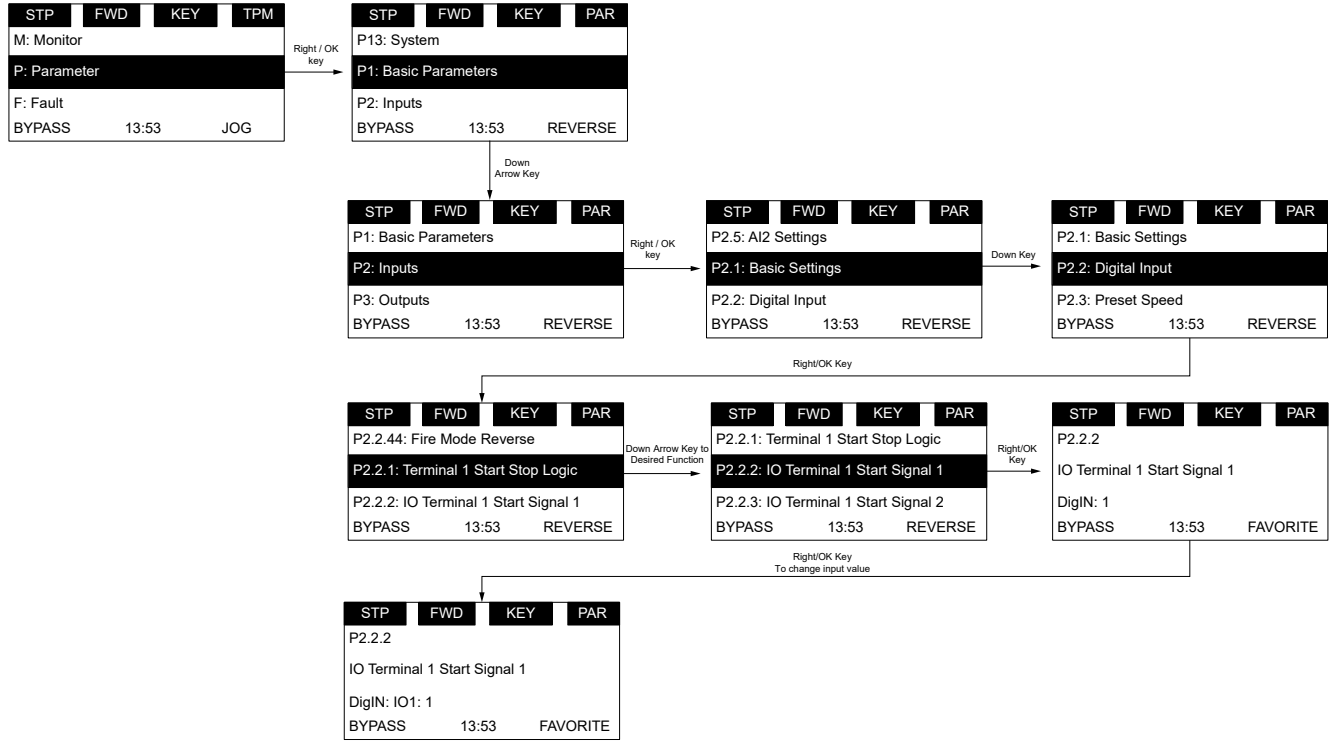



Figure 12. PowerXL DH1 Digital input signal programming



## Digital outputs

The 3 digital output functions can be configured to various functions in the PowerXL drive. To configure these inputs, there are parameters in the option card menu for each of the outputs that will allow for selecting its function.

**Figure 13. DG1 Digital output signal programming**

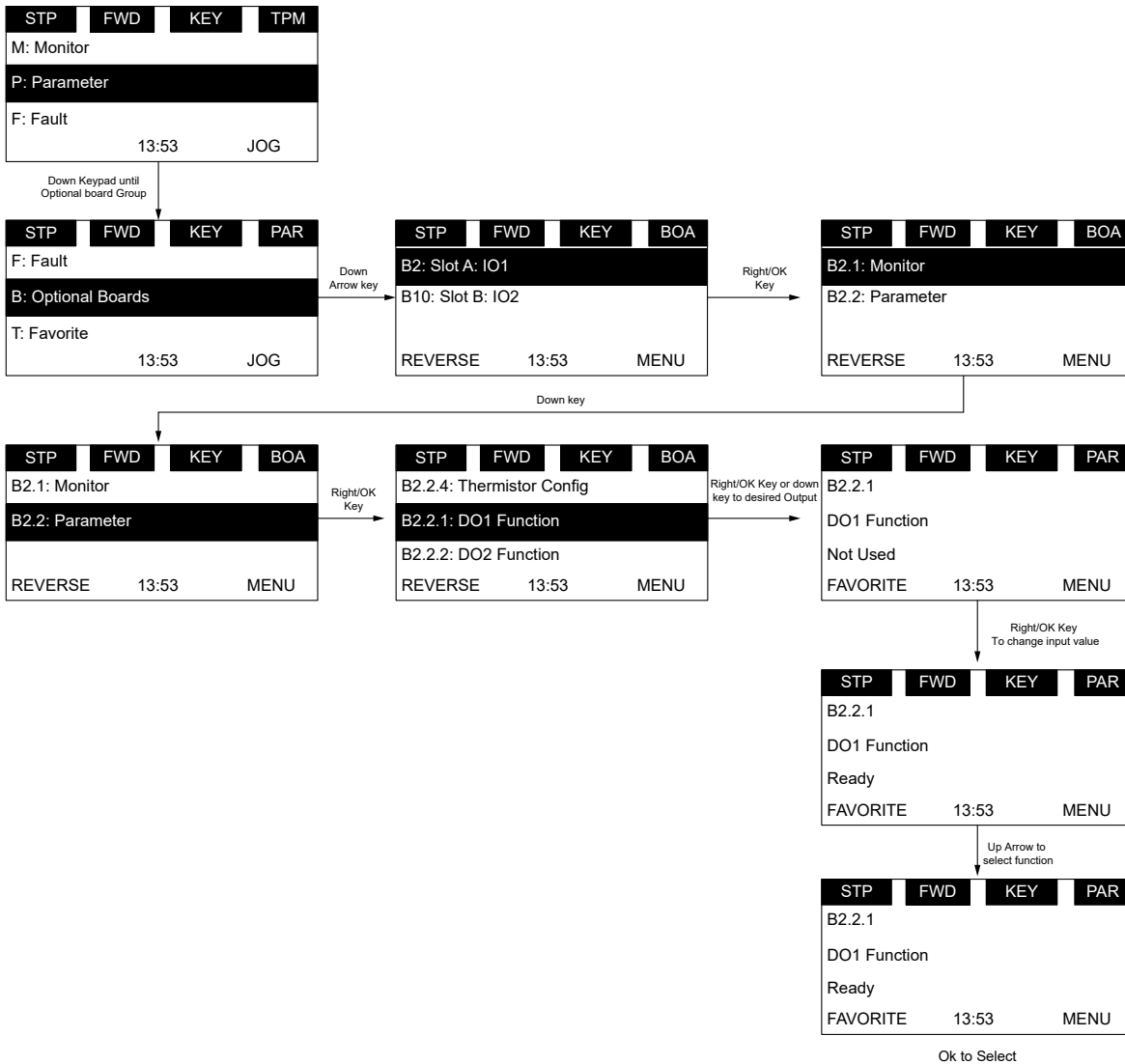
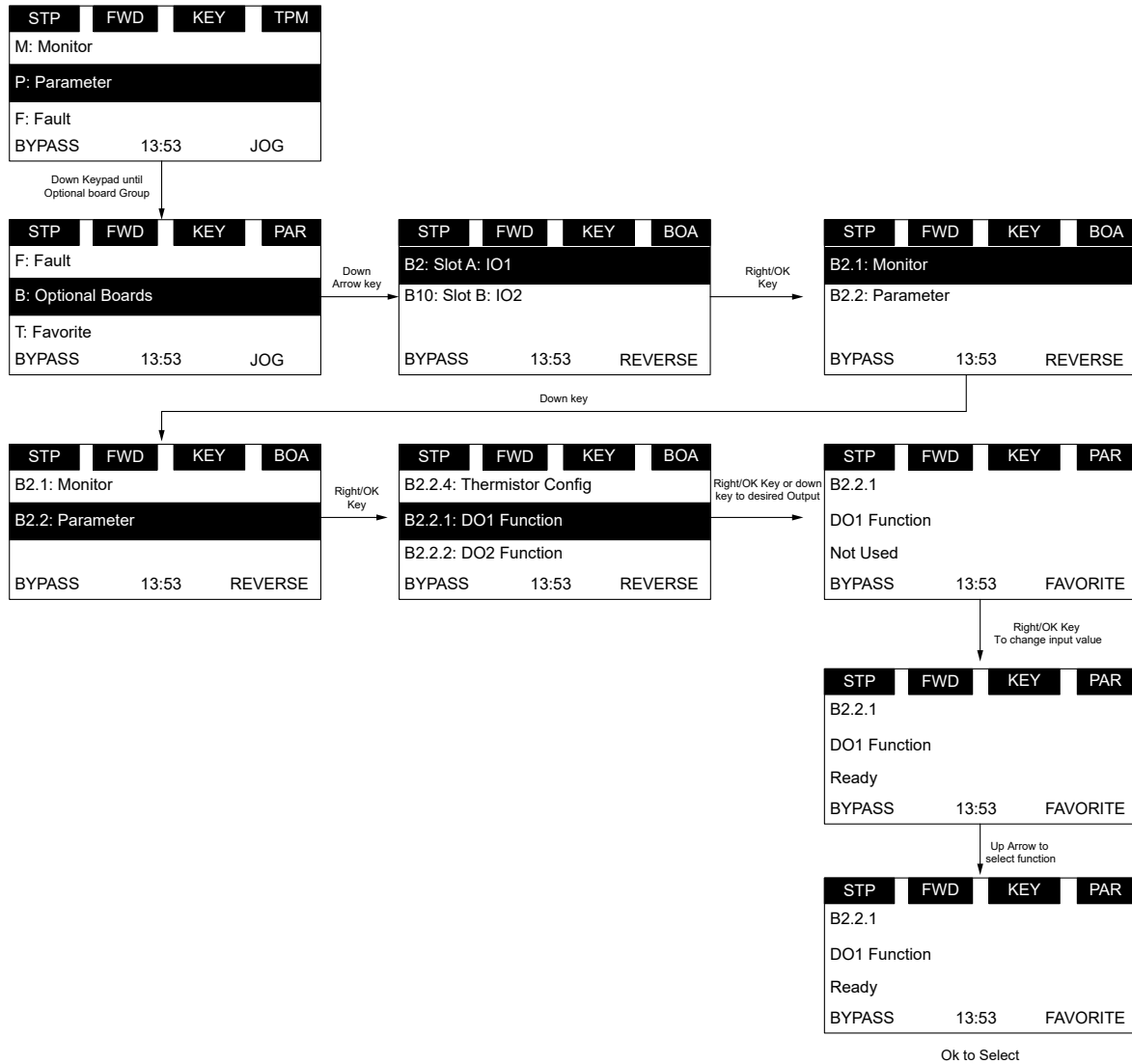

Figure 14. DH1 Digital Output Signal Programming



## Thermistor input

The signal thermistor input needs to be configured before use. It will switch states at 4.7 k ohm.

**Table 9. Thermistor input configuration**

PTC Resistance	PTC State
>4.7K	Open
1.8K to 10	Normal
<10	Short
No PTC	Not configured

**Figure 15. DG1 Thermistor parameter setting**

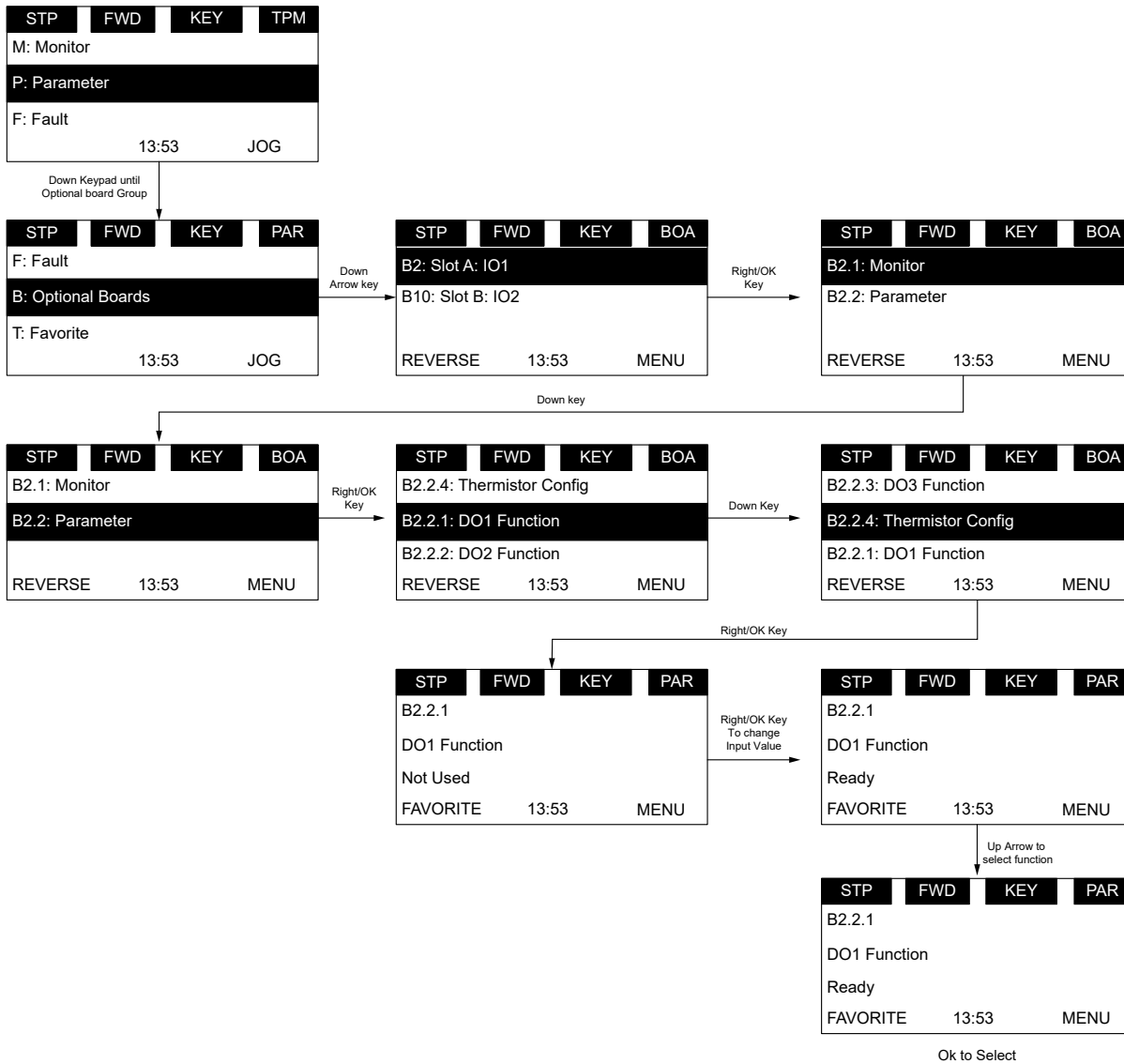
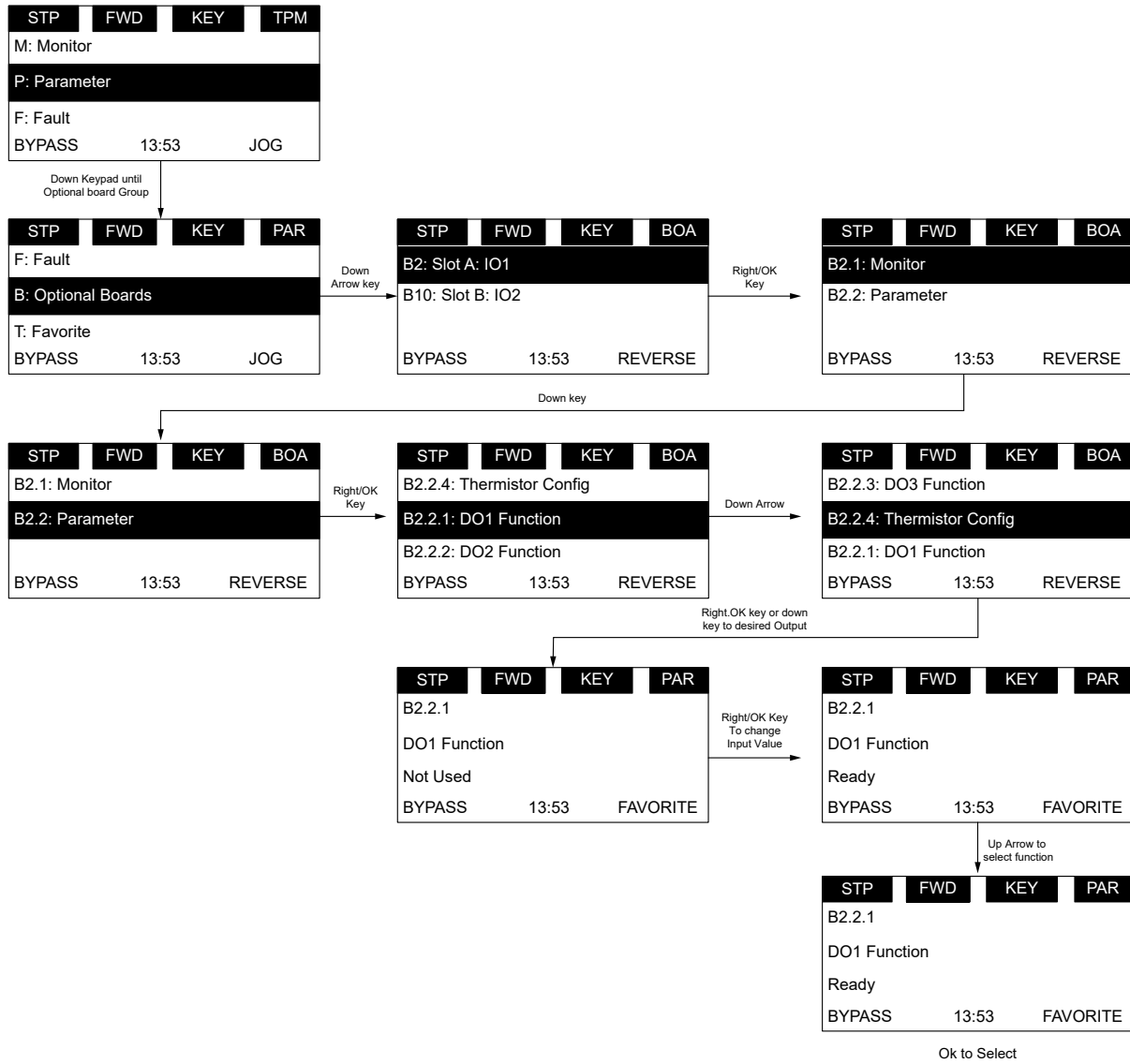

Figure 16. DH1 Thermistor Parameter setting



## IO1 Board parameters

**Table 10. IO1 Board parameters**

### Monitor menu—BX.1

Code	Parameter	Min.	Max.	Default	Unit	ID (Slot A/Slot B)	Description	R/RW
BX.1.1	Board status					883/910	Option board status B0 – DCOM Comm fault B1 – Board HW Fault B2 – IO1 24Volt Overload Fault B3 – Fieldbus Fault	R
BX.1.2	Firmware version					1064/1067	Option board firmware	R
BX.1.3	DI1, DI2, DI3					889/915	Digital input status	R
BX.1.4	DO1, DO2, DO3					888/914	Digital output status	R
BX.1.5	Thermistor state					887/913	Thermistor configure	R
BX.1.6	Thermistor resistor					891/917	Thermistor resistance value	R

### Parameter menu—BX.2

Code	Parameter	Min.	Max.	Default	Unit	ID (Slot A/Slot B)	Description	R/RW
BX.2.1	DO1 Function select			0		241/244	Selects the function for the digital output	RW
BX.2.2	DO2 Function select			0		242/245	Selects the function for the digital output	RW
BX.2.3	DO3 Function select			0		243/246	Selects the function for the digital output	RW
BX.2.4	Thermistor configuration	0	1	0		890/916	Configures the thermistor as active 0: Digital Input 1: Thermistor Input	RW

**Note:** X is indicating that it could be in slot A or slot B, which would change the value shown.  
See Application Manual for settings available.

## DXG-EXT-1AI2A0 - IO2—1 x AI, 2 x AO option card

### Description

IO board has 1 analog input that can be configured as voltage ( $\pm 10\text{V}$ ) or current (0 to 20 mA) and 2 analog outputs that can be configured as voltage (0 to 10V) or current (0 to 20 mA). DIP switches on the option card are used to configure along with parameter settings.

**Table 11. IO2 analog ratings**

#### Analog input

Item	Voltage input	Current input
Number of inputs	1	1
Input type	Single-end	Single-end
Input range	$\pm 10\text{ Vdc}$	0 (4)–20 mA
Input impedance	$>200\text{ k ohm}$	$\leq 250\text{ ohm}$
Resolution	10 bits/0.1%	10 bits/0.1%
Accuracy	$\pm 1\%$ of full display	$\pm 1\%$ of full display
Maximum permanent allowed overload (no damage)	30 Vdc	30 mA DC
Insulation (Analog $\leftrightarrow$ Control board MCU)	500 Vac, 800 Vdc	500 Vac, 800 Vdc

**Note:** Inputs and Outputs are galvanically Isolated from the main control board. GND's /AI- are common for each channel.

#### Analog output

Item	Voltage input	Current input
Number of outputs	2	2
Output range	0–10 Vdc	0 (4)–20 mA DC
Load impedance	$>1\text{ k ohm}$	$<500\text{ ohm}$
Application load type	Resistive load	Resistive load
Resolution	10 bits/0.1%	10 bits/0.1%
Accuracy	$\leq \pm 2\%$	$\leq \pm 2\%$
Load resistance too high at the current output	No protection and detection of this kind of error	
Insulation (Analog $\leftrightarrow$ Control board MCU)	500 Vac, 800 Vdc	500 Vac, 800 Vdc

**Note:** Inputs and Outputs are galvanically Isolated from the main control board. GND's /AO- are common for each channel.

# DXG-EXT-1AI2AO - IO2—1 x AI, 2 x AO option card

Figure 17. IO2 board layout

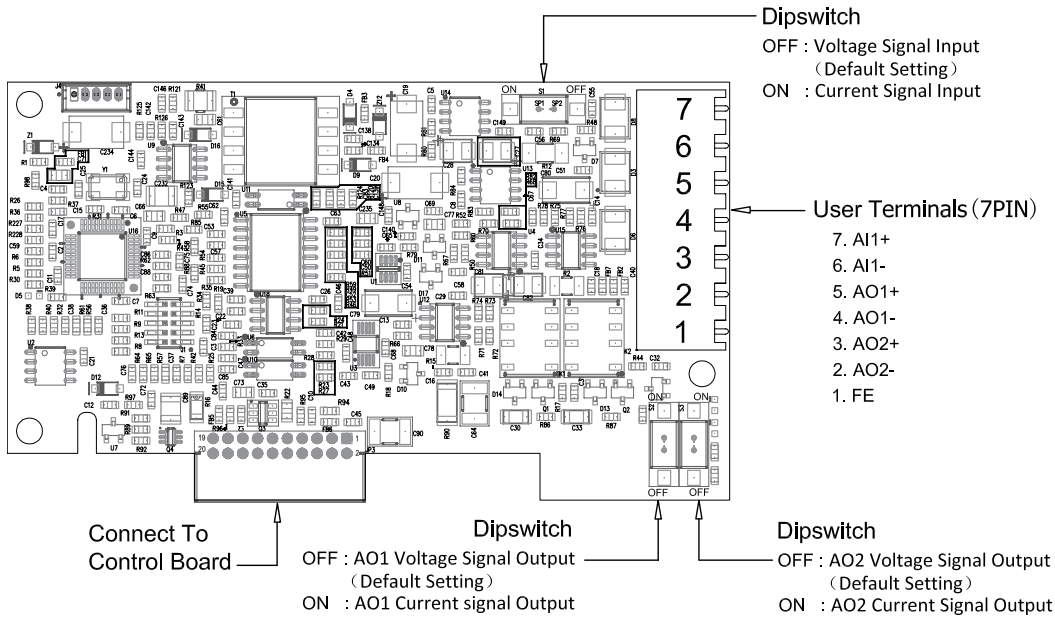

Figure 18. IO2 board wire layout

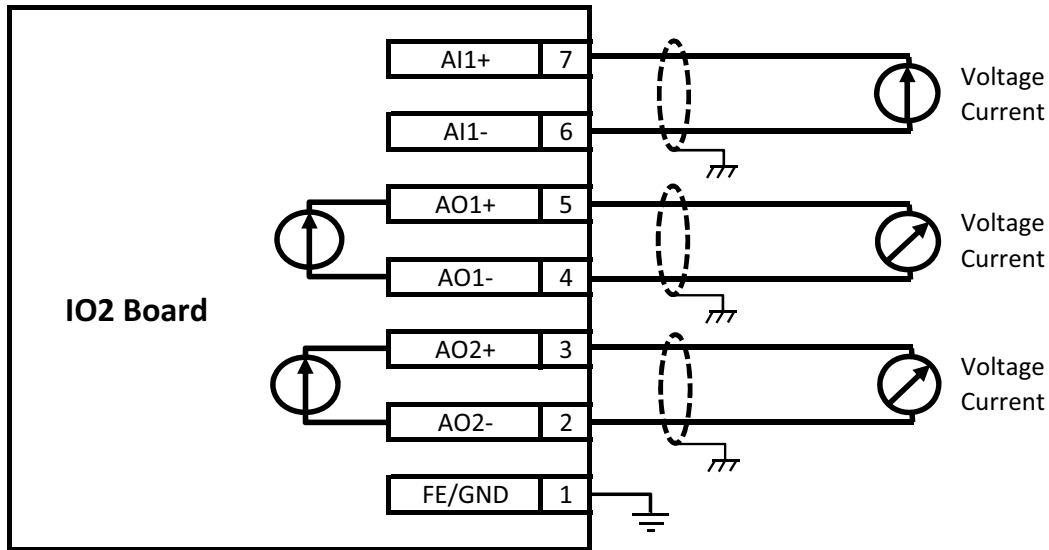

Table 12. IO2 board terminals

Terminal	Signal	Technical
1	FE	Connect cable shield
2	AO2-	Current: 0 (4)–20 mA, RL max. 500 ohms
3	AO2+	Voltage: 0–10V, RL >1k ohm (default setting)
4	AO1-	Current: 0 (4)–20 mA, RL max. 500 ohms
5	AO1+	Voltage: 0–10V, RL >1k ohm (default setting)
6	AI-	Current: 0 (4)–20 mA (Ri = 250 ohms)
7	AI+	Voltage: –10 to +10V (Ri > 200k ohms (default setting)



## IO2 Board parameters

Parameters are all listed in the Optional board menu for this card.

Figure 19. DG1 IO2 Parameter structure

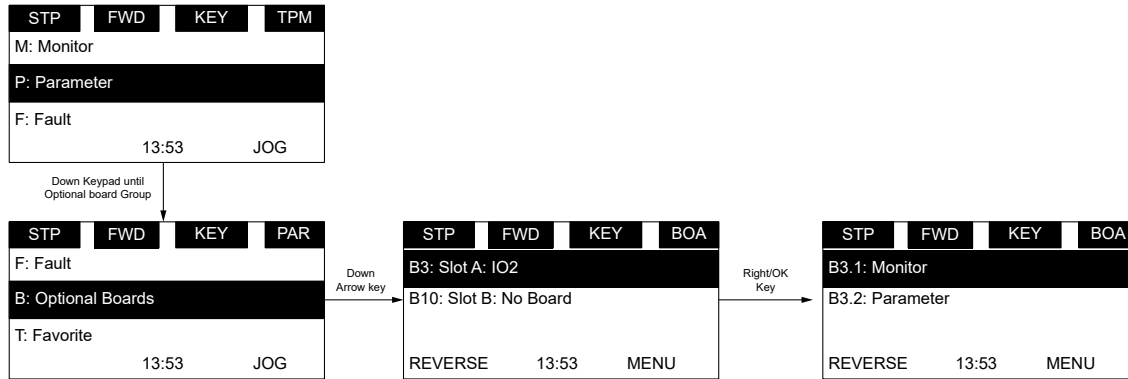

Figure 20. DH1 IO2 Parameter structure

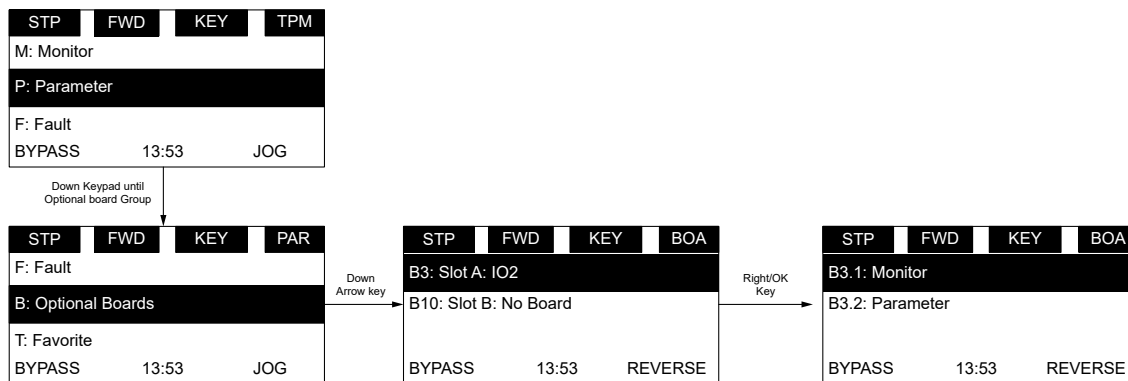

Table 13. IO2 Board parameters

### Monitor menu—BX.1

Code	Parameter	Min.	Max.	Default	Unit	ID (Slot A/Slot B)	Description	R/RW
BX.1.1	Board status					883/910	Option board status B0 – DCOM comm fault B1 – Board HW fault B2 – IO1 24Volt overload fault B3 – Fieldbus fault	R
BX.1.2	Firmware version					1064/1067	Option board firmware	R
BX.1.3	AI1 Value					894/920	Analog input status	R
BX.1.4	AO1 Value					897/922	Analog output status	R
BX.1.4	AO2 Value					899/924	Analog output status	R

## DXG-EXT-1AI2AO - IO2—1 x AI, 2 x AO option card

### Parameter menu—BX.2

Code	Parameter	Min.	Max.	Default	Unit	ID (Slot A/Slot B)	Description	R/RW
BX.2.1	AI1 Mode	0	2	0		893/919	Analog input 1 Mode 0: 0 to 20 mA 1: 0 to 10V 2: -10V to +10V	RW
BX.2.2	AI1 Range	0	2	0		124/129	Analog input 1 signal range 0: 0 to 100% 1: 20 to 100% 2: Customized	RW
BX.2.3	AI1 Custom min	0	100	0	%	125/130	Analog input 1 custom minimum range	RW
BX.2.4	AI1 Custom max	0	100	100		126/131	Analog input 1 custom maximum range	RW
BX.2.5	AI1 Filter time	0	10	0.1	s	123/128	Analog input 1 filter time	RW
BX.2.6	AI1 Invert	0	1	0		127/132	Analog input 1 signal inversion 0: Not Inverted 1: Inverted	RW
BX.2.7	AO1 Mode	0	1	0		896/922	Analog output mode 0: 0 to 20 mA 1: 0 to 10V	RW
BX.2.8	AO1 Function			0		235/275	Analog output 1 function	RW
BX.2.9	AO1 Min	0	1	0		238/276	Analog output minimum value 0: 0V/0 mA 1: 2V/4 mA default 0V/0 mA	RW
BX.2.10	AO1 Filter time	0	10	1	s	236/277	Analog output filter time range	RW
BX.2.11	AO1 Scale	0	100	100	%	239/278	Analog output 1 scale	RW
BX.2.12	AO1 Invert	0	1	0		237/279	Analog output 1 signal inversion 0: Not Inverted 1: Inverted	RW
BX.2.13	AO1 Offset	0	9	0	%	240/280	Analog output minimum offset	RW
BX.2.14	AO2 Mode	0	1	0		898/924	Analog output mode 0: 0 to 20 mA 1: 0 to 10V	RW
BX.2.15	AO2 Function			0		269/281	Analog output function	RW
BX.2.16	AO2 Min	0	1	0		270/282	Analog output minimum value 0: 0V/0 mA 1: 2V/4 mA	RW
BX.2.17	AO2 Filter time	0	10	1	s	271/283	Analog output filter time	RW
BX.2.18	AO2 Scale	0	100	100	%	272/284	Analog output scale	RW
BX.2.19	AO2 Invert	0	1	0		273/285	Analog output signal inversion 0: Not Inverted 1: Inverted	RW
BX.2.20	AO2 Offset	0	9	0	%	274/286	Analog output minimum offset	RW

**Note:** X is indicating that it could be in slot A or slot B, which would change the value shown.  
See Application Manual for settings available.

## DXG-EXT-3R0 - IO3—3 x Relay dry contact (2NO + 1NO/NC) option card

### Description

IO board has 2 form A dry contacts and 1 form C dry relay. The relay functions can be selected via parameters based off of various drive monitoring values.

**Table 14. IO3 board rating**

Specification	Value
Number of contacts	2 Form A (NO) and 1 Form C (NO, NC)
Continuous capacity	<2A rms
Operating voltage	250 Vac, 24 Vdc
Switching capacity	24 Vdc/8A; 250 Vac/8A
Minimum switching load	10 mA at 5 Vdc
Isolation type	Relay coil

**Figure 21. IO3 board layout**

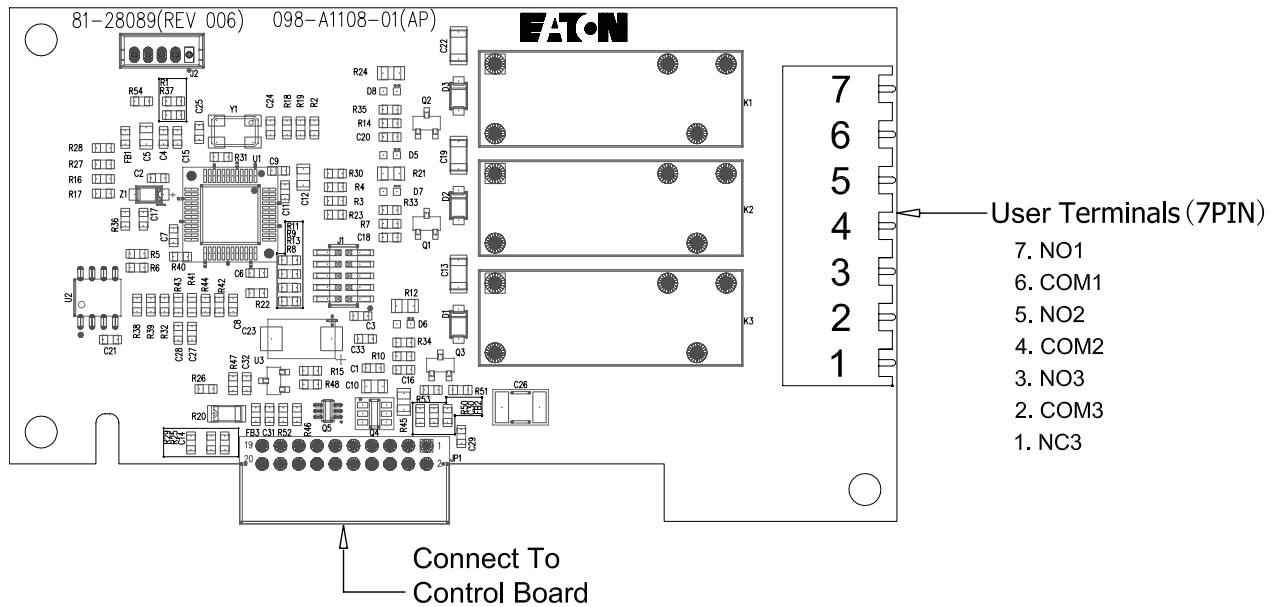

# DXG-EXT-3R0 - IO3—3 x Relay dry contact (2NO + 1NO/NC) option card

**Figure 22. IO3 board wire layout**

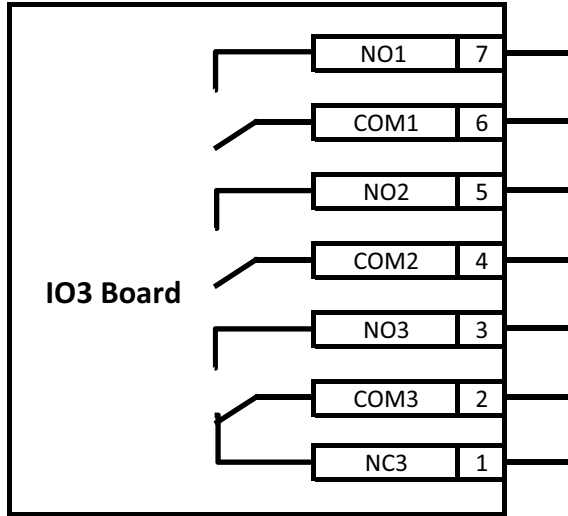

**Table 15. IO3 board terminals**

Terminal	Signal	Technical
1	NC3-R03/common	Switching capacity: 24 Vdc/8A; 250 Vac/8A; 125 Vdc/0.4A Min. switching load: 5V/10 mA
2	COM3	
3	NO3-R03/normal close	Switching capacity: 24 Vdc/8A; 250 Vac/8A; 125 Vdc/0.4A Min. switching load: 5V/10 mA
4	COM2	
5	NO2-R02/normal open	Switching capacity: 24 Vdc/8A; 250 Vac/8A; 125 Vdc/0.4A Min. switching load: 5V/10 mA
6	COM1	
7	NO1-R01/normal open	Switching capacity: 24 Vdc/8A; 250 Vac/8A; 125 Vdc/0.4A Min. switching load: 5V/10 mA

## IO3 Board parameters

**Figure 23. DG1 Parameter location**

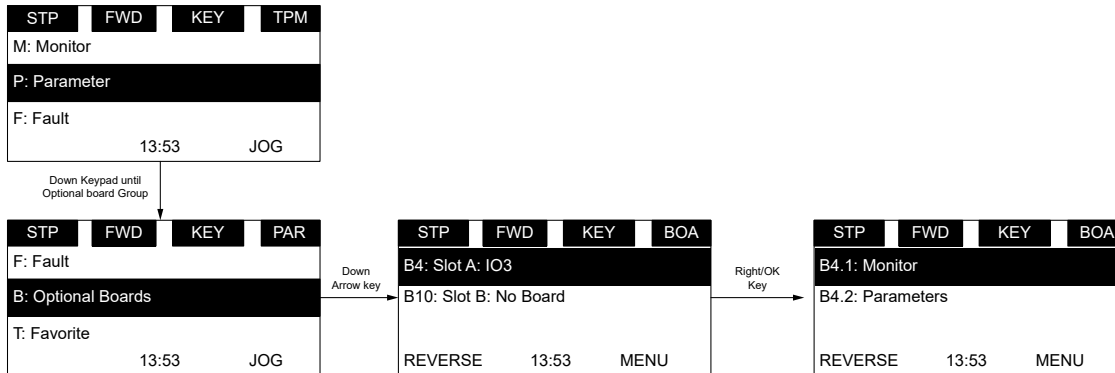

Figure 24. DH1 IO3 Parameter structure

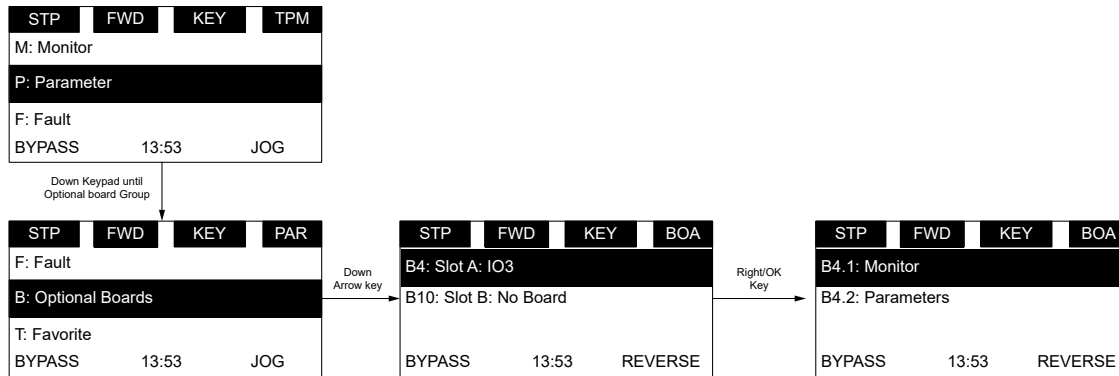

Table 16. IO3 Parameters

Monitor menu—BX.1

Code	Parameter	Min.	Max.	Default	Unit	ID (Slot A/Slot B)	Description	R/RW
BX.1.1	Board status					883/910	Option board status B0 – DCOM Comm fault B1 – Board HW fault B2 – IO1 24Volt overload fault B3 – Fieldbus fault	R
BX.1.2	Firmware version					1064/1067	Option board firmware	R
BX.1.3	Relay outputs status					900/926	Relay output status indicator	R

Parameter menu—BX.2

Code	Parameter	Min.	Max.	Default	Unit	ID (Slot A/Slot B)	Description	R/RW
BX.2.1	R01 Function select			0		540/552	R01 Function	RW
BX.2.2	R02 Function select			0		541/555	R02 Function	RW
BX.2.3	R03 Function select			0		551/556	R03 Function	RW

**Note:** X is indicating that it could be in slot A or slot B, which would change the value shown. See Application Manual for settings available.

# DXG-EXT-THER1 - IO4—3 x PT100 RTD thermistor input option card

## DXG-EXT-THER1 - IO4—3 x PT100 RTD thermistor input option card

### Description

IO board has 3 PT100 RTD inputs for motor thermal monitoring. The inputs are designed to sense temperature from  $-30^{\circ}\text{C}$  to  $+200^{\circ}\text{C}$ , warning for PT100 sensor open or short. These sensors are used to fault the drive at a user set temperature level.

**Table 17. IO4 thermistor ohm values**

Thermistor temperature	Thermistor state
>210	Open: 2
+210 to $-50$	Normal: 0
< $-50$	Short: 1
NO PTC	Not configured: 3

**Table 18. IO4 board rating**

Item	Value
Number of inputs	3
Input type	PT100
Temperature range	$-30^{\circ}\text{C}$ to $+200^{\circ}\text{C}$
Accuracy	$\leq 1.5^{\circ}\text{C}$

**Figure 25. IO4 board layout**

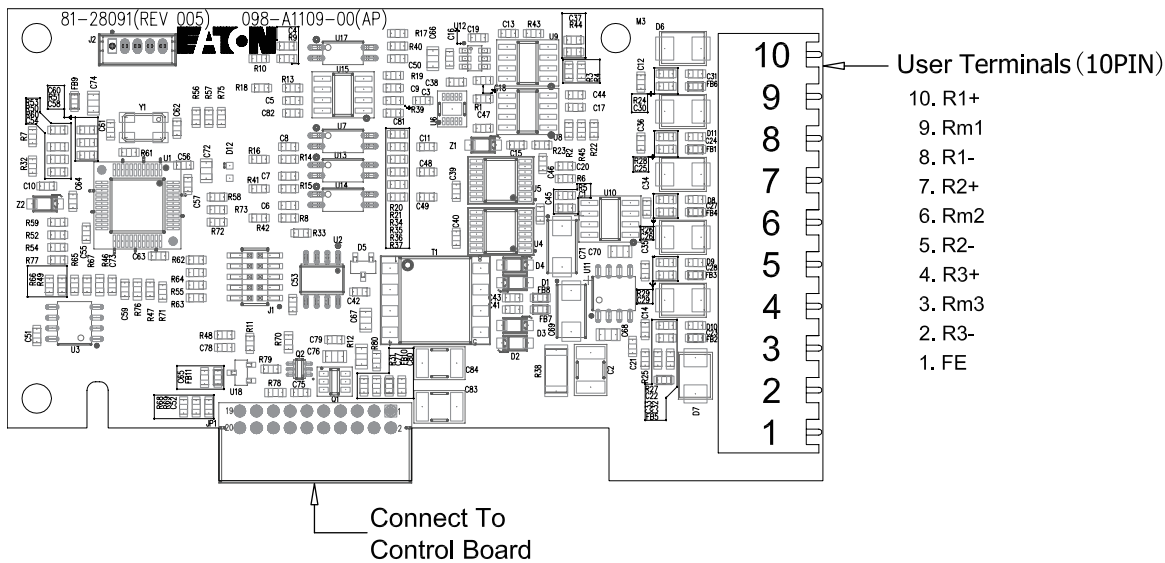

Figure 26. IO4 board wire layout - options for wiring the sensor

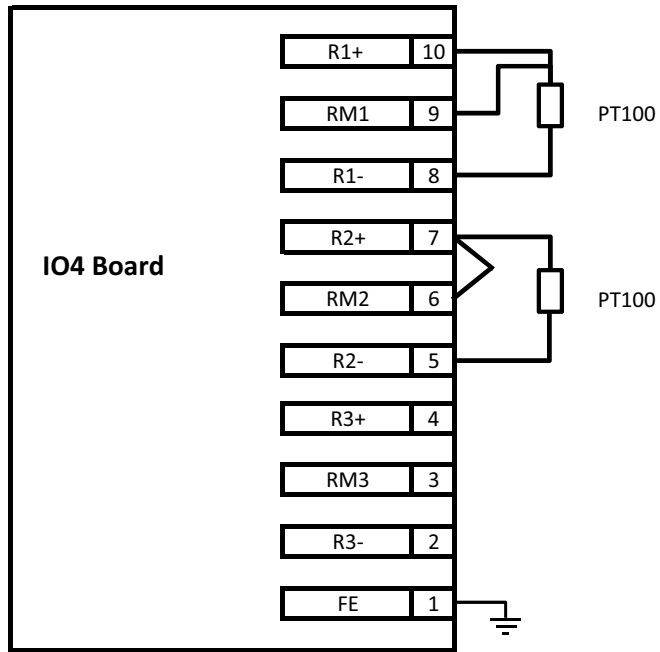

Table 19. IO4 terminal layout

Terminal	Signal	Technical
1	FE	Connect cable shield
2	R3-	PT100 Input, -30°C to +200°C, Accuracy <1.5°C
3	RM3	
4	R3+	
5	R2-	PT100 Input, -30°C to +200°C, Accuracy <1.5°C
6	RM2	
7	R2+	
8	R1-	PT100 Input, -30°C to +200°C, Accuracy <1.5°C
9	RM1	
10	R1+	

## IO4 Board parameters

Figure 27. DG1 IO4 Parameter structure

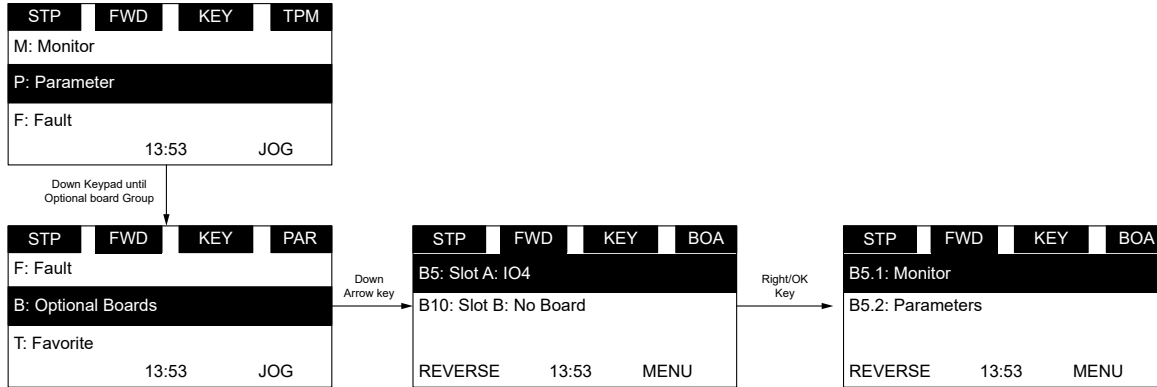
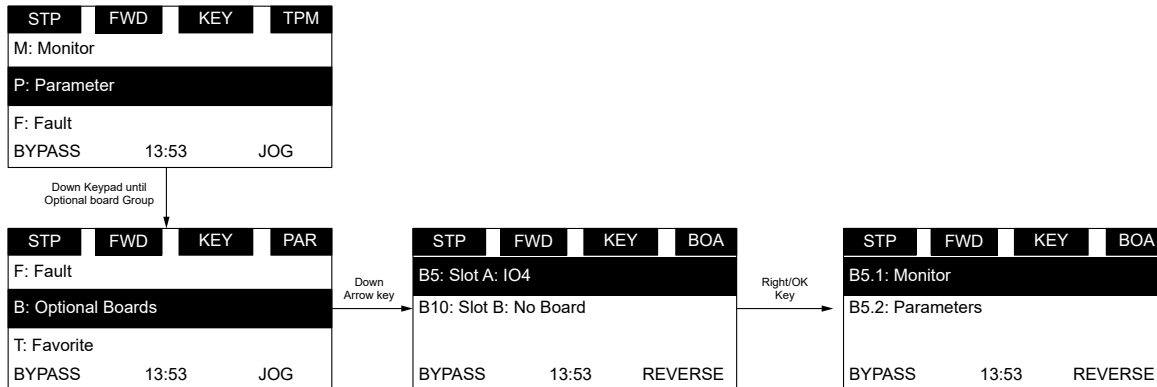

Figure 28. DH1 IO4 Parameter structure





**Table 20. IO4 parameters****Monitor menu—BX.1**

<b>Code</b>	<b>Parameter</b>	<b>Min.</b>	<b>Max.</b>	<b>Default</b>	<b>Unit</b>	<b>ID (Slot A/Slot B)</b>	<b>Description</b>	<b>R/RW</b>
BX.1.1	Board Status					883/910	Option board Status B0 – DCOM Comm Fault B1 – Board HW Fault B2 – IO1 24Volt Overload Fault B3 – Fieldbus Fault	R
BX.1.2	Firmware Version					1064/1067	Option Board Firmware	R
BX.1.3	PT100 State					905/931	PT100 board status	R
BX.1.4	PT100 Values					902/928	PT100 Temperature values	R

**Parameter menu—BX.2**

<b>Code</b>	<b>Parameter</b>	<b>Min.</b>	<b>Max.</b>	<b>Default</b>	<b>Unit</b>	<b>ID (Slot A/Slot B)</b>	<b>Description</b>	<b>R/RW</b>
BX.2.1	PT100 3, 2, 1	0	7	0		901/927	Active PT100 inputs 3, 2, 1 0: No PT100 1: 0, 0, 1 PT100 input 1 active 2: 0, 1, 0 PT100 input 2 active 3: 0, 1, 1 PT100 input 1 and input 2 active 4: 1, 0, 0 PT100 input 3 active 5: 1, 0, 1 PT100 input 3 and input 1 active 6: 1, 1, 0 PT100 input 3 and input 2 active 7: 1, 1, 1 PT100 all inputs active Default 0	RW
BX.2.2	PT100 Warning Limit					338/937	Temperature warning limit value	RW
BX.2.3	PT100 Fault Limit					339/938	Temperature fault limit value	RW

**Note:** X is indicating that it could be in slot A or slot B, which would change the value shown.

## DXG-EXT-6DI - IO5—6 x DI 120Vac / 240 Vac input option card

### Description

IO board has 6 digital inputs that are rated for a max of 240 Vac. These inputs can be configured to various functions.

**Table 21. IO5 rating**

Specification	Value
Input points	6 points, 2 common lines
Rated input voltage	120VAC/240 Vac (current sinking)
Operating frequency	50/60 Hz
On state voltage	79 Vac to 240 Vac
Steady state current	<15 mA
Off state voltage	0 to 40 Vac
Input logic	Positive logic and negative logic
Isolation voltage	1500 Vac

**Figure 29. IO5 board layout**

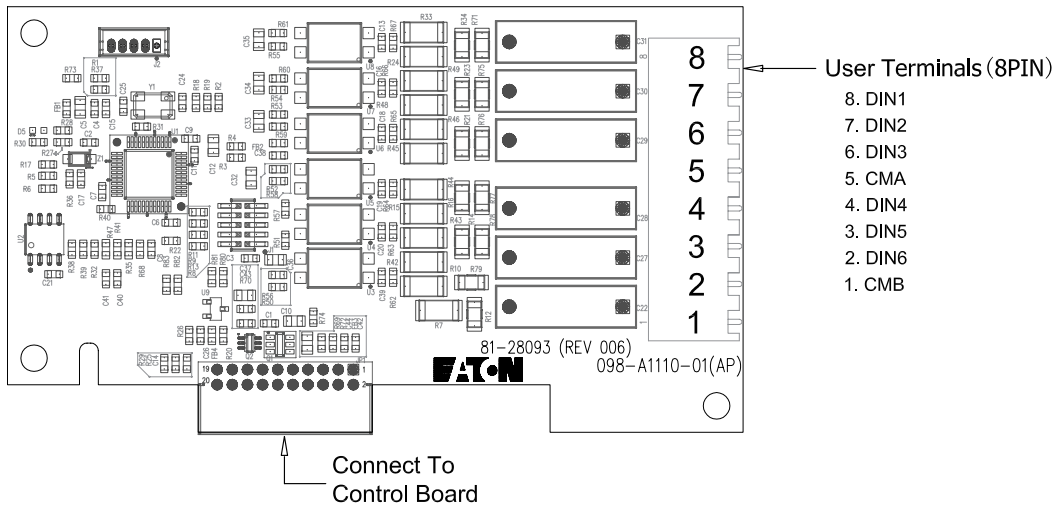

Figure 30. IO5 board wire layout

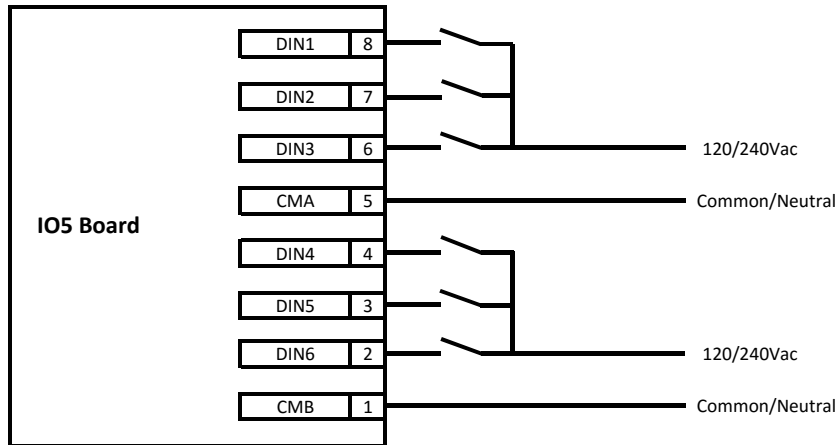

Table 22. IO5 terminal layout

Terminal	Signal	Technical
1	CMB	For digital input 4, 5, 6
2	DIN6	Digital input, 120 Vac/240 Vac, 50 Hz/60 Hz Control voltage: "0" <40 Vac, "1" >79 Vac
3	DIN5	
4	DIN4	
5	CMA	For digital input 3, 2, 1
6	DIN3	Digital input, 120 Vac/240 Vac, 50 Hz/60 Hz Control voltage: "0" <40 Vac, "1" >79 Vac
7	DIN2	
8	DIN1	

## IO5 Board parameters

Figure 31. DG1 IO5 parameter structure

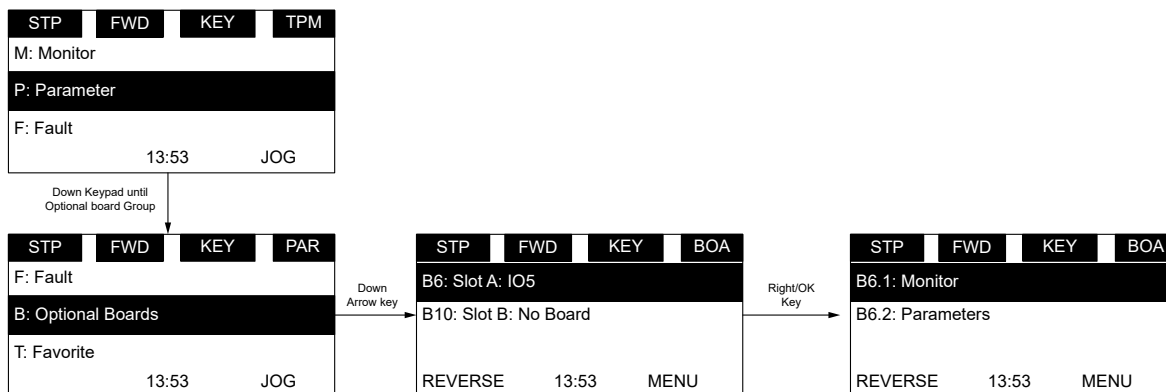

Figure 32. DH1 IO5 Parameter structure

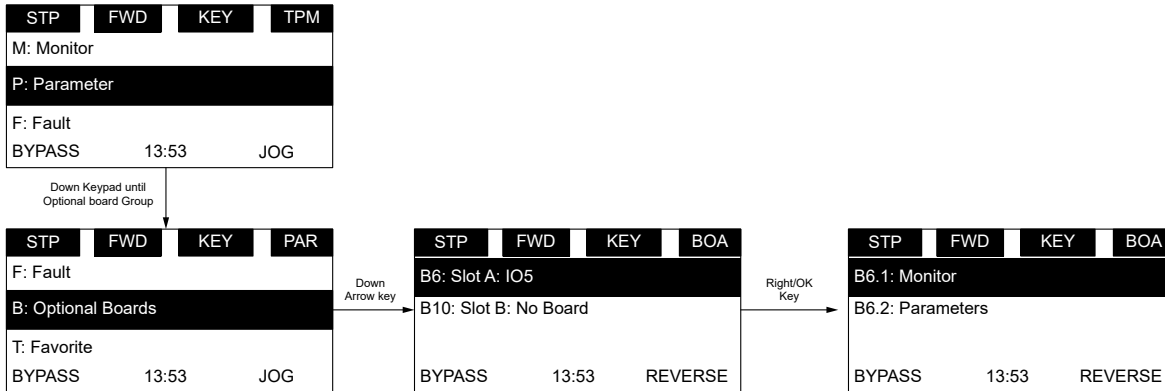

Table 23. IO5 Parameters

Monitor menu—BX.1

Code	Parameter	ID (Slot A/Slot B)	Description	R/RW
BX.1.1	Board status	883/910	Option board status B0 – DCOM Comm fault B1 – Board HW fault B2 – IO1 24Volt overload fault B3 – Fieldbus fault	R
BX.1.2	Firmware version	1064/1067	Option board firmware	R
BX.1.3	AC Digital input 1–3	908/934	Input signal status	R
BX.1.4	AC Digital input 4–6	1696/1697	Input signal status	R

**Note:** X is indicating that it could be in slot A or slot B, which would change the value shown.

Input functions are set in the drive application under the digital input selections. Depending on which slot is used, the function will be set up with DigIN: X: IO5:, X being the slot the board is placed in and Y being the input that is being used on that board.

Figure 33. DG1 Input functions

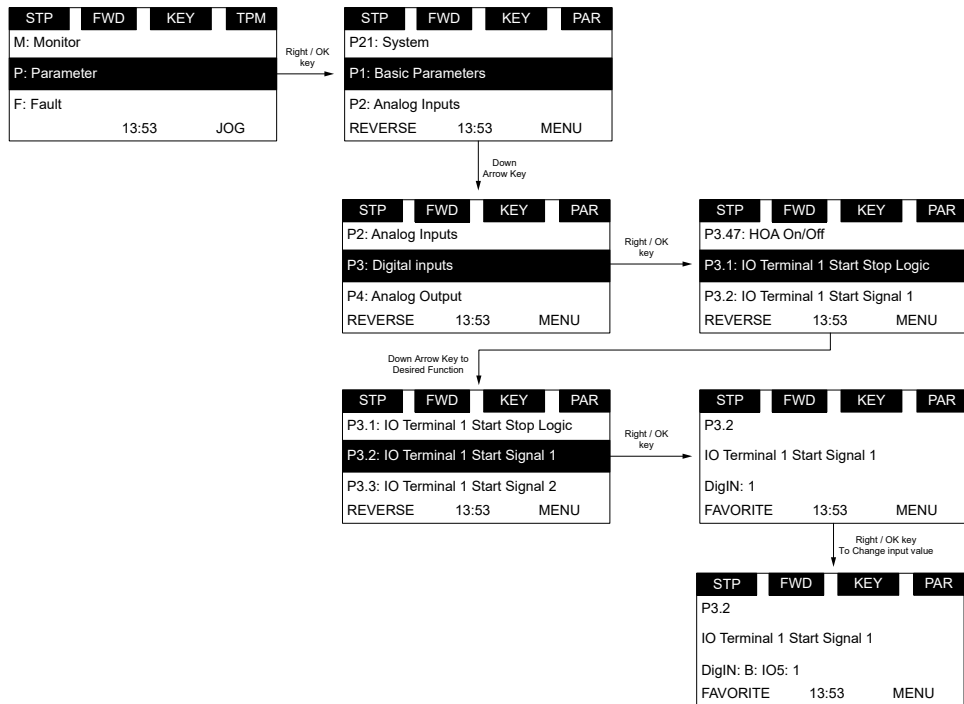
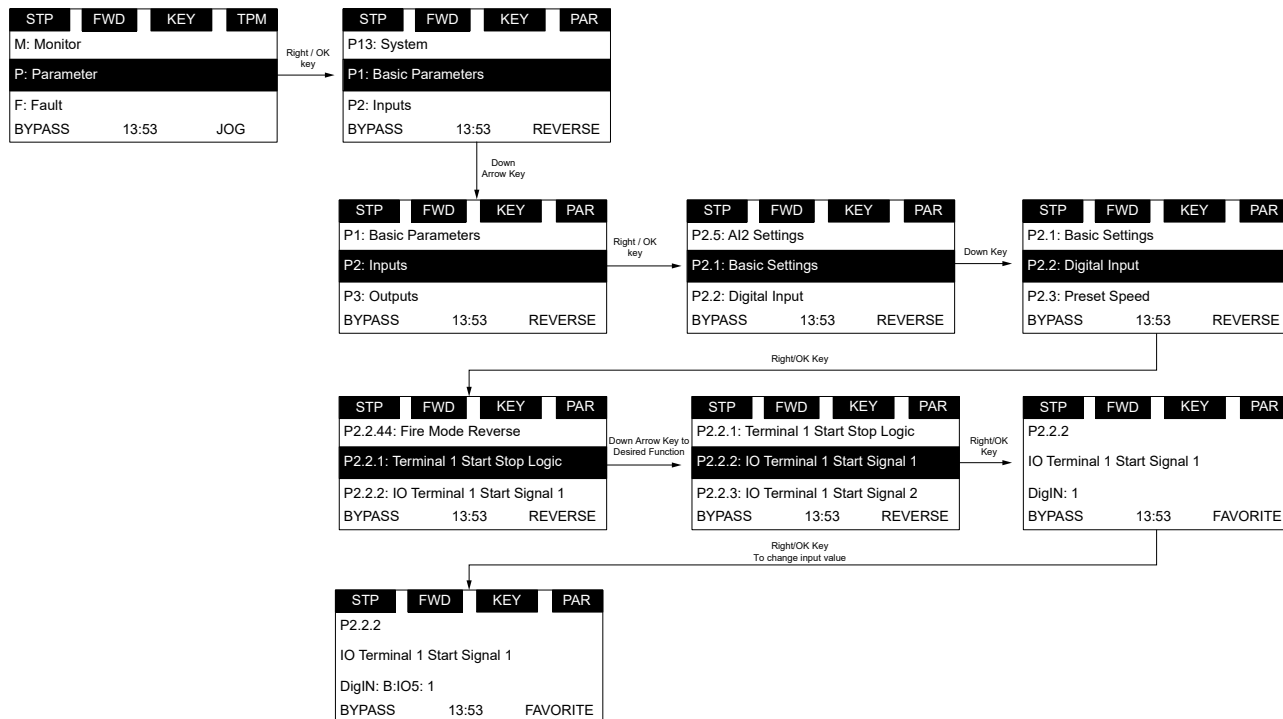

Figure 34. DH1 Input function







Eaton is dedicated to ensuring that reliable, efficient and safe power is available when it's needed most. With unparalleled knowledge of electrical power management across industries, experts at Eaton deliver customized, integrated solutions to solve our customers' most critical challenges.

Our focus is on delivering the right solution for the application. But, decision makers demand more than just innovative products. They turn to Eaton for an unwavering commitment to personal support that makes customer success a top priority. For more information, **visit [www.eaton.com/electrical](http://www.eaton.com/electrical)**.

**Eaton**  
1000 Eaton Boulevard  
Cleveland, OH 44122  
United States  
[Eaton.com](http://Eaton.com)

© 2018 Eaton  
All Rights Reserved  
Printed in USA  
Publication No. MN040007EN / Z14912  
August 2018

Eaton is a registered trademark.

All trademarks are property  
of their respective owners.

