

Dimensions VLT® HVAC Drive

In mm

A2 enclosures

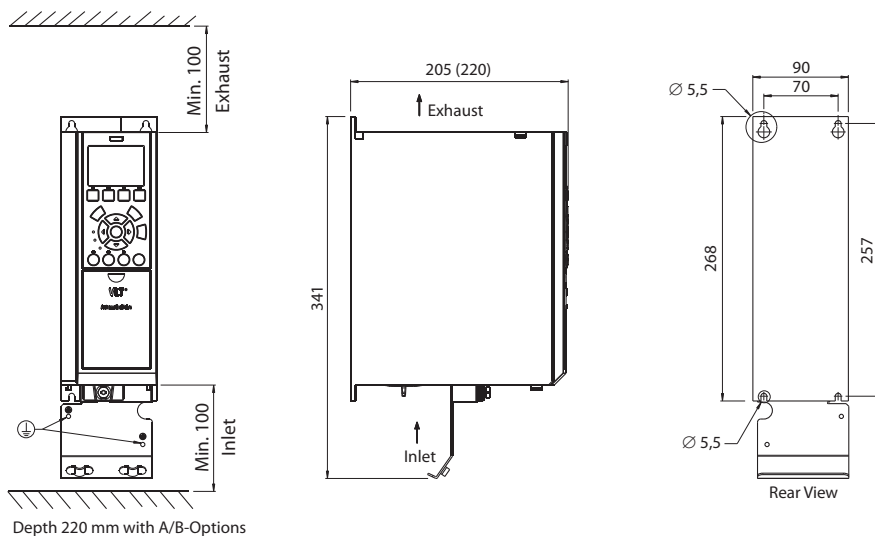

A2

A3 enclosures

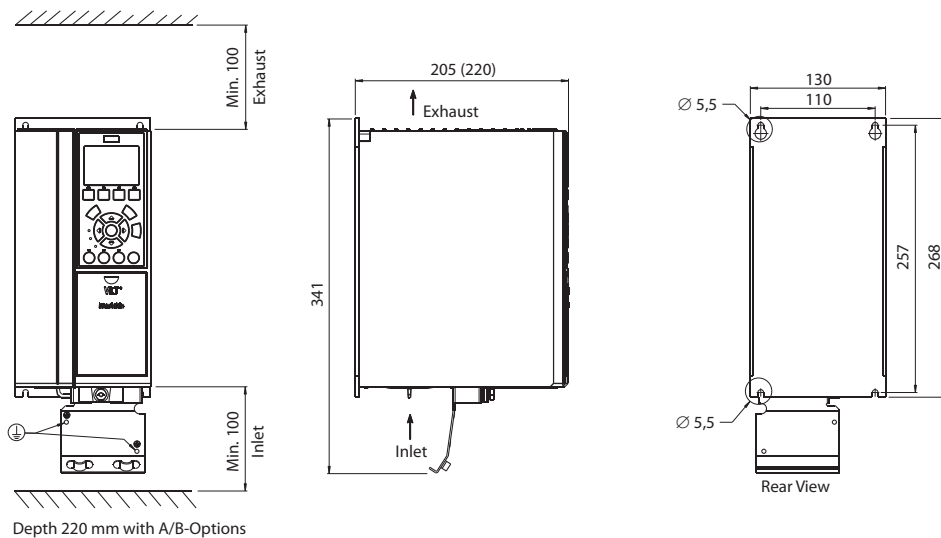

A3

A4 enclosures

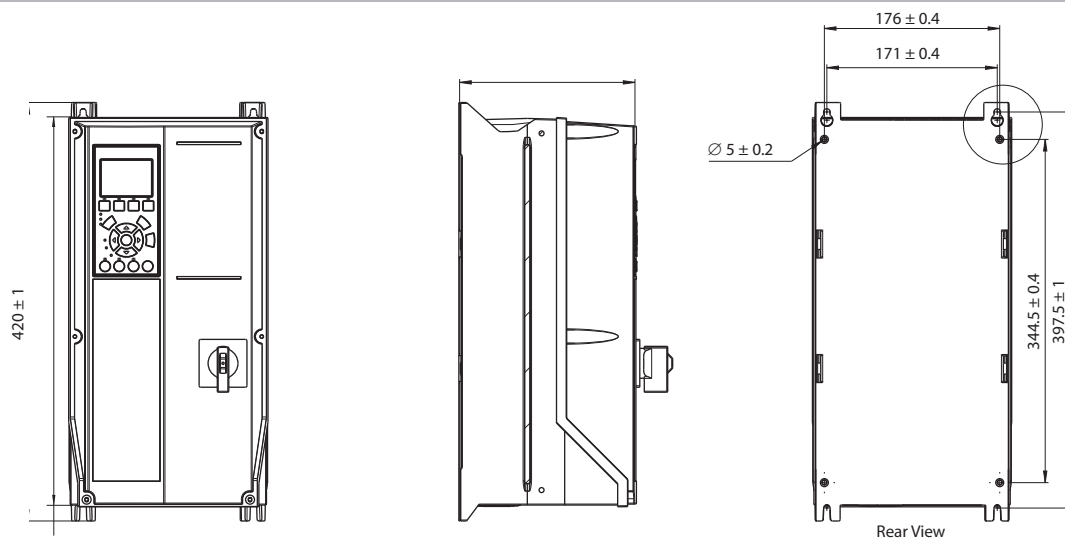

A4

Dimensions VLT® HVAC Drive

In mm

A5 enclosures

A5

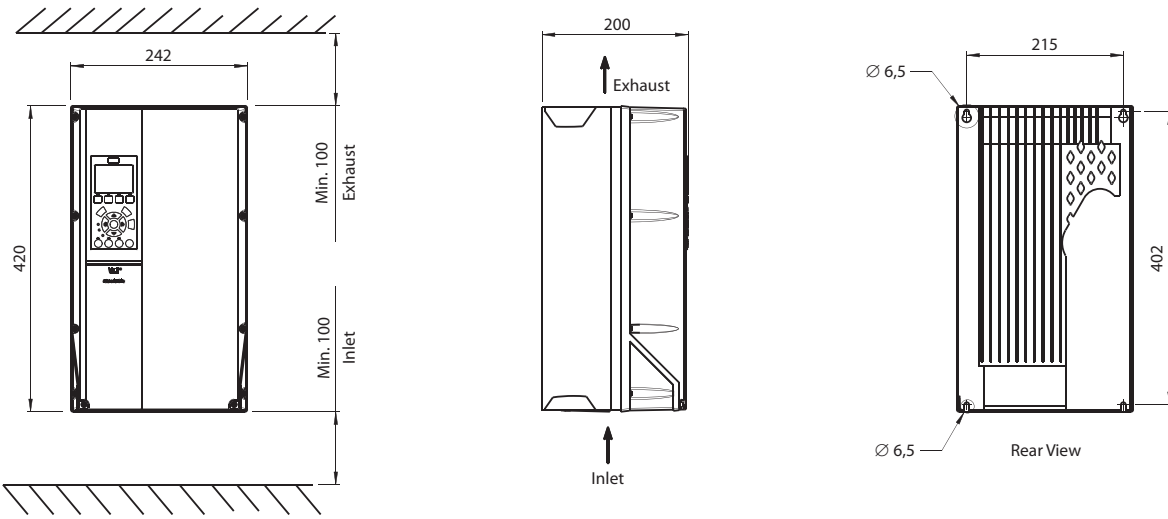

B1 enclosures

B1

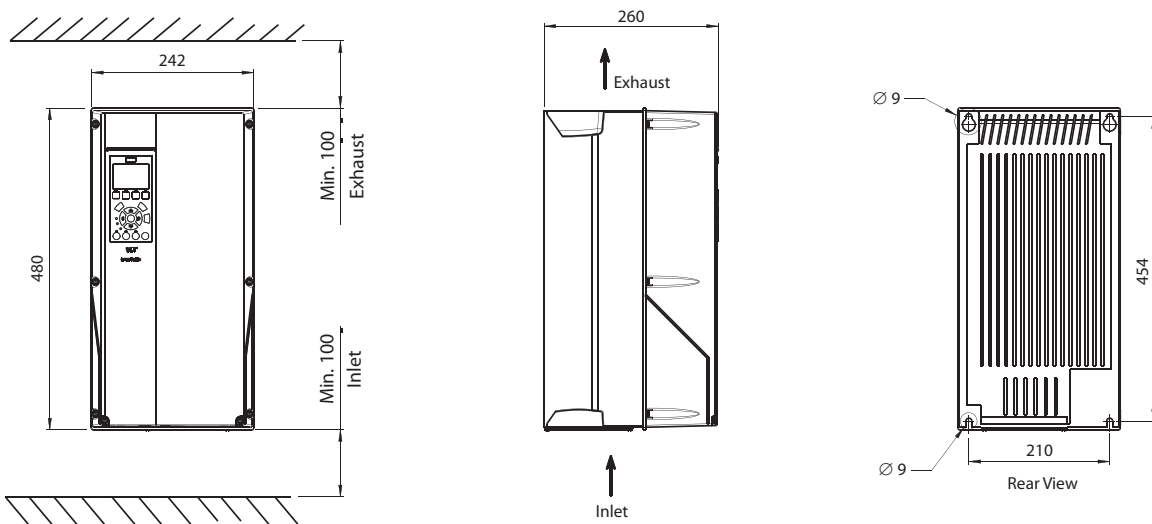

B2 enclosures

B2

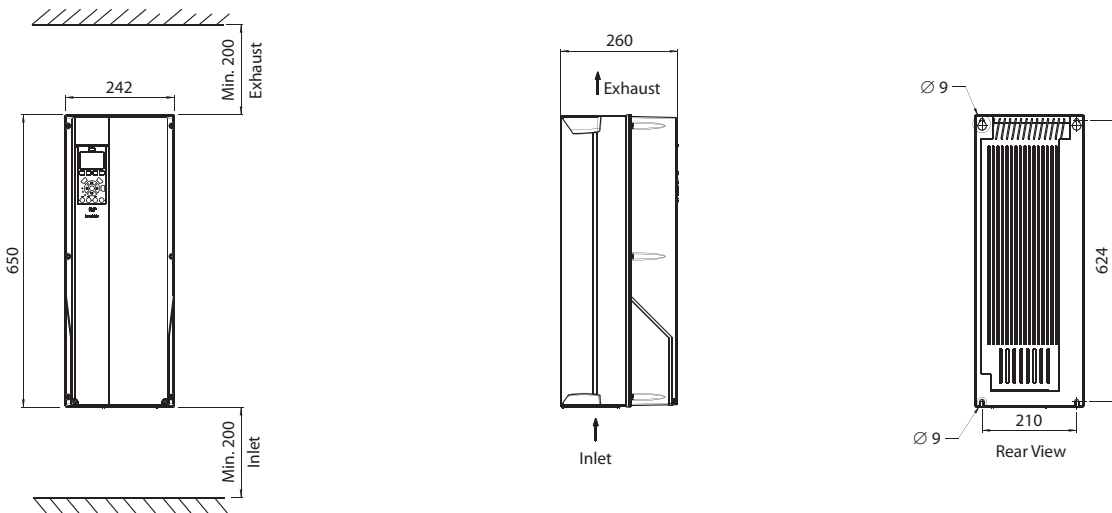

B3 enclosures

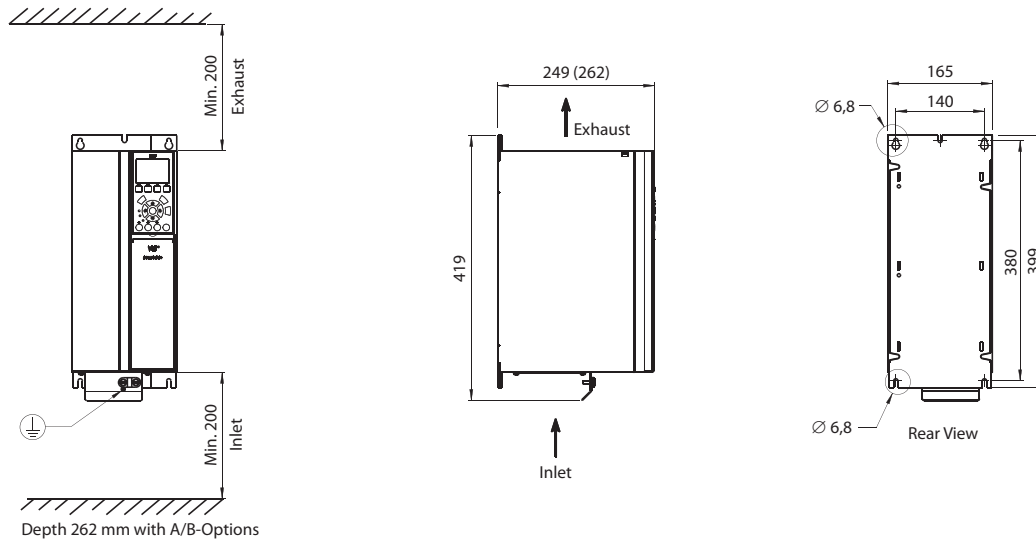

B3

B4 enclosures

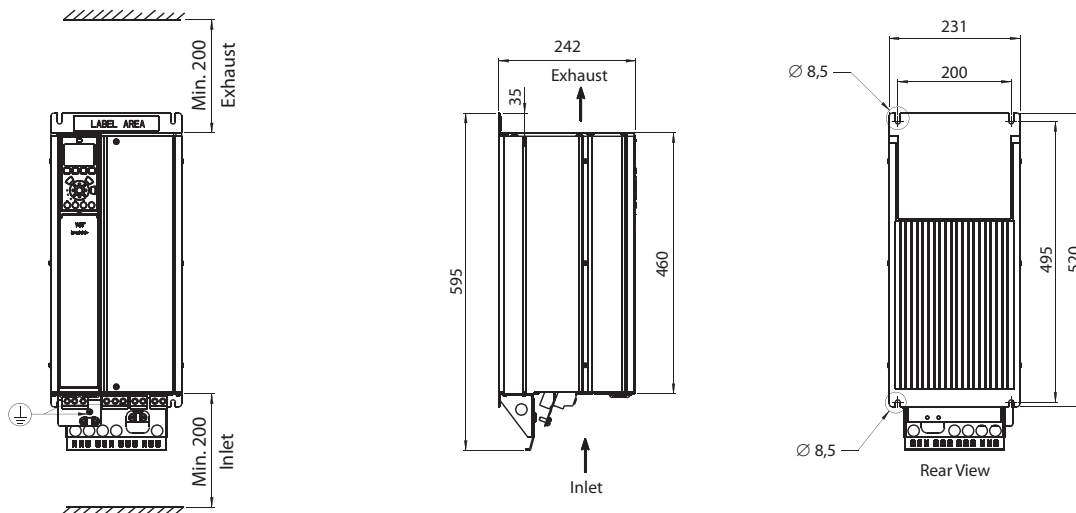

B4

C1 enclosures

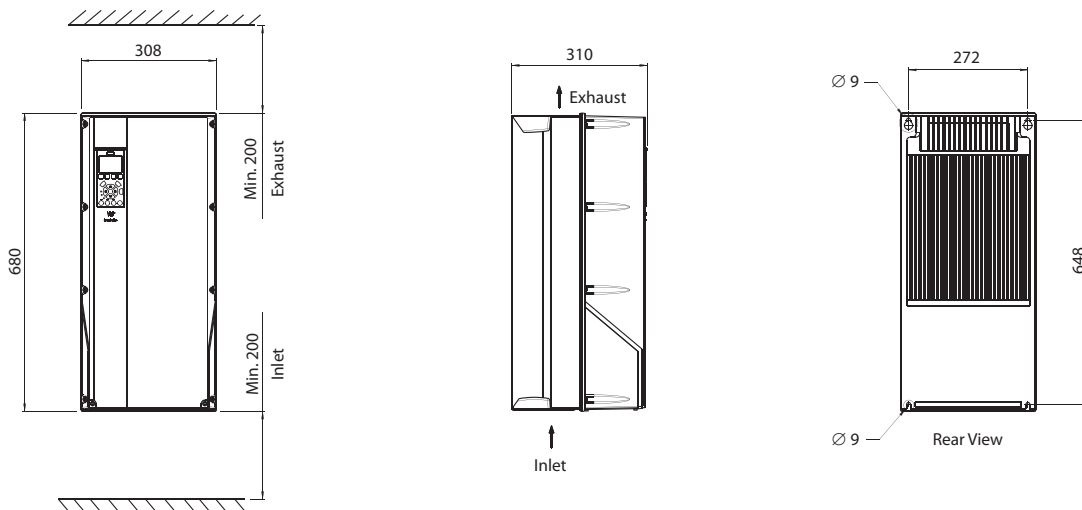

C1

Dimensions VLT® HVAC Drive

In mm

C2 enclosures

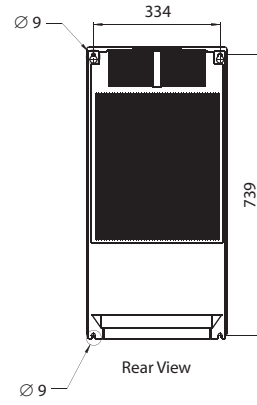
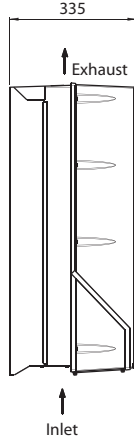
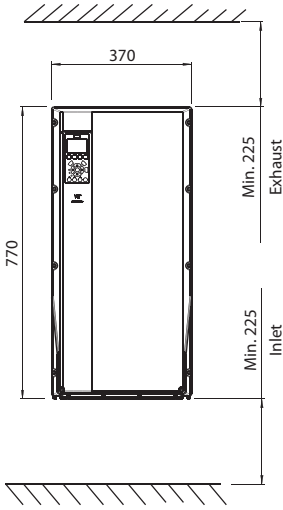

C3 enclosures

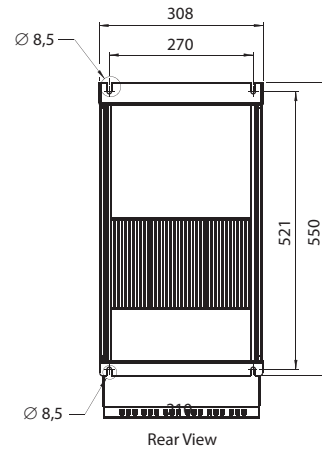
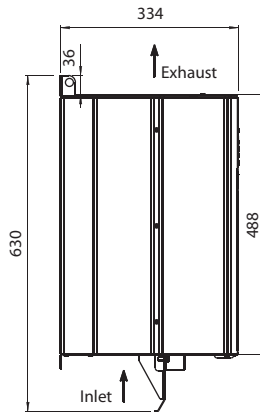
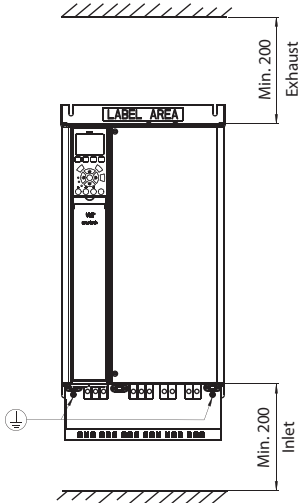

C4 enclosures

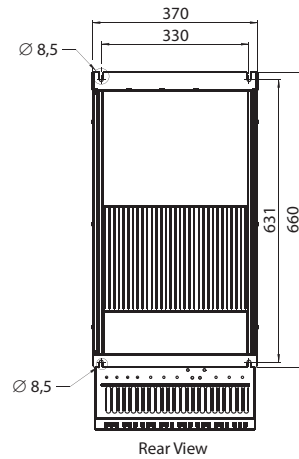
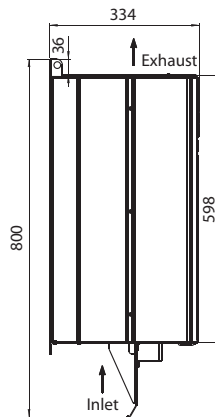
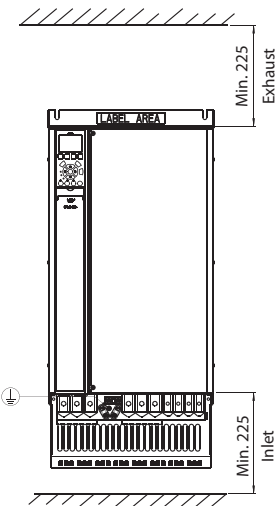

C2

C3

C4

D1 enclosures (floor- or cabinet mount)

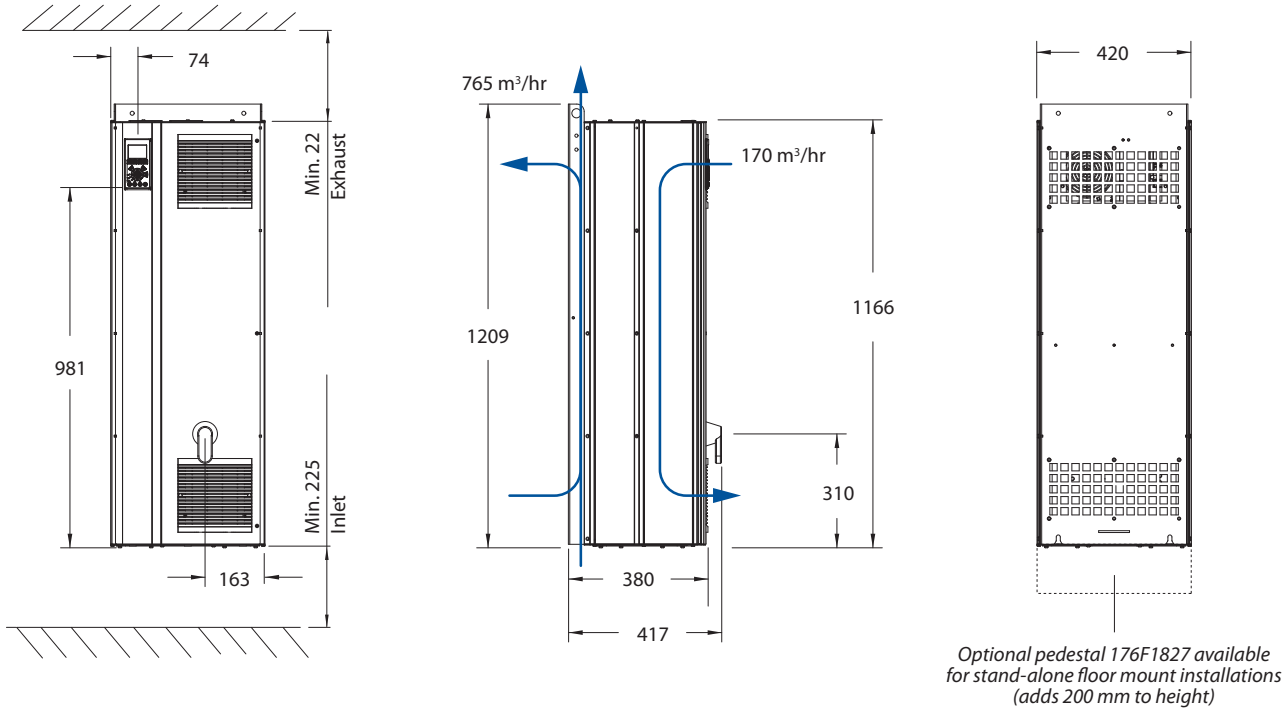

D1

D2 enclosures (floor- or cabinet mount)

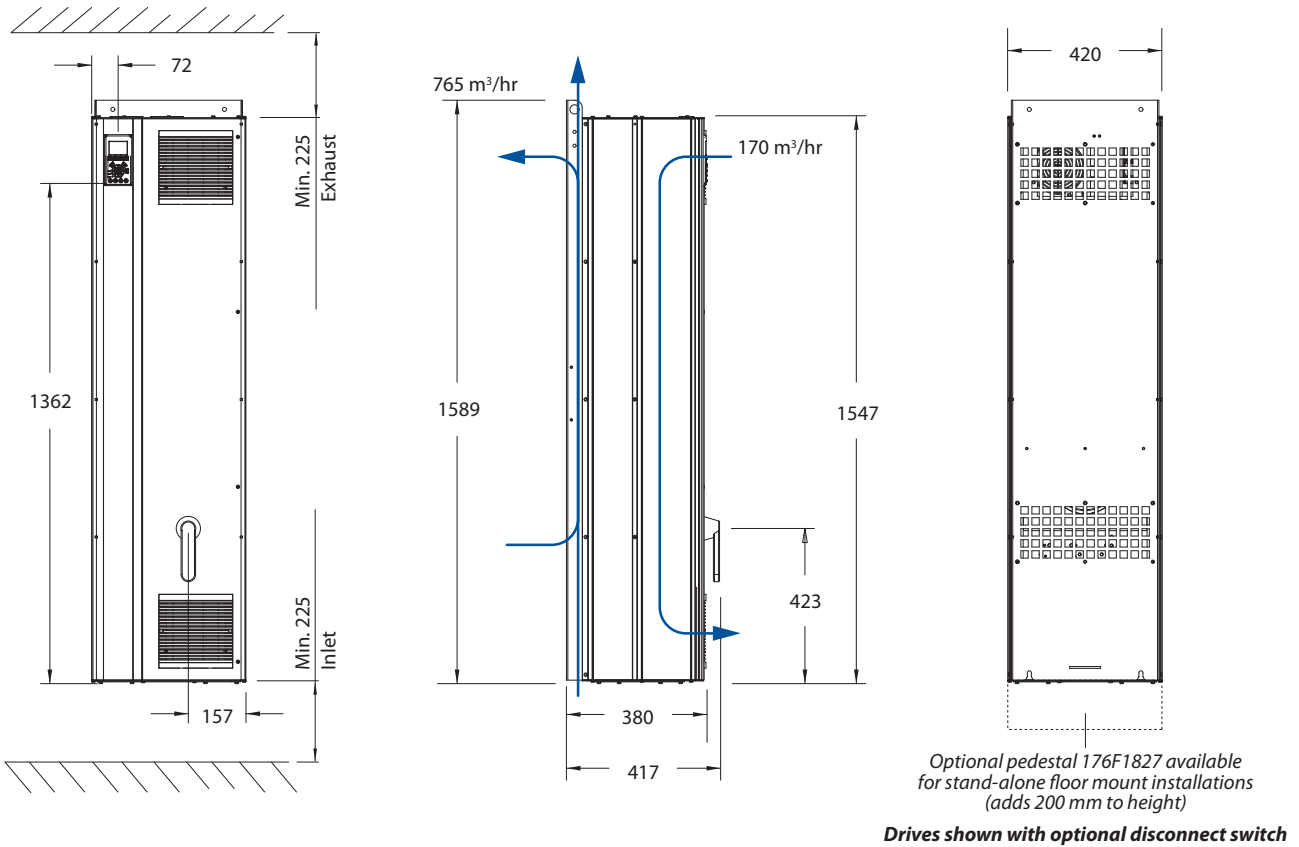

D2

Dimensions VLT® HVAC Drive

In mm

D3 enclosures (cabinet mount)

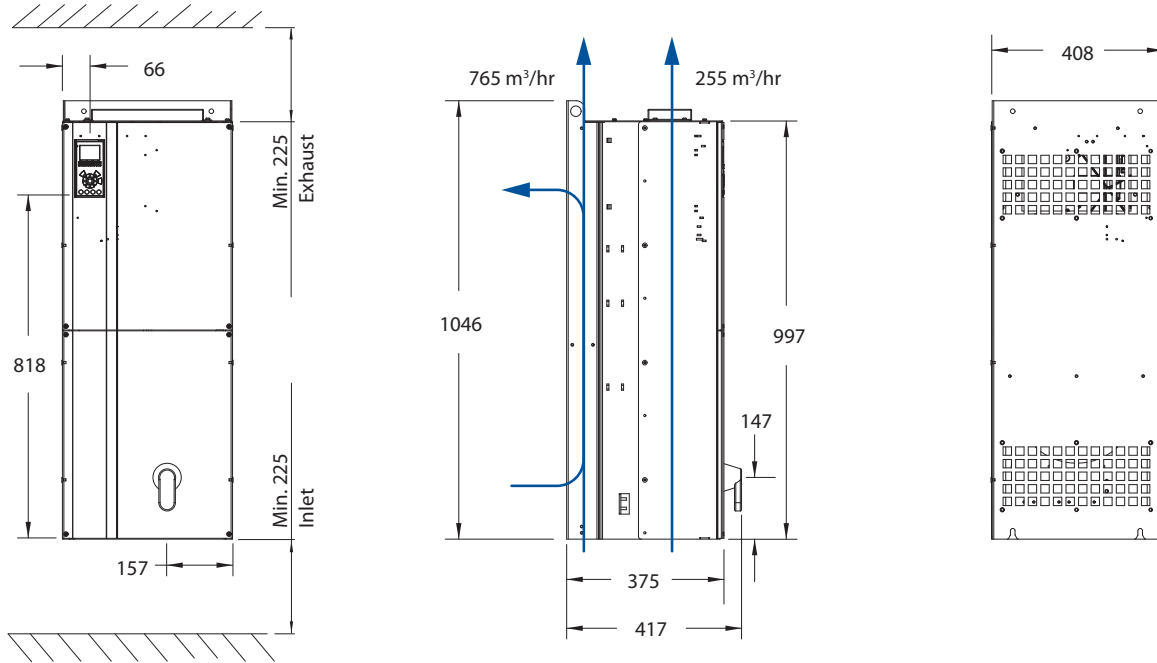

D4 enclosures (cabinet mount)

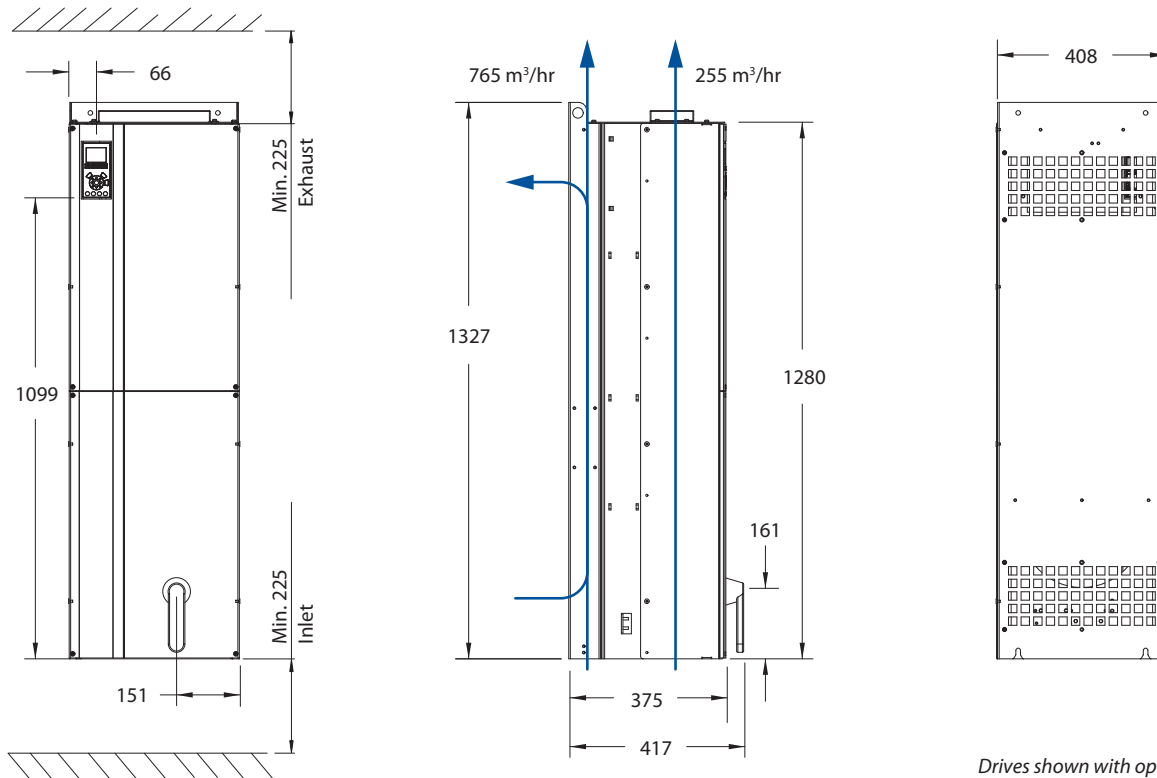

Drives shown with optional disconnect switch

D3

D4