

Installation guide

Thermostat Type KPU

060R9769

060R9769

Application

KPU thermostats are used for regulation and to ensure safety in refrigeration, freezing, air conditioning, ventilating and heating systems.

KPU thermostats are available with vapor charge or with adsorption charge.

All KPU thermostats are fitted with Single-Pole Double-Throw (SPDT) switches.

For large a.c. motors and for all d.c. motors, KPU is installed in the control circuit. For single phase ac motors, KPU is installed in the line voltage supply to the motor.

The standard KPU enclosure is rated NEMA 1.

NEMA 1 is obtained when the thermostat is mounted on a flat surface. When mounting KPU on a bracket, cover all unused holes.

Product Specification

Charge	Type	Code no.	Bulb type	Capillary tube length [in.]	Reset function	Regulating range [°F]	Differential Δt [°F]	Max. bulb temperature [°F]	Ambient temperature [°F]
Vapor	KPU 61	060L5201	A	80	auto.	-20 – 60	4 – 18 ²⁾	250	-40 – 122 (170 for max. 2 hours)
	KPU 61	060L5203	B	80	auto.	-20 – 60	4 – 18 ²⁾	250	
	KPU 61B	060L5204	B	80	man. (min.) ¹⁾	-20 – 60	5 (fixed) ²⁾	250	
	KPU 61B	060L5205	B	200	man. (min.) ¹⁾	-20 – 60	5 (fixed) ²⁾	250	
	KPU 61	060L5210	B	80	auto.	-20 – 60	4 – 18 ²⁾	250	
	KPU 62	060L5206	C1	0	auto.	-20 – 60	4 – 18 ²⁾	250	
	KPU 63	060L5213	A	80	auto.	-60 – 15	10 – 25 ²⁾	250	
	KPU 63	060L5214	B	80	auto.	-60 – 15	10 – 25 ²⁾	250	
	KPU 68	060L5215	C1	0	auto.	25 – 95	5 – 22 ²⁾	250	
Adsorption	KPU 69	060L5217	B	80	auto.	25 – 95	5 – 22 ²⁾	250	
	KPU 62	060L5207	C2	0	auto.	-20 – 60	4 – 15	175	
	KPU 73	060L5208	E3	80	auto.	-15 – 60	5 – 35	175	
	KPU 73	060L5209	E1	80	auto.	-15 – 60	15 – 45	175	
	KPU 73B	060L5211	E3	80	man. (min.) ¹⁾	-15 – 60	6 (fixed)	175	
	KPU 73	060L5212	D	80	auto.	-15 – 60	5 – 35	175	
	KPU 71	060L5218	E2	80	auto.	25 – 70	5 – 18	175	
	KPU 71B	060L5216	E2	80	man. (min.) ¹⁾	25 – 70	5 (fixed)	175	
	KPU 74	060L5219	E1	80	auto.	0 – 80	9 – 35	175	
	KPU 74B	060L5220	E1	80	man. (min.) ¹⁾	0 – 80	10 (fixed)	175	
KPU 75	060L5221	F	80	auto.	30 – 95	5 – 18	230		
KPU 77	060L5223	E3	80	auto.	60 – 140	6 – 18	265		

¹⁾ man. (min.): Manual reset after cut-out on falling temperature.

²⁾ The switch differential is dependent on range settings. Low range settings increases the differential.

High range settings decreases the differential. Use the graphs on page 3 to determine the correct differential setting.

Thermostat bulb types

A	B	C	D	E	F
straight capillary tube	remote air coil	air coil/room sensor	double contact remote coil	remote bulb	remote duct coil

Installation

Select an accessible location, where the thermostat will not be subject to damage. Mount the KPU on a bracket or on a completely flat surface. Mounting on an uneven surface may cause incorrect thermostat operation. For bracket mounting, use only the 10-32 x $\frac{3}{16}$ in. screws furnished with the thermostat. Other screws may interfere with the functioning of the thermostat. In no case can screws protrude more than $\frac{1}{8}$ in. into the thermostat. Use only the mounting holes provided. Do not make additional holes.



IMPORTANT:

For vapor charged thermostats, ensure that the bulb is installed in a colder location than the thermostat housing and capillary tube. This prevents charge migration from the bulb and ambient temperature will have no effect on regulation accuracy.

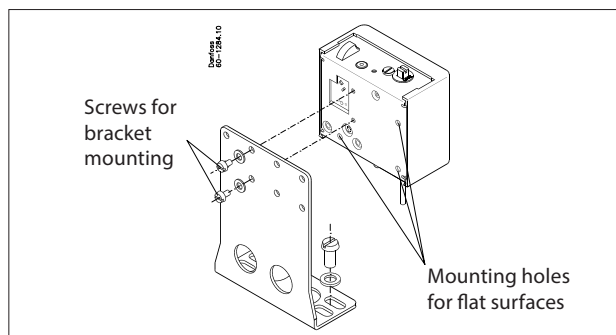

For adsorption charged thermostats, the bulb can be placed in a warmer or colder location than the thermostat housing and capillary tube.

General recommendations for capillary tube and bulb installation:

1. Protect the capillary tube from damage due to vibration.
 - a) When the thermostat unit is mounted directly on the compressor, the capillary tube must be secured to the compressor so that both vibrate together.
 - b) For mounting otherwise, form surplus capillary tube into a loose loop, and secure the length of capillary tube between the compressor and the loop to the compressor. Secure the length from the loop to the thermostat to the base on which the thermostat is mounted.
2. Leave a little slack in the capillary tube to help dampen vibration.
3. Avoid sharp bends and bending the capillary tube at the same point several times, as these actions can weaken the material and increase the likelihood of the tube cracking.
4. Form and locate the capillary tube away from sharp or abrasive objects that might damage it.
5. Never allow the capillary tube of a vapor charged thermostat to run alongside of a suction line in a wall entry.
6. Ensure minimal length of capillary tube exposed to temperature for KPU with straight capillary bulb type:
 - 16 in. for KPU thermostats with 80 in. capillary tube,
 - 22 in. for KPU thermostats with 200 in. capillary tube.

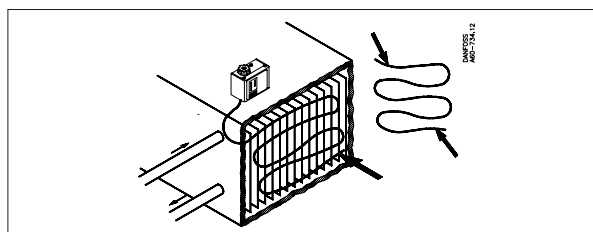

7. For thermostats with room sensor coils, make sure that placement allows free airflow around the coil and bulb. At the same time, ensure that the bulb is not exposed to drafts from doors, or to heat radiated from the evaporator surface. Make sure that the bulb does not come into contact with a wall surface. Never mount the thermostat directly on a cold wall. Instead, mount the unit on an insulating plate.



IMPORTANT:

Do not dent or deform the bulb of the thermostat, as doing so could damage the bulb and cause charge leakage.

Wiring

Electrical ratings according to UL regulations

120 V a.c.	24 FLA, 144 LRA - make only
240 V a.c.	24 FLA, 144 LRA - make only
240 V d.c.	12 W pilot duty

European electrical ratings according to EN 60947

AC1	AC3	AC15	LR	DC13
16 A	16 A	10 A	112 A	12 W
400 V				220 V



CAUTION:

To avoid the possibility of electric shock and damage to equipment, disconnect the power supply before any wiring connections are made. Never touch current conducting (LIVE) parts with your fingers or with tools.



NOTE:

All wiring should conform to the National Electrical Code and to applicable local regulations. Use only copper wire. Use only the terminal screws furnished in the terminal block. Do not exceed tightening torque of 20 inch pounds (2.3 Nm). Do not exceed the thermostat's specified electrical ratings.

The terminal block as well as grounding screw are accessible after dismantling the front cover.

Wiring Option A:

– Cut-Out on temperature fall

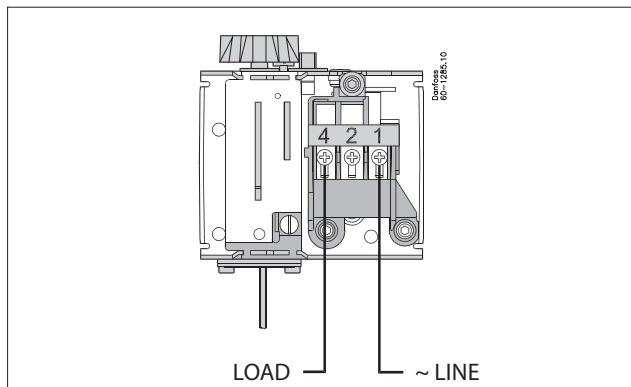

Wiring Option B:

– Cut-Out on temperature rise

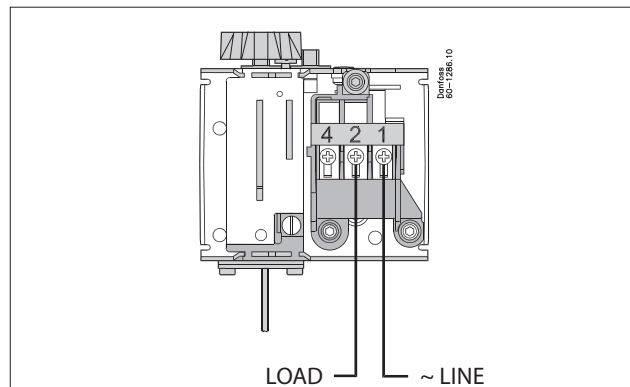

Wire dimensions: 10 AWG max.
Cable entry: $\frac{7}{8}$ in. cable entry for $\frac{1}{2}$ in. male pipe thread connection (conduit boss) or similar (Pg 13.5 or Pg 16) screwed cable entry.

Contact function test (Manual trip)

When the electrical leads are connected the contact function can be manually tested regardless of temperature conditions in the system.

The manual trip lever is located in the left side of the KPU. It must be operated with fingers only. Do not use screwdriver as it will damage the thermostat.

NOTE: While operating the manual trip on KPU switches with manual reset it is necessary to push the reset knob.

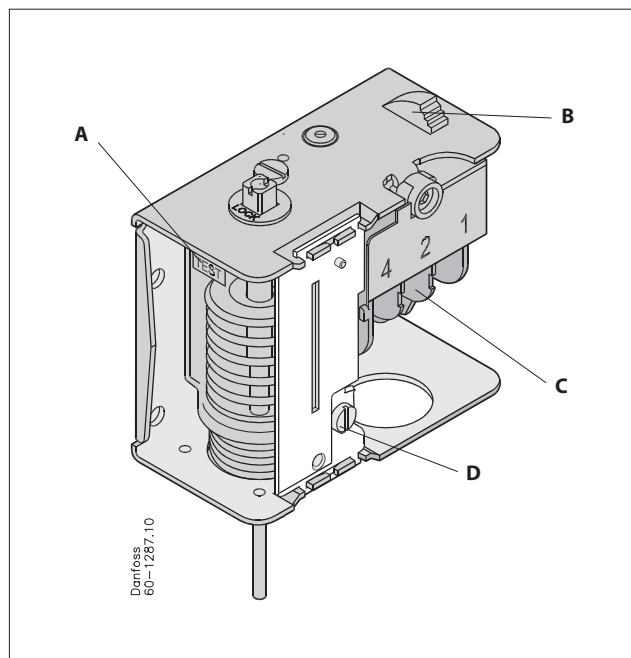

- A:** Manual trip. Push the lever. Use fingers only!
- B:** Manual reset button (only on versions sold with manual reset function)
- C:** Terminal block
- D:** Grounding screw

Determination of differential

For KPU thermostats with vapor charge and automatic reset, use the following graphs to determine the correct differential.

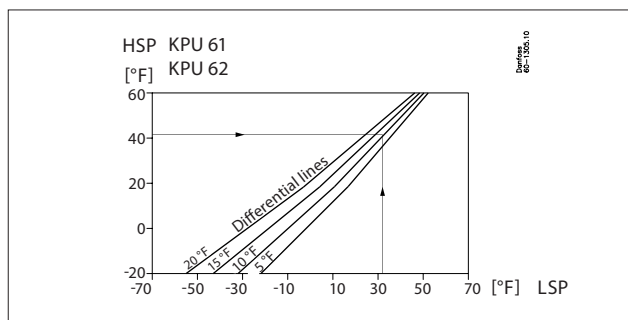

Example:
HSP = 45 °F DIFF (from graph):
LSP = 32 °F => 13 °F (value which has to be set on diff. scale)

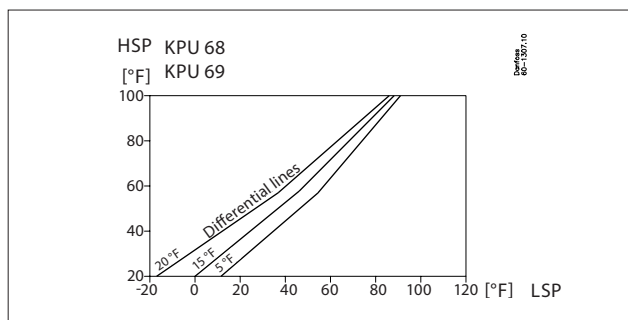
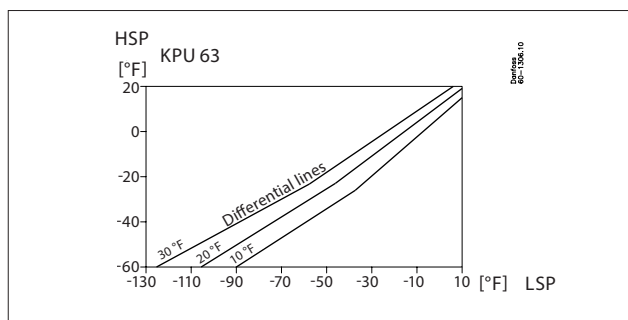

Adjustment



NOTE:

Adjust the thermostat to settings specified by the manufacturer of the controlled equipment. When checking thermostat operation, or operating the controlled equipment, do not exceed the manufacturer's temperature ratings for the controlled equipment or for any of its components. To avoid inaccurate thermostat operation, do not adjust the KPU's pointers beyond the highest or lowest indicator marks on the scale plate.

Before adjustment loosen the locking screw.

For setting use Universal Refrigeration Wrench or the setting knob, if available. Movement of the setting knob is limited by the locking screw, which allows only small corrections to the settings. Therefore, if the setting knob is to be used for adjustments, completely remove the locking screw. After adjustment, tighten the locking screw.

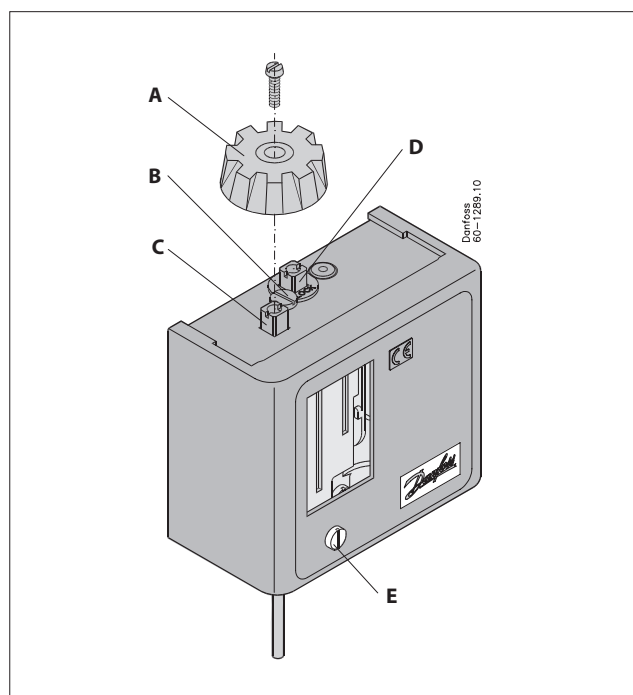

- A:** Setting knob
- B:** Locking screw
- C:** Range adjusting screw
- D:** Differential adjusting screw
- E:** Cover screw

Adjustment: thermostat with automatic reset

Scale plate directly indicates High Switching Point and Differential.

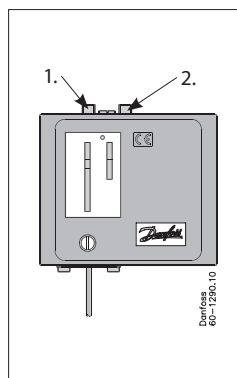

1. Set High Switching Point by adjusting range screw. Turn the screw clockwise to lower the set point.
2. Then set Differential by adjusting differential screw. Turn the screw clockwise to increase Differential.
3. Low Switching Point is equal to High Switching Point less Differential:
 $LOW = HIGH - DIFFERENTIAL$

Adjustment: thermostat with manual reset

Scale plate directly indicates Low Switching Point, which is Cut-Out. There is no pointer for Differential. Differential value is fixed and printed on the scale plate.

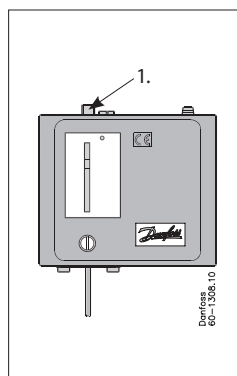

1. Set Cut-Out (Low Switching Point) by adjusting range screw. Turn the screw clockwise to lower the set point.
2. High Switching Point (Cut-In) equals Low Switching Point (Cut-Out) plus Differential:
 $CUT\ IN = CUT\ OUT + DIFFERENTIAL$



IMPORTANT:

The scale plate is only for reference and for more precise setting a temperature gauge should be used.



IMPORTANT:

After installing and adjusting the thermostat, check your settings by running the controlled equipment several times (at least three times) under normal operating conditions.

Manual switch

Available only on KPU 61 (060L5210) and KPU 62 (060L5207), the manual switch is a two-position switch used to shut down the refrigeration system. The two positions are:

1. AUTO: position for automatic operation.
2. STOP: contacts 1 and 2 are locked in the closed position.



CAUTION:

The manual switch only stops automatic operation, and can only be used for service on non-electrical parts. Interrupt mains power before servicing electrical parts.

