



Automation for a Changing World

# Delta Textile Vector Control Drive CT2000 Series



**DELTA**  
Smarter. Greener. Together.

The CT2000 Series is an industrial drive designed for textile and other critical environment applications that have a high density of dust, fiber, oil or other such substances. To prevent fiber or dust from clogging or entering the drive, the CT2000 offers a fanless design for flange mount installation which is suitable for an application environment that has an air cooling duct system. There is also a large fan design for wall mount installation that can fit all types of applications. The CT2000 provides ultimate application flexibility for the textile industry.



Applications: Spinning machines, roving machines, machine tool, ceramic, glass and other highly demanding industries.

## Features

- Fanless design with high efficiency heat sink to prevent fiber and dust from clogging or entering the drive. No more overheating problems (\*1)
- Flange mount installation to enhance system safety and stability and provide excellent heat dissipation performance (\*1)
- Supports external fan connection (\*1)
- Wall mount installation model with a large fan (\*2)
- Deceleration Energy Backup (DEb) function for smooth motor deceleration control
- Supports both asynchronous and synchronous motors
- Common DC bus design
- Enhanced drive durability using Printed Circuit Board (PCB) coating standard IEC 60721-3-3 CLASS 3C2
- Built-in 10K steps PLC programming capability and RS-485 with MODBUS communication for master station so there is no need for an additional host controller and communication module in the system. Constructs a simple network with high performance and effective cost.
- Optional communication cards are available upon request

\*1: For model names ending with code A or B

\*2: For model names ending with code C

## Deceleration Energy Backup (DEB)

The CT2000 Series features a Decelerate Energy Backup (DEB) function to prevent thread or yarn breaking when a sudden power outage or abnormal operation interruption occurs. It uses the regenerative energy that is produced during braking to facilitate the motor deceleration process. It also supports a common DC bus connection allowing multiple drives to control multiple motors decelerating to a stop smoothly and synchronously at the same speed ratio which is a perfect solution for spinning machines and other applications that require synchronous deceleration control of motors via DC bus.

# Standard Model

Power Range 460 V 11~90 kW

460 V (kW)	11	15	18.5	22	30	37	45	55	75	90
460 V (HP)	15	20	25	30	40	50	60	75	100	125
Frame (Flange Mount)	B			C			D			
Frame (Wall Mount)	B			C			D			

## Flange Mount

Flange mount installation for the fanless model. This design avoids fiber or dust clumping in the fan or entering the drive and prevents overheating problems. This model is suitable for an application environment that has sufficient space for an airway for the drive. (See the picture on the right)

(Available for models with names ending in A or B)

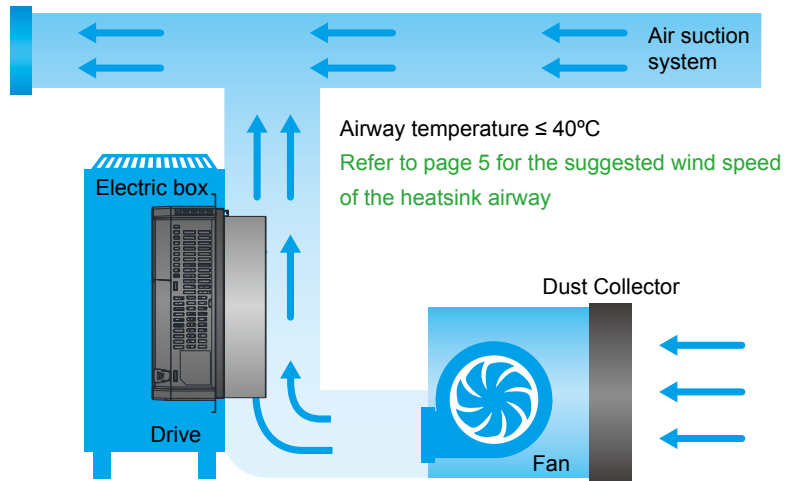

## Wall Mount

Larger fan design for the wall mount model to fulfill other textile application needs.

(Larger fan is available for models with names ending in C)

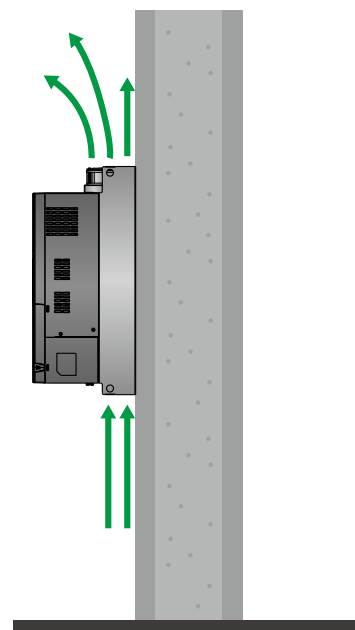

# Modular Design

- Various accessories options, such as I/O extension cards, encoder feedback cards, communication cards, hot pluggable LCD keypad, removable terminals and removable fans.

## ▶ PG Card

EMC-PG010 / EMC-PG020



EMC-PG01U / EMC-PG02U



EMC-PG01L / EMC-PG02L



EMC-PG01R



## ▶ I/O Extension Card

EMC-D611A



EMC-D42A



## ▶ 24V Power Shift Card

EMC-BPS01



## ▶ Relay Extension Card

EMC-R6AA



## ▶ Communication Card

CMC-PD01



CMC-DN01



CMC-MOD01  
CMC-EIP01



EMC-COP01



\* ▶ : Optional accessories available upon purchase

## ■ Removable terminal blocks

Safe and easy to install

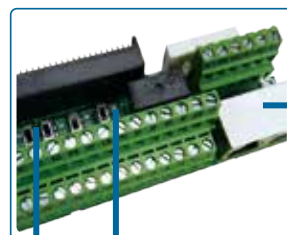

### Analog I/O switches



### RS-485 communication

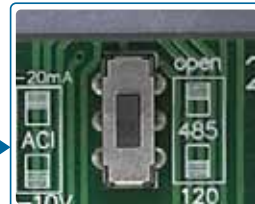

### RJ45 serial communication port





# Specifications

## Environment for Operation, Storage and Transportation

DO NOT expose the AC motor drive to harsh environments, such as with dust, direct sunlight, corrosive/flammable gasses, humidity, liquid or vibrations. The salts in the air must be less than 0.01mg/cm<sup>2</sup> per year.

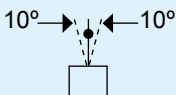
Environment	Installation location	IEC60364-1/IEC60664-1 Pollution degree 2, Indoor use only		
	Surrounding Temperature	Storage	-25°C ~ +70°C	
		Transportation	-25°C ~ +70°C	
				Only allowed for non-condensation, non-frozen, non-conductive pollution environment.
	Rated Humidity	Operation	Max. 95%	
		Storage/Transportation	Max. 95%	
				Only allowed for non-condensation, non-frozen, non-conductive pollution environment.
	Air Pressure	Operation/Storage	86 to 106 kPa	
		Transportation	70 to 106 kPa	
	Pollution Level	IEC60721-3-3		
Operation		Class 3C2; Class 3S2		
Storage		Class 1C2; Class 1S2		
Transportation		Class 2C2; Class 2S2		
			Only allowed for non-condensation, non-frozen, non-conductive pollution environment.	
Altitude	Operation	If AC motor drive is installed at an altitude 0~1000m, follow normal operation restrictions.If it is installed at altitude 1000~3000m, decrease 1% of rated current or lower 0.5°C of temperature for every 100m increase in altitude. Maximum altitude for Corner Grounded TN system is 2000m; for application higher than 2000m, please contact Delta for more details.		
Package Drop	Storage	ISTA procedure 1A (according to weight) IEC60068-2-31		
	Transportation			
Vibration	1.0mm, peak to peak value range from 2Hz to 13.2Hz; 0.7G~1.0G range from 13.2Hz to 55Hz; 1.0G range from 55Hz to 512Hz. Comply with IEC 60068-2-6			
Impact	IEC/EN 60068-2-27			
Operation Position	Max. allowed offset angle ±10° (under normal installation position)			

## Operation Temperature and Protection Level

Model	Frame	Top cover	Conduit Box	Protection Level	Operation Temperature
VFD □□□ CT43 □□□□□	B, C	Top cover removed	Standard conduit box	IP20/UL Open Type	Flange mount models: Drive body: -10~50 °C Heatsink side: -10~40 °C
	D	N/A	No conduit box	IP00 IP20/UL Open Type  Protection degree for the circled area is IP00; other areas are IP20.	

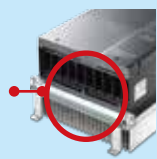

# Product Specifications

Frame Size			B			C			D			
Model VFD □□□□CT43 □□□□			110	150	185	220	300	370	450	550	750*	900*
Max. Applicable Motor Output (kW)			11	15	18.5	22	30	37	45	55	75	90
Max. Applicable Motor Output (HP)			15	20	25	30	40	50	60	75	100	125
Output Rating	Heavy Duty	Rated Output Capacity (kVA)	14	18	24	29	34	45	55	69	84	114
		Rated Output Current (A)	17	23	30	36	43	57	69	86	105	143
		Carrier Frequency (kHz)	2~6 kHz									
	Normal Duty	Rate Output Capacity (kVA)	18	24	29	36	45	57	73	88	115	143
		Rated Output Current (A)	24	32	38	45	60	73	91	110	144	180
Carrier Frequency (kHz)		2~15 kHz			2~10 kHz					2~9 kHz		
Input Rating	Input Current (A) Heavy Duty		19	25	33	38	45	60	70	96	108	149
	Input Current (A) Normal Duty		25	33	40	50	62	79	91	110	144	180
	Rated Voltage/Frequency		3-phase AC 380V ~ 480V (-15% ~ +10%), 50/60 Hz									
	Operating Voltage Range		323~528 Vac									
	Frequency Tolerance		47~63 Hz									
Cooling method			Flange-mounted model uses natural cooling, it is suitable for air cooling and use with heat sink; Wall-mounted model uses fan cooling									
Wind Speed at Heatsink Airway	Wind Speed at Carrier Frequency 2kHz (m/s)		3.5			3.5		7	3.5	4.5	6	8.5
	Wind Speed at Default Carrier Frequency (m/s)		3.5	6.5	8.5	3.5	7.0	9.5	5.5	6	8.5	9.5
Braking Chopper			Frame B to C (built-in); Frame D (optional)									
DC Reactor			Frame B to C (optional); Frame D (built-in)									
EMC Filter			Optional									

\*Only for drives with model names ending in the letter A

Control Characteristics	Control Method	1: V/F, 2: SVC, 3: VF+PG, 4: FOC+PG, 5: TQC+PG
	Starting Torque	Reach up to 150% or above at 0.5Hz. Under FOC+PG mode, starting torque can reach 150% at 0Hz.
	V/F Curve	4 point adjustable V/F curve and square curve
	Speed Response Ability	5Hz (vector control can reach up to 40Hz)
	Torque Limit	Light duty 130%, Heavy duty 175% torque current.
	Torque Accuracy at TQC Mode	±5%
	Max. Output Frequency (Hz)	Light duty: 0.01 ~ 599.00Hz; Heavy duty: 0.00 ~ 300.00Hz
	Frequency Output Accuracy	Digital command: ±0.01%,-10~+40°C · Analog command: ±0.1%, 25±10°C
	Output Frequency Resolution	Digital command: 0.01Hz · Analog command: 0.03*max. output frequency / 60 Hz (±11 bit)
	Overload Tolerance	Light duty: 120% of rated current for 1 minute per every 5 minutes Heavy duty: 150% of rated current for 1 minute per every 5 minutes
	Frequency Setting Signal	+10V~-10 · 0~+10V · 4~20mA · 0~20mA · Pulse input
	Accel./decel. Time	0.00~600.00/0.0~6000.0 seconds
Main control function	Torque control, Droop control, Speed/torque control switching, Feed forward control, Zero-servo control, Momentary power loss ride thru, Speed search, Over-torque detection, Torque limit, 17-step speed (max), Accel/decel time switch, S-curve accel/decel, 3-wire sequence, Auto-Tuning (rotational, stationary), Dwell, Cooling fan on/off switch, Slip compensation, Torque compensation, JOG frequency, Frequency upper/lower limit settings, DC injection braking at start/stop, High slip braking, PID control (with sleep function), Energy saving control, MODBUS communication (RS-485 RJ45, max. 115.2 kbps), Fault restart, Parameter copy	
Fan Control	Version B: no fan; Model VFD185CT43 and above: PWM control; Model VFD150CT43 and below: ON/OFF switch	
Protection Characteristics	Motor Protection	Electronic thermal relay protection
	Over-current Protection	Over-current protection for 200% rated current current clamp <sup>†</sup> Light duty: 130~140% <sub>Δ</sub> ; <sup>†</sup> Heavy duty: 180~185% <sub>Δ</sub>
	Over-voltage Protection	Drive operation stops when DC bus voltage exceeds 820V
	Over-temperature Protection	Built-in temperature sensor
	Stall Prevention	Stall prevention during acceleration, deceleration and in operation
	Restart After Instantaneous Power Failure	Up to 20 seconds (parameter setting)
Grounding Leakage Current Protection	Leakage current is higher than 50% of rated current of the AC motor drive	
Certifications		GB/T12668-2  

# Wiring

## Frame B ~ C

Input: 3-phase power

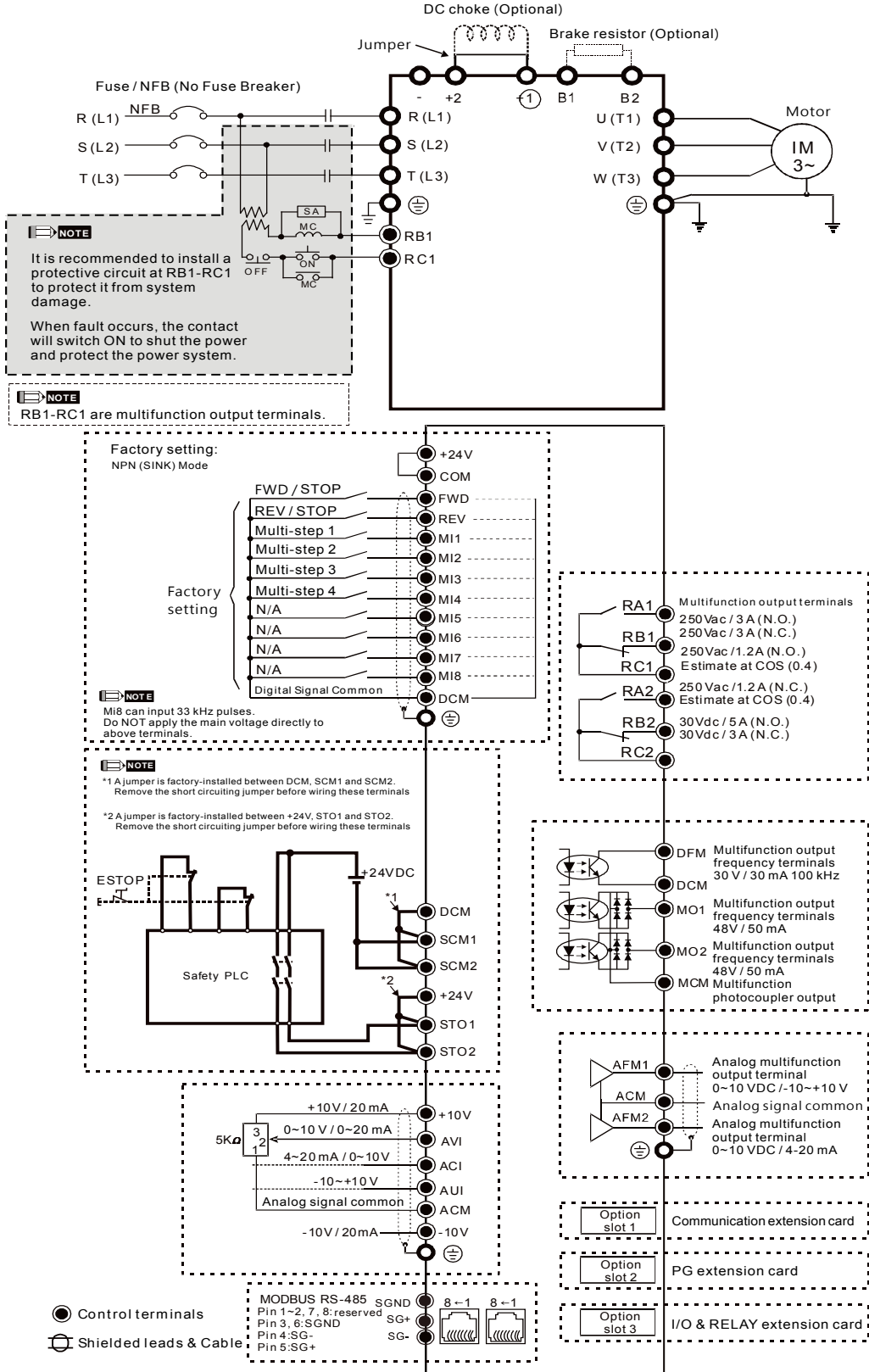

# Frame D

Input: 3-phase power

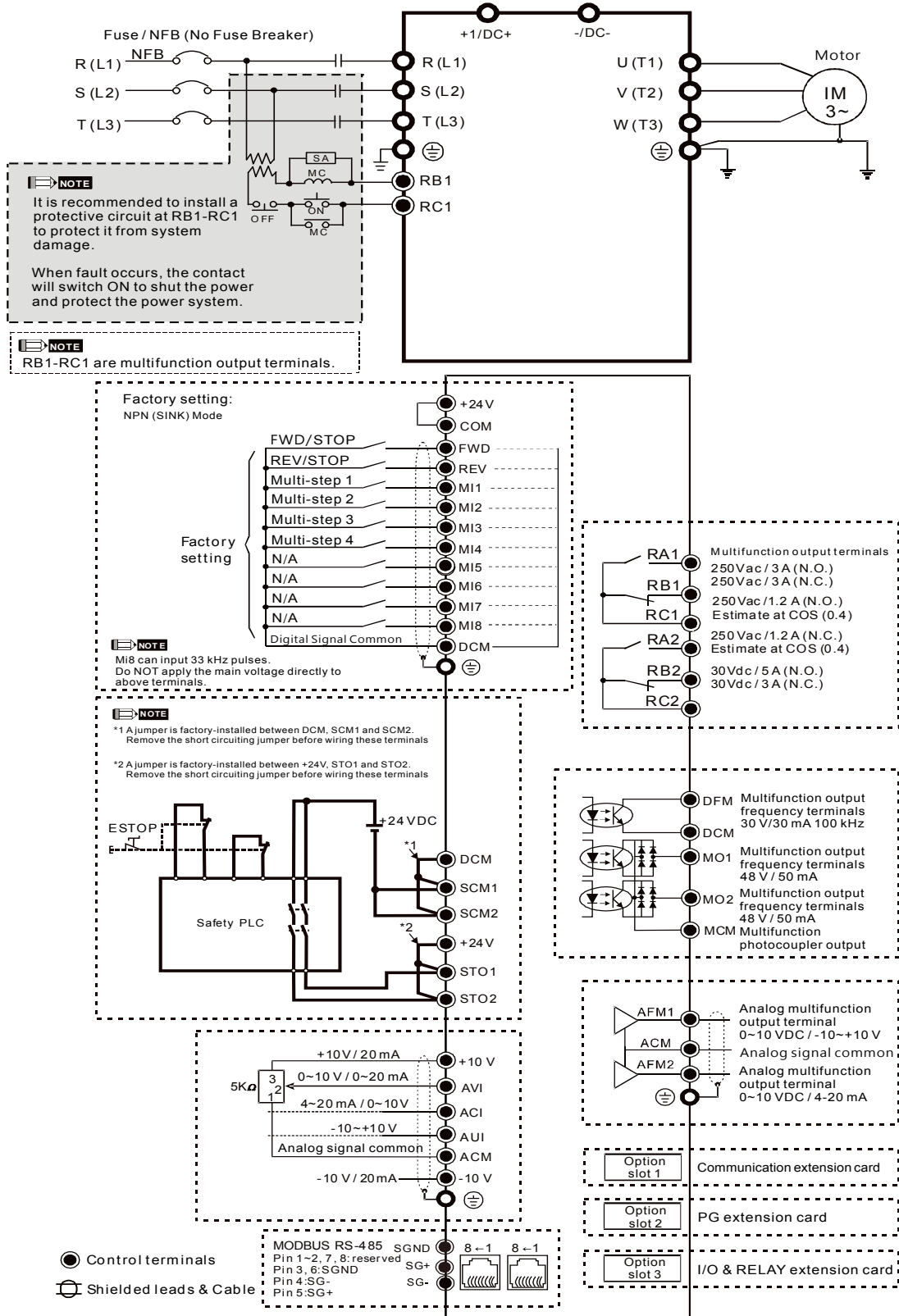



# Dimensions

## ■ Frame B (Flange mount)

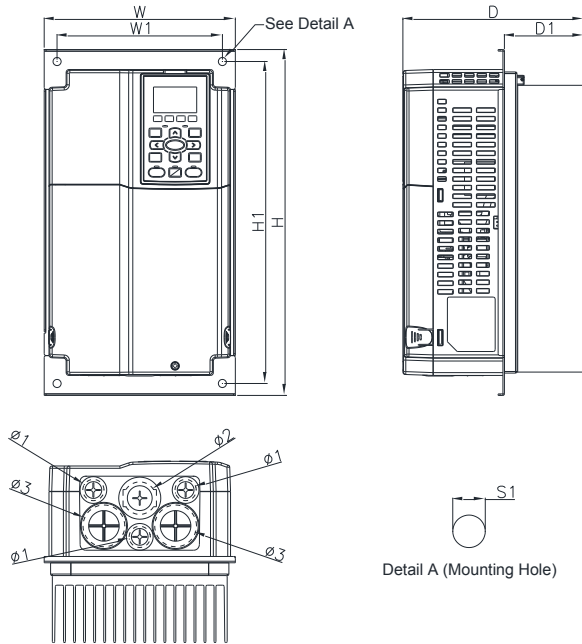

### MODEL

VFD110CT43F00B  
 VFD150CT43F00B  
 VFD185CT43F00B

Unit: mm[inch]

Frame		W	W1	H	H1	D	D1	S1	$\phi 1$	$\phi 2$	$\phi 3$
B	mm	200.0	173.0	361.8	336.8	189.4	83.2	8.5	22.2	34.0	43.8
	inch	7.87	6.81	14.24	13.26	7.46	3.28	0.33	0.87	1.34	1.72

## ■ Frame B (Wall mount)

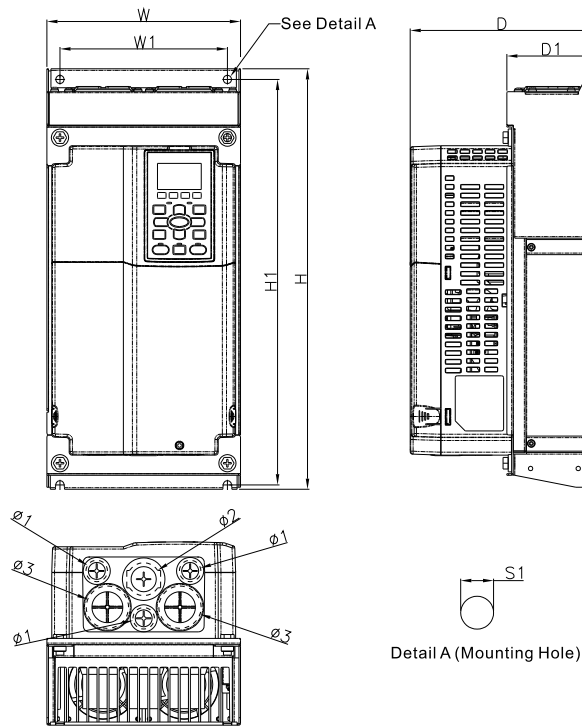

### MODEL

VFD110CT43A21C  
 VFD150CT43A21C  
 VFD185CT43A21C

Unit: mm[inch]

Frame		W	W1	H	H1	D	D1	S1	$\phi 1$	$\phi 2$	$\phi 3$
B	mm	200.0	173.0	435.0	419.4	189.4	89.8	8.5	22.2	34.0	43.8
	inch	7.87	6.81	17.13	16.51	7.46	3.54	0.33	0.87	1.34	1.72

■ Frame C (Flange mount)

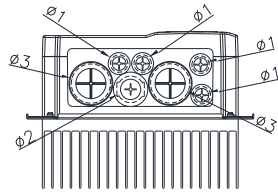
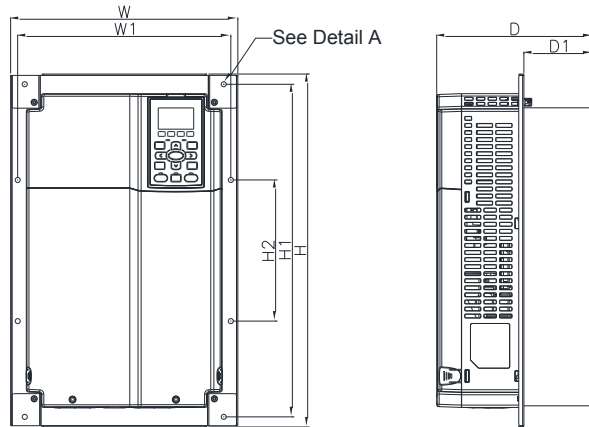

Detail A (Mounting Hole)

**MODEL**

VFD220CT43F00B  
VFD300CT43F00B  
VFD370CT43F00B

Unit: mm[inch]

Frame		W	W1	H	H1	H2	D	D1	S1	$\phi 1$	$\phi 2$	$\phi 3$
C	mm	290.0	272.0	450.0	424.0	180.0	199.5	88.2	6.5	22.2	34.0	50.0
	inch	11.42	10.71	17.72	16.69	7.09	7.86	3.47	0.26	0.87	1.34	1.97

■ Frame C (Wall mount)

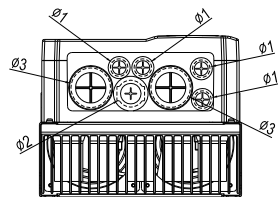
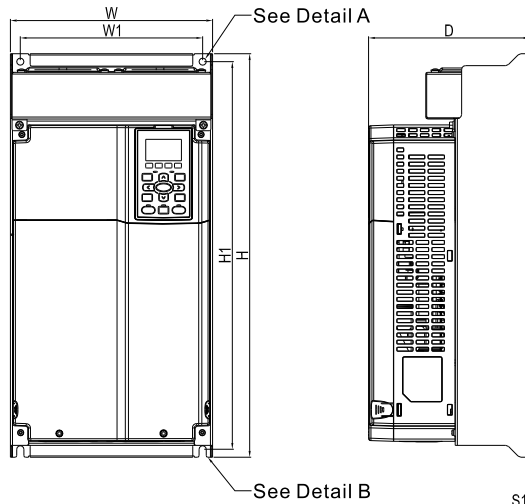

Detail A (Mounting Hole)



Detail B (Mounting Hole)

**MODEL**

VFD220CT43A21C  
VFD300CT43A21C  
VFD370CT43A21C

Unit: mm[inch]

Frame		W	W1	H	H1	D	S1	$\phi 1$	$\phi 2$	$\phi 3$
C	mm	256.0	231.0	510.0	490.0	204.0	9.0	22.2	34.0	50.0
	inch	10.08	9.09	20.08	19.29	8.03	0.35	0.87	1.34	1.97

■ Frame D (Flange mount)

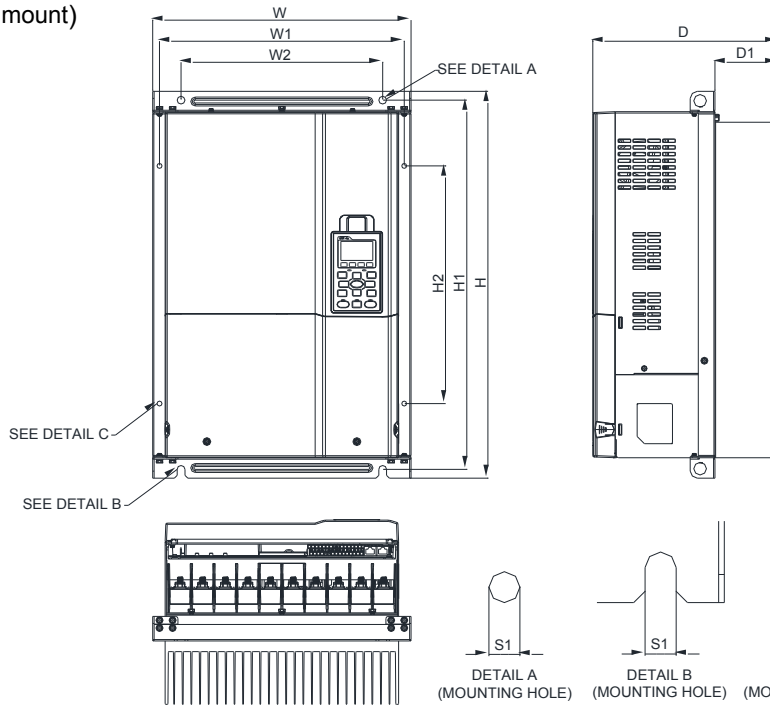

**MODEL**

VFD450CT43F00B  
 VFD550CT43F00B  
 VFD750CT43F00A6  
 VFD900CT43F00A8

Unit: mm[inch]

Frame		W	W1	W2	H	H1	H2	D	D1	S1	S2
D	mm	365.2	346.0	285.0	550.0	525.0	338.0	262.8	90.0	11.0	7.0
	inch	13.38	13.62	11.22	21.65	20.67	13.31	10.35	3.54	0.43	0.28

■ Frame D (Wall mount)

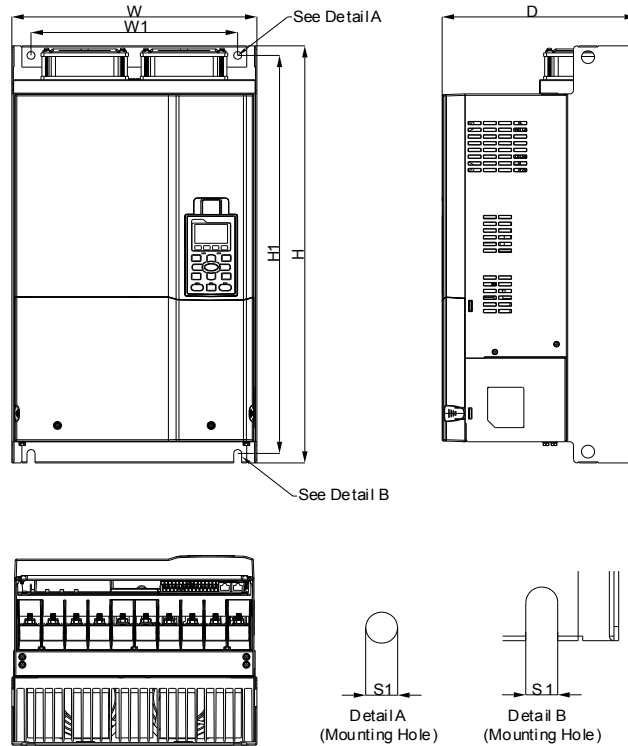

**MODEL**

VFD450CT43A00C  
 VFD550CT43A00C

Unit: mm[inch]

Frame		W	W1	H	H1	D	S1
D	mm	338.0	285.0	590.0	563.0	268.0	11.0
	inch	13.31	11.22	23.22	22.17	10.55	0.43

# Accessories

## EMC-PG01L / EMC-PG02L

		Terminals	Description
 <p>Set by Pr.10-00 ~ 10-02</p>	PG1	VP	Output voltage for power: +5V/+12V ± 5% (use FSW3 to switch +5V/+12V) Max. output current: 200mA
		DCM	Common for power and signal
		A1, /A1, /B1, /B1, Z1, /Z1	Encoder input signal (Line Driver) Open collector input: +5 V / +24 V (Note1) 1-phase or 2-phase input Max. input frequency: EMC-PG01L: 300KHz; EMC-PG02L: 30KHz
	PG2	A2, /A2, B2, /B2	Pulse input signal (Line Driver or Open Collector) Open collector input: +5V/+24V (Note1) 1-phase or 2-phase input Max. input frequency: EMC-PG01L: 300KHz; EMC-PG02L: 30KHz
	PG OUT	AO, /AO, BO, /BO, ZO, /ZO, SG	PG card output signals. Division frequency function: 1 ~ 255 times Max. output voltage for Line driver: 5V <sub>DC</sub> Max. output current: 50 mA Max. output frequency: EMC-PG01L: 300KHz; EMC-PG02L: 30KHz SG: The GND of PG card is the same as the host controller or PLC, so a common output signal is attained.

## EMC-PG01O / EMC-PG02O

		Terminals	Description
 <p>Set by Pr.10-00 ~ 10-02</p>	PG1	VP	Output voltage for power: +5V/+12V ± 5% (use FSW3 to switch +5V/+12V) Max. output current: 200mA
		DCM	Common for power and signal
		A1, /A1, /B1, /B1, Z1, /Z1	Encoder input signal (Line Driver or Open Collector) Open collector input: +5V/+24V (Note1) 1-phase or 2-phase input Max. input frequency: EMC-PG01O: 300KHz; EMC-PG02O: 30KHz
	PG2	A2, /A2, B2, /B2	Pulse input signal (Line Driver or Open Collector) Open collector input: +5V/+24V (Note1) 1-phase or 2-phase input Max. input frequency: EMC-PG01O: 300KHz; EMC-PG02O: 30KHz
	PG OUT	V+, /V-	Needs external power source for PG OUT circuit. Input voltage of power: +12V ~ +24V
		V-	Negative power supply input
		A/O, B/O, ZO,	PG card output signals. Division frequency function: 1 ~ 255 times Add a pull-up resistor to the open collector output signals to avoid signal interferences. [Three pull-up resistors are included in the package (1.8KΩ/1W)] Max. Output current: 20mA Max output frequency: EMC-PG01O: 300KHz; EMC-PG02O: 30KHz

## EMC-PG01R

		Terminals	Description
 <p>Set by Pr.10-00 ~ 10-02</p>	PG1	R1- R2	Resolver output power 7V <sub>rms</sub> , 10kHz
		S1,S2, S3, S4 S4,	Resolver input signal 3.5 ± 0.175V <sub>rms</sub> , 10kHz
	PG2	A2, /A2, B2, /B2	Pulse input signal (Line Driver or Open Collector) Open collector input: +5V/+24V (Note1) 1-phase or 2-phase input; Max. input frequency: 300KHz
	PG OUT	AO, /AO, BO, /BO, ZO, /ZO, SG	PG card output signals. Division frequency function: 1 ~ 255 times Max. output voltage for Line driver: 5V <sub>DC</sub> Max. output current: 50 mA Max. output frequency: 300 KHz SG: The GND of PG card is the same as the host controller or PLC, so a common output signal is attained.

# Accessories

## EMC-PG01U / EMC-PG02U

FJMP1  : Standard UVW Output Encoder;  : Delta Encoder

		Terminals	Description
 <p>Set by Pr.10-00 ~ 10-02</p>	PG1	VP	Output voltage for power: +5V/+12V ± 5% (use FSW3 to switch +5V/+12V) Max. output current: 200 mA
		DCM	Common for power and signal
		A1, /A1, B1, /B1, Z1, /Z1	Encoder input signal (Line Driver) 1-phase or 2-phase input. Max. input frequency: 300 KHz
		U1, /U1, V1, /V1, W1, /W1	Encoder input signal
	PG2	A2, /A2, B2, /B2	Pulse input signal Open collector input: +5V/+24V (Note1) 1-phase or 2-phase input; Max. input frequency: 300KHZ
	PG OUT	AO, /AO, BO, /BO, ZO, /ZO, SG	PG card output signals. Division frequency function: 1 ~ 255 times Max. output voltage for Line driver: 5 V <sub>DC</sub> Max. output current: 50 mA Max. output frequency: 300 KHz SG: The GND of PG card is the same as the host controller or PLC, so a common output signal is attained.

Note 1: For the Open Collector, set input voltage to 5 ~ 15mA and install a pull-up resistor

**[5V]** Recommend pull-up resistor: 100 ~ 220Ω, 1/2W and above

**[12V]** Recommend pull-up resistor: 510 ~ 1.35kΩ, 1/2W and above

**[24V]** Recommend pull-up resistor: 1.8k ~ 3.3kΩ, 1/2W and above

## Screw Specifications for Option Card Terminals

EMC-D42A/EMC-D611A EMC-BPS01	Wire gauge	24 ~ 12AWG (0.205 ~ 3.31 mm <sup>2</sup> )
	Torque	4 Kg-cm [3.47 lb-in]
EMC-R6AA	Wire gauge	24 ~ 16AWG (0.205 ~ 1.31 mm <sup>2</sup> )
	Torque	6 Kg-cm [5.21 lb-in]
EMC-PG01L / EMC-PG01O EMC-PG01R / EMC-PG01U EMC-PG02L / EMC-PG02O EMC-PG02U	Wire gauge	30 ~ 16AWG (0.0509 ~ 1.31 mm <sup>2</sup> )
	Torque	2 Kg-cm [1.74 lb-in]



# Accessories

## EMC-D42A

	Terminals	Description
 <p>I/O Extension Card</p>	COM	Common for multi-function input terminals Select SINK (NPN) / SOURCE (PNP) in J1 jumper / external power supply
	MI10 ~ MI13	Refer to parameters 02-26 ~ 02-29 to program the multi-function inputs MI10 ~ MI13. Internal power is applied from terminal E24: +24 V <sub>DC</sub> ±5% 200 mA, 5 W External power +24 V <sub>DC</sub> : max. voltage 30V <sub>DC</sub> , min. voltage 19V <sub>DC</sub> , 30W ON: the activation current is 6.5mA; OFF: leakage current tolerance is 10 μA
	MO10 ~ MO11	Multi-function output terminals (photocoupler) Duty-cycle: 50%; Max. output frequency: 100Hz Max. current: 50mA; Max. voltage: 48V <sub>DC</sub>
	MXM	Common for multi-function output terminals MO10, MO11(photocoupler) Max 48V <sub>DC</sub> 50mA

## EMC-D611A

	Terminals	Description
 <p>I/O Extension Card</p>	AC	AC power common for multi-function input terminal (Neutral)
	MI10 ~ MI15	Refer to Pr. 02.26 ~ Pr. 02.31 for multi-function input selection Input voltage: 100 ~ 130 Vac; Input frequency: 57 ~ 63Hz Input impedance: 27Kohm Terminal response time: ON: 10 ms; OFF: 20 ms

## EMC-R6AA

	Terminals	Description
 <p>Relay Extension Card</p>	RA10 ~ RA15 RC10 ~ RC15	Refer to Pr. 02.36 ~ Pr. 02.41 for multi-function input selection Resistive load: 3A(N.O.)/250V <sub>AC</sub> 5A(N.O.)/30V <sub>DC</sub> Inductive load (COS 0.4) 2.0A(N.O.)/250V <sub>AC</sub> 2.0A(N.O.)/30V <sub>DC</sub> It is used to output each monitor signal, such as for drive in operation, frequency attained or overload indication.

## EMC-BPS01

	Terminals	Description
 <p>24V Power Shift Card</p>	24V GND	When the AC motor drive power is off, the external power supply card provides external power to the network system, PLC function, and other functions to allow continued operations. Input power: 24V <sub>DC</sub> ±5% Maximum input current: 0.5A Note: Do not connect the control terminal +24 V (Digital control signal common: SOURCE) directly to the EMC-BPS01 input terminal 24 V. Do not connect control terminal GND directly to the EMC-BPS01 input terminal GND.

## ■ CMC-MOD01



Network Interface

### Features

- ▶ MDI/MDI-X auto-detect
- ▶ Virtual serial port. Supports MODBUS TCP protocol
- ▶ AC motor drive keypad/Ethernet configuration
- ▶ E-mail alarm
- ▶ Baud rate: 10/100Mbps auto-detect

### Network Interface

<b>Interface</b>	RJ-45 with Auto MDI/MDIX	<b>Transmission speed</b>	10/100 Mbps Auto-Detect
<b>Number of ports</b>	1 Port	<b>Network protocol</b>	ICMP, IP, TCP, UDP, DHCP, SMTP, MODBUS over TCP/IP, Delta Configuration
<b>Transmission method</b>	IEEE 802.3, IEEE 802.3u		
<b>Transmission cable</b>	Category 5e shielding 100M		

## ■ CMC-EIP01



Network Interface

### Features

- ▶ MDI/MDI-X auto-detect
- ▶ Supports MODBUS TCP and Ethernet/IP protocol
- ▶ Baud rate: 10/100Mbps auto-detect
- ▶ AC motor drive keypad/Ethernet configuration
- ▶ Virtual serial port

### Network Interface

<b>Interface</b>	RJ-45 with Auto MDI/MDIX	<b>Transmission speed</b>	10/100 Mbps Auto-Detect
<b>Number of ports</b>	1 Port	<b>Network protocol</b>	ICMP, IP, TCP, UDP, DHCP, SMTP, MODBUS over TCP/IP, Delta Configuration
<b>Transmission method</b>	IEEE 802.3, IEEE 802.3u		
<b>Transmission cable</b>	Category 5e shielding 100M		

## ■ CMC-PD01



### Features

- ▶ Supports PZD control data exchange
- ▶ Supports PKW polling AC motor drive parameters
- ▶ Supports user diagnosis function
- ▶ Auto-detects baud rates; supports Max. 12Mbps

### PROFIBUS DP Connector

<b>Interface</b>	DB9 connector
<b>Transmission method</b>	High-speed RS-485
<b>Transmission cable</b>	Shielded twisted pair cable
<b>Electrical isolation</b>	500 V <sub>DC</sub>

### Communication

<b>Message type</b>	Cyclic data exchange
<b>Module name</b>	CMC-PD01
<b>GSD document</b>	DELA08DB.GSD
<b>Company ID</b>	08DB (HEX)
<b>Serial transmission speed supported (auto-detection)</b>	9.6 kbps; 19.2 kbps; 93.75 kbps; 187.5 kbps; 125 kbps; 250 kbps; 500 kbps; 1.5 Mbps; 3 Mbps; 6 Mbps; 12 Mbps (bits per second)

# Accessories

## ▪ CMC-DN01 Features



- ▶ Based on the high-speed communication interface of Delta HSSP protocol, able to conduct immediate control of AC motor drive
- ▶ Supports Group 2 only connection and polling I/O data exchange
- ▶ For I/O mapping, supports Max. 32 words of input and 32 words of output
- ▶ Supports EDS file configuration in DeviceNet configuration software
- ▶ Supports all baud rates on DeviceNet bus: 125kbps, 250kbps, 500kbps and extendable serial transmission speed mode
- ▶ Node address and serial transmission speed can be set up on AC motor drive
- ▶ Power supplied from AC motor drive

### DeviceNet Connector

<b>Interface</b>	5-Pin 5.08mm pluggable connector
<b>Transmission method</b>	CAN
<b>Transmission cable</b>	Shielded twisted pair cable (with 2 power cables)
<b>Transmission speed</b>	125kbps, 250kbps, 500kbps and extendable serial transmission speed mode
<b>Network protocol</b>	DeviceNet protocol

### DeviceNet Connector

<b>Interface</b>	50 PIN communication terminal
<b>Transmission method</b>	SPI communication
<b>Terminal function</b>	1. Communicating with AC motor drive 2. Transmitting power supply from AC motor drive
<b>Communication protocol</b>	Delta HSSP protocol

## ▪ EMC-COP01

### RJ-45 Pin definition

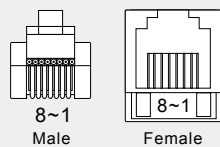

Pin	Pin name	Definition
1	CAN_H	CAN_H bus line (dominant high)
2	CAN_L	CAN_L bus line (dominant low)
3	CAN_GND	Ground/0V/V-
6	CAN_GND	Ground/0V/V-

### Network Interface

<b>Interface</b>	RJ-45
<b>Number of ports</b>	1 Port
<b>Transmission method</b>	CAN
<b>Transmission cable</b>	CAN standard cable
<b>Transmission speed</b>	1 M 500 k 250 k 125 k 100 k 50 k
<b>Communication protocol</b>	CANopen

# Accessories

## ▪ CANopen Communication Cable

Model: TAP-CB05, TAP-CB10

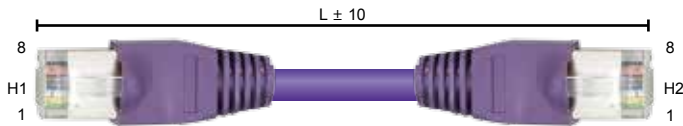

Title	Part No.	L	
		mm	inch
1	UC-CMC003-01A	300	11.8
2	UC-CMC005-01A	500	19.6
3	UC-CMC010-01A	1000	39
4	UC-CMC015-01A	1500	59
5	UC-CMC020-01A	2000	78.7
6	UC-CMC030-01A	3000	118.1
7	UC-CMC050-01A	5000	196.8
8	UC-CMC100-01A	10000	393.7
9	UC-CMC200-01A	20000	787.4

## ▪ Digital Keypad Accessories: RJ45 Extension Leads and CMC-EIP01 Cables

Title	Part No.	Explanation
1	CBC-K3FT	RJ45 extension lead, 3 feet (approximately 0.9m)
2	CBC-K5FT	RJ45 extension lead, 5 feet (approximately 1.5m)
3	CBC-K7FT	RJ45 extension lead, 7 feet (approximately 2.1m)
4	CBC-K10FT	RJ45 extension lead, 10 feet (approximately 3m)
5	CBC-K16FT	RJ45 extension lead, 16 feet (approximately 4.9m)

# Model Name

**VFD 750 CT 43 F - 00 A6**

**Product Name**  
Variable Frequency Drive

### Applicable Motor Capacity

110 : 11kW      370 : 37kW  
 150 : 15kW      450 : 45kW  
 185 : 18.5kW    550 : 55kW  
 220 : 22kW      750 : 75kW  
 300 : 30kW      900 : 90kW

**CT2000 series**

**Cooling Method**  
 A, B : Airway cooling  
 C : Fan cooling  
 6 = 6 M/sec @fc = 2 kHz  
 8 = 8.5 M/sec @fc = 2 kHz

**IP Protection Level**  
 00 : IP00 UL Open Type  
 21 : IP20 NEMA1

**Installation Method**  
 F : Flange mount  
 A : Wall mount

**Input Voltage**  
 43 : 460V 3-Phase

## Ordering Information

### ■ Flange mount models

Frame		Power Range	Models
Frame B		460 V: 11 kW ~ 18.5 kW	VFD110CT43F00B VFD150CT43F00B VFD185CT43F00B
Frame C		460 V: 22 kW ~ 37 kW	VFD220CT43F00B VFD300CT43F00B VFD370CT43F00B
Frame D		460 V: 45 kW ~ 90 kW	VFD450CT43F00B VFD550CT43F00B VFD750CT43F00A6 VFD900CT43F00A8

### ■ Wall mount models

Frame		Power Range	Models
Frame B		460 V: 11 kW ~ 18.5 kW	VFD110CT43A21C VFD150CT43A21C VFD185CT43A21C
Frame C		460 V: 22 kW ~ 37 kW	VFD220CT43A21C VFD300CT43A21C VFD370CT43A21C
Frame D		460 V: 45 kW ~ 55 kW	VFD450CT43A00C VFD550CT43A00C





## Attention

### Standard Motors

#### Used with 400V Standard Motors

It is recommended to add an AC output reactor when using with a 400V standard motor to prevent damage to motor insulation.

#### Torque Characteristics and Temperature Rise

When a standard motor is drive controlled, the motor temperature will be higher than with DOL operation.

Please reduce the motor output torque when operating at low speeds to compensate for less cooling efficiency.

For continuous constant torque at low speeds, external forced motor cooling is recommended.

#### Vibration

When the motor drives the machine, resonances may occur, including machine resonances. Abnormal vibration may occur when operating a 2-pole motor at 60Hz or higher.

#### Noise

When a standard motor is drive controlled, the motor noise will be higher than with DOL operation.

To lower the noise, please increase the carrier frequency of the drive. The motor fan can be very noisy when the motor speed exceeds 60Hz.

### Special Motors

#### High-speed Motor

To ensure safety, please try the frequency setting with another motor before operating the high-speed motor at 120Hz or higher.

#### Explosion-proof Motor

Please use a motor and drive that comply with explosion-proof requirements.

#### Submersible Motor & Pump

The rated current is higher than that of a standard motor.

Please check before operation and select the capacity of the AC motor drive carefully.

The motor temperature characteristics differ from a standard motor, please set the motor thermal time constant to a lower value.

#### Brake Motor

When the motor is equipped with a mechanical brake, the brake should be powered by the mains supply.

Damage may occur when the brake is powered by the drive output. Please DO NOT drive the motor with the brake engaged.

#### Gear Motor

In gearboxes or reduction gears, lubrication may be reduced if the motor is continuously operated at low speeds.

Please DO NOT operate in this way.

#### Synchronous Motor

These motors need suitable software for control. Please contact Delta for more information.

#### Single-phase Motor

Single-phase motors are not suitable for being operated by an AC Motor Drive. Please use a 3-phase motor instead when necessary.

### Environmental Conditions

#### Installation Position

1. The drive is suitable for installation in a place with ambient temperature from -10°C to 50°C.
2. The surface temperature of the drive and brake resistor will rise under specific operation conditions. Therefore, please install the drive on materials that are noncombustible.
3. Ensure that the installation site complies with the ambient conditions as stated in the manual.

### Wiring

#### Limit of Wiring Distance

For remote operation, please use twist-shielding cable and the distance between the drive and control box should be less than 20m.

#### Maximum Motor Cable Length

Motor cables that are too long may cause overheating of the drive or current peaks due to stray capacitance.

Please ensure that the motor cable is less than 30m.

If the cable length can't be reduced, please lower the carrier frequency or use an AC reactor.

#### Choose the Right Cable

Please refer to current value to choose the right cable section with enough capacity or use recommended cables.

#### Grounding

Please ground the drive completely by using the grounding terminal.

### How to Choose the Drive Capacity

#### Standard Motor

Please select the drive according to applicable motor rated current listed in the drive specification.

Please select the next higher power AC drive in case higher starting torque or quick acceleration/deceleration is needed.

#### Special Motor

Please select the drive according to: Rated current of the drive > rated current of the motor

### Transportation and Storage

Please transport and store the drive in a place that meets environment specifications.

### Peripheral Equipment

#### Molded-Case Circuit Breakers (MCCB)

Please install the recommended MCCB or ELCB in the main circuit of the drive and make sure that the capacity of the breaker is equal to or lower than the recommended one.

#### Add a Magnetic Contactor(MC) in the Output Circuit

When a MC is installed in the output circuit of the drive to switch the motor to commercial power or other purposes, please make sure that the drive and motor are completely stopped and remove the surge absorbers from the MC before switching it.

#### Add a Magnetic Contactor (MC) in the Input Circuit

Please only switch the MC ONCE per hour or it may damage the drive. Please use RUN/STOP signal to switch many times during motor operation.

#### Motor Protection

The thermal protection function of the drive can be used to protect the motor by setting the operation level and motor type (standard motor or variable motor). When using a high-speed motor or a water-cooled motor the thermal time constant should be set to a lower value.

When using a longer cable to connect the motor thermal relay to a motor, high-frequency currents may enter via the stray capacitance.

It may result in malfunctioning of the relay as the real current is lower than the setting of thermal relay. Under this condition, please lower the carrier frequency or add an AC reactor to solve this.

#### DO NOT Use Capacitors to Improve the Power Factor

Use a DC reactor to improve the power factor of the drive. Please DO NOT install power factor correction capacitors on the main circuit of the drive to prevent motor faults due to over current.

#### Do NOT Use Surge Absorber

Please DO NOT install surge absorbers on the output circuit of the drive.

#### Lower the Noise

To ensure compliance with EMC regulations, usually a filter and shielded wiring is used to lower the noise.

#### Method Used to Reduce the Surge Current

Surge currents may occur in the phase-lead capacitor of the power system, causing an overvoltage when the drive is stopped or at low loads.

It is recommended to add a DC reactor to the drive.