



AdaptaBuzzer™

Weatherproof DC & AC Models

B-8698 & B-8699 Series



Edwards B-8698 & B-8699 AdaptaBuzzers are the finest, heavy duty buzzers available. Sound is produced by the hammer action of a vibrating armature against the cover and starts and stops instantly with current impulse. The cover is secured to the unit's cast box by a cast aluminum threaded ring and sealed with a neoprene gasket. Two mounting lugs are provided for wall mounting. A 1/2" (13mm) tapped conduit entrance is provided on one side for field wiring. Wiring connections are made in the base and the cover assembly plugs into a receptacle in the base.

Ideal for use in areas where a louder signal would be distracting. Often used for timing, scheduling, paging, and general alarm applications. Typical indoor and weatherproof installations include construction sites, shipping docks, and paper mills.

FEATURES

- > Heavy gauge steel cover
- > Die cast aluminum housing
- > Vibrating armature
- > Gray finish

AGENCY APPROVALS

- > B-8699 Series UL 464 Listed
- > NEMA Type 3R

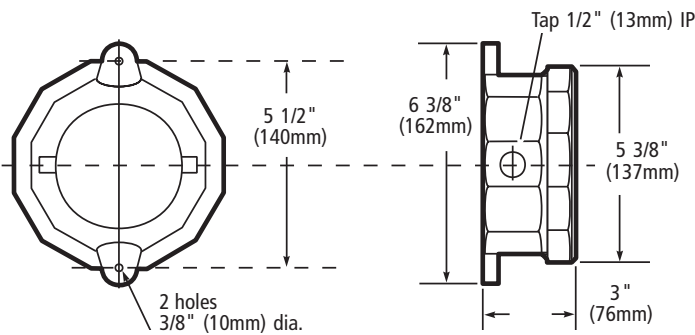

Cat No.	Volts	Amps	VA	DC Coil Res (ohms)	dB at 1m / 10 ft.
B-8698-E1	12V DC	1.5	18	4.8	95/89
B-8698-G1	24V DC	1.0	24	21.5	75 db min.
B-8698-P1	125V DC	0.2	25	103	
B-8698-S1	240V DC	0.1	24	600	
B-8699-G5	24V AC 60 Hz	1.1	26.4	5.0	95/89
B-8699-N5	120V AC 60 Hz	0.2	24	146	75 db min.