

AdaptaHorn® Double Projector Horn

Weatherproof, NEMA Type 4X

B-N-8590 & B-8599 Series

FEATURES

- > Convenient plug-in assembly
- > Corrosion resistant heat flowed epoxy finish
- > Completely assembled
- > Gasket sealed
- > External volume control screw

AGENCY APPROVALS

- > UL Listed 60 Hz (B-N-8590)
- > UL Listed NEMA Type 4X enclosure

SPECIFICATIONS

- > Heavy duty die cast aluminum
- > 7" (178mm) seamless steel projector
- > Vibrating diaphragm
- > Tungsten contacts with arc suppressor (B-8599)

The Edwards B-N-8590 AC & B-8599 DC Series vibrating horns are designed for use where a loud and distinctive signals are needed. The sound mechanism of the signal starts and stops instantly with current impulse. The projector is connected to the heavy duty die cast aluminum housing by a cast aluminum, threaded ring.

Two mounting lugs are provided on either side of the unit for wall mounting. The housing is tapped on one side for 1/2" (13mm) conduit to allow for field wiring installation.

Used where sound dispersion in opposite directions is required or specified. Applications include timing, scheduling, paging, and general alarm at construction sites, textile and paper mills, lumber yards, and shipping docks.



TECHNICAL INFORMATION

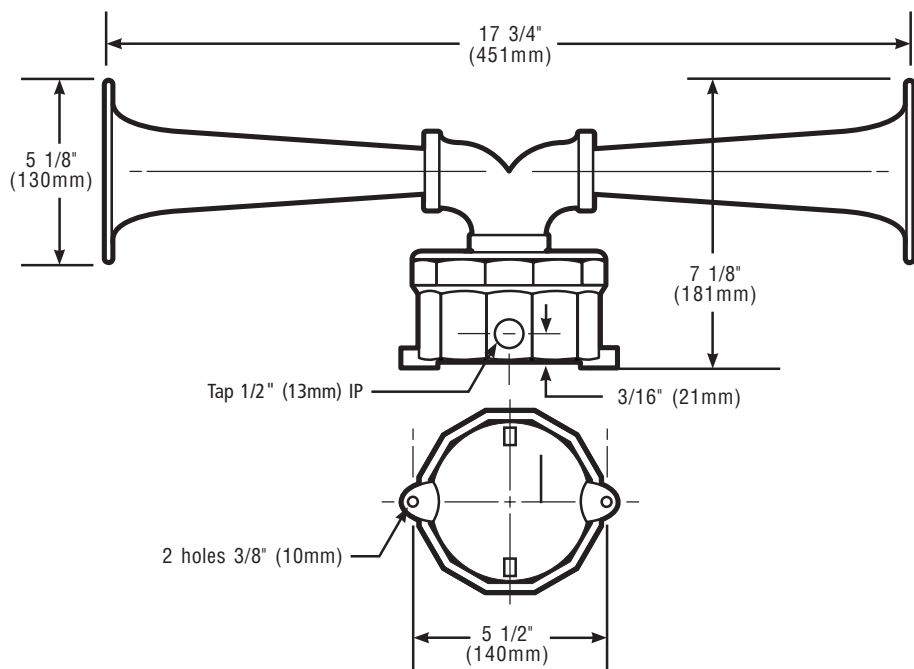

Cat. No.	Volts	Amps	V A	DC coil Res. (Ohms)	dB at 10 Ft.
B-N-8590-E5	12V AC	1.6	19.2	3	95
B-N-8590-G5	24V AC	1.1	26.4	5	
B-N-8590-N5	120V AC	.2	24	146	
B-8599-E1	12V DC	1.5	18	3	93
B-8599-G1	24V DC	1	24	21.5	
B-8599-P1	125V DC	.2	25	103	
B-8599-S1	250V DC	.1	25	600	