

## Order codes

- B.2 Series M - Auxiliary contactors
- B.6 Series RL - Auxiliary contactors

## Series M - Auxiliary contactors

- B.9 Technical data
- B.15 Terminal numbering
- B.17 Dimensions

## Series RL - Auxiliary contactors

- B.18 Technical data
- B.21 Terminal numbering
- B.24 Dimensions
- B.26 Alphabetical index

POWER DEVICES

Contactors and overload relays

Auxiliary contactors

Motor protection devices

Applications

Control and signalling units

Intro

A

B

C

D

E



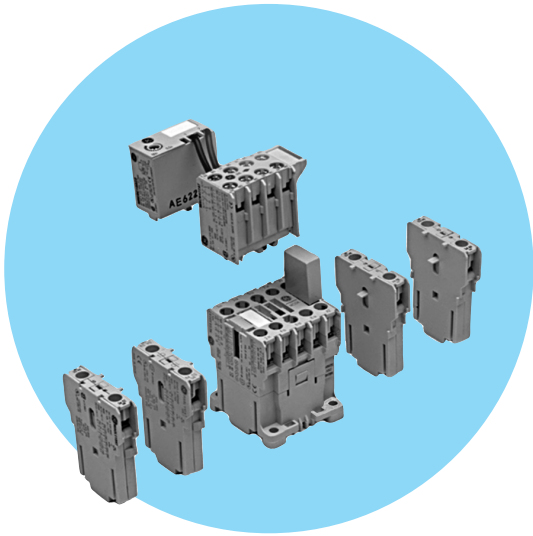

## Auxiliary contactors $I_{th} = 16A$

- Control circuit: Alternating current up to 600V  
Direct current up to 250V
- Terminal numbering in accordance with EN 50011
- Fixing system for rapid and simple mounting by clamping onto standard 35mm DIN rail (EN 50022).
- 6kV rated impulse withstand strength
- Screw and push-on terminals protected against accidental contacts in accordance with VDE 0106 T.100 and VBG4.
- Printed circuit version.
- Ring terminal version.
- Facility to mount instant or timed auxiliary contact blocks and voltage suppressor blocks.
- Maximum number of auxiliary contacts to add: 6
- Degree of protection IP20 (EN 60529).
- According to IEC/EN 60947-1.

### Standards

IEC/EN 60947-5-1	BS 4794
IEC/EN 60947-1	CENELEC HD 420
EN 50002	NFC 63-110
EN 50005	NFC 63-140
EN 50011	CSA C22.2/14
UL 508	VDE 0660

### General data

Maximum number of contacts (MCR...)	4
Rated thermal current ( $I_{th}$ ) $\theta \leq 60^\circ$	(A) 16
Rated operational voltage ( $U_e$ ) acc. IEC 60947-1	(V) 690
Insulation voltage ( $U_i$ ) acc. IEC 60947-1	(V) 750

#### Utilisation category:

AC-15	V	110	220/240	380/400	415	440	500	660/690
	A	6	6	4	4	3	2.5	1.5

DC-13	V	24	48	110	220
	A	5	3.5	1.2	0.6

### Approvals



cULus

CE



Lloyd's Register



Bureau Veritas



RINA

### Standard voltages

To complete the catalogue number, replace the symbol  $\blacklozenge$  by the code corresponding to the voltage and frequency of the control circuit.

#### AC Coils

AC	1	2	9	J	K	M	6	7	N	U	W	Y
50/60Hz	24	42	48				220-230	240				
50 Hz				110-115	115-127					380-400	415-440	500
60Hz				110-120		208-220			277	440	480	600

#### Voltage operating limits of dual-frequency coil:

at 60Hz =  $0.85 \text{ a } 1.1 \times U_s$

at 50Hz =  $0.8 \text{ a } 1.1 \times U_s$  for uninterrupted duty (ED=100%), temperature =  $40^\circ\text{C}$

#### DC Coils

-	B	D	G	J
Voltage	12	24	48	110

#### DC Wide Range Coils

-	WD	WG	WI	WJ	WL	WN	WS
Voltage	24	48	72	110	125	220	250

#### Operating voltage limits with DC coils:

Standard =  $0.8 \text{ to } 1.1 \times U_s$

Wide range =  $0.7 \text{ to } 1.3 \times U_s$

- Order codes [page B.3](#)
- Auxiliary contacts blocks [page B.3](#)
- Accessories [page B.4](#)
- Technical data [page B.18](#)
- Dimensions [page B.24](#)



Auxiliary contactors\*



Contacts acc. EN 50011			Control circuit: alternating current			Control circuit: direct current		
			Cat. no. <sup>(1)</sup>	Ref. no. see bottom	Pack.	Cat. no. <sup>(1)</sup>	Ref. no. see bottom	Pack.
<b>Screw terminal</b>								
40E	4	0	MCRA040AT	◆	5	MCRC040AT	◆	10
31E	3	1	MCRA031AT	◆	5	MCRC031AT	◆	10
22E	2	2	MCRA022AT	◆	5	MCRC022AT	◆	10
13E	1	3	MCRA013AT	◆	5	MCRC013AT	◆	10
04E	0	4	MCRA004AT	◆	5	MCRC004AT	◆	10

(1) To complete the catalogue number, replace the symbol ◆ by the code corresponding to the voltage and frequency of the control circuit. (see pag. B.8).

(2) Terminal: - with wire 1.5mm<sup>2</sup>: Ie = 16A - with wire 1mm<sup>2</sup>: Ie = 10A  
 Insulated terminal type B 2.8x0.8 with wire 1mm<sup>2</sup>: Ie = 8A to DIN 46247  
 Faston terminal 1x6.3 on request, replace the letter F by H in the catalogue number

(\*) Only available order codes listed in the alphabetical index

Auxiliary contactors interface



Contacts acc. EN 50011			Control circuit: direct current 24V / 1.2W <sup>(3)</sup>			Control circuit: direct current 24V / 2W <sup>(4)</sup>		
			Operating limits from 19 to 30V (0.8-1.25xUs)			Operating limits from 17 to 30V (0.7-1.25xUs)		
			Cat. no.	Ref. no.	Pack.	Cat. no.	Ref. no.	Pack.
<b>Screw terminal</b>								
40E	4	0	MCRI040ATD	100530	5	MCRK040ATD	100533	10
31E	3	1	MCRI031ATD	100531	5	MCRK031ATD	100534	10
22E	2	2	MCRI022ATD	100532	5	MCRK022ATD	100535	10

(3) No possibility of adding instantaneous auxiliary blocks.

(4) Facility to mount instantaneous auxiliary contact block of two contacts (MARN2...) or two instantaneous auxiliary contact blocks of one contact (MARL1...).

Instantaneous auxiliary contacts blocks



Front mounting

Number of contacts	Combination with MCRA040AT ◆ (40E) according to EN 50011	Contacts acc. to EN 50005			Cat. no.	Ref. no.	Pack.
		Designation (block marking)					
<b>Screw terminal</b>							
2	60E	20	2	0	MARN220AT	100994	10
2	51E	11	1	1	MARN211AT	100993	10
2	42E	02	0	2	MARN202AT	100992	10
<b>Screw terminal</b>							
4	80E	40	4	0	MARN440AT	100991	10
4	71E	31	3	1	MARN431AT	100990	10
4	62E	22	2	2	MARN422AT	100989	10
4	53E	13	1	3	MARN413AT	100988	10
4	44E	04	0	4	MARN404AT	100987	10

Instantaneous auxiliary contacts blocks







Front mounting

Number of contacts	Combination with MCRA040AT ◆ (40E) according to EN 50011	Contacts acc. to EN 50005			Cat. no.	Ref. no.	Pack.
		Designation (block marking)					
• One or two blocks to cover combinations of 5 or 6 contacts without increasing the height of the basic unit.							
<b>Screw terminal</b>							
1	50E	10	1	0	MARL110AT	100513	10
1	-	01	0	1	MARL101AT	100514	10
• One or two additional blocks, when 9 or 10 contacts are required (combination possible with the front mounting block)							
• One or two additional blocks on both sides, to cover up to 8 contacts (combination only possible with lateral blocks)							
<b>Screw terminal</b>							
1	50E	10	1	0	MARL110ATS	100519	10
1	-	01	0	1	MARL101ATS	100520	10

Insulated terminal type B 2.8x0.8 with wire 1mm<sup>2</sup>: Ie = 8A



### Accessories

	For use with	Time	Function	Ue	Cat. no.	Ref. no.	Pack.	
	Electronic timer block	Lateral or front fixing on the contactor						
	MCR, MC_ ...	0.5 - 60 sec.	Delay ON	24 to 250V AC/DC	MREBC10AC2	100541	10	
	MCR, MC_ ...	0.2 - 24 sec.	Delay ON	24 to 250V AC/DC	MREBC20AC2	100542	10	
	Timer fitment	For fixing onto 35mm DIN-rail (EN 5022)						
	MREBC...				MVB0R	100543	10	
	Voltage suppressor block	Connection and (plug-in) fixing onto front of the contactor						
		MCRA, MC_ ...	RC	AC	12 to 60V 50/60Hz	MP0AAE1	100544	10
		MCRA, MC_ ...	RC	AC	72 to 250V 50/60Hz	MP0AAE2	100545	10
		MCRC, MC_ ...	Diode	DC	6 to 250V DC	MP0CAE3	100546	10
		MCRC, MC_ ...	Varistor	AC/DC	24-48V	MP0DAE4	100536	10
		MCRC, MC_ ...	Varistor	AC/DC	50-127V	MP0DAE5	204848	10
		MCRC, MC_ ...	Varistor	AC/DC	130-250V	MP0DAE6	204849	10
	Mechanical interlock	Kit comprising mechanical interlock and contactor jointing parts						
		MCR, MC_ ...				MMH0	100547	10
	Identification	For use with			Cat. no.	Ref. no.	Pack.	
		MCR, MC_ ...	Sheets of labels (10 sheets of 260 labels each)		EAT 260	100547	10	
		MCR, MC_ ...	Labelling plate base. Plug-in labelling plate bases (50 pieces in one pack)		SPR	100549	10	

Everything is under control

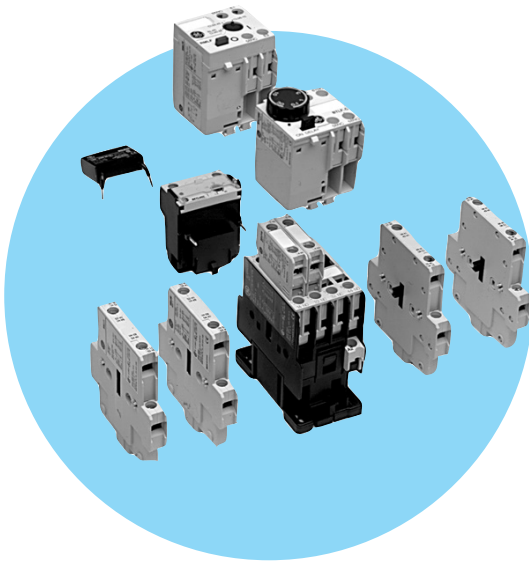

## Auxiliary contactors *I<sub>th</sub>* = 20A

- Control circuit: Alternating current up to 690V  
Direct current up to 440V
- Terminal numbering in accordance with EN 50005 and EN 50011
- Fixing system for rapid and simple mounting onto standard 35mm DIN-rail (EN 50022-35)
- Terminals protected against accidental contact in accordance with VDE 0106 T.100, VBG4
- Ring terminal versions
- Three coil terminals
- Facility to mount side and/or front instantaneous contact blocks, timed auxiliary contacts, mechanical latch, voltage suppressor blocks and interface modules.
- Degree of protection IP20 (EN 60529)

### Standards

IEC/EN 60947-5-1	BS 4794
IEC/EN 60947-1	CENELEC HD410
EN 90947	CENELEC HD420
EN 60947	NFC 63-110
EN 50005	NFC 63-140
EN 50011	CSA C22.2/14
UL 508	VDE 0660/102
NEMA ICS 1	

### General data

<b>Maximum number of contacts (RL...)</b>	4
<b>Rated thermal current (I<sub>th</sub>) θ ≤ 55°</b>	(A) 20
<b>Rated operational voltage (U<sub>e</sub>)</b>	(V) 690
<b>Insulation voltage (U<sub>i</sub>)</b>	(V) 1000

#### Utilisation category:

AC-15	V	120	230/220	400/380	440/415	500	690/660
A	10	10	6	5	4	2	

DC-13	V	24	48	110	220	440
A	6	4	2	0.7	0.35	

### Approvals/Marking



Lloyd's Register



Bureau Veritas



RINA

### Standard voltages

#### AC Coils

-	1	2	9	J	K	L	6	7	N	U	Y
50/60Hz	24	42	48				220-230	240			
50 Hz				110-115	127					380-400	500
60Hz				110-120		208			277	440	600

#### DC Coils

-	B	D	G	H	J	K	N	T
Voltage	12	24	48	60	110	120-125	220	250

#### DC Wide Range Coils

-	WD	WE	WG	WI	WJ	WN
Voltage	24	33	48	72	110	220

- Order codes ● page B.7
- Accessories ● page B.8
- Technical data ● page B.9
- Dimensions ● page B.24



Auxiliary contactors\*



Contacts	Control circuit: alternating current up to 690V			Control circuit: Direct current up to 440V		
	Cat. no. <sup>(1)</sup>	Ref. no. see bottom	Pack.	Cat. no. <sup>(1)</sup>	Ref. no. see bottom	Pack.
<b>Screw terminal</b>						
4 0 0 0	RL4RA040T	◆	5	RL4RD040T	◆	10
3 1 0 0	RL4RA031T	◆	5	RL4RD031T	◆	10
2 2 0 0	RL4RA022T	◆	5	RL4RD022T	◆	10
0 4 0 0	RL4RA004T	◆	5	RL4RD004T	◆	10
1 1 1 1	RL4RA022G	◆	5	RL4RD022G	◆	10
<b>Ring terminal</b>						
4 0 0 0	RL4RA040R	◆	5	RL4RD040R	◆	10
3 1 0 0	RL4RA031R	◆	5	RL4RD031R	◆	10
2 2 0 0	RL4RA022R	◆	5	RL4RD022R	◆	10
0 4 0 0	RL4RA004R	◆	5	RL4RD004R	◆	10

(1) To complete the catalogue number, replace the symbol ◆ by the code corresponding to the voltage and frequency of the control circuit. (see page B.6).

(\*) Only available order codes listed in the alphabetical index

Auxiliary contactors

Instantaneous		Number of contacts	Contacts				Function	Time	Cat. no.	Ref. no.	Pack.	
			.3	.1	.7	.5						
Frontal mounting			.4	.2	.8	.6						
		<b>Screw terminal</b>										
		1	1	0	0	0		BCLF10	104700	10		
		1	0	1	0	0		BCLF01	104701	10		
		1	0	0	1	0		BCLF10G	104702	10		
		1	0	0	0	1		BCLF01G	104703	10		
		<b>Ring terminal</b>										
		1	1	0	0	0		BCRF10	108901	10		
		1	0	1	0	0		BCRF01	108902	10		
Side mounting		<b>Screw terminal</b>										
		2	2	0	0	0		BRLL20	104704	10		
		2	1	1	0	0		BRLL11	104705	10		
		2	0	2	0	0		BRLL02	106622	10		
Pneumatic timer blocks		<b>Screw terminal</b>										
Frontal mounting		2	0	0	1	1	Delayed ON	0,1 - 30 sec.	BTLF30C	104709	10	
		2	0	0	1	1	Delayed ON	1 - 60 sec.	BTLF60C	104710	10	
		2	0	0	1	1	Delayed OFF	0,1 - 30 sec.	BTLF30D	104711	10	
		2	0	0	1	1	Delayed OFF	1 - 60 sec.	BTLF60D	104712	10	
		<b>Ring terminal</b>										
		2	0	0	1	1	Delayed ON	0,1 - 30 sec.	BTRF30C	108903	10	
		2	0	0	1	1	Delayed ON	1 - 60 sec.	BTRF60C	108904	10	
		2	0	0	1	1	Delayed OFF	0,1 - 30 sec.	BTRF30D	108905	10	
		2	0	0	1	1	Delayed OFF	1 - 60 sec.	BTRF60D	108906	10	
		Sealing cover protection for pneumatic timer								BTLFX	113001	5



### Accessories

	Number of contacts	Contacts				Cat. no.	Ref. no.	Pack.
		.3   .4	.1   .2	.7   .8	.5   .6			
	Mechanical	-	-	-	-	BELA	104723	5
	Mechanical / electrical	2	0	2	-	BELA02	104724	5

	Mechanical latch blocks	Frontal mounted to the contactor				RL4RA..., RL4RD...	RMLF ♦	see bottom	20
---	-------------------------	----------------------------------	--	--	--	--------------------	--------	------------	----

(1) To complete the catalogue number, replace the symbol ♦ by the code corresponding to the voltage and frequency of the control circuit.

♦	D	G	J	N	U
50Hz	24, 32	42, 48	110, 115, 120, 127	220, 230, 240	380, 400, 415, 440, 480
60HZ	24, 32	48, 60	110, 115, 120, 127	208, 220, 240, 277	380, 400, 415, 440, 480
DC	24, 32, 36	42, 48	110, 120, 125	220, 230, 240, 250	440

	For use with	Type	Control circ.	Ue	Cat. no.	Ref. no.	Pack.
	Transient voltage suppressor block	Directly connected parallel to the coil terminals, allows simultaneous use with auxiliary contact blocks.					
	RL4RA...	R/C	AC	12V ... 48V	BSLR2G	104713	10
	RL4RA...	R/C	AC	50V ... 127V	BSLR2K	104714	10
	RL4RA...	R/C	AC	130V ... 250V	BSLR2R	104715	10
	RL4RD...	Diode	DC		BSLDZ	104719	10
	RL4RA..., RL4RD...	Varistor	AC / DC	24V ... 48V	BSLV3G	104720	10
	RL4RA..., RL4RD...	Varistor	AC / DC	50V ... 127V	BSLV3K	104721	10
	RL4RA..., RL4RD...	Varistor	AC / DC	130V ... 250V	BSLV3R	104722	10
RL4RA..., RL4RD...	Varistor	AC / DC	277V ... 500V	BSLV3U	110836	10	

	For use with		Cat. no.	Ref. no.	Pack.
Identification	RL4RA..., RL4RD...	Sheets of labels (10 sheets of 260 labels each)	EAT 260	100548	1
	RL4RA..., RL4RD...	Labelling plate base. Plug-in labelling plate bases (50 pieces in one pack)	SPR	100549	1

	For use with	Control circuit	Function	Time	Cat. no.	Ref. no.	Pack.
	Electronic timer module	Directly connected parallel to the coil terminals, allows simultaneous use with auxiliary contact blocks.					
	RL4...	24-250V AC/DC	Delayed ON	0.1 - 2 sec.	BETL02C	113602	5
	RL4...	24-250V AC/DC	Delayed ON	1.5 - 45 sec.	BETL45C	113603	5
	RL4...	24-250V AC/DC	Delayed OFF	0.1 - 2 sec.	BETL02D	113604	5
	RL4...	24-250V AC/DC	Delayed OFF	1.5 - 45 sec.	BETL45D	113605	5

## Technical data

### General

Maximum number of contacts (MCR...)	4
Rated thermal current (Ith) $\theta \leq 60^\circ$	16A
Rated operational voltage (Ue) acc. IEC 60947.1	690V
Insulation voltage (Ui) acc. IEC 60947.1	750V

### Conformity to standards

IEC / EN 60947-5-1	IEC / EN 60947-1	BS 4794
EN 50002	EN 50005	EN 50011
NFC 63-110	NFC 63-140	CENELEC HD 420
CSA C22.2/14	VDE 0660	UL 508

### Approvals

cULus	DEMKO	NEMKO
SEMKO	SETI	RINA
Lloyd's Register	Bureau Veritas	CE

### Ambient conditions

Storage temperature	-55°C to +80°C	
Operation temperature	-40°C to +60°C	
Altitude	up to 3000m	Nominal values
	from 3000 to 4000m	90%le 80%Ue
	from 4000 to 5000m	80%le 75%Ue

### Climatic resistance (IEC 68-2)

Continuous tests	40 / 125 / 56	
Cold (72h)	Temperature	-40°C
	Relative humidity	< 50%
Dry heat (96h)	Temperature	+125°C
	Relative humidity	< 50%
Humid heat (56 days)	Temperature	+40°C
	Relative humidity	95%
Cyclical tests (6 cycles)		
Humid heat		
	First half-cycle (12h)	
Low temperature	Relative humidity	93%
	Second half-cycle (12h)	
Low temperature	Relative humidity	95%

### Shock resistance (IEC 68-2-27)

Continuously closed (at 0.8Us)		
Admissible acceleration	25 g	
Impulse duration	11ms	
Continuously opened (no voltage)		
Admissible acceleration	20 g	
Impulse duration	11ms	

### Vibration resistance (IEC 68-2-6)

Continuously closed (at 0.8Us)		
Admissible acceleration	15 g	
Sweep between	10 - 200Hz	
Continuously opened (no voltage)		
Admissible acceleration	5 g AC - 3.5g DC	
Sweep between	10 - 200Hz	

### Mounting positions

With the same pick-up and drop-out voltage  
With the same rated power

-7% of connection voltage  
+4% of disconnection voltage  
With the same rated power

-7% of connection voltage  
+4% of disconnection voltage  
With the same rated power

### Terminal capacity

Terminal with screw M3.5 Tightening torque (with pozidrive head and safety flange)	0.8 Nm - 7 Lb-in	
Solid wire	mm <sup>2</sup>	0.75 to 2 x 2 w.
Flexible wire without terminal	mm <sup>2</sup>	0.75 to 2.5 x 2 w.
Flexible wire with terminal with cap	mm <sup>2</sup>	0.75 to 2.5 x 1 w
	mm <sup>2</sup>	0.75 to 1 x 2 w
Ring terminal cap	0.8 Nm - 7 Lb/in	

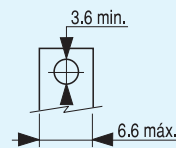

Fast-on 2.8 - 2 insulated terminals	mm <sup>2</sup>	1 x 2 w.
Terminal for printed circuit (Ø of PCB hole)	1.8mm	
Ring terminal cap	7.8mm	
Fork terminal cap	6.5mm	

### Coil Terminal capacity and tightening torque

Tightening torque	0.8Nm - 7Lb/in	
Solid wire	(mm <sup>2</sup> )	0.75 to 2x2
Flexible wire without terminal	(mm <sup>2</sup> )	0.75 to 2.5x2
Flexible wire without terminal with cap	(mm <sup>2</sup> )	0.75 to 2.5x21

## Control circuit

		MCRA...	MCRC...	MCRC...	MCRI...	MCRK...
Rated insulation voltage (Ui)	(V)	750	750	750	750	750
Standard voltages (Us)						
50Hz	(V)	24..690	-	-	-	-
60Hz	(V)	6..600	-	-	-	-
DC	(V)	-	6..440	12..440	24	24
Voltage <sup>(1)</sup>						
Operating limits	xUs	0.8..1.1	0.8..1.1	0.7..1.3	0.8..1.25	0.7..1.25
Drop-out	xUs	0.35..0.55	0.15..0.3	0.15..0.3	0.15..0.3	0.13..0.35
Consumption						
Pick-up	(VA)	26	-	-	-	-
Seal	(VA)	4	-	-	-	-
DC	(W)	-	3	4	1.2	2
Power factor						
Pick-up	(cos φ)	0.8	-	-	-	-
Seal	(cos φ)	0.35	-	-	-	-
Power dissipation	(W)	1.4	3	4	1.2	2
Opening and closing times						
Values between ± %Us	%	+10...-20	+10...-20	+30...-30	+25...-20	+25...-20
Time at energisation NO	(ms)	6..13	22..36	17..28	30..70	20..50
Time at de-energisation NC	(ms)	8..16	9..12	9..12	9..16	9..16
Time at energisation NC	(ms)	5..11	18..27	12..25	20..45	18..35
Time at de-energisation NO	(ms)	6..13	5..7	5..7	5..9	5..9
Values at Us						
Time at energisation NO	(ms)	7..12	24..27	19..23	25..45	25..40
Time at de-energisation NC	(ms)	8..16	9..11	9..11	9..16	9..16
Time at energisation NC	(ms)	6..10	20..26	15..21	25..35	20..30
Time at de-energisation NO	(ms)	6..13	5..8	5..8	5..9	5..9
Maximum time without voltage (without effecting the closed magnetic circuit)	(ms)	3	3	3	3	3
Mechanical endurance						
Monofrequency	x10 <sup>6</sup> ops.	15	-	-	-	-
Dual-frequency	x10 <sup>6</sup> ops.	10	-	-	-	-
DC	x10 <sup>6</sup> ops.	-	10	10	10	10
Maximum rate (no load)						
Monofrequency	n° ops./h	9000	-	-	-	-
Dual-frequency	n° ops./h	3600	-	-	-	-
DC	n° ops./h	-	9000	9000	9000	9000

## Contact sequence (distance in mm)

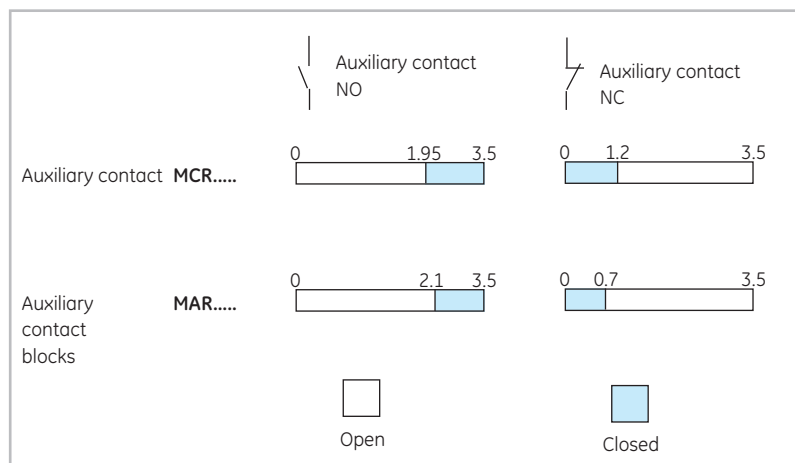

### Internal auxiliary contacts

		MCR.....	
Rated insulation voltage (Ui) acc. IEC 60947-1		750V	
Rated thermal current (Ith) $\theta \leq 60^\circ\text{C}$ [1]		16A	
Making capacity (r.m.s.) acc. IEC 60947-5			
AC-15	$U_e \leq 440\text{V } 50/60\text{Hz}$	160A	
DC-13	$U_e \leq 220\text{V DC}$	3A	
Breaking capacity (r.m.s.) acc. IEC 60947-5			
AC-15	$U_e \leq 440\text{V } 50/60\text{Hz}$	106A	
DC-13 (L/R = 100 ms)	$U_e \leq 220\text{V DC}$	1.2A	
	$U_e = 110\text{V DC}$	3A	
	$U_e = 48\text{V DC}$	10A	
Rated voltage and rated current $U_e$ - $I_e$			
AC-15	according to IEC 947	110/120V - 6A 220/240V - 6A 380/400V - 4A 415/440V - 4A 500V - 2.5A 660/690V - 1.5A	
	according to UL, CSA	A600	
	DC-13	according to IEC	24V - 5A 48V - 3.5 A 110V - 1.2A 220V - 0.6A 440V - 0.25A
		according to UL, CSA	P600
		Minimum operational power (operational safety)	
Short-circuit protection		10A	
(max.class gI fuse without welding)			
Insulation resistance			
	between contacts	> 10M $\Omega$	
	between contacts and earth	> 10M $\Omega$	
	between input and output	> 10M $\Omega$	
Guaranteed no overlap of the contacts			
	Space	1.1mm	
	minimum time	> 2ms	
Impedance		2.3m $\Omega$	
Terminal capacity		Same as main circuit	

### Tripping characteristics (AC)

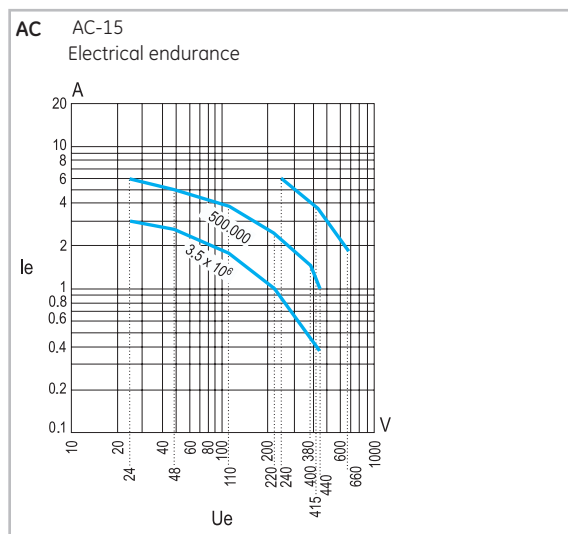

### Tripping characteristics $I_e/U_e$

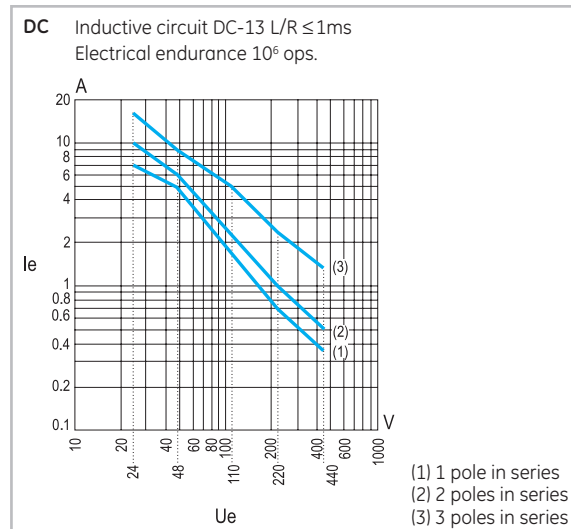
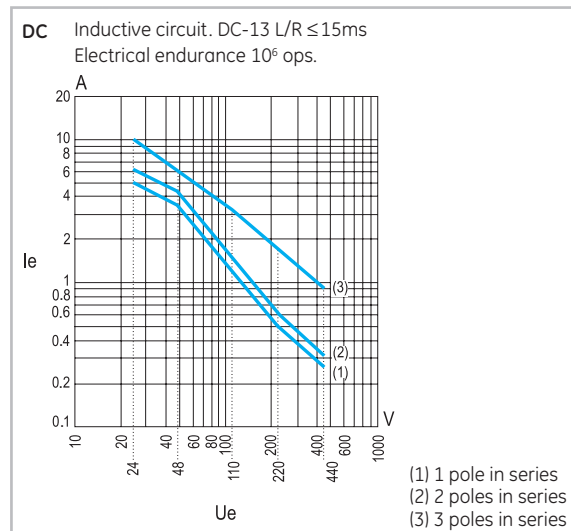
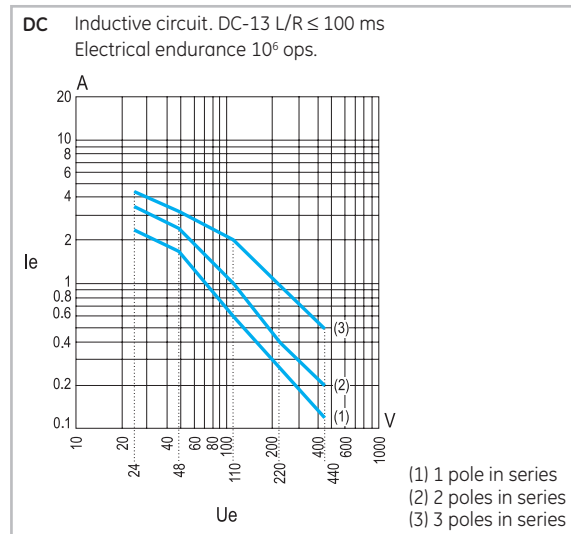

### External auxiliary contact blocks

MARN..., MARL...		
Rated insulation voltage (Ui) acc. IEC 60947-1		750V
Rated thermal current (Ith) $\theta \leq 60^\circ\text{C}^{(1)}$		10A
Making capacity (r.m.s.) acc. IEC 60947-5		
AC-15	Ue $\leq$ 220V 50/60Hz	73A
	Ue = 380V 50/60Hz	38A
	Ue = 690V 50/60Hz	22A
DC-13 L/R = 100 ms	Ue $\leq$ 100V DC	2.6A
	Ue = 220V DC	1A
	Ue = 440V DC	0.6A
Breaking capacity (r.m.s.) acc. IEC 60947-5		
AC-15	Ue $\leq$ 220V 50/60Hz	73A
	Ue = 380V 50/60Hz	38A
	Ue = 690V 50/60Hz	22A
DC-13 L/R = 100 ms	Ue $\leq$ 100V DC	2A
	Ue = 220V DC	0.8A
	Ue = 440V DC	0.4A
Rated voltage and rated current Ue-Ie		
AC-15	according to IEC 60947	110/120V - 6A
		220/240V - 6A
		380/400V - 3A
		415/440V - 3A
		500V - 1A
		660/680V - 1A
	according to UL, CSA	A600
DC-13	according to IEC 60947	24V - 4A
		48V - 2A
		110V - 0.7A
		220V - 0.3A
		440V - 0.1A
	according to UL, CSA	Q600
Minimum operational power (operational safety)		
		5mA, 17V
Short-circuit protection		
	(max.class g) fuse without welding	10A
Insulation resistance		
	between contacts	> 10M $\Omega$
	between contacts and earth	> 10M $\Omega$
	between input and output	> 10M $\Omega$
Guaranteed no overlap of the contacts		
	Space	0.5mm
	minimum time	> 2ms
Impedance		
		2.4m $\Omega$
Terminal capacity		
		Same as main circuit

### Tripping characteristics (AC)

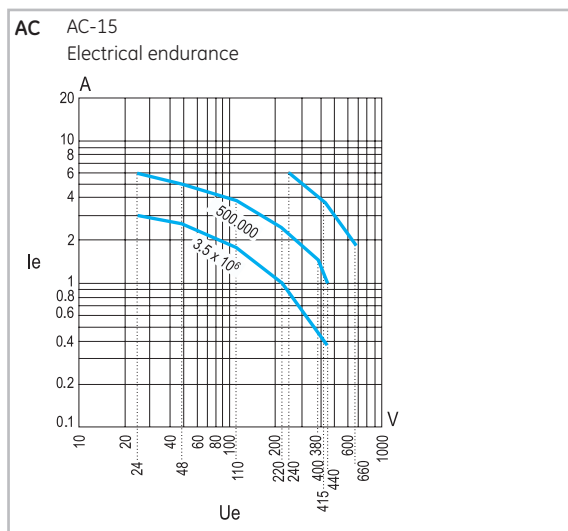

### Tripping characteristics Ie/ue

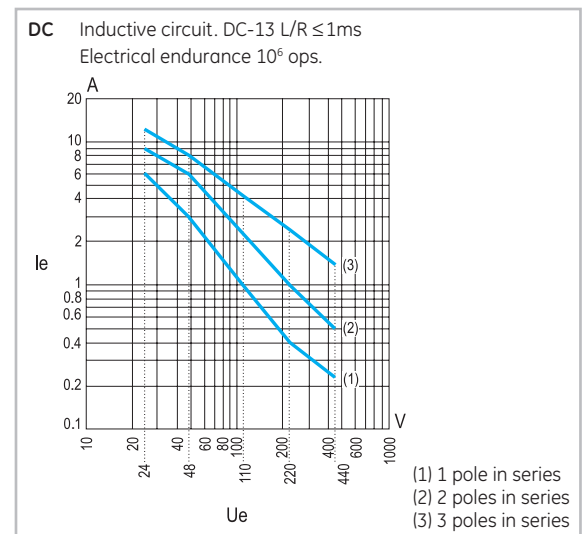
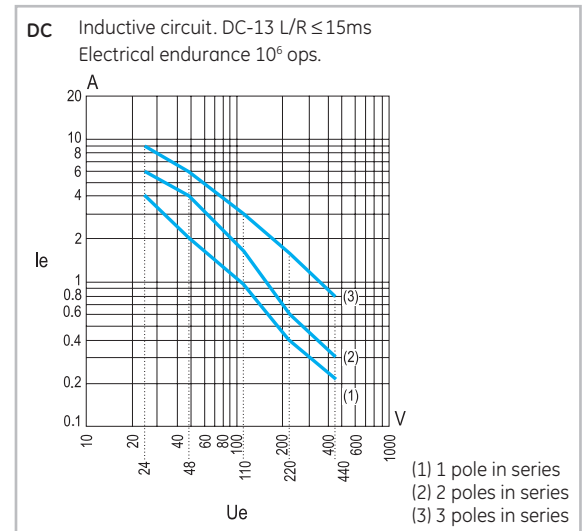
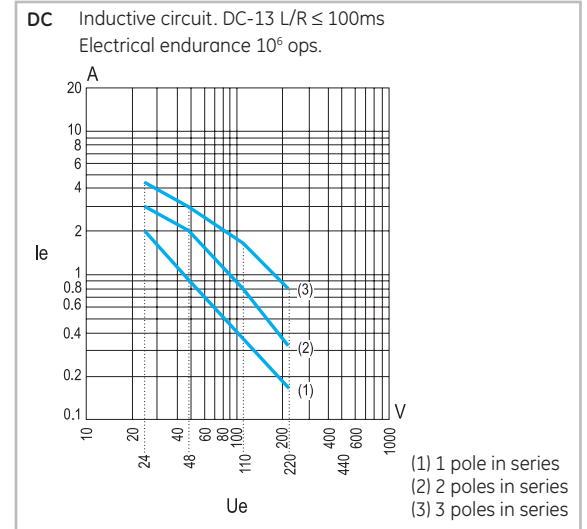

**Electronic timer block**

		MREBC...
Rated insulation voltage (Ui)		750V
Rated thermal current (Ith) $\theta \leq 60^{\circ}\text{C}$ <sup>(1)</sup>		0.55V
Standard voltages (AC y DC)		24 to 250V
Operation limits		0.80 to 1.1 Us (0.85 to 1.1 Us at 12V)
Voltage drop		< 3V
Maximum load current at		
	20°C	0.9A
	40°C	0.72A
	60°C	0.55A
Minimum load for safe operation		> 10mA
Maximum current (peak)		10A for 40ms
Leakage current at 220V		< 5mA
Operational current		
	AC-15	0.7A
	DC-13	0.9A
Timing range (delay ON)		0.5 to 60s ( $\pm 6\%$ )
Rearrangement time		< 100ms
Repeatability (accuracy)		$\pm 1\%$
Ambient temperature		
	Storage	from $-55$ up to $+80^{\circ}\text{C}$
	Operation	from $-5$ up to $+60^{\circ}\text{C}$
Degree of protection		IP20
Mounting position		any
Terminals : 2 free cables		1mm <sup>2</sup> (AWG 17) 250mm

MREBC\_0AC2

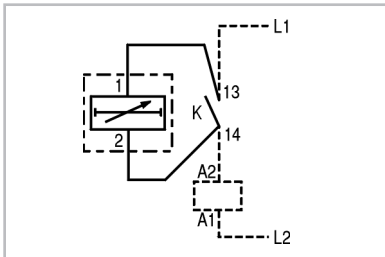

## Terminal numbering

### Auxiliary contactors. According to EN 50011

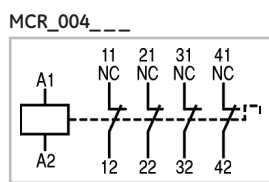
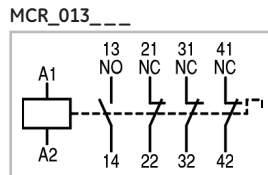
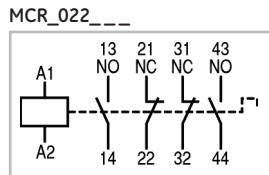
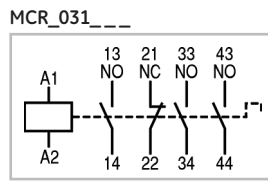
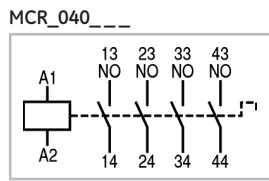

## Auxiliary contact blocks

According to EN 50005 & EN 50011

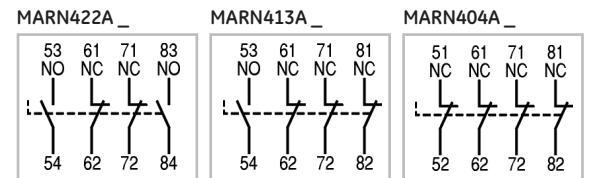
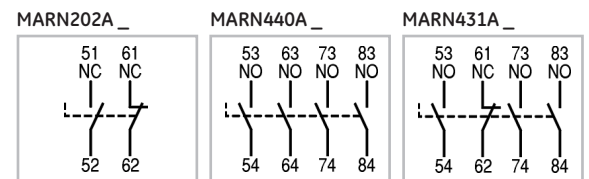
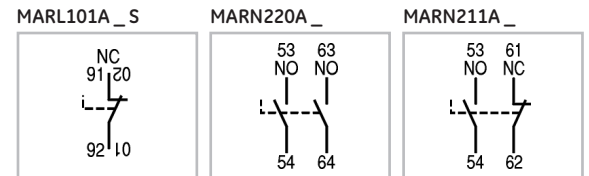
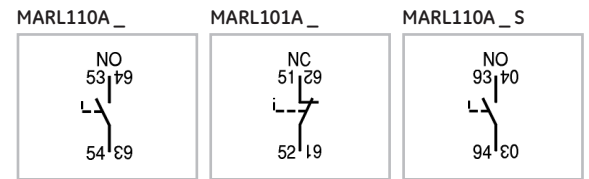

## Transient voltage suppressor block

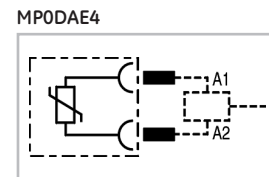
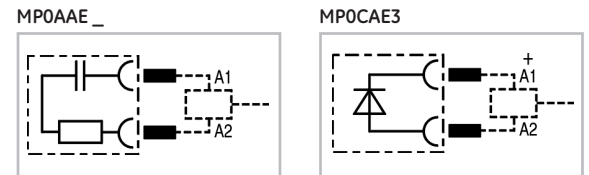







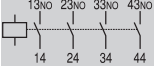
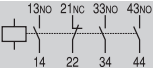
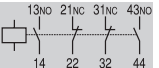
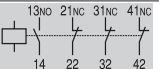
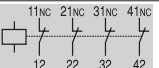

### Terminal numbering in accordance with EN 50011

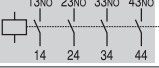
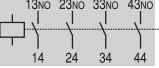
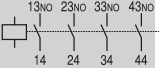
By combining other basic auxiliary contactors with auxiliary contact blocks MAR..., it is possible to obtain other combinations, and positions of contacts which are not covered by the table. But in all cases the maximum number of auxiliary contacts should be ten.

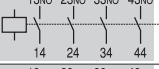
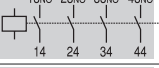
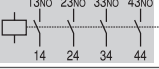
**Type E**

Standard contact combination in which the interchangeability of the devices does not affect the cabling or the diagram. Specifies a particular contact numbering and positioning.

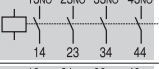
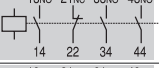
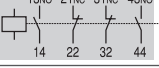
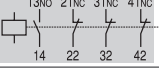
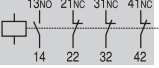
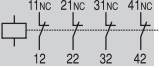
	Final structure of the combination	Auxiliary contacts		Auxiliary contactor + Auxiliary contact blocks to be added	
		Combination	NO NC		
Type E		Description			
		40E	4 0	MCRA040A..	
		31E	3 1	MCRA031A..	
		22E	2 2	MCRA022A..	
		13E	1 3	MCRA013A..	
		04E	0 4	MCRA004A..	
			60E	6 0	MCRA040A.. + MARN220A..
			51E	5 1	MCRA040A.. + MARN211A..
			42E	4 2	MCRA040A.. + MARN202A..
			80E	8 0	MCRA040A.. + MARN440A..
			71E	7 1	MCRA040A.. + MARN431A..
			62E	6 2	MCRA040A.. + MARN422A..
			53E	5 3	MCRA040A.. + MARN413A..
			44E	4 4	MCRA040A.. + MARN404A..
				50E	5 0
			41E	4 1	MCRA031A.. + MARL110A..
			32E	3 2	MCRA022A.. + MARL110A..
			23E	2 3	MCRA013A.. + MARL110A..
			14E	1 4	MCRA013A.. + MARL101A..
	05E		0 5	MCRA004A.. + MARL101A..	

## Terminal numbering in accordance with EN 50011 (continued)

By combining other basic auxiliary contactors with auxiliary contact blocks MAR..., it is possible to obtain other combinations, and positions of contacts which are not covered by the table. But in all cases the maximum number of auxiliary contacts should be ten.

### Type Z

Contact combination the same as Type E. Interchangeability of the devices may affect the cabling and the diagram. Neither contact numbering nor positioning are retained.

### Type X

Contact combination the same as Type E. Interchangeability of the devices may affect the cabling but not the diagram. The contact numbering is maintained but not their position.

### Type Y

Contact combination which differs from Type E, although it is obtained by a combination of devices provided for this Type E.

	Final structure of the combination	Auxiliary contacts		Auxiliary contactor + Auxiliary contact blocks to be added	
		Combination Description	NO NC		
Type Z			6 0	MCRA040A.. + MARL110A.. + MARL110A..	
			5 1	MCRA040A.. + MARL110A.. + MARL101A..	
			4 2	MCRA040A.. + MARL101A.. + MARL101A..	
			10 0	MCRA040A.. + MARN440A.. + MARL110A..S + MARL110A..S	
			5 5	MCRA040A.. + MARN413A.. + MARL101A..S + MARL101A..S	
	Type X			8 0	MCRA040A.. + MARL110A.. + MARL110A.. + MARL110A..S + MARL110A..S
			7 1	MCRA040A.. + MARL110A.. + MARL101A.. + MARL110A..S + MARL110A..S	
			6 2	MCRA040A.. + MARL110A.. + MARL101A.. + MARL101A..S + MARL110A..S	
			5 3	MCRA040A.. + MARL110A.. + MARL101A.. + MARL101A..S + MARL101A..S	
			4 4	MCRA040A.. + MARL101A.. + MARL101A.. + MARL101A..S + MARL101A..S	
			9 1	MCRA040A.. + MARN431A.. + MARL110A..S + MARL110A..S	
			8 2	MCRA040A.. + MARN431A.. + MARL101A..S + MARL110A..S	
			7 3	MCRA040A.. + MARN422A.. + MARL101A..S + MARL110A..S	
			6 4	MCRA040A.. + MARN422A.. + MARL101A..S + MARL101A..S	
Type Y				4 2	MCRA031A.. + MARL110A.. + MARL101A..
				3 3	MCRA022A.. + MARL110A.. + MARL101A..
				4 2	MCRA031A.. + MARN211A..
			3 3	MCRA022A.. + MARN211A..	
			5 3	MCRA031A.. + MARN422A..	
			4 4	MCRA022A.. + MARN422A..	

## Dimensional drawings

### Auxiliary minicontactors

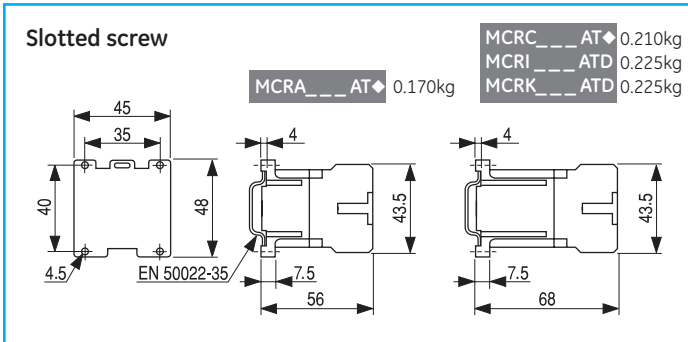

### Auxiliary contact blocks. Front mounting

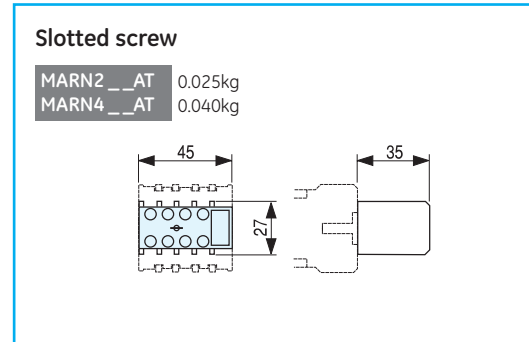

### Auxiliary contact blocks. Lateral mounting

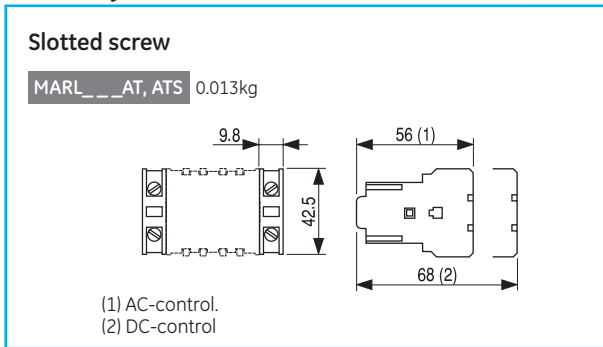

### Electronic timer block

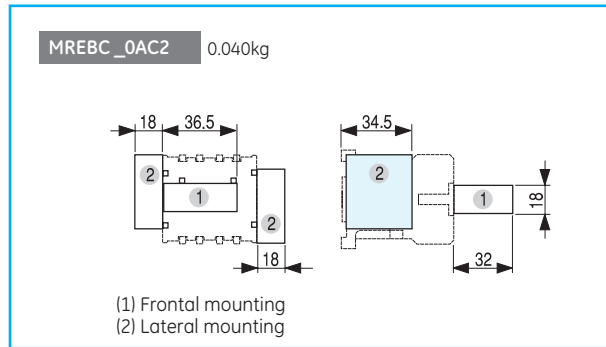

### Voltage suppressor block

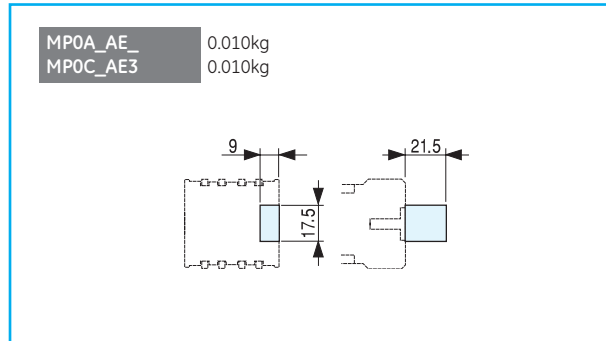

# Series RL

## General

Maximum number of contacts	4
Rated thermal current (I <sub>th</sub> ) θ < 55°C	20A
Rated operational voltage (U <sub>e</sub> )	690V
Insulation voltage (U <sub>i</sub> )	1000V

## Conformity to standards

IEC / EN 60947-1	IEC / EN 60947-5-1	ASE 1025
EN 50005	EN 50011	VDE 0660 / 102
NFC 63-110	NFC 63-140	
CENELEC HD 410	CENELEC HD 420	
NEMA ICS 1	CSA C22.2/14	
UL 508	BS 4794	

## Approvals/Marking

cULus	DEMKO	NEMKO
SEMKO	FI	CE
Lloyd's Register	Bureau Veritas	

## Ambient conditions

Storage temperature	-55°C to +80°C	
Operation temperature	-40°C to +60°C	
Altitude	up to 3000m	Nominal values
	from 3000 to 4000m	90%le 80%Ue
	from 4000 to 5000m	80%le 75%Ue

## Climatic resistance (IEC 68-2)

Continuous tests	40 / 125 / 56		
Cold (72h)	Temperature	-40°C	
	Relative humidity	< 50%	
	Relative humidity	< 50%	
Dry heat (96h)	Temperature	+125°C	
	Relative humidity	< 50%	
	Relative humidity	< 50%	
Humid heat (56 days)	Temperature	+40°C	
	Relative humidity	95%	
	Relative humidity	95%	
Cyclical tests (6 cycles)	Humid heat		
	First half-cycle (12h)	Low temperature	+25°C
		Relative humidity	93%
	Second half-cycle (12h)	Low temperature	+55°C
		Relative humidity	95%
		Relative humidity	95%

## Mounting positions

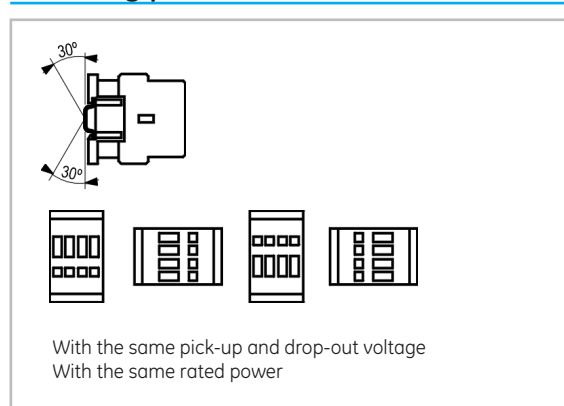

## Control circuit

		RL4RA...	RL4RD...	RL4RD...W
Rated insulation voltage U <sub>i</sub>	(V)	1000	1000	1000
Standard voltages U <sub>s</sub>				
50Hz (V)		24 ... 690	-	-
60Hz (V)		24 ... 600	-	-
DC	(V)	-	12 ... 440	12 ... 440
Voltage <sup>[1]</sup>				
Operating limits	xU <sub>s</sub>	0.8 ... 1.1	0.8 ... 1.1	0.7 ... 1.3
Pick-up	xU <sub>s</sub>	0.65 ... 0.75	0.45 ... 0.65	0.45 ... 0.55
Seal	xU <sub>s</sub>	0.4 ... 0.55	0.15 ... 0.3	0.15 ... 0.3
Consumption				
AC	Magnetic circuit closed	(VA)	6	-
	Magnetic circuit open	(VA)	45	-
DC	Magnetic circuit closed	(W)	-	5.5
	Magnetic circuit open	(W)	-	5.5
Power dissipation	(W)	2.4	5.5	6.5
Power factor				
Magnetic circuit closed	cos φ	0.34	-	-
Magnetic circuit open	cos φ	0.82	-	-
Opening and closing times				
at 0.8 to 1.1 U <sub>s</sub>				
Closing time NO	(ms)	6 ... 25	35 ... 65	25 ... 65
Opening time NO	(ms)	6 ... 13	6 ... 13	6 ... 13
at U <sub>s</sub>				
Closing time NO	(ms)	8 ... 20	35 ... 45	25 ... 55
Opening time NO	(ms)	6 ... 13	7 ... 12	6 ... 13
Mechanical endurance	10 <sup>6</sup> ops	15	15	15
Maximum rate no load	ops/h	9000	3600	3600

## Contact sequence (distance in mm)

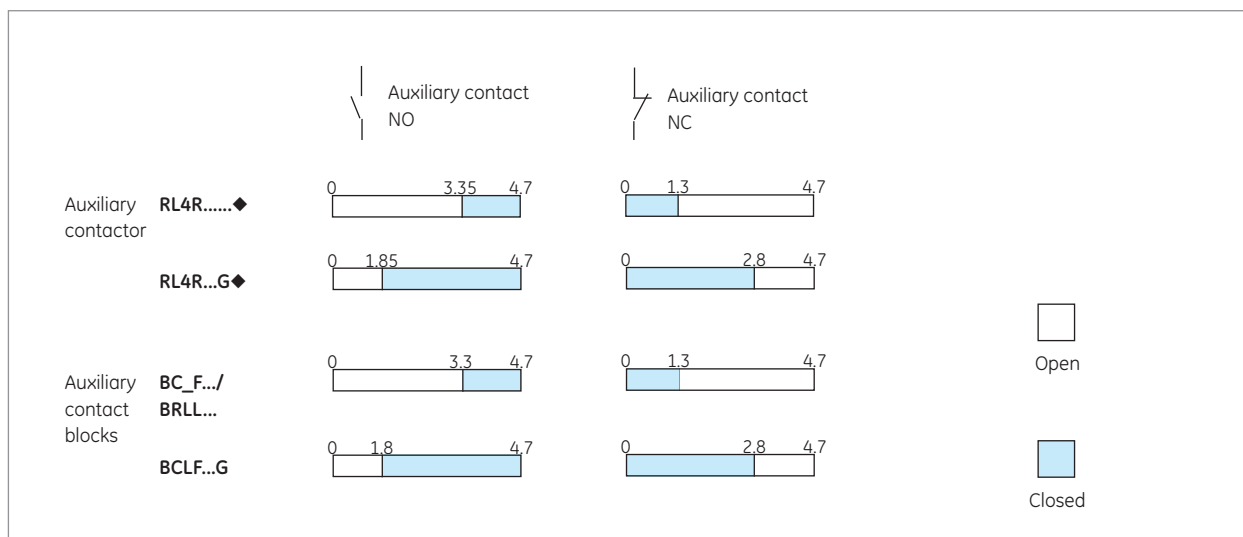

### Internal auxiliary contacts

	RL4.....
Rated insulation voltage (Ui) acc. IEC 60947-5	1000V
Rated thermal current (Ith) $\theta < 55^{\circ}\text{C}$	20A
Making capacity (r.m.s.) acc. IEC 60947-5	
AC-15 $U_e \leq 400\text{V}, 50/60\text{Hz}$	250A
DC-13 $U_e \leq 220\text{V DC}$	250A
Breaking capacity (r.m.s.) acc. IEC 60947-5	
AC-15 $U_e \leq 400\text{V}, 50/60\text{Hz}$	250A
DC-13 $U_e \leq 220\text{V DC}$	2A (4A with 2 contacts in series)
$U_e \leq 110\text{V DC}$	7A (12A with 2 contacts in series)
$U_e \leq 48\text{V DC}$	10A (18A with 2 contacts in series)
Rated voltage and rated current $U_e\text{-I}_e$	
AC-15 according to IEC	110/120V - 10A 220/240V - 10A 380/400V - 6A 415/440V - 5A 500V - 4A 660/690V - 2A
according to UL, CSA	A600
DC-13 according to IEC	24V - 6A 48V - 4A 110V - 2A 220V - 0.7A 440V - 0.35A
according to UL, CSA	P600
Electrical endurance	$1 \times 10^6$ ops.
Minimum operational voltage (operational safety)	17V
Minimum operational current	5mA
Short-circuit protection	
max. fus. class gL fuse	20A
without welding	10A
Insulation resistance	
between contacts	$> 10\text{m}\Omega$
between contacts and earth	$> 10\text{m}\Omega$
between input and output	$> 10\text{m}\Omega$
Guaranteed no overlap between NO and NC contacts	
space	1.3mm
minimum time	1.5ms
Impedance	1.28m $\Omega$

### Terminal capacity

Solid, stranded and finely stranded without end sleeve	mm <sup>2</sup>	2x0.5 to 6
Finely stranded with end sleeve	mm <sup>2</sup>	2x1 to 6
AWG wires, solid and stranded	mm <sup>2</sup>	2x20 to 12
Tightening torque		1.1 Nm / 10 Lb.in
Ring terminals		1.6 Nm / 15 Lb.in

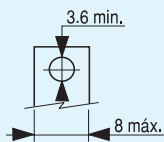

### Coil Terminal capacity and tightening torque

Tightening torque		0.8Nm - 7Lb/in
Solid wire	(mm <sup>2</sup> )	0.75 to 2x2
Flexible wire without terminal	(mm <sup>2</sup> )	0.75 to 2.5x2
Flexible wire without terminal with cap	(mm <sup>2</sup> )	0.75 to 2.5x21

### Instantaneous auxiliary contact blocks

	BCLF../BCRF../BRLL..
Rated insulation voltage (Ui) acc. IEC 60947-5	1000V
Rated thermal current (Ith) $\theta < 55^{\circ}\text{C}$	10A
Making capacity (r.m.s.) acc. IEC 60947-5	
AC-15 $U_e \leq 440\text{V}, 50/60\text{Hz}$	90A
DC-13 $U_e \leq 220\text{V DC}$	90A
Breaking capacity (r.m.s.) acc. IEC 60947-5	
AC-15 $U_e \leq 400\text{V}, 50/60\text{Hz}$	60A
DC-13 $U_e \leq 220\text{V DC}$	0.95A
Rated voltage and rated current $U_e\text{-I}_e$	
AC-15 according to IEC	110/120V - 6A 220/240V - 6A 380/400V - 4A 415/440V - 3.5A 500V - 2.5A 660/690V - 1.5A
according to UL, CSA	A600
DC-13	24V - 4A 48V - 2A 110V - 0.7A 220V - 0.3A 415/440V - 0.15A
according to UL, CSA	Q600
Electrical endurance	$1 \times 10^6$ ops.
Minimum operational voltage (operational safety)	17V
Minimum operational current	5mA
Short-circuit protection (without welding) gL	10A
Insulation resistance	
between contacts	$> 10\text{m}\Omega$
between contacts and earth	$> 10\text{m}\Omega$
between input and output	$> 10\text{m}\Omega$
Guaranteed no overlap between NO and NC contacts	
Space	1.3mm
minimum time	1.5ms
Impedance of the contacts	1.28m $\Omega$

### Terminal capacity

Solid, stranded and finely stranded without end sleeve	mm <sup>2</sup>	2x0.5 to 2.5 2x2.5 to 4
Finely stranded with end sleeve	mm <sup>2</sup>	2x0.5 to 2.5 2x2.5 to 4
AWG wires, solid and stranded	mm <sup>2</sup>	2x20 to 10
Tightening torque		0.8 Nm / 7 Lb.in
Ring terminals		0.8 Nm / 7 Lb.in

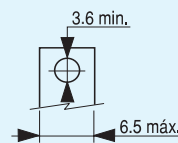

## Timed auxiliary contact blocks

		BTLF... / BTRF...
Rated insulation voltage (Ui) acc. IEC 60947-5		1000V
Rated thermal current (Ith) $\theta < 55^{\circ}\text{C}$		10A
Making capacity (r.m.s.) acc. IEC 60947-5		
AC-15	$U_e \leq 440\text{V}, 50/60\text{Hz}$	90A
DC-13	$U_e \leq 220\text{V DC}$	90A
Breaking capacity (r.m.s.) acc. IEC 60947-5		
AC-15	$U_e \leq 400\text{V}, 50/60\text{Hz}$	60A
DC-13	$U_e \leq 220\text{V DC}$	0.95A
Rated voltage and rated current $U_e$ - $I_e$		
AC-15	according to IEC	110/120V - 6A 220/240V - 6A 380/400V - 4A 415/440V - 3.5A 500V - 2.5A 660/690V - 1.5A
	according to UL, CSA	A600
DC-13	according to IEC	24V - 4A 48V - 2A 110V - 0.7A 220V - 0.3A 415/440V - 0.15A
	according to UL, CSA	Q600
Electrical endurance		$1 \times 10^6$ ops.
Minimum operational voltage (operational safety)		17V
Minimum operational current		5mA
Short-circuit protection (without welding) gL		10A
Insulation resistance		
	between contacts	$> 10\text{m}\Omega$
	between contacts and earth	$> 10\text{m}\Omega$
	between input and output	$> 10\text{m}\Omega$
Guaranteed no overlap between NO and NC contacts		
	space	1.3mm
	minimum time	1.5ms
Timing		
(Ambient temperature between $-25$ and $+55^{\circ}\text{C}$ )		
	Accuracy	$\pm 5\%$
	Loss of accuracy after $0.5 \times 10^6$ ops.	+ 20%
	Loss of accuracy per rise $^{\circ}\text{C}$ ( $0 - 55^{\circ}\text{C}$ )	+ 0.75 % per $^{\circ}\text{C}$
Impedance of the contacts		1.28m $\Omega$
Mechanical endurance		$5 \times 10^6$ ops.
Peak current		
	during 1 s.	50A
	during 0.1 s.	100A

## Terminal capacity

Solid, stranded and finely stranded without end sleeve	(mm <sup>2</sup> )	2x0.5 to 2.5 2x2.5 to 4
Finely stranded with end sleeve	(mm <sup>2</sup> )	2x0.5 to 2.5 2x2.5 to 4
AWG wires, solid and stranded	(mm <sup>2</sup> )	2x20 to 10
Tightening torque		0.8 Nm / 7 Lb.in
Ring terminals		0.8 Nm / 7 Lb.in

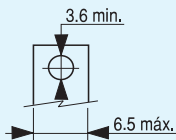

## Mechanical latch blocks

		RMLF.....
Rated insulation voltage (Ui)		1000V
Standard voltages (Us); 50-60Hz and direct current		24 ... 690V
Operating limits		0.75 to 1.1 xUs
Consumption for unlatching (auto cut-out)		210W /VA (24-72V) 130W /VA (110-440V)
Unlatching control <sup>(1)</sup>		
Electrical	Min.impuls	10 ms Maintained auto cut-out by integral contact 55-56 (only AC slots)
Manual		By local (0) push-button
Contactor control		
Electrical	Min.impuls	40 ms
Manual		By local (I) push-button
Mechanical endurance RL4		$3 \times 10^6$ (1200ops./h)

## Terminal capacity

Solid, stranded and finely stranded without end sleeve	mm <sup>2</sup>	2x0.5 to 2.5 2x2.5 to 4
Finely stranded with end sleeve	mm <sup>2</sup>	2x0.5 to 2.5 2x2.5 to 4
AWG wires, solid and stranded	mm <sup>2</sup>	2x20 to 10
Tightening torque		0.8 Nm / 7 Lb.in

**Terminal numbering**

*Auxiliary contactors*

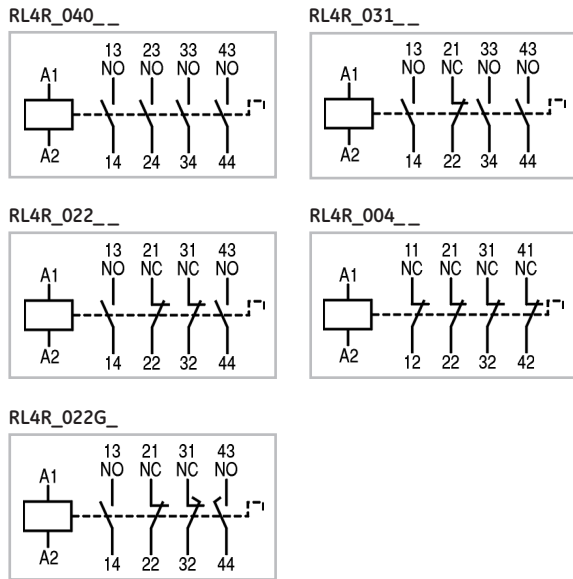

*Auxiliary contact blocks. Front mounting*

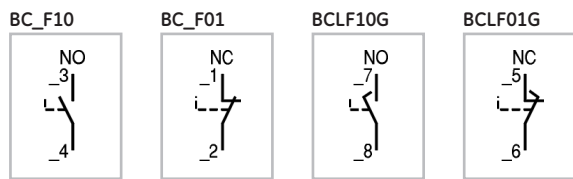

*Auxiliary contact blocks. Lateral mounting*

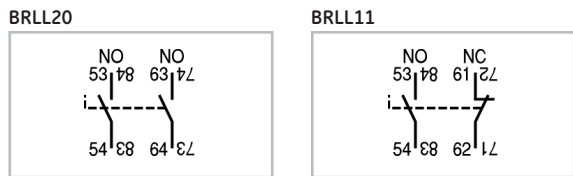

*Pneumatic timer blocks*

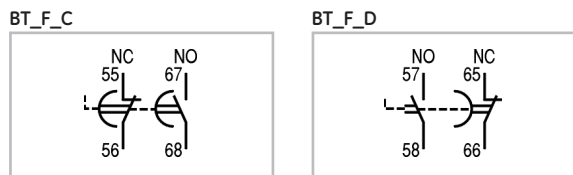

*Electronic timer blocks*

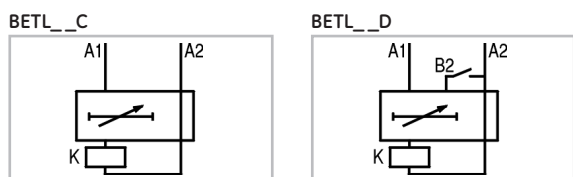

*Mechanical (-/electrical) interlock*

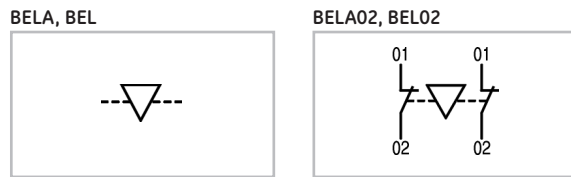

*Mechanical latch block*

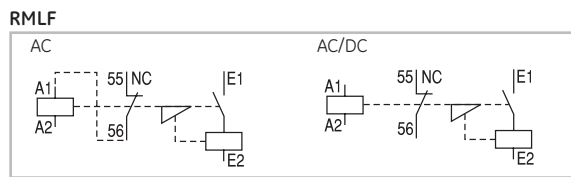

*Voltage suppressor blocks*

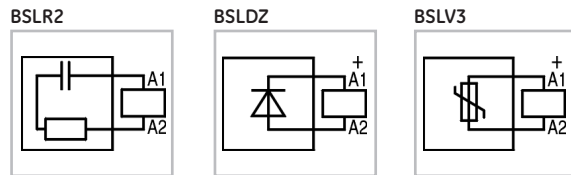



















## Terminal numbering in accordance with EN 50011

By combining other basic auxiliary contactors with auxiliary contact blocks BLC..., it is possible to obtain other combinations, and positions of contacts which are not covered by the table. But in all cases the maximum number of additional auxiliary contacts should be four.

### Type E

Standard contact combination in which the interchangeability of the devices does not affect the cabling or the diagram. Specifies a particular contact numbering and positioning.















Type	Final structure of the combination	Auxiliary contacts		Auxiliary contactor +Auxiliary contact blocks to be added																			
		Combination Description	NO NC																				
Type E	 <table border="1"> <tr><td>A1</td><td>13NO</td><td>23NO</td><td>33NO</td><td>43NO</td></tr> <tr><td>A2</td><td>14</td><td>24</td><td>34</td><td>44</td></tr> </table>	A1	13NO	23NO	33NO	43NO	A2	14	24	34	44	40E	4	0	RL4RA040...								
	A1	13NO	23NO	33NO	43NO																		
	A2	14	24	34	44																		
	 <table border="1"> <tr><td>A1</td><td>13NO</td><td>21NC</td><td>33NO</td><td>43NO</td></tr> <tr><td>A2</td><td>14</td><td>22</td><td>34</td><td>44</td></tr> </table>	A1	13NO	21NC	33NO	43NO	A2	14	22	34	44	31E	3	1	RL4RA031...								
	A1	13NO	21NC	33NO	43NO																		
	A2	14	22	34	44																		
	 <table border="1"> <tr><td>A1</td><td>13NO</td><td>21NC</td><td>31NC</td><td>43NO</td></tr> <tr><td>A2</td><td>14</td><td>22</td><td>32</td><td>44</td></tr> </table>	A1	13NO	21NC	31NC	43NO	A2	14	22	32	44	22E	2	2	RL4RA022...								
	A1	13NO	21NC	31NC	43NO																		
	A2	14	22	32	44																		
	 <table border="1"> <tr><td>A1</td><td>11NC</td><td>21NC</td><td>31NC</td><td>41NC</td></tr> <tr><td>A2</td><td>12</td><td>22</td><td>32</td><td>42</td></tr> </table>	A1	11NC	21NC	31NC	41NC	A2	12	22	32	42	04E	0	4	RL4RA004...								
	A1	11NC	21NC	31NC	41NC																		
	A2	12	22	32	42																		
 <table border="1"> <tr><td>A1</td><td>13NO</td><td>23NO</td><td>33NO</td><td>43NO</td><td>53NO</td></tr> <tr><td>A2</td><td>14</td><td>24</td><td>34</td><td>44</td><td>54</td></tr> </table>	A1	13NO	23NO	33NO	43NO	53NO	A2	14	24	34	44	54	50E	5	0	RL4RA040... + BC_F10							
	A1	13NO	23NO	33NO	43NO	53NO																	
	A2	14	24	34	44	54																	
	 <table border="1"> <tr><td>A1</td><td>13NO</td><td>21NC</td><td>33NO</td><td>43NO</td><td>53NO</td></tr> <tr><td>A2</td><td>14</td><td>22</td><td>34</td><td>44</td><td>54</td></tr> </table>	A1	13NO	21NC	33NO	43NO	53NO	A2	14	22	34	44	54	41E	4	1	RL4RA031... + BC_F10						
	A1	13NO	21NC	33NO	43NO	53NO																	
	A2	14	22	34	44	54																	
 <table border="1"> <tr><td>A1</td><td>13NO</td><td>21NC</td><td>31NC</td><td>43NO</td><td>53NO</td></tr> <tr><td>A2</td><td>14</td><td>22</td><td>32</td><td>44</td><td>54</td></tr> </table>	A1	13NO	21NC	31NC	43NO	53NO	A2	14	22	32	44	54	32E	3	2	RL4RA022... + BC_F10							
A1	13NO	21NC	31NC	43NO	53NO																		
A2	14	22	32	44	54																		
 <table border="1"> <tr><td>A1</td><td>13NO</td><td>21NC</td><td>31NC</td><td>43NO</td><td>51NC</td></tr> <tr><td>A2</td><td>14</td><td>22</td><td>32</td><td>44</td><td>52</td></tr> </table>	A1	13NO	21NC	31NC	43NO	51NC	A2	14	22	32	44	52	23E	2	3	RL4RA022... + BC_F01							
A1	13NO	21NC	31NC	43NO	51NC																		
A2	14	22	32	44	52																		
 <table border="1"> <tr><td>A1</td><td>11NC</td><td>21NC</td><td>31NC</td><td>41NC</td><td>53NO</td></tr> <tr><td>A2</td><td>12</td><td>22</td><td>32</td><td>42</td><td>54</td></tr> </table>	A1	11NC	21NC	31NC	41NC	53NO	A2	12	22	32	42	54	14E	1	4	RL4RA004... + BC_F10							
A1	11NC	21NC	31NC	41NC	53NO																		
A2	12	22	32	42	54																		
 <table border="1"> <tr><td>A1</td><td>11NC</td><td>21NC</td><td>31NC</td><td>41NC</td><td>51NC</td></tr> <tr><td>A2</td><td>12</td><td>22</td><td>32</td><td>42</td><td>52</td></tr> </table>	A1	11NC	21NC	31NC	41NC	51NC	A2	12	22	32	42	52	05E	0	5	RL4RA004... + BC_F01							
A1	11NC	21NC	31NC	41NC	51NC																		
A2	12	22	32	42	52																		
 <table border="1"> <tr><td>A1</td><td>13NO</td><td>23NO</td><td>33NO</td><td>43NO</td><td>53NO</td></tr> <tr><td>A2</td><td>14</td><td>24</td><td>34</td><td>44</td><td>54</td></tr> </table>	A1	13NO	23NO	33NO	43NO	53NO	A2	14	24	34	44	54	60E	6	0	RL4RA040... + BC_F10 + BC_F10							
	A1	13NO	23NO	33NO	43NO	53NO																	
	A2	14	24	34	44	54																	
 <table border="1"> <tr><td>A1</td><td>13NO</td><td>23NO</td><td>33NO</td><td>43NO</td><td>53NO</td><td>61NC</td></tr> <tr><td>A2</td><td>14</td><td>24</td><td>34</td><td>44</td><td>54</td><td>62</td></tr> </table>	A1	13NO	23NO	33NO	43NO	53NO	61NC	A2	14	24	34	44	54	62	51E	5	1	RL4RA040... + BC_F10 + BC_F01					
A1	13NO	23NO	33NO	43NO	53NO	61NC																	
A2	14	24	34	44	54	62																	
 <table border="1"> <tr><td>A1</td><td>13NO</td><td>23NO</td><td>33NO</td><td>43NO</td><td>51NC</td><td>61NC</td></tr> <tr><td>A2</td><td>14</td><td>24</td><td>34</td><td>44</td><td>52</td><td>62</td></tr> </table>	A1	13NO	23NO	33NO	43NO	51NC	61NC	A2	14	24	34	44	52	62	42E	4	2	RL4RA040... + BC_F01 + BC_F01					
A1	13NO	23NO	33NO	43NO	51NC	61NC																	
A2	14	24	34	44	52	62																	
 <table border="1"> <tr><td>A1</td><td>13NO</td><td>23NO</td><td>33NO</td><td>43NO</td><td>53NO</td><td>63NO</td><td>73NO</td><td>83NO</td></tr> <tr><td>A2</td><td>14</td><td>24</td><td>34</td><td>44</td><td>54</td><td>64</td><td>74</td><td>84</td></tr> </table>	A1	13NO	23NO	33NO	43NO	53NO	63NO	73NO	83NO	A2	14	24	34	44	54	64	74	84	80E	8	0	RL4RA040... + BC_F10 + BC_F10 + BC_F10 + BC_F10	
	A1	13NO	23NO	33NO	43NO	53NO	63NO	73NO	83NO														
	A2	14	24	34	44	54	64	74	84														
	 <table border="1"> <tr><td>A1</td><td>13NO</td><td>23NO</td><td>33NO</td><td>43NO</td><td>53NO</td><td>61NC</td><td>73NO</td><td>83NO</td></tr> <tr><td>A2</td><td>14</td><td>24</td><td>34</td><td>44</td><td>54</td><td>62</td><td>74</td><td>84</td></tr> </table>	A1	13NO	23NO	33NO	43NO	53NO	61NC	73NO	83NO	A2	14	24	34	44	54	62	74	84	71E	7	1	RL4RA040... + BC_F10 + BC_F01 + BC_F10 + BC_F10
	A1	13NO	23NO	33NO	43NO	53NO	61NC	73NO	83NO														
A2	14	24	34	44	54	62	74	84															
 <table border="1"> <tr><td>A1</td><td>13NO</td><td>23NO</td><td>33NO</td><td>43NO</td><td>53NO</td><td>61NC</td><td>71NC</td><td>83NO</td></tr> <tr><td>A2</td><td>14</td><td>24</td><td>34</td><td>44</td><td>54</td><td>62</td><td>72</td><td>84</td></tr> </table>	A1	13NO	23NO	33NO	43NO	53NO	61NC	71NC	83NO	A2	14	24	34	44	54	62	72	84	62E	6	2	RL4RA040... + BC_F10 + BC_F01 + BC_F01 + BC_F10	
A1	13NO	23NO	33NO	43NO	53NO	61NC	71NC	83NO															
A2	14	24	34	44	54	62	72	84															
 <table border="1"> <tr><td>A1</td><td>13NO</td><td>23NO</td><td>33NO</td><td>43NO</td><td>53NO</td><td>61NC</td><td>71NC</td><td>81NC</td></tr> <tr><td>A2</td><td>14</td><td>24</td><td>34</td><td>44</td><td>54</td><td>62</td><td>72</td><td>82</td></tr> </table>	A1	13NO	23NO	33NO	43NO	53NO	61NC	71NC	81NC	A2	14	24	34	44	54	62	72	82	53E	5	3	RL4RA040... + BC_F10 + BC_F01 + BC_F01 + BC_F01	
A1	13NO	23NO	33NO	43NO	53NO	61NC	71NC	81NC															
A2	14	24	34	44	54	62	72	82															
 <table border="1"> <tr><td>A1</td><td>13NO</td><td>23NO</td><td>33NO</td><td>43NO</td><td>51NC</td><td>61NC</td><td>71NC</td><td>81NC</td></tr> <tr><td>A2</td><td>14</td><td>24</td><td>34</td><td>44</td><td>52</td><td>62</td><td>72</td><td>82</td></tr> </table>	A1	13NO	23NO	33NO	43NO	51NC	61NC	71NC	81NC	A2	14	24	34	44	52	62	72	82	44E	4	4	RL4RA040... + BC_F01 + BC_F01 + BC_F01 + BC_F01	
A1	13NO	23NO	33NO	43NO	51NC	61NC	71NC	81NC															
A2	14	24	34	44	52	62	72	82															

Terminal numbering in accordance with EN 50011 (continued)

By combining other basic auxiliary contactors with auxiliary contact blocks BLC..., it is possible to obtain other combinations, and positions of contacts which are not covered by the table. But in all cases the maximum number of additional auxiliary contacts should be four.

**Type Z**  
 Contact combination the same as Type E.  
 Interchangeability of the devices may affect the cabling and the diagram. Neither contact numbering nor positioning are retained.

**Type Y**  
 Contact combination which differs from Type E, although it is obtained by a combination of devices provided for this Type E.

	Final structure of the combination	Auxiliary contacts		Auxiliary contactor +Auxiliary contact blocks to be added
		Combination	NO NC	
		Description		
Type Z	 <div style="display: flex; justify-content: space-around; font-size: 8px;"> <span>A1 13NO 23NO 33NO 43NO 53NO 63NO</span> </div> <div style="display: flex; justify-content: space-around; font-size: 8px;"> <span>A2 14 24 34 44 54 64</span> </div>	60Z	6 0	RL4RA040... + BRL20
	 <div style="display: flex; justify-content: space-around; font-size: 8px;"> <span>A1 13NO 23NO 33NO 43NO 53NO 61NC</span> </div> <div style="display: flex; justify-content: space-around; font-size: 8px;"> <span>A2 14 24 34 44 54 62</span> </div>	51Z	5 1	RL4RA040... + BRL11
	 <div style="display: flex; justify-content: space-around; font-size: 8px;"> <span>A1 13NO 23NO 33NO 43NO 53NO 63NO 73NO 83NO</span> </div> <div style="display: flex; justify-content: space-around; font-size: 8px;"> <span>A2 14 24 34 44 54 64 74 84</span> </div>	80Z	8 0	RL4RA040... + BRL20 + BRL20
	 <div style="display: flex; justify-content: space-around; font-size: 8px;"> <span>A1 13NO 23NO 33NO 43NO 53NO 61NC 73NO 83NO</span> </div> <div style="display: flex; justify-content: space-around; font-size: 8px;"> <span>A2 14 24 34 44 54 62 74 84</span> </div>	71Z	7 1	RL4RA040... + BRL11 + BRL20
	 <div style="display: flex; justify-content: space-around; font-size: 8px;"> <span>A1 13NO 23NO 33NO 43NO 53NO 61NC 71NC 83NO</span> </div> <div style="display: flex; justify-content: space-around; font-size: 8px;"> <span>A2 14 24 34 44 54 62 72 84</span> </div>	62Z	6 2	RL4RA040... + BRL11 + BRL11
	Type Y	 <div style="display: flex; justify-content: space-around; font-size: 8px;"> <span>A1 13NO 21NC 33NO 43NO 53NO 61NC</span> </div> <div style="display: flex; justify-content: space-around; font-size: 8px;"> <span>A2 14 22 34 44 54 62</span> </div>	42Y	4 2
 <div style="display: flex; justify-content: space-around; font-size: 8px;"> <span>A1 13NO 21NC 33NO 43NO 53NO 61NC</span> </div> <div style="display: flex; justify-content: space-around; font-size: 8px;"> <span>A2 14 22 34 44 54 62</span> </div>		42Y	4 2	RL4RA031... + BRL11
 <div style="display: flex; justify-content: space-around; font-size: 8px;"> <span>A1 13NO 21NC 33NO 43NO 53NO 61NC 71NC 83NO</span> </div> <div style="display: flex; justify-content: space-around; font-size: 8px;"> <span>A2 14 22 34 44 54 62 72 84</span> </div>		53Y	5 3	RL4RA031... + BC_F10 + BC_F01 + BC_F01 + BC_F10
 <div style="display: flex; justify-content: space-around; font-size: 8px;"> <span>A1 13NO 21NC 31NC 43NO 53NO 61NC 71NC 83NO</span> </div> <div style="display: flex; justify-content: space-around; font-size: 8px;"> <span>A2 14 22 32 44 54 62 72 84</span> </div>		44Y	4 4	RL4RA022... + BC_F10 + BC_F01 + BC_F01 + BC_F10
 <div style="display: flex; justify-content: space-around; font-size: 8px;"> <span>A1 13NO 21NC 31NC 43NO 53NO 61NC</span> </div> <div style="display: flex; justify-content: space-around; font-size: 8px;"> <span>A2 14 22 32 44 54 62</span> </div>		33Y	3 3	RL4RA022... + BC_F10 + BC_F01
 <div style="display: flex; justify-content: space-around; font-size: 8px;"> <span>A1 13NO 21NC 31NC 43NO 53NO 61NC</span> </div> <div style="display: flex; justify-content: space-around; font-size: 8px;"> <span>A2 14 22 32 44 54 62</span> </div>		33Y	3 3	RL4RA022... + BRL11
 <div style="display: flex; justify-content: space-around; font-size: 8px;"> <span>A1 13NO 23NO 33NO 43NO 55NC 67NO 73NO 83NO</span> </div> <div style="display: flex; justify-content: space-around; font-size: 8px;"> <span>A2 14 24 34 44 56 68 74 84</span> </div>				RL4RA040... + BTLF...C + BRL20
 <div style="display: flex; justify-content: space-around; font-size: 8px;"> <span>A1 13NO 23NO 33NO 43NO 57NO 65NC 73NO 83NO</span> </div> <div style="display: flex; justify-content: space-around; font-size: 8px;"> <span>A2 14 24 34 44 58 66 74 84</span> </div>				RL4RA040... + BTLF...D + BRL20
 <div style="display: flex; justify-content: space-around; font-size: 8px;"> <span>A1 13NO 23NO 33NO 43NO 55NC 67NO 71NC 83NO</span> </div> <div style="display: flex; justify-content: space-around; font-size: 8px;"> <span>A2 14 24 34 44 56 68 72 84</span> </div>				RL4RA040... + BTLF...C + BRL11
 <div style="display: flex; justify-content: space-around; font-size: 8px;"> <span>A1 13NO 23NO 33NO 43NO 57NO 65NC 71NC 83NO</span> </div> <div style="display: flex; justify-content: space-around; font-size: 8px;"> <span>A2 14 24 34 44 58 66 72 84</span> </div>				RL4RA040... + BTLF...D + BRL11

Technical data

Intro

A

B

C

D

E



## Dimensional drawings

### Auxiliary contactors

Screw terminal

AC

RL4RA\_\_\_T◆ 0.280kg

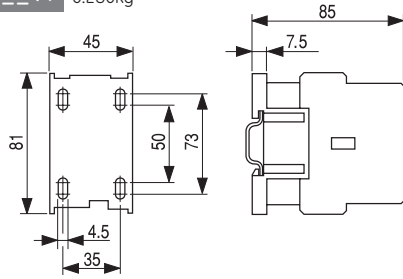

Ring terminal

AC

RL4RA\_\_\_R◆ 0.280kg

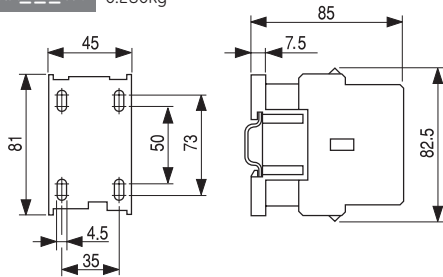

### Instantaneous auxiliary contact blocks

Screw terminal

Instantaneous, frontal mounting

BCLF\_\_\_ 0.015kg

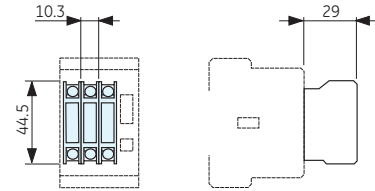

Screw terminal

Instantaneous, lateral mounting

BRLL\_\_\_ 0.048kg

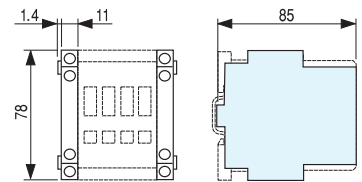

DC

RL4RD\_\_\_T◆ 0.490kg

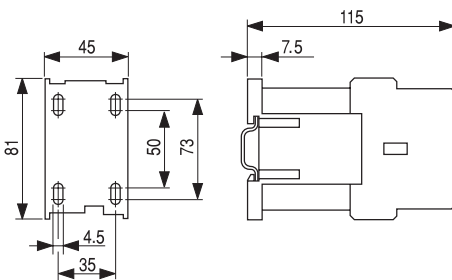

Ring terminal

Frontal mounting

BCRF\_\_\_ 0.015kg

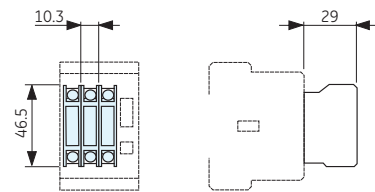

DC

RL4RD\_\_\_R◆ 0.490kg

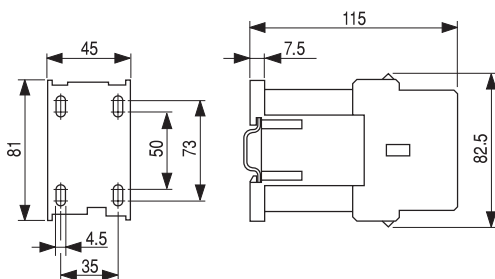

Dimensions in mm (inch = mm x 0.03937) - Weight in kg (lb = kg x 2.2046)



**Timed auxiliary contact blocks**

**Screw terminal**  
**Front mounting**  
**BTLF\_** 0.085kg

**Ring terminal**  
**Front mounting**  
**BTRF\_** 0.085kg

**Mechanical (-/electrical) interlock**

**BELA** 0.025kg  
**BELA02** 0.025kg

**Mechanical latch block**

**RMLF\_** 0.082kg

**Voltage suppressor blocks**

**BSLR2\_** 0.020kg  
**BSLDZ\_** 0.020kg  
**BSLV3\_** 0.020kg

**Electronic timer block**

**BETL\_ C** 0.040kg  
**BETL\_ D** 0.040kg

**Interface**

**IMR\_** 0.060kg  
**IMRF\_** 0.050kg  
**IMSSD** 0.045kg  
**IMAMS** 0.045kg

# Auxiliary Contactors Alphabetical Index

Cat. no.	Ref. no.	Cat. pg	Cat. no.	Ref. no.	Cat. pg
MCRA004AT6	102102	B.3	RL4RA040TJ	104003	B.7
MCRA004AT7	102103	B.3	RL4RA040TN	104004	B.7
MCRA004ATJ	100043	B.3	RL4RA040TU	104005	B.7
MCRA004ATN	100044	B.3	RL4RA031TJ	104013	B.7
MCRA004ATW	102095	B.3	RL4RA031TN	104014	B.7
MCRA013AT1	102076	B.3	RL4RA031TU	104015	B.7
MCRA013AT6	102081	B.3	RL4RA022TJ	104023	B.7
MCRA013AT7	102082	B.3	RL4RA022TN	104024	B.7
MCRA013ATJ	100033	B.3	RL4RA022TU	104025	B.7
MCRA013ATM	102070	B.3	RL4RA004TJ	104033	B.7
MCRA013ATN	100034	B.3	RL4RA004TN	104034	B.7
MCRA013ATU	100035	B.3	RL4RA004TU	104035	B.7
MCRA013ATW	101969	B.3	RL4RA022GK	104908	B.7
MCRA013ATY	101985	B.3	RL4RA022GN	104912	B.7
MCRA022AT1	102055	B.3	RL4RA022G1	104921	B.7
MCRA022AT2	102056	B.3	RL4RD004TWJ	104974	B.7
MCRA022AT6	102060	B.3	RL4RA040TK	109005	B.7
MCRA022AT7	102061	B.3	RL4RA040T1	109016	B.7
MCRA022AT9	108236	B.3	RL4RA040T6	109021	B.7
MCRA022ATJ	100023	B.3	RL4RA040T7	109022	B.7
MCRA022ATK	102048	B.3	RL4RA031TK	109029	B.7
MCRA022ATM	102049	B.3	RL4RA031TL	109030	B.7
MCRA022ATN	100024	B.3	RL4RA031TY	109038	B.7
MCRA022ATU	100025	B.3	RL4RA031T1	109040	B.7
MCRA022ATW	102053	B.3	RL4RA031T6	109045	B.7
MCRA022ATY	102054	B.3	RL4RA031T7	109046	B.7
MCRA031AT1	102034	B.3	RL4RA022TK	109053	B.7
MCRA031AT2	102035	B.3	RL4RA022TL	109054	B.7
MCRA031AT6	102039	B.3	RL4RA022TY	109062	B.7
MCRA031AT9	108238	B.3	RL4RA022T1	109064	B.7
MCRA031ATJ	100013	B.3	RL4RA022T2	109065	B.7
MCRA031ATK	102027	B.3	RL4RA022T6	109069	B.7
MCRA031ATM	102028	B.3	RL4RA022T7	109070	B.7
MCRA031ATN	100014	B.3	RL4RA004T1	109088	B.7
MCRA031ATU	100015	B.3	RL4RA004T6	109093	B.7
MCRA031ATW	102032	B.3	RL4RA004T7	109094	B.7
MCRA040AT1	102013	B.3	RL4RD040TWJ	109421	B.7
MCRA040AT6	102018	B.3	RL4RD040TB	113000	B.7
MCRA040AT7	102019	B.3	RL4RD022TWJ	113002	B.7
MCRA040AT9	108237	B.3	RL4RD022TW1	113004	B.7
MCRA040ATJ	100003	B.3	RL4RD040TD	113006	B.7
MCRA040ATK	102006	B.3	RL4RD040TG	113007	B.7
MCRA040ATM	102007	B.3	RL4RD040TJ	113008	B.7
MCRA040ATN	100004	B.3	RL4RD040TN	113009	B.7
MCRA040ATU	100005	B.3	RL4RD040TWD	113012	B.7
MCRA040ATW	102011	B.3	RL4RD022TWD	113014	B.7
MCR004ATWG	101990	B.3	RL4RD031TWJ	113015	B.7
MCR004ATWJ	220398	B.3	RL4RD031TD	113016	B.7
MCR004ATWL	220399	B.3	RL4RD031TG	113017	B.7
MCR004ATWN	220400	B.3	RL4RD031TJ	113018	B.7
MCR013ATWN	220448	B.3	RL4RD031TN	113019	B.7
MCR022ATB	100020	B.3	RL4RD022TB	113020	B.7
MCR022ATD	100026	B.3	RL4RD022TD	113026	B.7
MCR022ATG	100027	B.3	RL4RD022TG	113027	B.7
MCR022ATJ	100028	B.3	RL4RD022TJ	113028	B.7
MCR022ATWD	220408	B.3	RL4RD022TN	113029	B.7
MCR022ATWD	102485	B.3	RL4RD004TD	113036	B.7
MCR022ATWG	100082	B.3	RL4RD004TG	113037	B.7
MCR022ATWJ	220405	B.3	RL4RD004TJ	113038	B.7
MCR022ATWL	220456	B.3	RL4RD004TN	113039	B.7
MCR022ATWN	220402	B.3	RL4RD040TK	113054	B.7
MCR031ATB	100010	B.3	RL4RD040TT	113057	B.7
MCR031ATD	100016	B.3	RL4RD031TH	113061	B.7
MCR031ATG	100017	B.3	RL4RD031TK	113063	B.7
MCR031ATJ	100018	B.3	RL4RD022TH	113070	B.7
MCR031ATWD	220409	B.3	RL4RD022TK	113072	B.7
MCR031ATWD	102348	B.3	RL4RD022TT	113075	B.7
MCR031ATWG	100070	B.3	RL4RD004TK	113081	B.7
MCR031ATWJ	220406	B.3	RL4RD004TT	113084	B.7
MCR031ATWL	220457	B.3	RL4RA031T9	113964	B.7
MCR031ATWN	220403	B.3	RL4RD031TWN	247007	B.7
MCR040ATB	100000	B.3	RL4RD022TWN	247939	B.7
MCR040ATD	100006	B.3			
MCR040ATG	100007	B.3			
MCR040ATJ	100008	B.3			
MCR040ATWD	220410	B.3			
MCR040ATWG	220463	B.3			
MCR040ATWJ	220407	B.3			
MCR040ATWL	220458	B.3			
MCR040ATWN	220404	B.3			
MCR040ATWN	102572	B.3			
MCR022ATWL	220456	B.3			
MCR031ATWL	220457	B.3			
MCR040ATWL	220458	B.3			
MCR040ATWG	220463	B.3			
MCRA013ATW	101969	B.3			
MCRA013ATY	101985	B.3			
MCR004ATWG	101990	B.3			

