



#### Main applications

- Thermostat
- Humidity switch
- Mould cooling units
- Industrial refrigerators
- Air conditioning
- Food processing equipment

#### Main features

- Faceplate configurable input
- Protected by a personal code
- Configurable by a serial link
- Transmitter power supply incorporated
- Custom thermocouple linearisation available
- Internal linearisation for engineering units
- Labels provided for the more common physical units
- Sampling time and trip intervention programmable between 15 and 120msec with resolution between 2000 and 8000 steps
- Retransmission of the measured variable signal
- 3 trip points, completely configurable from the faceplate

#### GENERAL

Microprocessor based indicator in 72x36 format manufactured with SMT.

The instruments have a lexan membrane faceplate (guaranteed to IP65) which has 3 keys, a 2, 3 / 4 digit display.

The input signal can be selected from a wide range of sensors:

- Thermocouples of type J, K, R, S, T, B, E, N, L GOST, U, G, D, C
- Resistance thermometers Pt100, Pt100J (japanese standard) 2 / 3 wire
- PTC and NTC themistors
- Linear inputs 0 to 60/12 to 60mV, 0 to 20/4 to 20mA, 0 to 10/2 to 10/0 to 5/1 to 5/0 to 1/0, 2 to 1V

The selection is made using the faceplate keys and correct input contact.

No external shunt or adapter is required.

A digital input (24Vdc/4mA) is available for resetting, hold, flash, peak handling or releasing latch. The instruments have a maximum of 3 outputs that can be mechanical relays (5A/250V) or logic outputs (0 to 11Vdc). In alternative to output 3 a 4 to 20mA output is available (max. 150Ω) for retransmission of the measured input signal, or a digital input (24Vdc/4mA) can be provided which can be used for resetting, hold, flash, peak handling or releasing latch.

Finally, a triac can be fitted (as an alternative to the other two relay outputs) that can drive resistive loads up to a maximum of 2,5A at 220V.

The programming of the instrument is made easy by grouping the parameters in function blocks (**CFG** for the alarm hysteresis, **Inp** for the inputs, **Out** for the outputs...) and by a simplified data entry menu.

The configuration can be simplified even further using the PC programming kit made up of a connection cable and a menu guide program that runs under Windows (see data sheet cod. WINSTRUM).

A configurable personal software protection code (password protection) can be used to restrict the levels of editing and displaying the configuration parameters.

#### TECHNICAL DATA

##### INPUTS

Accuracy 0,2% f.s. ±1digit.  
Sampling time 120msec for temperature sensors, configurable for linear inputs down to a minimum of 15msec with reduction of the resolution to 2000 steps. Configurable decimal point position for linear inputs, for TC, RTD, PTC and NTC inputs, only one decimal digit is allowed in the maximum display range of -199.9 to 999.9 (4 digit display), -99.9 to 99.9 (3 digit display with sign), -9.9 to 9.9 (2 digit display with sign) with indication of open circuit thermocouple or RTD, PTC or NTC in open or short circuit, indication of over- and under-range for linear inputs.

##### TC - Thermocouple

Automatic cold junction compensation (4 digit)

<b>J</b>	0 to 1000°C / 32 to 1832°F
<b>K</b>	0 to 1300°C / 32 to 2372°F
<b>R</b>	0 to 1750°C / 32 to 3182°F
<b>S</b>	0 to 1750°C / 32 to 3182°F
<b>T</b>	-200 to 400°C / -328 to 752°F
<b>B</b>	44 to 1800°C / 111 to 3272°F
<b>E</b>	-100 to 750°C / -148 to 1382°F
<b>N</b>	0 to 1300°C / 32 to 2372°F
<b>L-GOST</b>	0 to 600°C / 32 to 1112°F
<b>U</b>	-200 to 400°C / -328 to 752°F

**G** 0 to 2300°C / 32 to 4172°F  
**D** 0 to 2300°C / 32 to 4172°F  
**C** 0 to 2300°C / 32 to 4172°F  
**custom** -1999 to 9999

**TC - Thermocouple**

**(3 digit + sign)**

**J** 0 to 999°C / 32 to 999°F  
**K** 0 to 999°C / 32 to 999°F  
**R** 0 to 999°C / 32 to 999°F  
**S** 0 to 999°C / 32 to 999°F  
**T** -200 to 400°C / -328 to 752°F  
**B** not available  
**E** -100 to 750°C / -148 to 999°F  
**N** 0 to 999°C / 32 to 999°F  
**L-GOST** 0 to 600°C / 32 to 999°F  
**U** -200 to 400°C / -328 to 752°F  
**G** 0 to 999°C / 32 to 999°F  
**D** 0 to 999°C / 32 to 999°F  
**C** 0 to 999°C / 32 to 999°F  
**custom** -999 to 999

**(2 digit + sign)**

**J** 0 to 99°C / 32 to 99°F  
**K** 0 to 99°C / 32 to 99°F  
**R** 0 to 99°C / 32 to 99°F  
**S** 0 to 99°C / 32 to 99°F  
**T** -99 to 99°C / -99 to 99°F  
**B** not available  
**E** not available  
**N** not available  
**L-GOST** 0 to 99°C / 32 to 99°F  
**U** -99 to 99°C / -99 to 99°F  
**G** not available  
**D** not available  
**C** not available  
**custom** -99 to 99

**RTD (2 or 3 wire)**

**(4 digit)**

PT100 -200 to 600°C / -328 to 1112°F  
 JPT100 -200 to 600°C / -328 to 1112°F

**(3 digit + sign)**

PT100 -200 to 600°C / -328 to 999°F  
 JPT100 -200 to 600°C / -328 to 999°F

**(2 digit + sign)**

PT100 -99 to 99°C / -99 to 99°F  
 JPT100 -99 to 99°C / -99 to 99°F

**PTC**

990Ω, 25°C  
**(4 digit and 3 digit + sign)**  
 -55 to 120°C / -67 to 248°F

**(2 digit + sign)**

-55 to 99°C / -67 to 99°F

**NTC**

1KΩ, 25°C  
**(4 digit and 3 digit + sign)**  
 -10 to 70°C / 14 to 158°F

**(2 digit + sign)**

-10 to 70°C / 14 to 99°F

**DC - Linear**

With scale configurable within the limits:

-1999 to 9999 (4 digit),  
 -999 to 999 (3 digit + sign)  
 -99 to 99 (2 digit + sign)  
 0 to 60mV / 12 to 60mV  
 0 to 10V / 2 to 10V  
 0 to 5V / 1 to 5V  
 0 to 1V / 0,2 to 1V  
 0 to 20mA / 4 to 20mA  
 Input impedance for voltage signals  
 Ri > 500KΩ, for current signals Ri = 50Ω.  
 32-segment configurable linearisation can be used.

**Potentiometer**

Supply 1V >100Ω

**Digital input**

Ri = 5,6KΩ (24V, 4mA) isolated to 1500V  
 Function is configurable as alarm or memory reset, hold, flash zero, display of the peak value (max., min. or peak to peak).

**OUTPUTS**

**Relay**

with NO (NC) contacts rated at 5A, 250V at cosφ = 1.

**Logic** (only for Out1 and Out2)

Output, type D 11Vdc, Rout = 220Ω (6V/20mA).

**Triac** (for Out1, disabled Out2)

24 to 240Vac ±10%, 2A max  
 Snubberless, I<sup>2</sup>t = 128A<sup>2</sup>sec

A maximum of three trip points can be set as absolute, deviation or symmetrical deviation alarms.

The hysteresis of each alarm is configurable individually.

Alarm masking with exclusion on power up, with memory, delay and minimum intervention time.

The trip point may be set at any point on the scale.

**Analogue retransmission**

4 to 20mA on max. 60Ω

**POWER SUPPLY**

11...27Vdc, 18...27Vac ± 10%  
 50/60Hz, max. 4,5VA

**TRANSMITTER POWER SUPPLY**

2 wire, 18Vdc ±10%, max. 50mA  
 1,2Vdc for potentiometer >100Ω  
 (non isolated from sensor input)

**AMBIENT CONDITIONS**

**Working temperature range:** 0 to 50°C  
**Storage temperature range:** -20 to 70°C  
**Humidity:** 20 to 85%Ur non-condensing

**WEIGHT**

110g. in the complete version

**FACEPLATE DESCRIPTION**

- A - PV display: indication of process variable
- B - Label for engineering units
- C - "Function" key
- D - "Raise" and "Lower" keys
- E - Indication of the states of the outputs

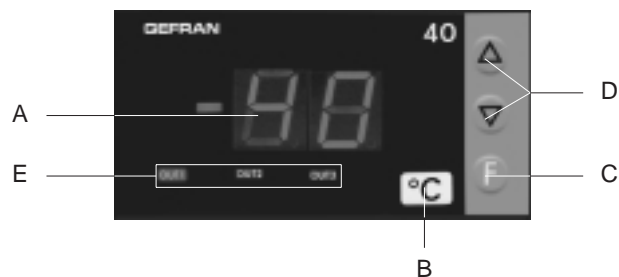

Red LED display  
 IP65 faceplate protection

## DIMENSIONS and CUT-OUT

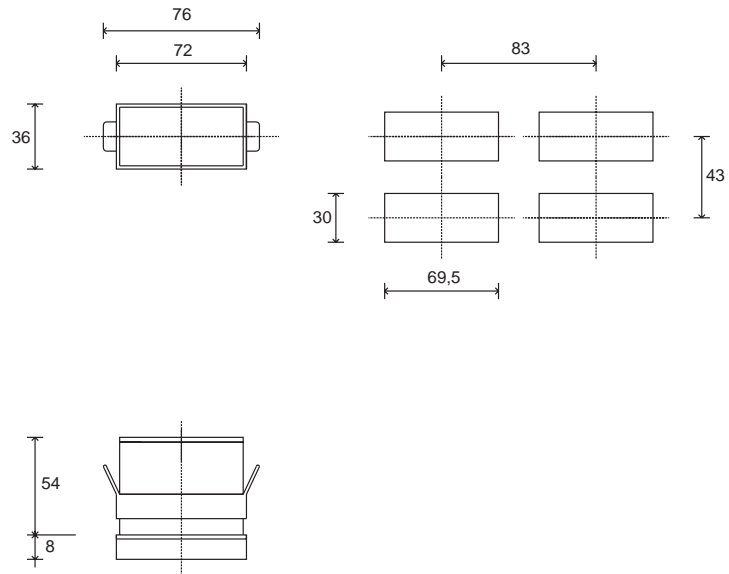

Dimensions: 72x36mm depth 54mm

## CONNECTION DIAGRAM

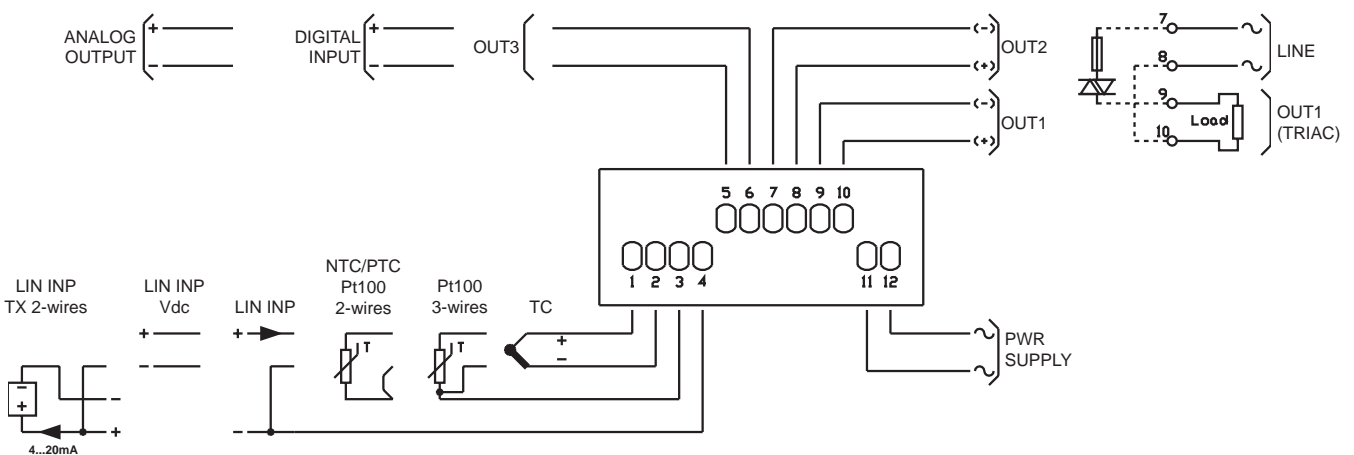

For a correct installation see the warnings in the users' manual

**ORDER CODE**

40T 72       9

NR. DIGITS	
2 + sign	2
3 + sign	3
4	4

TRANSMITTER POWER SUPPLY	
None	0 0
For T input (alternative to RTD, PTC, NTC)	
1,2Vdc for potentiometer *	0 1
18Vdc, 50mA for 2-wire transmitter	2 4

\* R77 version for potentiometer input (Rinput >10Mohm)

POWER SUPPLY	
9	11...27Vdc, 18...27Vac not isolated

DIGITAL INPUT / RETRANSMISSION OUTPUT / OUTPUT 3	
0 0	None
0 1	Digital input
0 2	Analogue output 4 to 20mA on max 60Ω
R 0	Relay

OUTPUT 1, OUTPUT 2	
R R	Relay, Relay
R D	Relay, Logic
T 0	Triac, None

GEFRAN spa reserves the right to make any modification of the design or function, at any moment without prior notice

	The instrument conforms to the European Directives 2004/108/CE and 2006/95/CE with reference to the generic standards: <b>EN 61000-6-2</b> (immunity in industrial environment) <b>EN 61000-6-3</b> (emission in residential environment) <b>EN 61010-1</b> (safety)
--	---