

**769 L
MALE ELBOW**

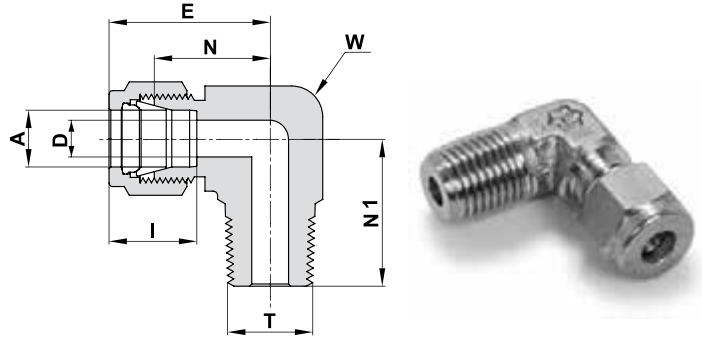

TUBE (METRIC) MALE NPT THREAD

Ordering Information	A	T	D	W		N	E	N1	I
	Tube O.D.	(NPT)		Wrench Flat					
	mm	inch	mm	inch	mm	mm	mm	mm	mm
769L_ 3 X 1/8	3	1/8	2.4	7/16	11.1	17.0	23.6	17.8	12.9
769L_ 3 X 1/4	3	1/4	2.4	1/2	12.7	18.0	24.6	23.4	12.9
769L_ 4 X 1/8	4	1/8	2.4	1/2	12.7	18.8	25.4	18.8	13.7
769L_ 4 X 1/4	4	1/4	2.4	1/2	12.7	18.8	25.4	23.4	13.7
769L_ 6 X 1/8	6	1/8	4.8	1/2	12.7	19.6	27.0	18.8	15.3
769L_ 6 X 1/4	6	1/4	4.8	1/2	12.7	19.6	27.0	23.4	15.3
769L_ 6 X 3/8	6	3/8	4.8	11/16	17.5	22.4	29.8	26.2	15.3
769L_ 6 X 1/2	6	1/2	4.8	13/16	20.6	24.4	31.8	33.0	15.3
769L_ 8 X 1/8	8	1/8	4.8	9/16	14.3	21.3	28.8	19.8	16.2
769L_ 8 X 1/4	8	1/4	6.4	9/16	14.3	21.3	28.8	24.4	16.2
769L_ 8 X 3/8	8	3/8	6.4	11/16	17.5	23.1	30.6	26.2	16.2
769L_ 8 X 1/2	8	1/2	6.4	13/16	20.6	25.1	32.6	33.0	16.2
769L_ 10 X 1/8	10	1/8	4.8	11/16	17.5	23.9	31.5	21.6	17.2
769L_ 10 X 1/4	10	1/4	7.1	11/16	17.5	23.9	31.5	26.2	17.2
769L_ 10 X 3/8	10	3/8	7.9	11/16	17.5	23.9	31.5	26.2	17.2
769L_ 10 X 1/2	10	1/2	7.9	13/16	20.6	25.9	33.5	33.0	17.2
769L_ 12 X 1/8	12	1/8	4.8	13/16	20.6	25.9	36.0	23.6	22.8
769L_ 12 X 1/4	12	1/4	7.1	13/16	20.6	25.9	36.0	28.2	22.8
769L_ 12 X 3/8	12	3/8	9.5	13/16	20.6	25.9	36.0	28.2	22.8
769L_ 12 X 1/2	12	1/2	9.5	13/16	20.6	25.9	36.0	33.0	22.8
769L_ 12 X 3/4	12	3/4	9.5	1 1/16	27.0	29.7	39.8	36.8	22.8
769L_ 15 X 1/2	15	1/2	11.9	15/16	23.8	27.9	38.0	35.1	24.4
769L_ 16 X 3/8	16	3/8	9.5	15/16	23.8	27.9	38.0	30.2	24.4
769L_ 16 X 1/2	16	1/2	11.9	15/16	23.8	27.9	38.0	35.1	24.4
769L_ 16 X 3/4	16	3/4	12.7	1 1/16	27.0	29.7	39.8	36.8	24.4
769L_ 18 X 1/2	18	1/2	11.9	1 1/16	27.0	29.7	39.8	36.8	24.4
769L_ 18 X 3/4	18	3/4	15.1	1 1/16	27.0	29.7	39.8	36.8	24.4
769L_ 20 X 1/2	20	1/2	11.9	1 3/8	34.9	34.5	44.6	41.7	26.0
769L_ 20 X 3/4	20	3/4	15.9	1 3/8	34.9	34.5	44.6	41.7	26.0
769L_ 22 X 3/4	22	3/4	15.9	1 3/8	34.9	34.5	44.6	41.7	26.0
769L_ 22 X 1	22	1	18.3	1 3/8	34.9	34.5	44.6	46.5	26.0
769L_ 25 X 3/4	25	3/4	15.9	1 3/8	34.9	36.8	49.1	41.7	31.3
769L_ 25 X 1	25	1	21.8	1 3/8	34.9	36.8	49.1	46.5	31.3
769L_ 38 X 1 1/2	*38	1 1/2	33.7	-	55.0	56.4	84.0	60.4	49.4

* Including low friction paste, see page 91

"D" - Dimension is minimum opening. Dimensions are for reference only, and are subject to change without notice.

769 L MALE ELBOW

(Cont'd)

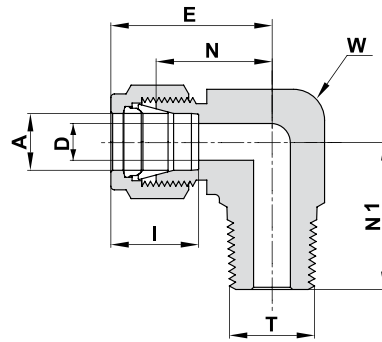

TUBE (INCH) MALE NPT THREAD

Ordering Information	A Tube O.D.		T (NPT)	D		W Wrench Flat		N		E		N1		I	
	inch	mm	inch	inch	mm	inch	mm	inch	mm	inch	mm	inch	mm	inch	mm
769L _ 1/16 X 1/16	1/16	1.58	1/16	.05	1.27	7/16	11.1	.60	15.24	.75	19.05	.70	17.78	.34	8.6
769L _ 1/16 X 1/8	1/16	1.58	1/8	.05	1.27	7/16	11.1	.60	15.24	.75	19.05	.70	17.78	.34	8.6
769L _ 1/8 X 1/16	1/8	3.17	1/16	.09	2.28	7/16	11.1	.67	17.02	.93	23.62	.70	17.78	.50	12.7
769L _ 1/8 X 1/8	1/8	3.17	1/8	.09	2.28	7/16	11.1	.67	17.02	.93	23.62	.70	17.78	.50	12.7
769L _ 1/8 X 1/4	1/8	3.17	1/4	.09	2.28	1/2	12.7	.71	18.03	.97	24.64	.92	23.37	.50	12.7
769L _ 3/16 X 1/8	3/16	4.76	1/8	.12	3.04	1/2	12.7	.74	18.80	1.00	25.40	.74	18.80	.54	13.7
769L _ 3/16 X 1/4	3/16	4.76	1/4	.12	3.04	1/2	12.7	.74	18.80	1.00	25.40	.92	23.37	.54	13.7
769L _ 1/4 X 1/16	1/4	6.35	1/16	.12	3.04	1/2	12.7	.77	19.56	1.06	26.92	.74	18.80	.60	15.2
769L _ 1/4 X 1/8	1/4	6.35	1/8	.19	4.82	1/2	12.7	.77	19.56	1.06	26.92	.74	18.80	.60	15.2
769L _ 1/4 X 1/4	1/4	6.35	1/4	.19	4.82	1/2	12.7	.77	19.56	1.06	26.92	.92	23.37	.60	15.2
769L _ 1/4 X 3/8	1/4	6.35	3/8	.19	4.82	11/16	17.5	.88	22.35	1.17	29.71	1.03	26.16	.60	15.2
769L _ 1/4 X 1/2	1/4	6.35	1/2	.19	4.82	13/16	20.6	.96	24.38	1.25	31.75	1.30	33.02	.60	15.2
769L _ 5/16 X 1/8	5/16	7.93	1/8	.19	4.82	9/16	14.3	.84	21.34	1.13	28.70	.78	19.81	.64	16.2
769L _ 5/16 X 1/4	5/16	7.93	1/4	.25	6.35	9/16	14.3	.84	21.34	1.13	28.70	.96	24.38	.64	16.2
769L _ 5/16 X 3/8	5/16	7.93	3/8	.25	6.35	11/16	17.5	.91	23.11	1.20	30.48	1.03	26.16	.64	16.2
769L _ 3/8 X 1/8	3/8	9.52	1/8	.19	4.82	5/8	15.9	.91	23.11	1.20	30.48	.82	20.83	.66	16.8
769L _ 3/8 X 1/4	3/8	9.52	1/4	.28	7.11	5/8	15.9	.91	23.11	1.20	30.48	1.00	25.40	.66	16.8
769L _ 3/8 X 3/8	3/8	9.52	3/8	.28	7.11	11/16	17.5	.94	23.87	1.23	31.24	1.03	26.16	.66	16.8
769L _ 3/8 X 1/2	3/8	9.52	1/2	.28	7.11	13/16	20.6	1.02	25.90	1.31	33.28	1.30	33.02	.66	16.8
769L _ 3/8 X 3/4	3/8	9.52	3/4	.28	7.11	1 1/16	27.0	1.17	29.71	1.46	37.08	1.45	36.83	.66	16.8
769L _ 1/2 X 1/4	1/2	12.70	1/4	.28	7.11	13/16	20.6	1.02	25.90	1.42	36.07	1.11	28.19	.90	22.9
769L _ 1/2 X 3/8	1/2	12.70	3/8	.38	9.50	13/16	20.6	1.02	25.90	1.42	36.07	1.11	28.19	.90	22.9
769L _ 1/2 X 1/2	1/2	12.70	1/2	.41	10.41	13/16	20.6	1.02	25.90	1.42	36.07	1.30	33.02	.90	22.9
769L _ 1/2 X 3/4	1/2	12.70	3/4	.41	10.41	1 1/16	27.0	1.17	29.71	1.57	39.88	1.45	36.83	.90	22.9
769L _ 5/8 X 3/8	5/8	15.87	3/8	.38	9.61	15/16	23.8	1.10	27.94	1.50	38.10	1.19	30.23	.96	24.4
769L _ 5/8 X 1/2	5/8	15.87	1/2	.47	11.94	15/16	23.8	1.10	27.94	1.50	38.10	1.38	35.05	.96	24.4
769L _ 5/8 X 3/4	5/8	15.87	3/4	.50	12.70	1 1/16	27.0	1.17	29.71	1.57	39.88	1.45	36.83	.96	24.4
769L _ 3/4 X 1/2	3/4	19.05	1/2	.47	11.94	1 1/16	27.0	1.17	29.71	1.57	39.88	1.45	36.83	.96	24.4
769L _ 3/4 X 3/4	3/4	19.05	3/4	.62	15.74	1 1/16	27.0	1.17	29.71	1.57	39.88	1.45	36.83	.96	24.4
769L _ 7/8 X 3/4	7/8	22.22	3/4	.62	15.74	1 3/8	34.9	1.36	34.54	1.76	44.70	1.64	41.66	1.02	25.9
769L _ 1 X 3/4	1	25.40	3/4	.62	15.74	1 3/8	34.9	1.45	36.83	1.93	49.02	1.64	41.66	1.23	31.2
769L _ 1 X 1	1	25.40	1	.86	21.84	1 3/8	34.9	1.45	36.83	1.93	49.02	1.83	46.48	1.23	31.2
769L _ 1 1/4 X 1 1/4	*1 1/4	31.75	1 1/4	1.09	27.70	1 11/16	42.9	1.75	44.45	2.62	66.50	1.88	47.75	1.62	41.2
769L _ 1 1/2 X 1 1/2	*1 1/2	38.10	1 1/2	1.34	34.00	2	50.8	2.00	50.80	3.07	78.00	2.38	60.45	1.97	50.0
769L _ 2 X 2	*2	50.80	2	1.81	45.97	2 3/4	69.9	2.75	69.85	4.22	107.19	2.78	70.61	2.66	67.6

* Including low friction paste, see page 91

"D" - Dimension is minimum opening. Dimensions are for reference only, and are subject to change without notice.