

Pushbutton Enclosures - NEMA 12, 13

1490/ 1490M Sloped Front Console Series

Operator Interface Enclosure

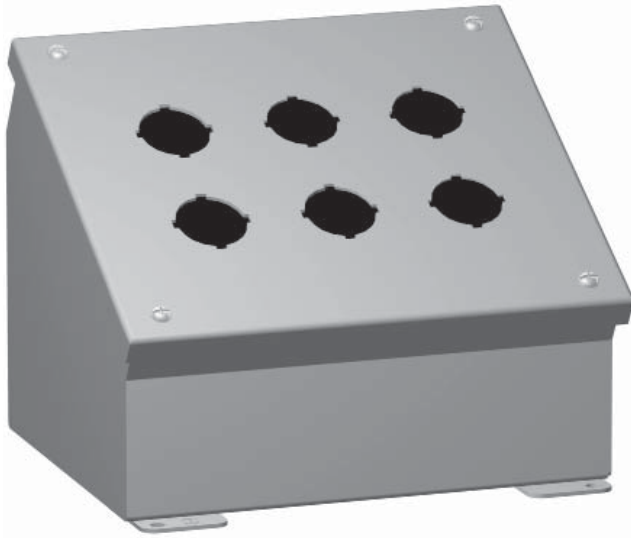

Application

- Designed to accept standard heavy duty oil tight pushbuttons, switches and pilot lights.
- Ideal for wall or surface mounting to provide the necessary control slope.
- Provides protection from dirt, dust, oil and water.

Standards

- UL 508 Type 12 and 13
- CSA Type 12 and 13
- JIC standard EGP-1-1967
- **Complies with**
 - NEMA Type 12 and 13
 - IEC 60529, IP54
- Appropriate components are required to maintain these standards.

Construction

- Formed 14 gauge steel.
- Smooth continuously welded seams.
- Construction provides either a 30° or 60° slope on front cover depending on mounting position.
- Welded brackets provide for enclosure mounting.
- Captive cover screws thread into sealed wells.
- Larger enclosures provide internally hinged removable covers designed to hold the cover open during wiring (as noted in table).
- Oil resistant gasket and adhesive.
- A bonding stud is provided on the door and a grounding stud is provided in the enclosure.

Finish

- Cover and enclosure are phosphatized and finished in ANSI 61 gray powder coating.

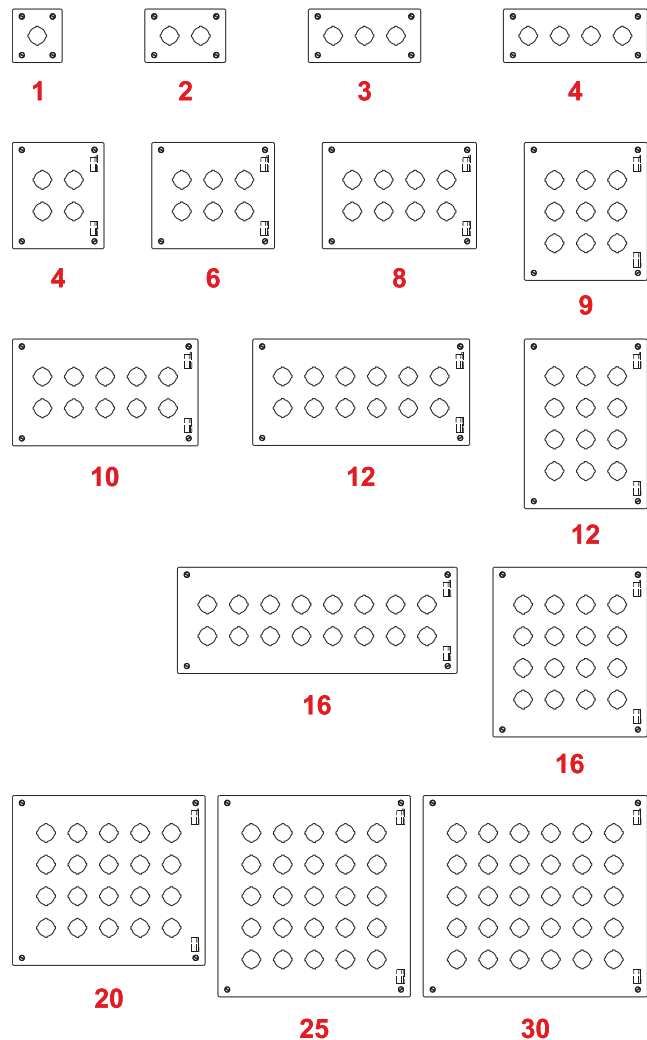

Accessories

- Hole plugs...see page 435
- Pedestals...see page 454

Technical references and CAD downloads available at www.hammondmfg.com

All dimensions in inches unless specified otherwise

Pushbutton Enclosures

Pushbutton Enclosures - NEMA 12, 13

1490/ 1490M Sloped Front Console Series

Operator Interface Enclosure

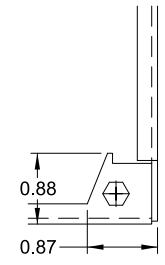
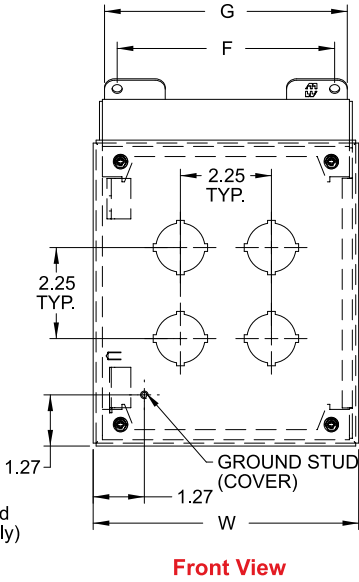
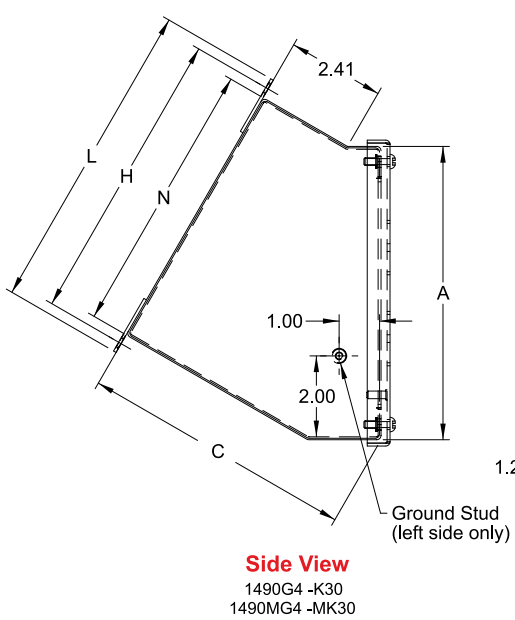

Hinge Detail
Retractable pin allows door to be mount on left side or right side.

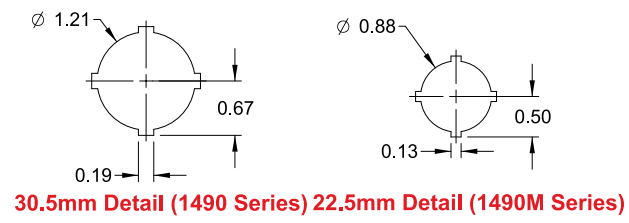
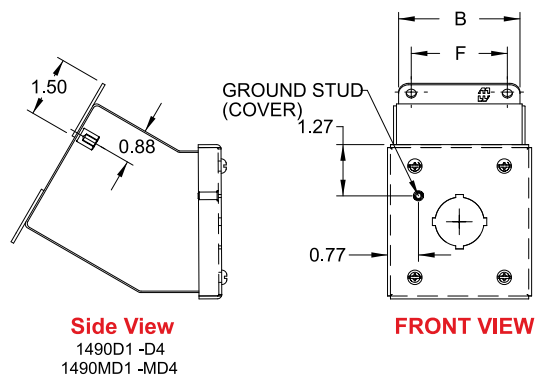

Pushbutton Enclosures

Part No.	No. Of Holes	A	B	C	F	G	H	L	N	W	Z	Ship Wt. lbs.
1490D1 ¹	1	3.50	3.25	4.88	2.38	3.00	4.03	4.53	3.53	3.56	3.81	2
1490D2 ¹	2	3.50	5.50	4.88	4.63	5.25	1.03	4.53	3.53	5.81	3.81	3
1490D3 ¹	3	3.50	7.75	4.88	6.88	7.50	4.03	4.53	3.53	8.06	3.81	5
1490D4 ¹	4	3.50	10.00	4.88	9.13	8.75	4.03	4.53	3.53	10.31	3.81	6
1490G4	4	7.25	6.25	6.75	5.38	6.00	7.28	7.78	6.78	6.56	7.56	6
1490G6	6	7.25	8.50	6.75	7.63	8.25	7.28	7.78	6.78	8.81	7.56	7
1490G8	8	7.25	10.75	6.75	9.88	10.50	7.28	7.78	6.78	11.06	7.56	9
1490H9	9	9.50	8.50	7.88	7.63	8.25	9.25	9.75	8.75	8.81	9.81	9
1490G10	10	7.25	13.00	6.75	12.13	12.75	7.28	7.78	6.78	13.31	7.56	10
1490G12	12	7.25	15.25	6.75	14.38	15.00	7.28	7.78	6.78	15.56	7.56	11
1490J12	12	11.75	8.50	9.00	7.63	8.25	11.19	11.69	10.69	8.81	12.06	13
1490G16	16	7.25	19.75	6.75	18.88	19.50	7.28	7.78	6.78	20.06	7.56	14
1490J16	16	11.75	10.75	9.00	9.88	10.50	11.19	11.69	10.69	11.06	12.06	14
1490J20	20	11.75	13.00	9.00	12.13	12.75	11.19	11.69	10.69	13.31	12.06	16
1490K25	25	14.00	13.00	10.13	12.13	12.75	13.13	13.63	12.63	13.31	14.31	17
1490K30	30	14.00	15.25	10.13	14.38	15.00	13.13	13.63	12.63	15.56	14.31	19

¹ Not hinged

Technical references and CAD downloads available at www.hammondmfg.com All dimensions in inches unless specified otherwise

Quality Products. Service Excellence.