

Pneumatic Damper Actuators

MP920 Pneumatic Damper Actuator



Provides proportional control of large dampers in HVAC systems or inlet vanes on a VAV fan. Positive positioner available

Dimensions in inches (millimeters)

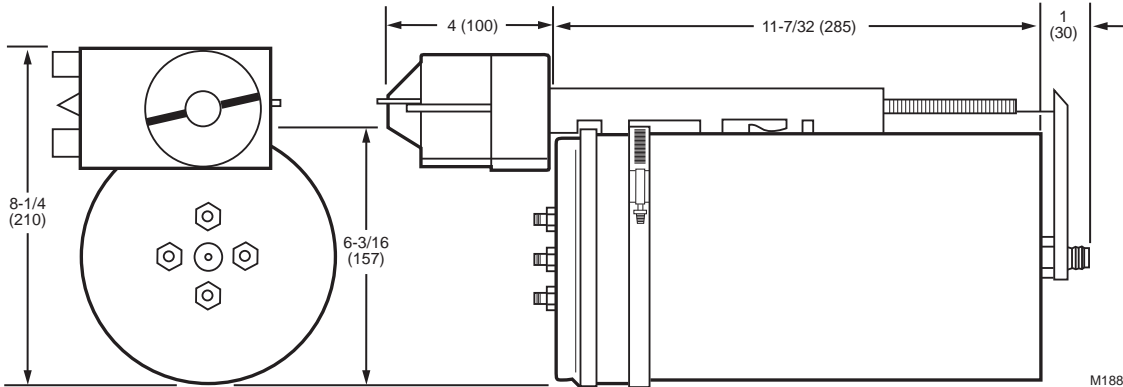

Actuator Type: Damper
Actuator Force: High
Fail Safe Mode: Spring Return
Diaphragm Effective Area: 24.8 sq in. (160 sq cm)
Temperature Range: -20 F to +158 F (-30 C to +70 C)
Maximum Operating Pressure: 29 psi (200 kPa)
Humidity Range: 5 to 95% RH

Accessories:

AK3557-Short Clevis Bag Assembly for 3/8-16 threaded rod
AK3558-Swivel Bracket Bag Assembly
AK3560-Balljoint, 3/8-24 threaded stud with couplings for 5/8-11 threaded rod and actuator shaft
AK3561-Balljoint, 3/8-24 threaded stud with couplings for 3/8-16 threaded rod
14004062-001-External Trunnion Mounting Bracket
14004241-002-Hitch Pin (Six Sets)
14004345-001-Positive Positioner Kit, 10 psi feedback spring

Product Number	Air Connections	Spring Range		Stroke		Includes
		(psi)	(kPa)	(inch)	(mm)	
MP920B1002/U	Barbed fitting for 1/4 in. O.D. plastic tubing	7.25 psi to 13 psi	50 kPa to 90 kPa	6 in.	150 mm	Actuator only. No Bracket. Order positive positioner, mounting and connecting hardware separately. See Installation Instructions form no. 95-6053