

M436A/M836A,B Damper Motors

INSTALLATION INSTRUCTIONS



APPLICATION

M436A/M836A,B Damper Motors are spring return (SR) motors used for residential and light commercial applications in Series 40 and Series 80 circuits.

A 2-wire, line voltage thermostat or other line voltage, spst controller must be used to control the M436A. A 24V spst controller or thermostat without heat anticipation is required to operate the M836A. The M836B requires 24V thermostat with a 0.75 A heat anticipator adjustment.

Each damper motor is supplied with a shaft coupling assembly and a crank arm assembly. With these accessories the motor shaft may be connected to the damper shaft directly or through a linkage.

FEATURES

- Motors provide two-position zone control.
- Used to operate outdoor air dampers for combustion or makeup air, changeover dampers for heating and cooling systems, minimum position dampers for ventilation and similar applications.
- Damper motors have an internal spdt switch for controlling auxiliary equipment, additional motors, or to provide a burner interlock switch.
- M436 Damper Motors require 120 or 240 Vac, 60 Hz power; M836 Damper Motors require 24 Vac, 60 Hz power.
- All models are supplied with a case and cover.
- Spring returns motor to start position in event of power interruption or failure.
- Hexagonal output shafts on both ends of motor with rotational direction stamped on motor case.
- M436A and M836A equipped with thermal breaker for overload protection during lifting stroke or when motor stalls.
- M836A Damper Motor with 128499 Bracket directly replaces M87A Damper Motor.
- These damper motors operate:
 - Outdoor air dampers for combustion air in boiler rooms.
 - Backdraft dampers for exhaust fans.
 - Outdoor air inlet dampers for industrial makeup air units.
 - Changeover dampers for heating and cooling systems.
 - Minimum position damper for ventilation from outdoor air.
 - Two-position zone control dampers.
 - Both motor types have an adjustable auxiliary switch (spdt) for operating auxiliary equipment or cascading motors, or to act as a burner interlock switch.



SPECIFICATIONS

IMPORTANT

The specifications given in this publication do not include normal manufacturing tolerances. Therefore, an individual unit may not exactly match the listed specifications. Also, this product is tested and calibrated under closely controlled conditions and some minor differences in performance can be expected if those conditions are changed.

TRADELINER® Models:

TRADELINER® models are selected and packaged to provide ease of stocking, ease of handling, and maximum replacement value. TRADELINE® model specifications are the same as those of the standard models except as noted below.

TRADELINER® Models Available:

M436A Damper Motor: 120 or 240 Vac, 60 Hz.
 M836A,B Damper Motors: 24 Vac, 60 Hz.

Accessories: See Table 1. Crank arm, mounting bracket #198545, and shaft coupling bag assemblies are included with motors; brackets listed in Table 1 must be ordered separately.

Table 1. Accessories Available

Type Bag Assembly	Bag Assembly Part Number	Bracket Included	Bracket Height
Bracket	16254AC	128499	2.25 in.
Bracket - Mounting	7640JM	126809	N/A
Bracket	7640JN	126336	0.5 in.
Crank Arm	7640JL	N/A	N/A
Shaft Coupling	7640JE	N/A	N/A
Bracket	198545	198545	2.25 in.

Additional Features:

TRADELINER® pack with cross reference label and instruction sheet.

Standard Models (See Table 2):

M436A Damper Motor: 120 or 240 Vac spring return motor for use with two-wire thermostats or other spst controllers. Includes internal adjustable spdt switch for controlling auxiliary equipment.
 M836A Damper Motor: 24 Vac spring return motor for use with spst controllers without heat anticipation. Includes internal adjustable spdt switch for controlling auxiliary equipment.
 M836B Damper Motor: 24 Vac spring return motor for use with spst controllers. If circuit has thermostat heat anticipation, set the anticipator at 0.75A. Includes internal adjustable spdt switch for controlling auxiliary equipment.

Table 2. M436/M836 standard models.

Model Number	Voltage (Vac)	Nominal Current (amperes)		Nominal Power (watts)		Maximum Load Torque (lb-in.)	Breakaway Torque ^a (lb-in.)	Opening Time ^b (sec)	Closing Time ^b (sec)	Damper Blade Area (sq ft)
		Opening	Holding	Opening	Holding					
M436A	120	0.37	0.12	27.0	8.5	20	30	30 (nominal)	25 (nominal)	13
	240	0.19	0.06	27.0	8.5					
M836A	24	1.85	0.6	27.0	8.5	20	30	30 (nominal)	25 (nominal)	13
M836B	24	1.34	0.73	20.3	11.2	15	30	25 (nominal)	25 (nominal)	10

^a Breakaway torque is available to overcome an occasionally frozen or seized damper or valve. The motor must not be used continuously at this rating.

^b 40 sec maximum.

Ambient Temperature Rating: 32° to 125°F (0° to 52°C).

Finish: Gray.

Dimensions: See Fig. 1.

Approvals:

Underwriters Laboratories Inc. Listed (M436A, M836A):
 File No. E4436, Guide No. XAPX.

Auxiliary Switch Ratings (In Amperes): See Table 3.

Pilot Duty: 40 VA at 120 or 240 Vac.

Table 3. Auxiliary switch ratings (in amperes).

Power	120 Vac	240 Vac
Full Load	7.2	3.6
Locked Rotor	43.2	21.6

Auxiliary Switch Action:

Spdt, normally open (R-B) contacts close during the power stroke and open during the return stroke. Can be adjusted to operate at any point between 5 and 70 degrees of motor stroke.

Angular Stroke: 75 degrees.

Weight: 4 lb, 10 oz (2.1 kg).

Optional Specifications:

M436 with crank arm.

M436A Damper Motor, 50 Hz for international applications.

Models for 220 or 240 Vac, with 50 second opening stroke, 25 second closing stroke. Includes ground and cover screws and 7640JL Bag Assembly.

M836A Damper Motor, 50 Hz for international applications.

Model is for 24 Vac, with 50 second opening stroke and 25 second closing stroke. Includes ground and cover screws and 7640JL Bag Assembly.

Accessories:

16254AC Bag Assembly, includes 128499 Mounting Bracket and screws (see Fig. 2 and 6).

7640JE Bag Assembly, includes drive bushings, adapter, and coupling for direct drive (see Fig. 4 and 7).

7640JL Bag Assembly, includes clamp and crank arm lever for crank arm drive (see Fig. 5 and 6).

7640JM Bag Assembly, includes 126809 Mounting Bracket and screws (see Fig. 3, 4 and 7).

7640JN Bag Assembly, includes 128336 Mounting Bracket and screws (see Fig. 2 and 6).

4074BRU Bag Assembly, includes extension adapter and screws for mounting Q607 Auxiliary Switch to M436A Damper Motor.

Q298B Linkage, includes damper crank arms, bushings, 1/4 in. (6.5 mm) and ball joint assemblies (see Fig. 6).

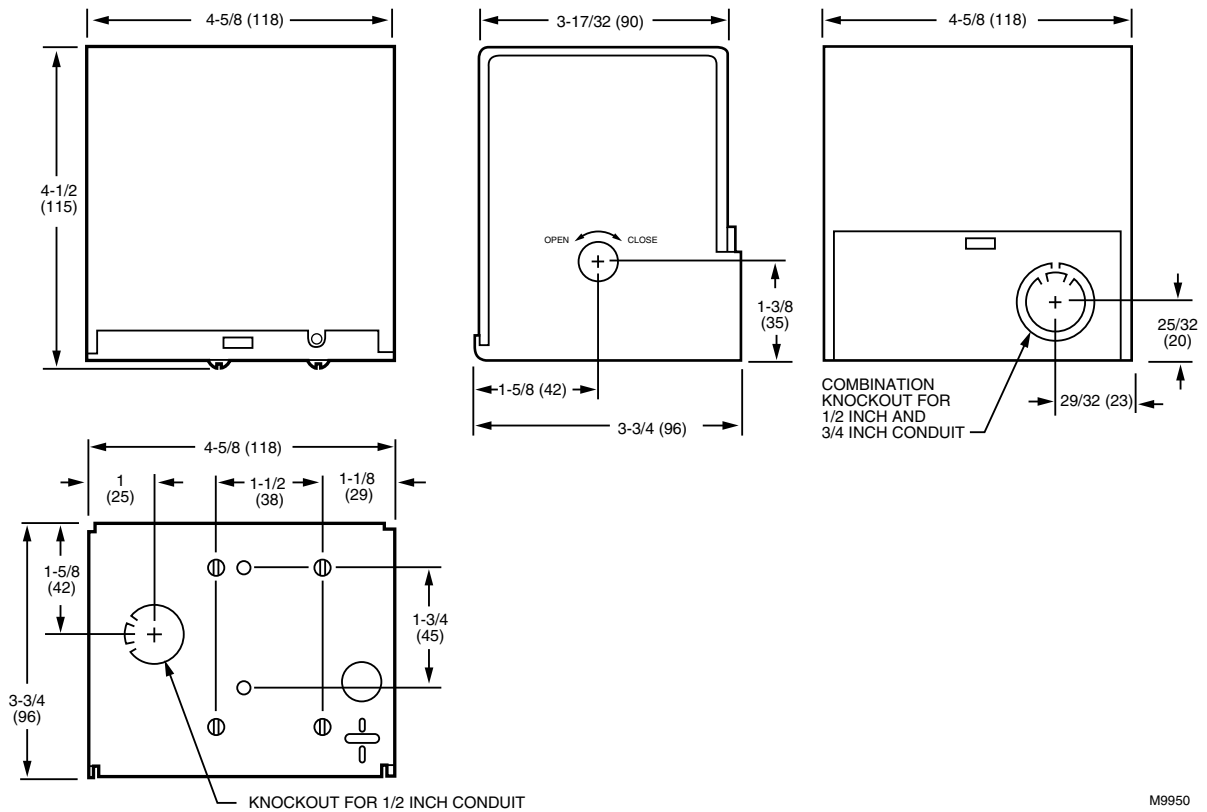

Fig. 1. M436 and M836 Damper Motors dimensions in in. (mm).

M9950

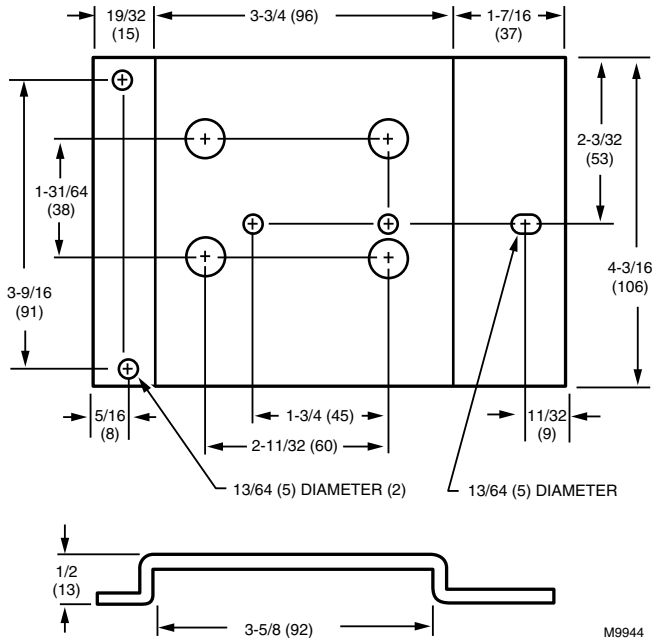

Fig. 2. 128336, 128499 Mounting Brackets dimensions in in. (mm).

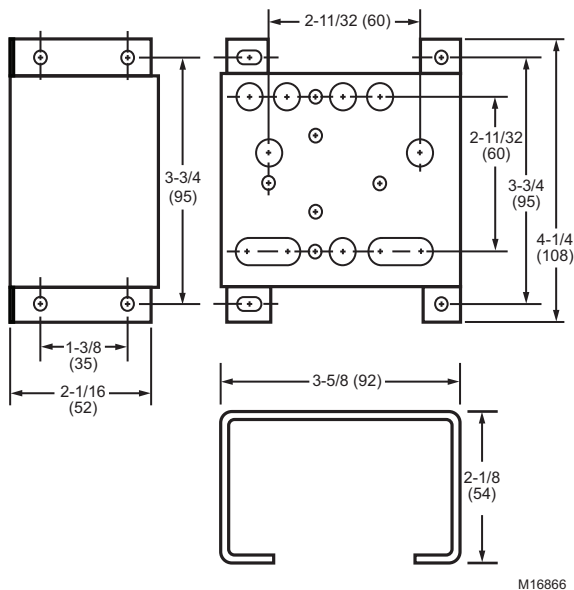

Fig. 3. 198545 Bracket dimensions in in. (mm).

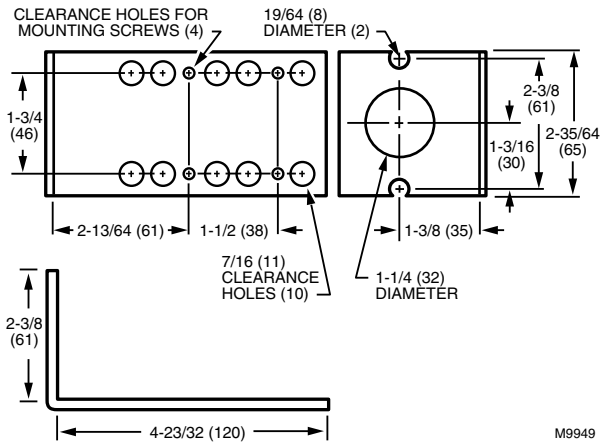

Fig. 4. 126809 Bracket dimensions in in. (mm).

INSTALLATION

When Installing this Product...

1. Read these instructions carefully. Failure to follow them could damage the product or cause a hazardous condition.
2. Check the ratings and descriptions given on the product to make sure the product is suitable for your application.
3. Installer must be a trained, experienced service technician.
4. After installation is complete, check out product operation as provided in this specification.



CAUTION

Electrical Shock Hazard.

Can cause severe injury, death or property damage.

1. Disconnect power supply before installation to prevent electrical shock or equipment damage.
2. To prevent damage to the gear train, never turn the motor shaft by hand or with a wrench.
3. Do not install the actuator in areas with acid fumes or other deteriorating vapors that might attack the metal parts of the motor.
4. Do not install the actuator in areas with escaping gas or other explosive vapors that could be ignited by a spark from the actuator or attached accessories.

Location and Mounting

IMPORTANT

Mount M436 and M836 Damper Motors with the shaft in the horizontal position.

Install the motor in a location where the ambient temperature range is within 32° to 125°F, free from acid fumes or other deteriorating vapors that might attack the metal parts of the

motor. Also, make sure the location is free from escaping gas or other explosive vapors that could be accidentally ignited by a spark from the motor or its attached parts.

Install the motor in a location that allows enough clearance for mounting accessories and for servicing.

Locate as near as possible to the equipment to be controlled. The 198545 Mounting Bracket and 7640JE Bag Assembly are for direct coupling to the damper shaft from either end of the motor, depending upon the desired rotational direction.

The 198545 Mounting Bracket may also be used for offset mounting with the 7640JL Bag Assembly and a standard damper linkage, such as Q605. 128336 Mounting Bracket must be used with 7640JL Bag Assembly and a standard damper linkage.

Mounting brackets and crankarm drives are furnished with TRADELINE® models of these motors or can be ordered separately if required for the installation. Refer to the Accessories section for specifications, Fig. 2 and 4 for dimensions, and Fig. 5 through 8 for installation drawings.

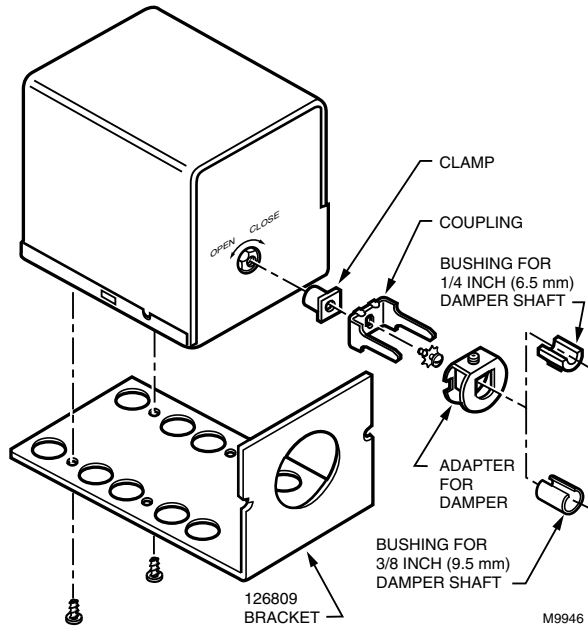
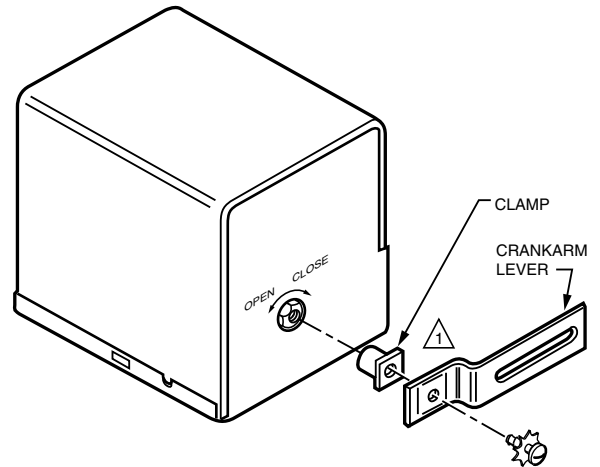
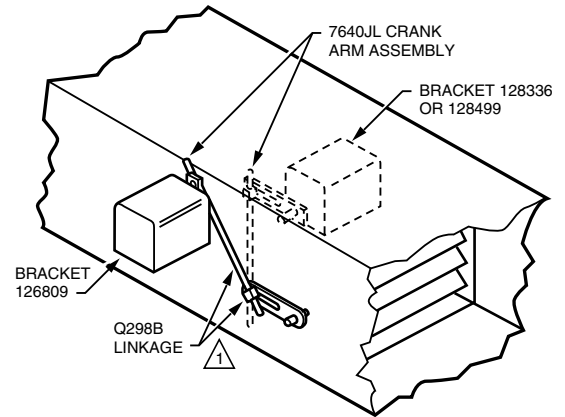

Fig. 5. Exploded view showing how to mount 7640JE Damper Shaft Coupling and 7640JM Mounting Bracket Assembly to motor.



1 CLAMP AND CRANKARM LEVER ARE DESIGNED TO FIT TIGHTLY TOGETHER. IF NECESSARY, TAP THESE PARTS TOGETHER PRIOR TO MOUNTING ON MOTOR TO ENSURE TIGHTNESS. M9945

Fig. 6. Exploded view showing how to mount 7640JL Crankarm Assembly to motor.



1 ASSEMBLE 7640JL CRANK ARM ASSEMBLY TO MOTOR AND Q298B LINKAGE TO DAMPER. ADJUST LENGTH OF STEEL ROD AS NECESSARY. ONE Q298B CRANK ARM IS NOT NECESSARY AND MAY BE DISCARDED. M9941

Fig. 7. Offset mounting with 7640JL Crankarm Assembly and Q298B Linkage.

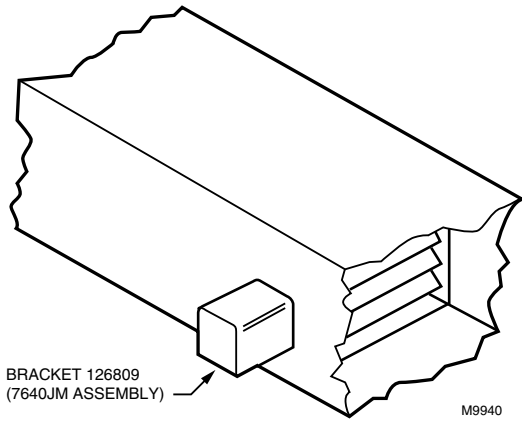

Fig. 8. Damper motor directly coupled to damper using 7640JM Mounting Bracket Assembly and 7640JE Drive Coupling Assembly.

Wiring

CAUTION

Electrical Shock Hazard.

Disconnect the power supply before wiring to prevent electrical shock or equipment damage.

Disconnect the power supply before beginning wiring to prevent electrical shock or equipment damage. All wiring must comply with local electrical codes, ordinances and regulations. Refer to Fig. 9 and 10 for typical hookup diagrams and to information furnished with the system equipment.

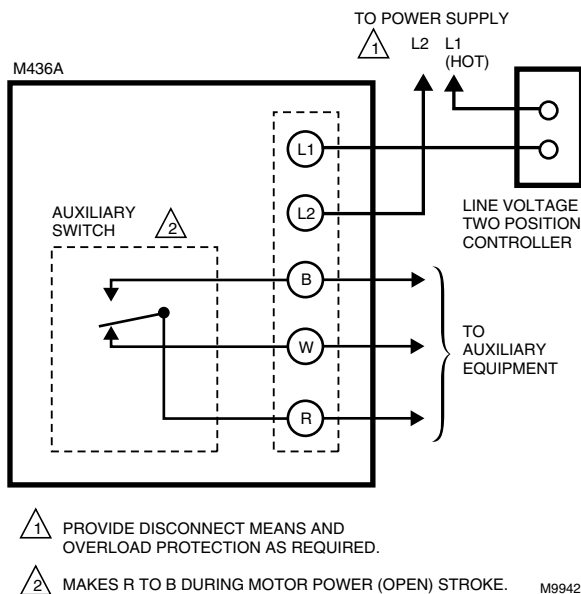

Fig. 9. Typical wiring diagram for M436 Damper Motor.

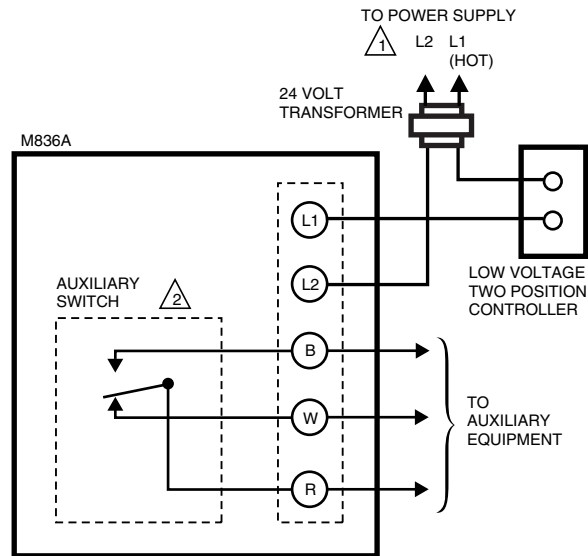

Fig. 10. Typical wiring diagram for M836 Damper Motor.

ADJUSTMENT AND CHECKOUT

Auxiliary Switch Adjustment

Adjust the internal spdt auxiliary switch of the M436/M836 Damper Motor to operate at any point between 5 degrees and 70 degrees of the motor stroke. The switch has a 1 to 2 degree nonadjustable differential. The switch makes R to B contact during the power stroke (motor shaft moves in the direction of the OPEN arrow on the outside of the case).

Apply power to the motor so that the motor runs to the OPEN position. Note the point of the motor stroke where the switch operates (audible click or check for continuity across the R to B terminals) If the switch operates correctly for the application, proceed to check out the installation. If the switch needs to be adjusted, perform the following steps:

1. Determine the number of degrees that the switch cam must be adjusted to operate the switch at the desired point of the motor stroke.

IMPORTANT

Do not adjust switch to operate closer than five degrees from the ends of the motor stroke.

2. Remove the motor cover.

CAUTION

Electrical Shock Hazard.

To prevent electrical shock or equipment damage, disconnect the power supply before adjusting the switch cam.

3. Insert a narrow bladed common-point screwdriver in a slot in the switch cam (white plastic) located near the center of the motor. Refer to Fig. 10. Each slot in the cam equals approximately 20 degrees of motor rotation.
4. Select a reference point and move the cam the correct number of degrees, as follows:
 - a. To adjust the switch to operate nearer the open (maximum rotation) motor position, move the cam in the direction of the CLOSE arrow on the outside of the motor case.
 - b. To adjust the switch to operate nearer the closed motor position, move the cam in the direction of the OPEN arrow on the outside of the motor case.

Repower the motor and check the point at which the switch makes and breaks. Readjust as necessary.

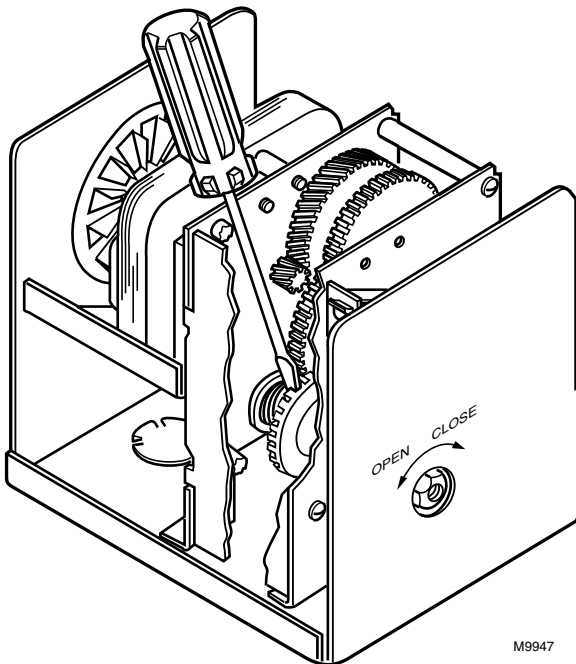

Fig. 11. Using screwdriver to adjust auxiliary switch cam.

Checkout

Operate the motor through the complete open-close stroke.

Be prepared to release one of the previously tightened linkage connections, if necessary, to prevent damage. Check for proper operation, making sure that the linkage does not bind

and that the motor travels smoothly through the fully open and fully closed positions. Cut any excess linkage rod length to the correct size.

Make necessary minor adjustments until desired operation is obtained and tighten all nuts and setscrews. A motor checkout should prove that:

1. The motor operates the load.
2. The motor responds properly to the controller.
3. There is no linkage binding or motor stalling at any point of travel.

If the motor does not operate properly, check for proper voltage or mechanical linkage or damper binding.

Lubrication

To assure long motor life, annually lubricate the felt pads located on each of the motor bearings and on the two shafts in the gear train. See Fig. 11. Use Anderol® 465 Oil or an equivalent. Light sewing machine oil is an acceptable equivalent. *Do not over lubricate. One drop at each lubrication point is sufficient.*

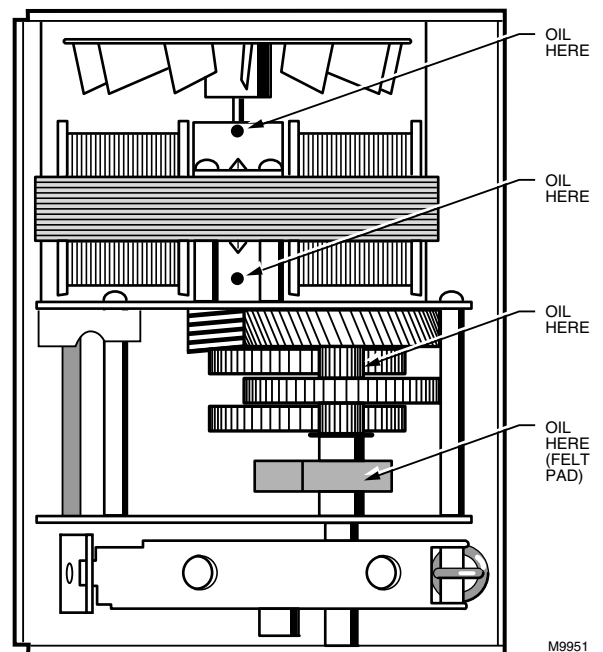

Fig. 12. M436/M836 Damper Motor lubrication points.

By using this Honeywell literature, you agree that Honeywell will have no liability for any damages arising out of your use or modification to, the literature. You will defend and indemnify Honeywell, its affiliates and subsidiaries, from and against any liability, cost, or damages, including attorneys' fees, arising out of, or resulting from, any modification to the literature by you.

Automation and Control Solutions

Honeywell International Inc.

Honeywell Limited-Honeywell Limitée

Honeywell