

M-12358

1

CONCENTRIC KNOCKOUTS

LOCATION	QUANTITY	TRADE SIZE
ENDS	1/END	3/4", 1", 1-1/4" SEE NOTE 7
ENDS	1/END	1/2", 3/4"
SIDES	2/SIDE	1/2", 3/4", 1"
BOTTOM	4	1/2", 3/4", 1"

LIST OF PARTS

DESCRIPTION	MATERIAL	FINISH
BOX ASSEMBLY	16 GA. STEEL	ZINC **
TOP MOUNTING ASSY	14 GA. STEEL	ZINC
TRANSITION ASSY	14 GA. STEEL	ZINC
GROUND WIRES	COPPER	
KNOCKOUT PLATES	16 GA. STEEL	ZINC
WIRING CHANNEL	16 GA. STEEL	ZINC
FASTENERS	STEEL	ZINC
TEMPORARY COVER	14 GA. STEEL	ZINC

** CATALOG NO. CFB2G30RCR BOX ASSEMBLY IS GALVANIZED AND EPOXY COATED ON EXTERIOR SURFACE.

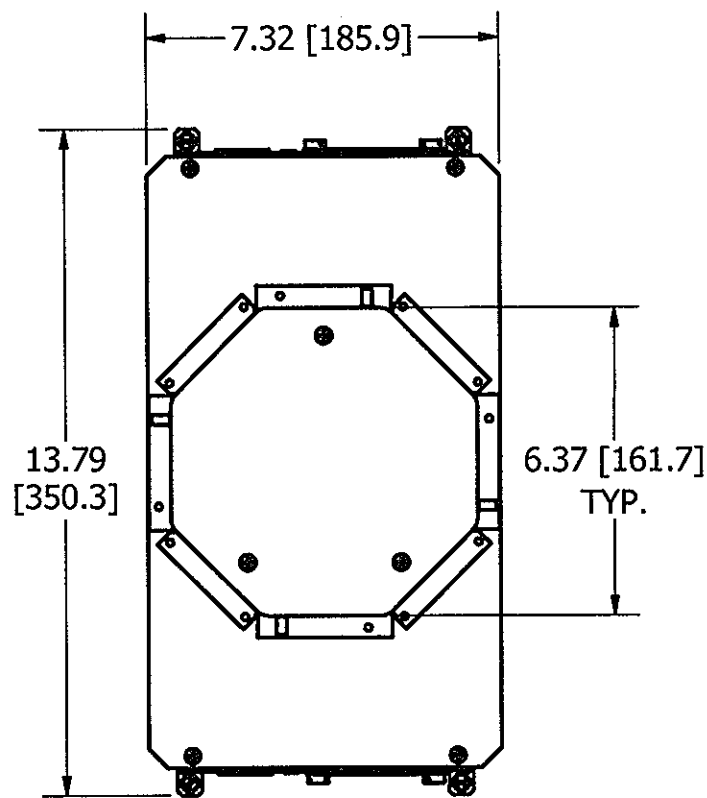

TOP VIEW

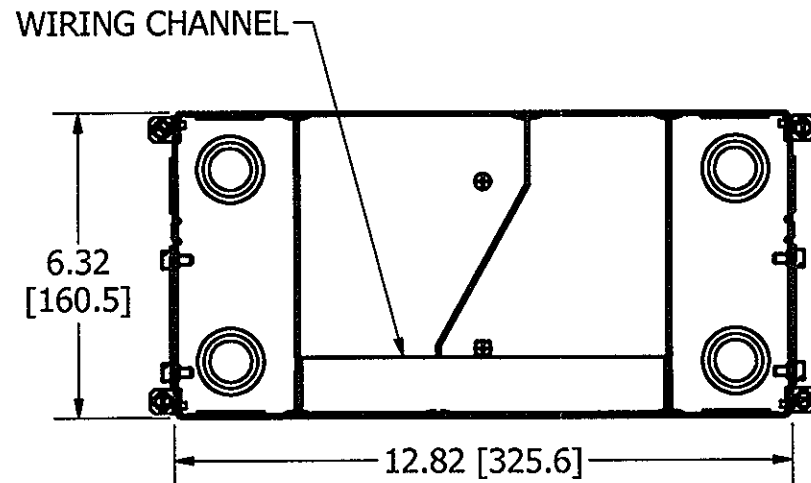

SECTION A-A
VIEW THROUGH BOX BELOW TRANSITION

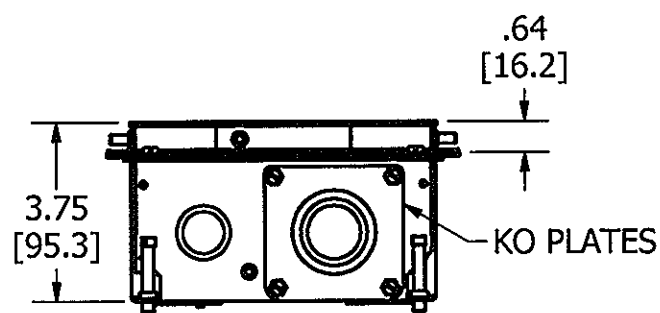

END VIEW

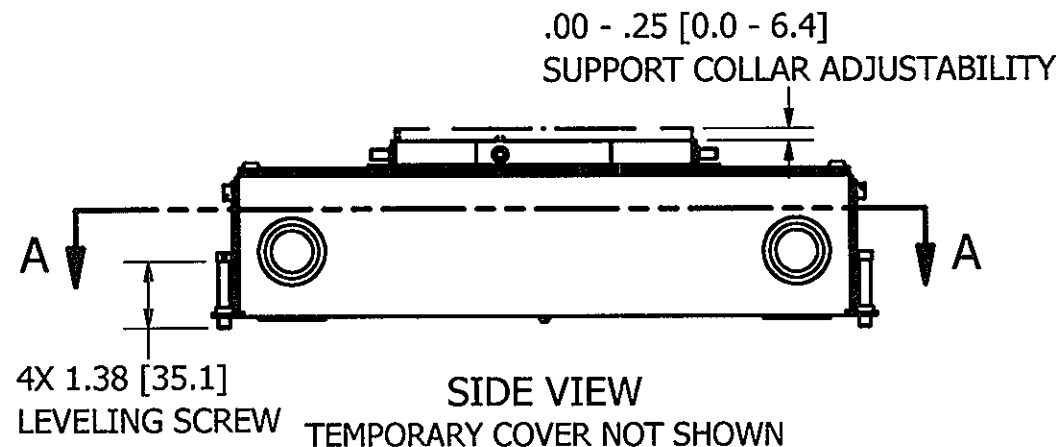

4X 1.38 [35.1] LEVELING SCREW
SIDE VIEW
TEMPORARY COVER NOT SHOWN

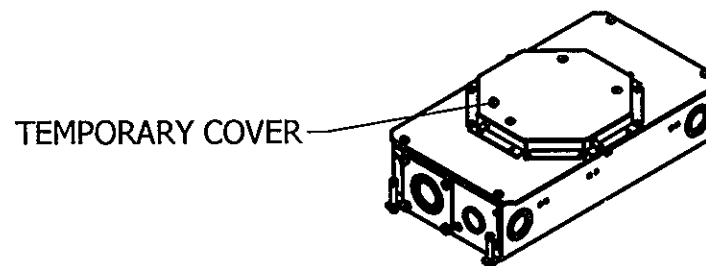

ISOMETRIC

- NOTES:
1. ALL DIMENSIONS ARE IN INCHES AND [MILLIMETERS].
 2. PRODUCT IS cULus LISTED. COMPLIES WITH UL 514A.
 3. EACH GANG SUPPLIED WITH 6" [152.4] 12 GA. AWG GROUND PIGTAIL.
 4. MINIMUM CONCRETE POUR: 3.75" [95.3].
 5. WIRING CHAMBER VOLUMES : (2) 35 IN³ [573.6 CM³].
 6. WIRING CHANNEL AREA: (2) .40 IN² [261 MM²].
 7. 2" TRADE SIZE CONDUIT HUBS (CFBHUB2) MAY BE USED IN PLACE OF SIDE KO PLATES, SOLD SEPARATELY.

1	INITIAL RELEASE PER DCN19233	SBW	11/15/13
SYM	DESCRIPTION	APP	DATE
	THE DESIGN AND DIMENSIONS OF THE PRODUCT SHOWN ON THIS DRAWING ARE SUBJECT TO CHANGE WITHOUT NOTICE		
TITLE CONCRETE FLOOR BOX, 2 GANG FOR 6" ROUND COVER, DEEP			
TOLERANCES UNLESS OTHERWISE SPECIFIED		WIRING DEVICE-KELLEMS HUBBELL INCORPORATED SHELTON, CT.	
.XX = ± .01	.XXX = ± .005	DR. BY	SBW APP. BY
ANGLES = ± 2°		TR. BY	SCALE 1/4
		CHK'D BY	SM DATE 9/19/2013