

| CATALOG | DESCRIPTION  |
|---------|--|
| HP5E24A | NEXTSPEED CATEGORY 5e, 24 PORT ANGLED PATCH PANEL, BLACK |
| HP624A  | NEXTSPEED CATEGORY 6, 24 PORT ANGLED PATCH PANEL, BLACK  |
| HP6A24A | NEXTSPEED CATEGORY 6A, 24 PORT ANGLED PATCH PANEL, BLACK |

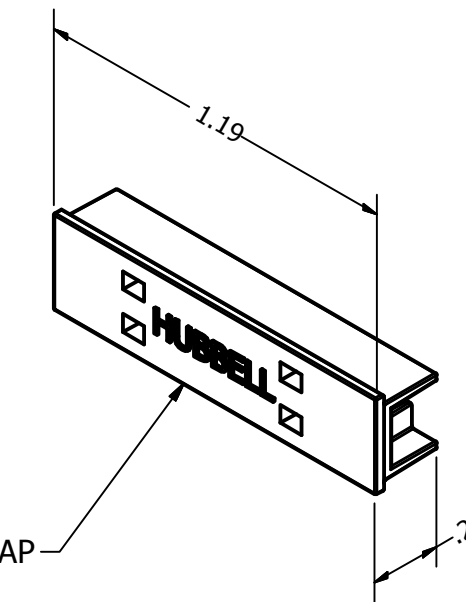

- NOTES:
- PRODUCT INCLUDES
    - (1) PATCH PANEL ASSEMBLY
    - (25) STUFFER CAPS
    - (1) CABLE MANAGER BAR
    - (4) LABEL CARDS
    - (4) CLEAR LABEL COVERS
    - (1) HARDWARE PACK
    - (1) INSTRUCTIONS
  - SPECIFICATIONS SUBJECT TO CHANGE WITHOUT NOTICE

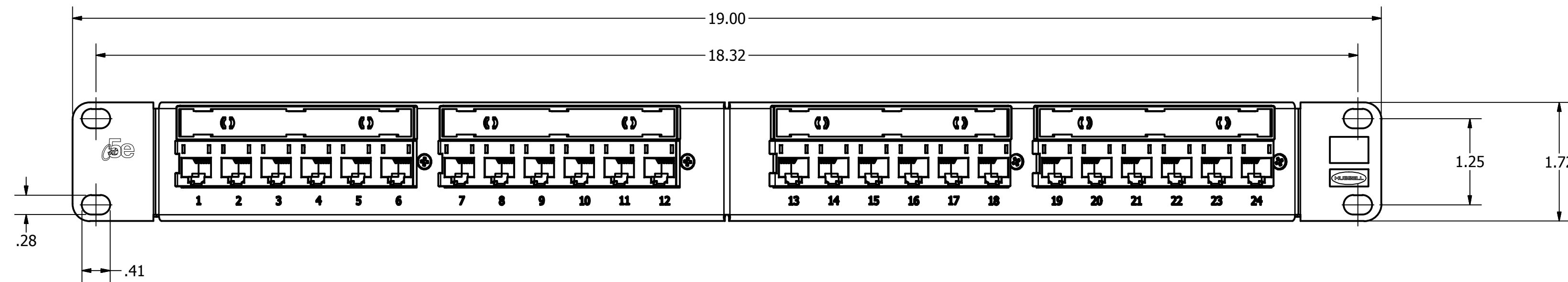
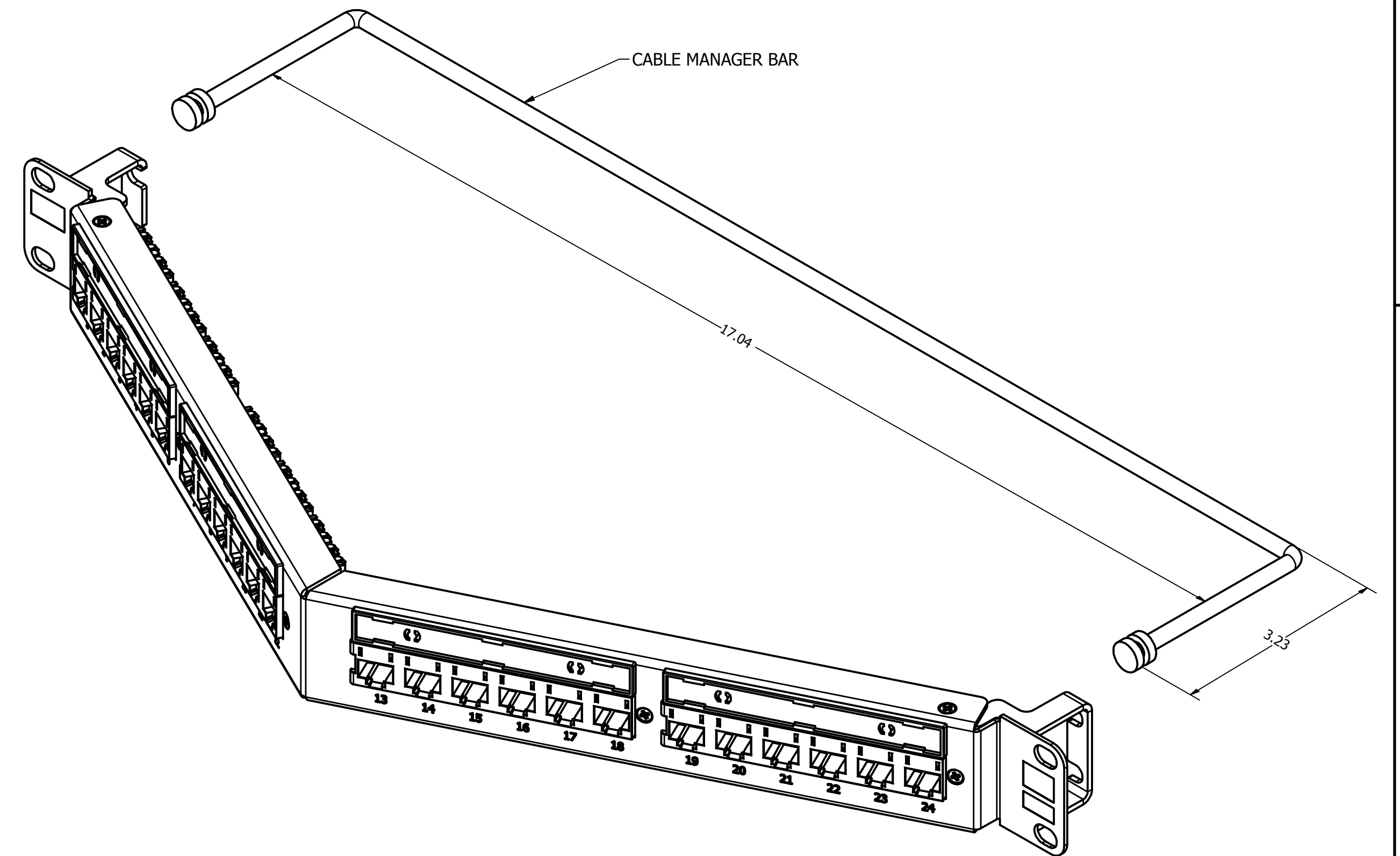
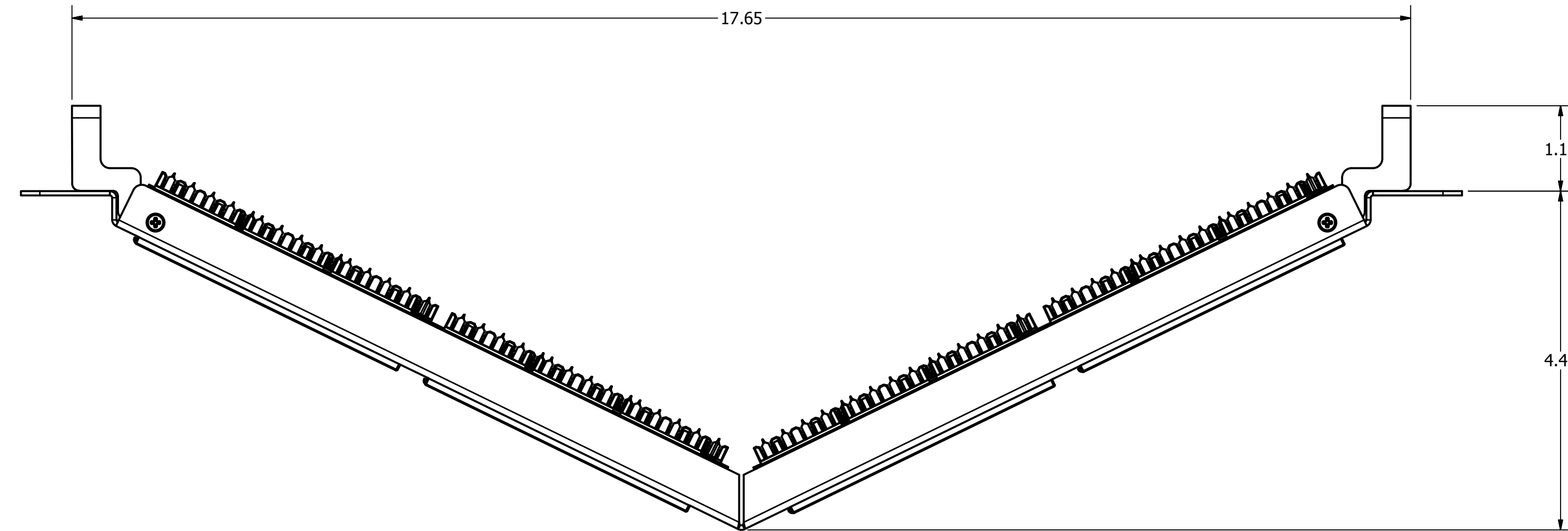
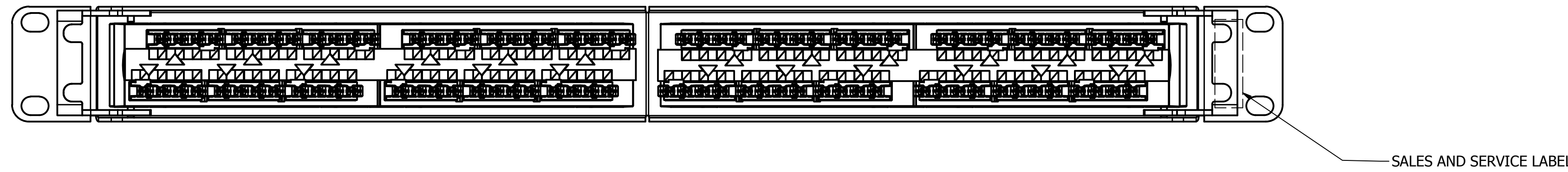

| REV. | ECN   | DATE    | DESCRIPTION     | CHG BY | APPD BY |
|------|-------|---------|-----------------|--------|---------|
| 1    | 17850 | 2/11/14 | INITIAL RELEASE | DPO    |         |

**Created on INVENTOR**

DIMENSIONING AND TOLERANCE PER ANSI Y14.5M-1982 UNLESS OTHERWISE SPECIFIED, DIMENSIONS ARE IN INCHES (MM). TOLERANCES: XX = ±.01 (.25) .XXX = ±.005 (.127) .XXXX = ±.0025 (.0635) ANGLE TOL ±1°

IN ACCEPTING OUR DRAWINGS, BLUEPRINTS, OR SUPPORTING DOCUMENTATION FOR QUOTATION OR OTHER PURPOSES, YOU AGREE NOT TO DISCLOSE TO OTHERS THE IDEAS, INFORMATION, OR DESIGNS SHOWN HEREIN, AND THAT YOU WILL MAKE NO USE OF SAME WITHOUT PERMISSION

|                                 |
|---------------------------------|
| PROJECT REFERENCE:<br>2013-017  |
| MATERIAL:                       |
| DRAWN BY:<br>D.O'CONNOR 2/11/14 |
| CHECKED BY:                     |
| APPROVED BY:                    |

**HUBBELL** Hubbell Premise Wiring  
HUBBELL INCORPORATED (Delaware)

TITLE:  
NEXTSPEED 24 PORT ANGLED PATCH PANEL

|                  |                                 |                  |
|------------------|---------------------------------|------------------|
| SIZE<br><b>D</b> | DRAWING NO.<br><b>HWS14352C</b> | REV.<br><b>1</b> |
| SCALE:<br>DNS    | SHEET<br>1 OF 1                 |                  |