

CATALOG	DESCRIPTION
HP5E48A	NEXTSPEED CATEGORY 5e, 48 PORT ANGLED PATCH PANEL, BLACK
HP648A	NEXTSPEED CATEGORY 6, 48 PORT ANGLED PATCH PANEL, BLACK
HP6A48A	NEXTSPEED CATEGORY 6A, 48 PORT ANGLED PATCH PANEL, BLACK

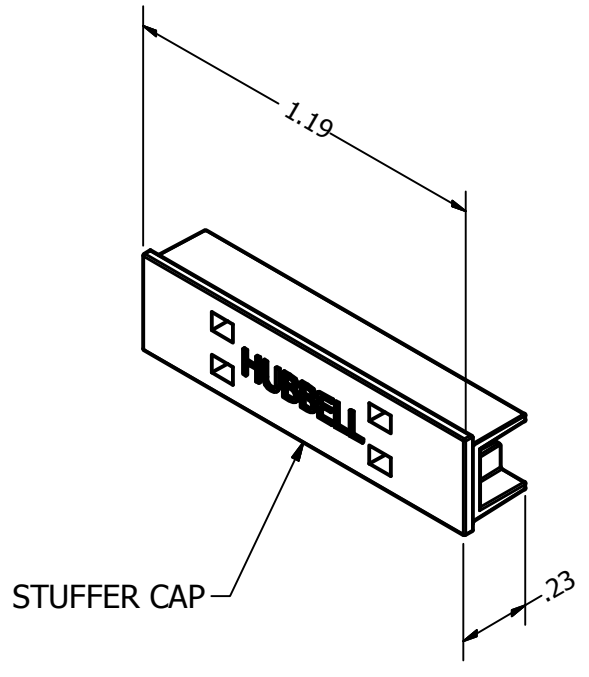
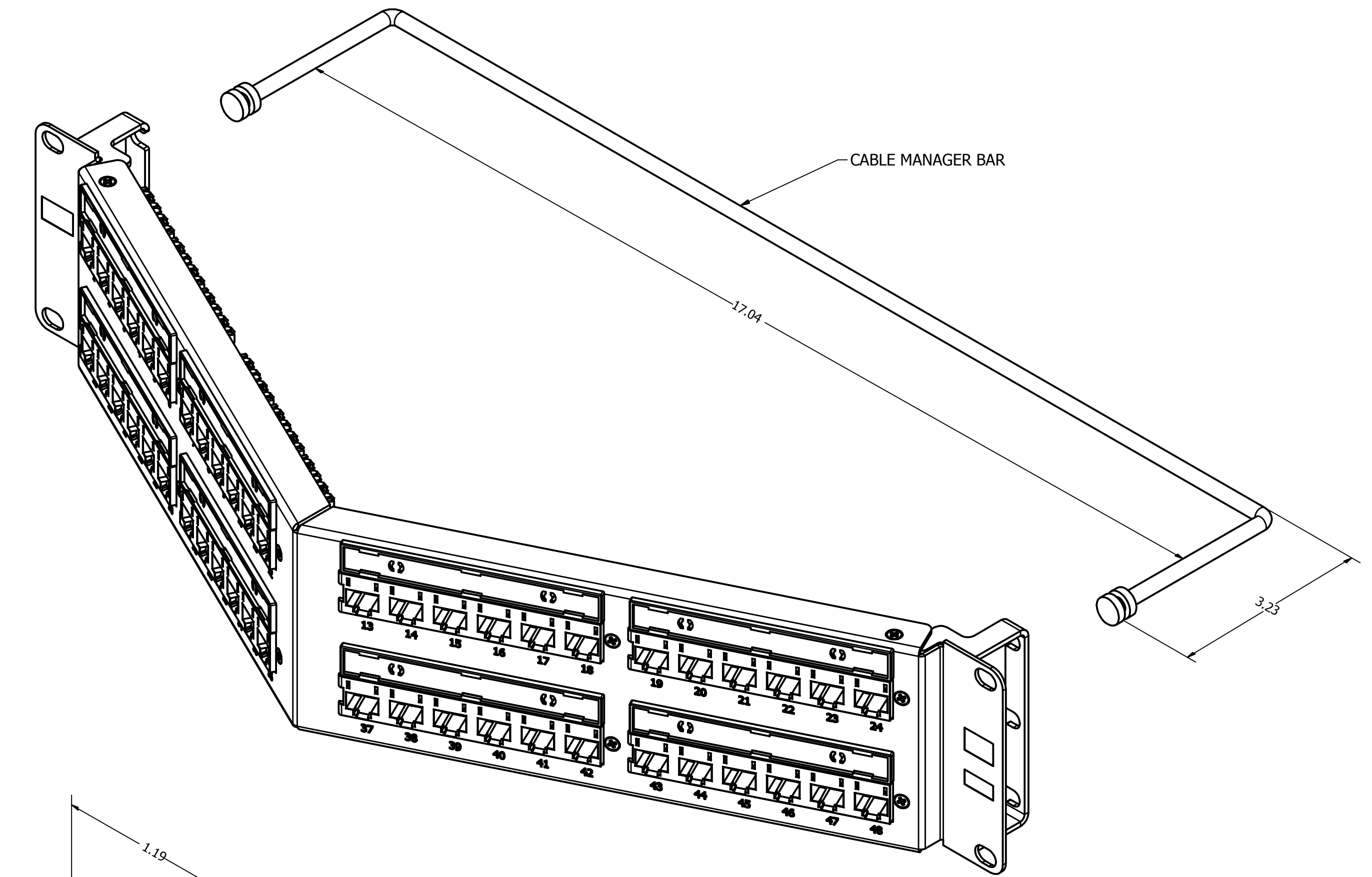
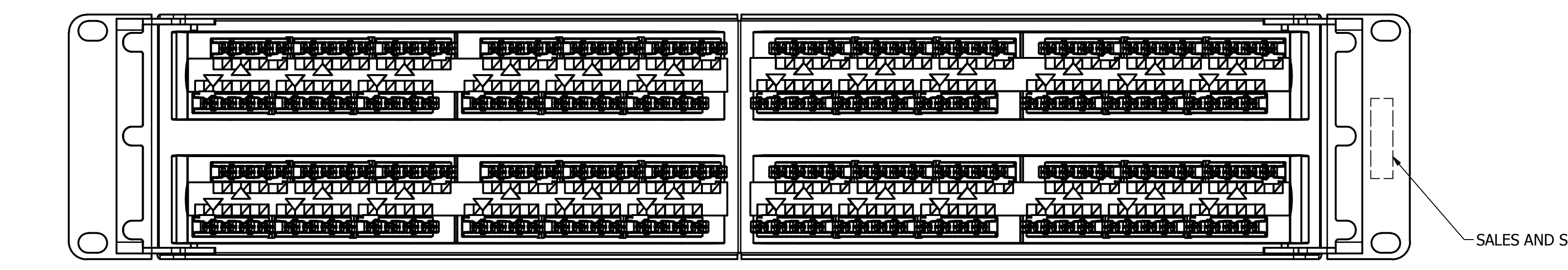
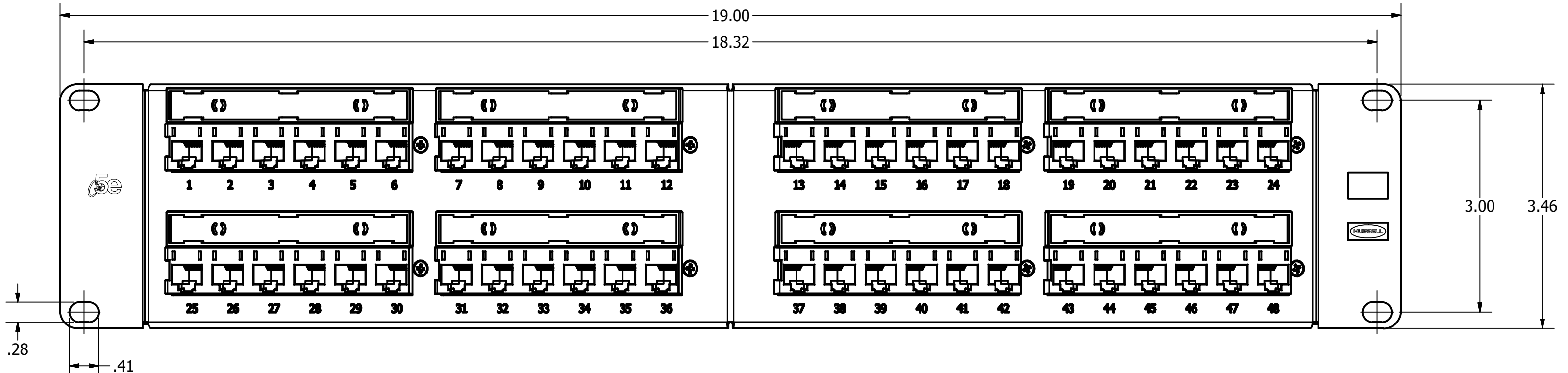
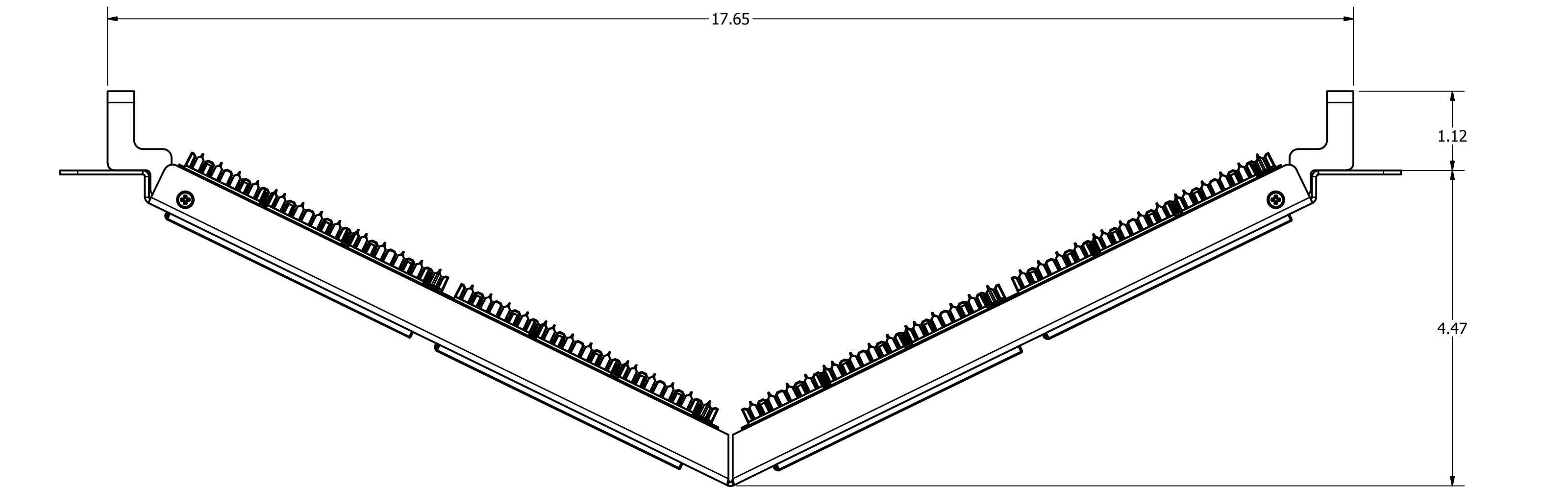
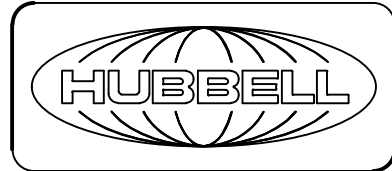

- NOTES:
- PRODUCT INCLUDES
 - (1) PATCH PANEL ASSEMBLY
 - (50) STUFFER CAPS
 - (2) CABLE MANAGER BARS
 - (8) LABEL CARDS
 - (8) CLEAR LABEL COVERS
 - (1) HARDWARE PACK
 - (1) INSTRUCTIONS
 - SPECIFICATIONS SUBJECT TO CHANGE WITHOUT NOTICE

Created on INVENTOR	DIMENSIONING AND TOLERANCE PER ANSI Y14.5M-1982 UNLESS OTHERWISE SPECIFIED, DIMENSIONS ARE IN INCHES (MM). TOLERANCES: XX = ±.01 (.25) .XXX = ±.005 (.127) .XXXX = ±.0025 (.0635) ANGLE TOL ±1°		PROJECT REFERENCE: 2013-017		 Hubbell Premise Wiring HUBBELL INCORPORATED (Delaware)
	IN ACCEPTING OUR DRAWINGS, BLUEPRINTS, OR SUPPORTING DOCUMENTATION FOR QUOTATION OR OTHER PURPOSES, YOU AGREE NOT TO DISCLOSE TO OTHERS THE IDEAS, INFORMATION, OR DESIGNS SHOWN HEREIN, AND THAT YOU WILL MAKE NO USE OF SAME WITHOUT PERMISSION		DRAWN BY: D.O'CONNOR 2/11/14		
	REV. ECN DATE DESCRIPTION CHG BY APPD BY		CHECKED BY:		SIZE DRAWING NO. REV.
	1	17850	2/11/14	INITIAL RELEASE	DPO
				APPROVED BY:	SCALE: DNS SHEET 1 OF 1

REV.	ECN	DATE	DESCRIPTION	CHG BY	APPD BY
1	17850	2/11/14	INITIAL RELEASE	DPO	