

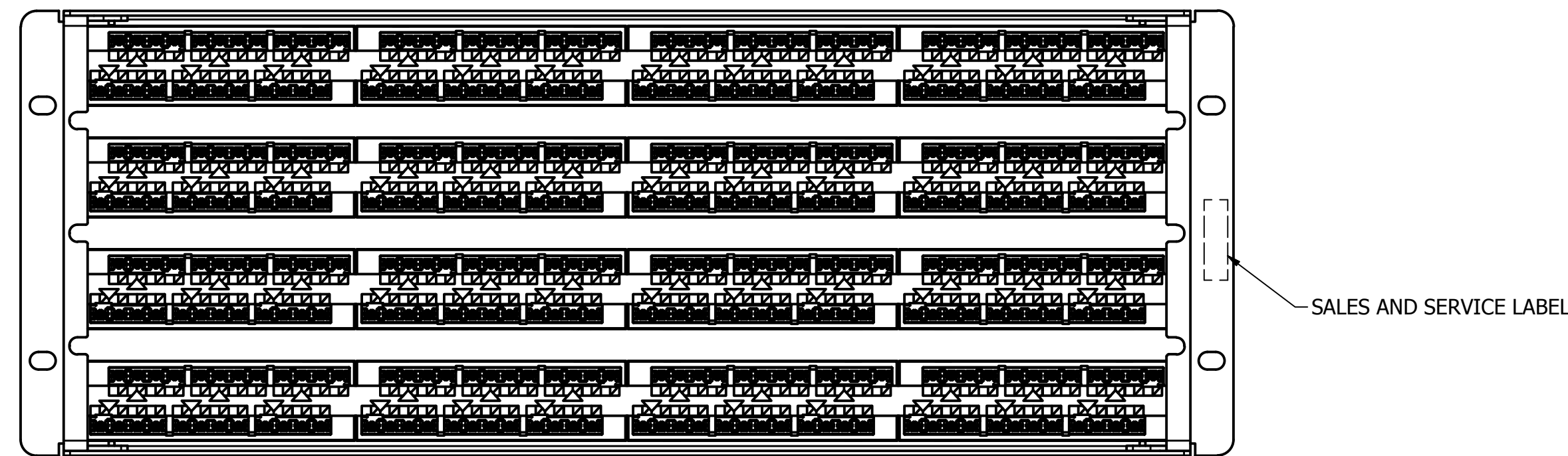

CATALOG	DESCRIPTION
HP5E96	NEXTSPEED CATEGORY 5e, 96 PORT PATCH PANEL, BLACK
HP696	NEXTSPEED CATEGORY 6, 96 PORT PATCH PANEL, BLACK
HP6A96	NEXTSPEED CATEGORY 6A, 96 PORT PATCH PANEL, BLACK

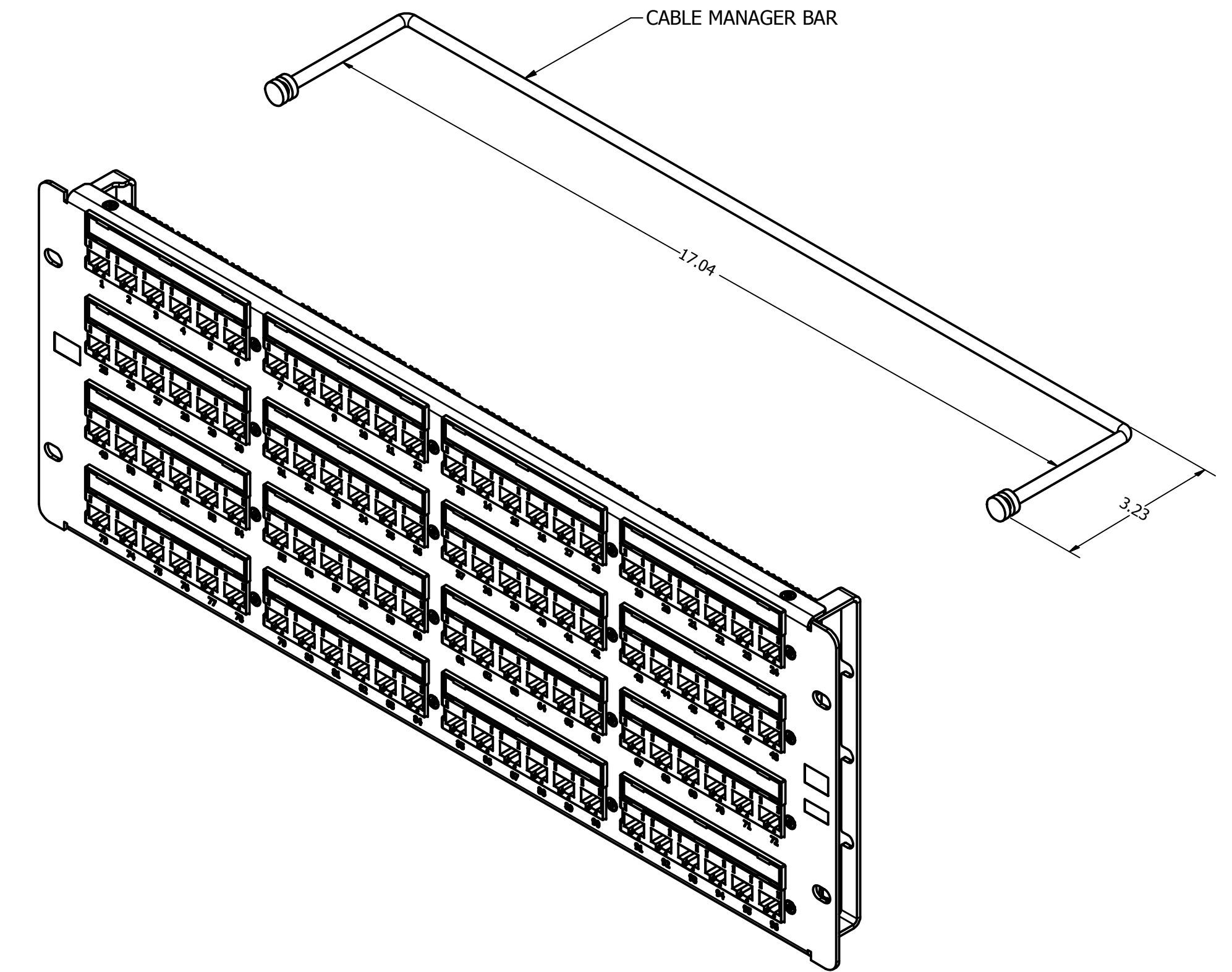
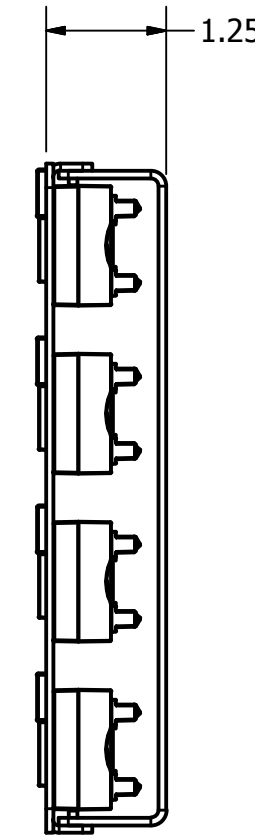
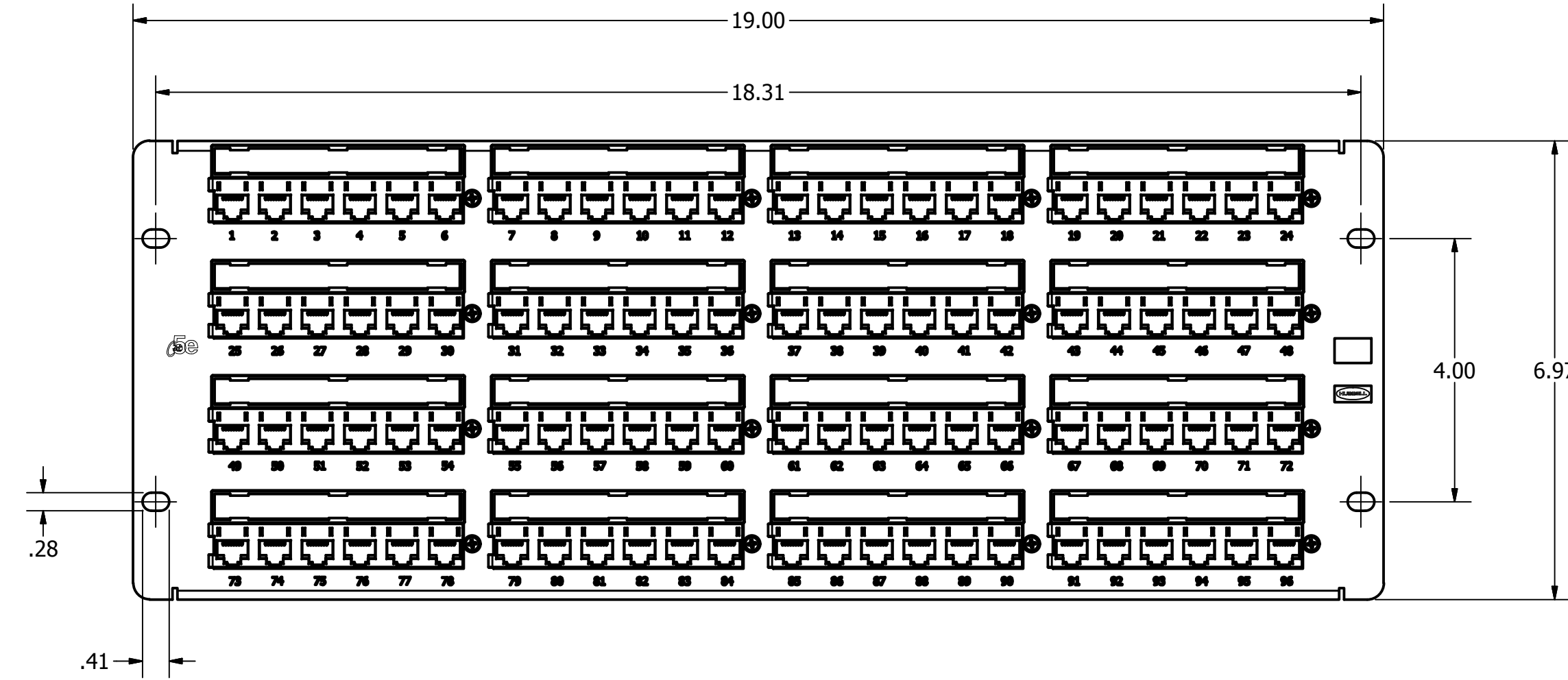
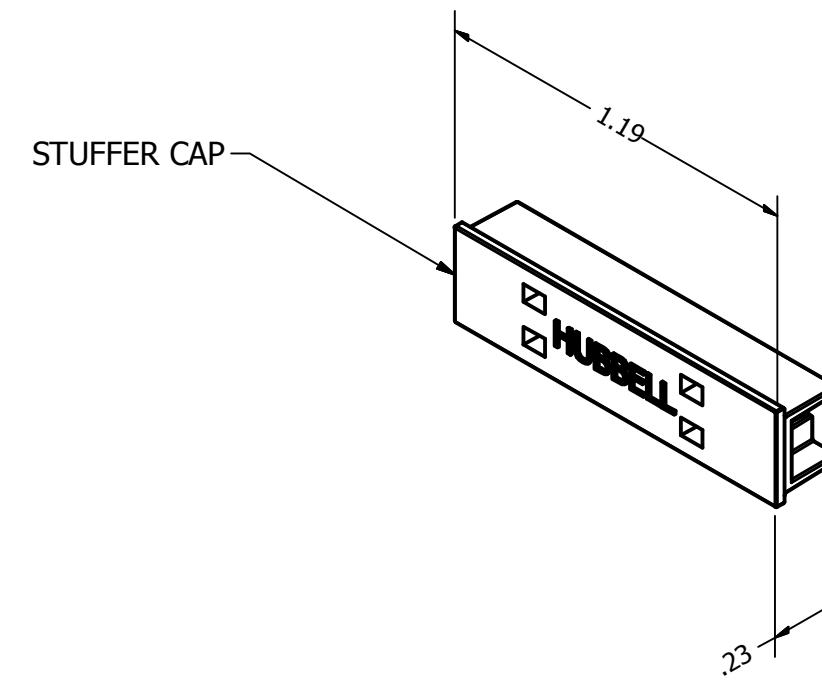

NOTES:

- PRODUCT INCLUDES
 - (1) PATCH PANEL ASSEMBLY
 - (100) STUFFER CAPS
 - (16) LABEL CARDS
 - (16) CLEAR LABEL COVERS
 - (3) CABLE MANAGER BARS
 - (1) HARDWARE PACK
 - (1) INSTRUCTIONS
- SPECIFICATIONS SUBJECT TO CHANGE WITHOUT NOTICE

Created on INVENTOR	DIMENSIONING AND TOLERANCE PER ANSI Y14.5M-1982, UNLESS OTHERWISE SPECIFIED, DIMENSIONS ARE IN INCHES (MM). TOLERANCES: XX = ±.01 (.25), .XXX = ±.005 (.127), .XXXX = ±.0025 (.0635), ANGLE TOL ±1°		PROJECT REFERENCE: 2013-017		 Hubbell Premise Wiring HUBBELL INCORPORATED (Delaware)		
	IN ACCEPTING OUR DRAWINGS, BLUEPRINTS, OR SUPPORTING DOCUMENTATION FOR QUOTATION OR OTHER PURPOSES, YOU AGREE NOT TO DISCLOSE TO OTHERS THE IDEAS, INFORMATION, OR DESIGNS SHOWN HEREIN, AND THAT YOU WILL MAKE NO USE OF SAME WITHOUT PERMISSION		MATERIAL:			TITLE: 96 PORT PATCH PANEL	
			DRAWN BY: D.O'CONNOR 2/11/14		SIZE D	DRAWING NO. HWS14171C	REV. 1
			CHECKED BY:		SCALE: DNS SHEET 1 OF 1		

REV.	ECN	DATE	DESCRIPTION	CHG BY	APPD BY
1	17850	2/11/14	INITIAL RELEASE	DPO	