

Twist-Lock® Devices  
 30A, 3 Phase 250V AC, 3 Pole, 4 Wire  
 Grounding  
 Watertight Safety-Shroud® Flanged Inlet

# HUBBELL

## Features

- One-piece, engineered thermoplastic housing is impact-resistant for heavy-duty industrial environments
- Alignment arrows and lock and unlock symbols provide a visual indication that devices are properly connected.
- Closure cap is included for environmental seal when device is not in use
- Catalog number and color-coded voltage rating are easily visible even when in use

## Ordering Information

Description	Device Color	UPC	Catalog Number
Gray PBT housing and flange.	Gray	783585231884	HBL2725SW

## Listings

Listed to UL 498  
 Fed.Spec. W-C-596  
 Certified to CSA C22.2 No.42  
 UL Listed, CSA Certified to Type 4, 4X and Type 12

## Specifications

Housing / Flange	Gray PBT
Terminal Retainer	Clear polycarbonate
Blades	Brass
Terminal Screws	#10-32 Brass (Phillips / Slotted / Robertson)
Assembly Screws	Stainless Steel
Mounting Sscrew	Stainless Steel

## Performance

Electrical	
Current Interrupting	Certified for current interrupting at full rated current
Dielectric Voltage	Withstands 2,000V minimum
Mechanical	
Terminal Accommodation	#16 AWG - #8 AWG solid or stranded copper wire only.
Terminal Identification	Terminals identified in accordance with UL 498
Environmental	
Flammability	V0 per UL94 or CSA 22.2 No.0.17
Moisture Resistance	Type 4, 4X, 12, IP66 suitability
Operating Temperatures	Maximum Continuous 75°C; Minimum -40°C (w/o impact)



30A 3Ø 250V AC  
 NEMA L15-30P  
 UL/CSA  
 3 HP

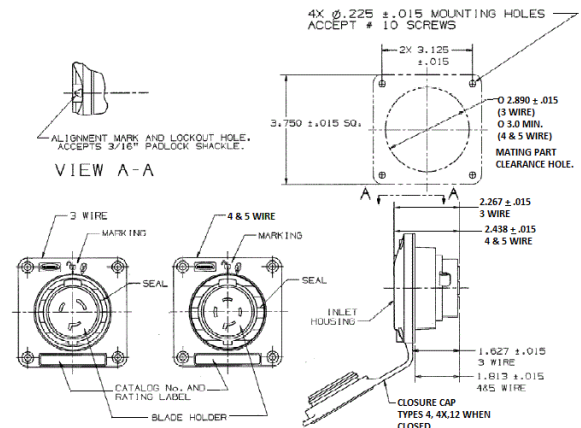

## Accessories

Watertight Safety Shroud Connector	HBL2723SW
Non-Metallic Backbox	BB2030N
2-Gang Weatherproof Box Adapter Plate	HBL2030AP

## Resources

Customer Use Drawing  
 eCatalog

Dimensions in Inches (mm)

Specifications subject to change without notice.

