

Switched Disconnects and Enclosures
Non-Metallic Replacement Covers

HUBBELL

Features

- Constructed from corrosion and impact resistant UV stabilized non-metallic material
- IP69k and Type 4X,12K water ingress protection
- Certified by NSF for hygiene in food processing applications
- Highly visible red handle which meets OSHA Lockout/Tagout capabilities
- Reversible interior accomodates top or bottom conduit opening

Ordering Information

Description	UPC Number	Catalog Number
60A Replacement Cover for Disconnect Switch	783585912455	HBLDS6RC



Specifications

Cover	PBT
Handle	PBT
Cover & Handle Screw	Stainless Steel

Performance

Electrical	
Current Interrupting	Certified for current interrupting at full rated current and voltage
Dielectric Voltage Max. Working Voltage	Withstands 3000V AC minimum 600V AC RMS
Mechanical	
Impact Resistance	In accordance with UL 746C
Mounting	External fully adjustable feet
Terminal Identification	In accordance with UL, CSA and international conventions
Environmental	
Flammability	UL94-5VA and V0 Classification
Indoor and Outdoor – Type 4X (Wash down, Corrosion resistant); Indoor – Type 12 (Dust-tight, Falling Dirt, Noncorrosive Liquids).	Max. Continuous: 75°C; Min. Continuous: -40°C without impact
Moisture Resistance	Indoor and Outdoor – Type 4X (Wash down, Corrosion resistant); Indoor – Type 12 (Dust-tight, Falling Dirt, Noncorrosive Liquids).
Operating Temperature	Max. Continuous: 75°C; Min. Continuous: -40°C without impact

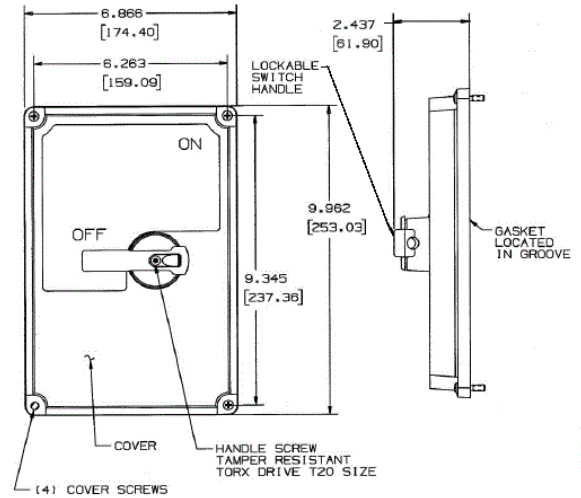

Complementary Products

Non-Metallic Labelless Circuit-Lock® Switched Disconnect Enclosures	HBLDS6; HBLDS6VFD; HBLDS6AC
---	--------------------------------

Online Resources

- Customer Use Drawing
- eCatalog
- Installation Instructions

Dimensions in Inches (mm)

Specifications subject to change without notice.

