

## Countertop Receptacles

### 15A 125v Tamper-Resistant Pop-Up Counter Receptacle

# HUBBELL

#### Features

- Spill water tested
- Permanent installation ready (suitable for MC cable or non-metallic sheath cable)
- Push down to pop-up function is rated for a minimum of 10,000 cycles
- Easy installation - simply drop in and tighten

#### Ordering Information

| Description  | Finish        | UPC Number   | Flush Mount |
|--|---------------|--------------|-------------|
| 15A 125V Tamper-Resistant Pop-Up Kitchen Counter Receptacle, Flush Mount | Powder Coated | 883778308000 | RCT201W     |

#### Color/Material

White

#### Listings

UL and cULus listed to UL498, Section 146

#### Specifications

|                  |                              |
|------------------|------------------------------|
| Cover and Flange | Die Cast Aluminum            |
| Main Body        | Engineered Thermoplastic PBT |
| Wiring Chamber   | Die Cast Aluminum            |
| Water Seals      | Elastomers and Silicon       |

#### Performance

| Electrical              |  |
|-------------------------|--|
| Configuration           | 15 amp 125 volt, Tamper Resistant Receptacle           |
| Circuit Rating          | 20 amp non-feed through                                |
| Dielectric Voltage      | Withstands 2,000V minimum                              |
| Mechanical              |  |
| Terminal Accommodation  | #12 AWG copper stranded or solid conductor only        |
| Terminal Identification | Terminals identified in accordance with UL 498 and CSA |
| Environmental           |  |
| Flammability            | UL 94V-2   |
| Operating Temperature   | Maximum continuous 75°C, minimum -40°C (w/o impact)    |

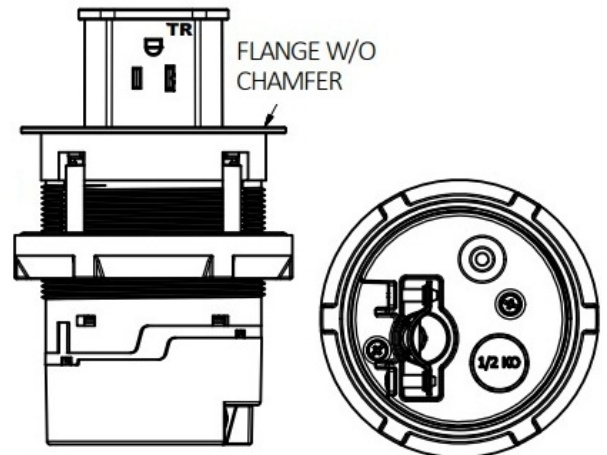

#### Online Resources

Customer Use Drawing  
eCatalog  
Installation Instructions

Dimensions in Inches (mm)

Specifications subject to change without notice.

