

Countertop Receptacles

20A 125v Tamper-Resistant Pop-Up Counter Receptacle

HUBBELL

Features

- Spill water tested
- Permanent installation ready (suitable for MC cable or non-metallic sheath cable)
- Push down to pop-up function is rated for a minimum of 10,000 cycles
- Easy installation - simply drop in and tighten

Ordering Information

Description	Finish	UPC Number	Surface Mount
20A 125V Tamper-Resistant Pop-Up Kitchen Counter Receptacle	Powder Coated	883778309533	RCT220W

Color/Material

White

Listings

UL and cULus listed to UL498, Section 146

Specifications

Cover and Flange	Die Cast Aluminum
Main Body	Engineered Thermoplastic PBT
Wiring Chamber	Die Cast Aluminum
Water Seals	Elastomers and Silicon

Performance

Electrical	
Configuration	20 amp 125 volt, Tamper Resistant Receptacle
Circuit Rating	20 amp non-feed through
Dielectric Voltage	Withstands 2,000V minimum
Mechanical	
Terminal Accommodation	#12 AWG copper stranded or solid conductor only
Terminal Identification	Terminals identified in accordance with UL 498 and CSA
Environmental	
Flammability	UL 94V-2
Operating Temperature	Maximum continuous 75°C, minimum -40°C (w/o impact)

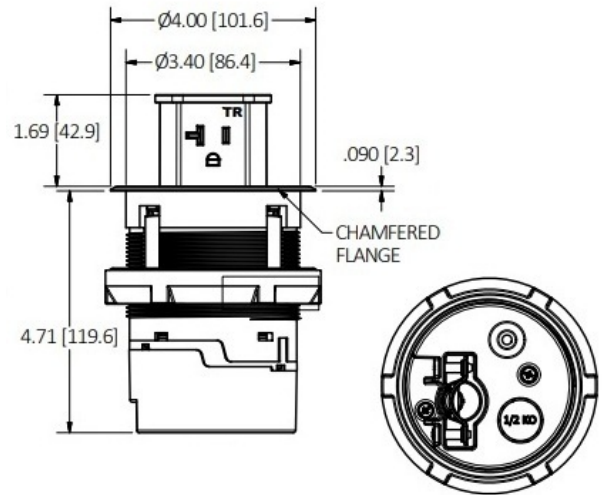

Online Resources

Customer Use Drawing
eCatalog
Installation Instructions

Dimensions in Inches (mm)

Specifications subject to change without notice.

