

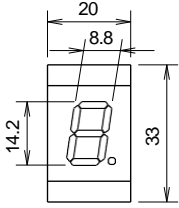

Series	DD3S	
Shape		
Unit Type	Decimal/Hexadecimal/Extra Decimal	
Display Part (mm)	 <p>7-segment Red LED, Green LED</p>	
Display Character	Decimal display unit: 0 to 9, decimal point Hexadecimal display unit: 0 to F, decimal point Extra decimal display unit: 0 to 9, -, ., =, decimal point	
Function	Standard	Zero-suppress
Input	Binary Latch BL LT DP	Binary Latch BL LT RBI DP
Output	—	RBO
Input Logic	Positive or negative	
Data Input Level	L: 0 to 2V H: 9 to 30V	
Power Voltage	12 to 24V DC ±10%	
Current Draw (Power Consumption) (approx.)	Red: 40 mA max. Green: 40 mA max.	
No. of Digits	8 digits max. (1 digit/unit)	
Panel Mounting	Front mount, snap fit	
Housing Color	Black (End plate: black)	
Connector	Solder terminal, PC board terminal, wire-wrap terminal (optional) Mother board: Dynamic (4- or 2-digit, optional) Static (4-, 3-, or 2-digit, optional) Mother board: 4 digits (optional)	
Dimensions	33H × 20W × 45.5D mm/unit	
Weight (approx.)	Display unit: 16.0g End plates (pair): 4.5g	
See Page	2 to 14	

	DD96
	
	Decimal
	
	7-segment Red LED
	0 to 9 Decimal point
	—
	Binary Latch DP BI
	BO
	Negative
	L: 0 to 2V H: 12 to 30V
	24V DC ±10%
	80 mA
	8 digits max. (1 digit/unit)
	Front mount: Snap fit Rear mounting: Screw mounting
	Black
	Solder terminal (supplied)
	Front mount: 96H × 72W × 42.5D mm/unit Rear mount: 90H × 72W × 41D mm/unit
	Front mount: 130g Rear mount: 100g End plates: 26g (pair)
	15 to 19

# DD3S Series Display Units

## 7-segment digital display

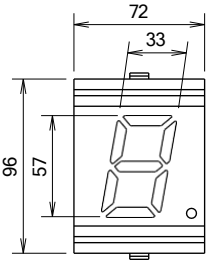
### Super bright LED display and short body for up to 8 digits

- Super bright LED for easy reading
- Units can be combined together and installed into a panel cut-out.
- Decimal, hexadecimal, extra decimal display units are available.
- Positive or negative input logic
- Easy wiring and maintenance
- Power voltage 12 through 24V DC.
- Mother boards are available for dynamic and static display modes; substantial saving of wiring.



## DD3S

Display Units (Housing Color: Black)

Notation	Function	Input Logic	LED Color	Part No.
Decimal	Standard	Positive	Red	DD3S-F31P-R
			Green	DD3S-F31P-G
		Negative	Red	DD3S-F31N-R
			Green	DD3S-F31N-G
	Zero-suppress	Positive	Red	DD3S-F31P-R-S
			Green	DD3S-F31P-G-S
Zero-suppress	Negative	Red	DD3S-F31N-R-S	
		Green	DD3S-F31N-G-S	
Extra Decimal	Standard	Positive	Red	DD3S-F34P-R
			Green	DD3S-F34P-G
		Negative	Red	DD3S-F34N-R
			Green	DD3S-F34N-G
	Zero-suppress	Positive	Red	DD3S-F34P-R-S
			Green	DD3S-F34P-G-S
Zero-suppress	Negative	Red	DD3S-F34N-R-S	
		Green	DD3S-F34N-G-S	
Hexadecimal	Standard	Positive	Red	DD3S-F36P-R
			Green	DD3S-F36P-G
		Negative	Red	DD3S-F36N-R
			Green	DD3S-F36N-G
	Zero-suppress	Positive	Red	DD3S-F36P-R-S
			Green	DD3S-F36P-G-S
Zero-suppress	Negative	Red	DD3S-F36N-R-S	
		Green	DD3S-F36N-G-S	

## Ordering Information

1. Specify the Part No. and quantity of the display units and accessories.

(Example) Display Unit	DD3S-F31P-R	8 pcs
Accessories		
• Spacer Unit	DD9Z-FY1-B	1 pc
• End Plate	DD9Z-W-B	1 set
• Mother Board	DD9Z-MB1-4	2 pcs

2. Order spacer units, end plates, and mother boards separately. See the next page.

3. Make sure to attach an endplate at the end of a connected unit and a connector or a motherboard to the terminal part.

## Accessories (Optional)

Name		Part No.	
Spacer Unit	Black	DD9Z-FY1-B	
End Plate (pair)	Black	DD9Z-W-B	
Connector	Solder Terminal	DMC-1	
	PC Board Terminal	DMC-2	
Retentive/One-way Insertion Connector	Solder Terminal	DD9Z-CN1	
Connector Stopper		DD9Z-ST1	
Mother Board for decimal/hex/extra decimal display unit	Dynamic	4-digit	DD9Z-MB1-4
		2-digit	DD9Z-MB1-2
	Static	4-digit	DD9Z-MB2-4
		3-digit	DD9Z-MB2-3
		2-digit	DD9Z-MB2-2

## Cable Length Code

Specify a cable length code in place of □ in the Part No. of mother board cable types A, B, and C. These cables can be used for both dynamic and static type mother boards.

Code	01	02	03	05	10
Cable Length (mm)	100	200	300	500	1000
Code	15	20	30	40	50
Cable Length (mm)	1500	2000	3000	4000	5000

## Specifications

Power Voltage	12 to 24V DC ±10%	
Current Draw	Decimal/Hex/Extra decimal	40 mA max. (red) 40 mA max. (green)
	Data Input Level	L: 0 to 2V H: 9 to 30V
Display Character (see Function Tables)	Decimal display unit 7-segment 1-color (red or green) LED: 0 to 9, decimal point Extra decimal display unit 7-segment 1-color (red or green) LED: 0 to 9, $\bar{\phantom{0}}$ , $\bar{\phantom{1}}$ , $\bar{\phantom{2}}$ , $\bar{\phantom{3}}$ , $\bar{\phantom{4}}$ , $\bar{\phantom{5}}$ , $\bar{\phantom{6}}$ , $\bar{\phantom{7}}$ , $\bar{\phantom{8}}$ , $\bar{\phantom{9}}$ , decimal point Hexadecimal display unit 7-segment 1-color (red or green) LED: 0 to 9, A to F, decimal point	
Character Height	Decimal/Hex/Extra Decimal display units: 14.2 mm	
Input	Decimal/Hex/Extra Decimal display units: <Standard> Binary, Latch, BL, LT, DP <Zero-suppress> Binary, Latch, BL, LT, DP, RBI	
Output	Decimal/Hex/Extra Decimal display units: <Zero-suppress> RBO output	
Input Logic	Positive or negative	
No. of Digits	8 digits max.	
Unit Combination	Snap fit	
Panel Mounting	Snap fit	
Dielectric Strength	Decimal/Hex/Extra decimal display units Between live and dead parts : 1500V DC, 1 minute	
Insulation Resistance	Between live and dead parts : 100 MΩ min. (500V DC megger)	
Vibration Resistance (damage limits)	10 to 55 Hz, amplitude 0.25 mm	
Shock Resistance (damage limits)	490 m/s <sup>2</sup>	
Noise Resistance (operating extremes)	Decimal/Hex/Extra decimal display unit Power terminal (normal/common modes): ±1000V Input terminal (normal/common modes): ±1000V Output terminal (normal/common modes): ±500V (Impulse condition: Pulse width 100 ns, 1 μs)	
Operating Temperature	-10 to +55 °C (no freezing)	
Storage Temperature	-25 to +80 °C (no freezing)	
Operating Humidity	35 to 85% RH (no condensation)	
Power Inrush Current	Decimal/Hex/Extra decimal display unit Approx. 0.3A (Power voltage: 24V)	
Degree of Protection	IP40 (IEC60529)	
Weight (Approx.)	Display unit: 16g End plates: 4.5g (pair)	

Terminal Connection

	Connection Diagram	Terminal Arrangement	Internal Input Circuit
Decimal/Hexadecimal/Extra Decimal Display Units	<p><b>Standard</b></p>	<p><b>Standard</b></p>	<p><b>Positive Logic</b></p> <p><b>Negative Logic</b></p>
	<p><b>Zero-suppress</b></p>	<p><b>Zero-suppress</b></p>	

External Wiring

Decimal/Hexadecimal/Extra Decimal Display Units

Positive Logic

[Contact Input (Digital Switch)] [Transistor Input]

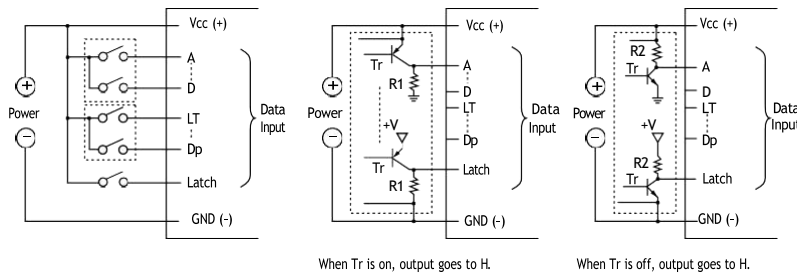

Negative Logic

[Contact Input (Digital Switch)] [Transistor Input]

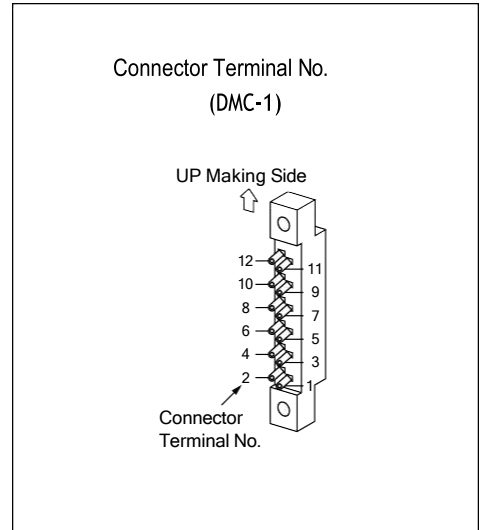
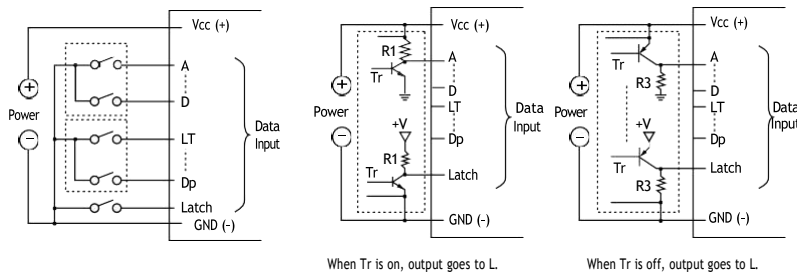

Note: When connecting pull-up or pull-down resistors to the external circuit, refer to the resistor values shown below:

- R1: 2.2 kΩ (1/2W) to 10 kΩ (1/4W)
- R2: 1 kΩ (1W) to 2.2 kΩ (1/2W)
- R3: 1 kΩ (1W)

Note: When the connected device has transistor output, use of products that have NPN output with negative logic or PNP output with positive logic are recommended.

## Function Table

### Decimal/Hexadecimal/Extra Decimal Display Units

(Standard and Zero-suppress)

Data Input														LED Display				
Positive Logic							Negative Logic							Dec.	Hex.	Extra Dec.		
D	C	B	A	Latch	LT	BL	DP	D	C	B	A	Latch	LT	BL	DP			
x	x	x	x	x	H	x	x	x	x	x	x	x	L	x	x	8.	8.	8.
x	x	x	x	x	L	H	x	x	x	x	x	x	H	L	x	blank	blank	blank
x	x	x	x	x	L	L	H	x	x	x	x	x	H	H	L	*	*	*
L	L	L	L	L	L	L	L	H	H	H	H	H	H	H	H	0	0	0
L	L	L	H	L	L	L	L	H	H	H	L	H	H	H	H	1	1	1
L	L	H	L	L	L	L	L	H	H	L	H	H	H	H	H	2	2	2
L	L	H	H	L	L	L	L	H	H	L	H	H	H	H	H	3	3	3
L	H	L	L	L	L	L	L	H	L	H	H	H	H	H	H	4	4	4
L	H	L	H	L	L	L	L	H	L	H	L	H	H	H	H	5	5	5
L	H	H	L	L	L	L	L	H	L	L	H	H	H	H	H	6	6	6
L	H	H	H	L	L	L	L	H	L	L	L	H	H	H	H	7	7	7
H	L	L	L	L	L	L	L	H	H	H	H	H	H	H	H	8	8	8
H	L	L	H	L	L	L	L	H	H	L	H	H	H	H	H	9	9	9
H	L	H	L	L	L	L	L	H	L	H	H	H	H	H	H	blank	A	-
H	L	H	H	L	L	L	L	H	L	L	H	H	H	H	H	blank	b	-
H	H	L	L	L	L	L	L	L	L	H	H	H	H	H	H	blank	C	-
H	H	L	H	L	L	L	L	L	L	H	L	H	H	H	H	blank	d	=
H	H	H	L	L	L	L	L	L	L	L	H	H	H	H	H	blank	E	=
H	H	H	H	L	L	L	L	L	L	L	L	H	H	H	H	blank	F	blank
x	x	x	x	H	L	L	L	x	x	x	x	L	H	H	H	maintain	maintain	maintain

Note 1: x indicates the display is not affected by voltage level of H or L.

Note 2: \* A decimal point is displayed with any character.

### Input Functions

A, B, C, and D (binary code) Inputs  
These inputs are decimal or data corresponding to 1, 2, 4, and 8, respectively.

#### Latch Input

When the Latch input is set to level H for the positive logic or level L for the negative logic, the display at the time is maintained. (DP input is independent.)

#### LT (Light Test) Input

When the LT input is set to level H for the positive logic or level L for the negative logic, the entire display turns on.

#### BL (Blank) Input

When the BL input is set to level H for the positive logic or level L for the negative logic, the entire display turns off regardless of other inputs.

#### DP (Decimal Point) Input

When the DP input is set to level H for the positive logic or level L for the negative logic, the decimal point turns on.

### (Zero-suppress Unit)

Leading zeros are suppressed using the RBI (No. 1) and RBO (No. 11) terminals. For other inputs, see the lower table on the preceding page.

Decimal/Hexadecimal/Extra Decimal																
Data Input											LED Display					
Positive Logic						Negative Logic										
X	Latch	LT	BL	DP	RBI	RBO	Y	Latch	LT	BL	DP	RBI	RBO			
x	x	H	x	x	x	#	x	x	L	x	x	x	⋄	8.		
x	x	L	H	x	x	#	x	x	H	L	x	x	⋄	blank		
H	L	L	L	L	L	L	H	H	H	H	H	L	L	blank		
H	L	L	L	L	H	H	H	H	H	H	H	H	H	0		
H	L	L	L	H	L	H	H	H	H	H	L	L	H	0.		
L	L	L	L	L	L	L	L	L	H	H	H	L	H	*		

X: X = A · B · C · D      \*: Any display

Y: Y = A · B · C · D      #: # = DP · RBI · X

x: Either H or L      ⋄: ⋄ = DP · RBI · Y

Note: RBI and RBO operate in the negative logic mode on both positive and negative logic units.

### Input and Output Functions

#### RBI Input

When 0 is displayed and the decimal point is turned off, the display is blanked by setting the RBI input to level L.

#### RBO Output

The RBO output remains in level L during zero blanking. Leading zeros can be suppressed by connecting the RBO to the RBI on the lower digits.

The RBO output is an open collector output.

### Application Examples of RBI and RBO

[Ex.1] Leading zeros are also displayed. RBI and RBO outputs are disconnected.

[Ex.2] Leading zeros on the upper three digits are suppressed. When the data on the 1st digit is zero, 0 is displayed.

[Ex.3] Zero on the 4th digit is suppressed. Zero and decimal point are displayed on the 3rd digit.

[Ex.4] Trailing zeros on the 2nd and 1st digits are suppressed. When the data on the 1st and 4th digits are zero, and the decimal point on the 4th digit is on, 0.0 is displayed with zeros on the 2nd and 1st digits suppressed.

Note: Use the RBO output only for connection to the RBI input. Do not use the RBO for other connections.

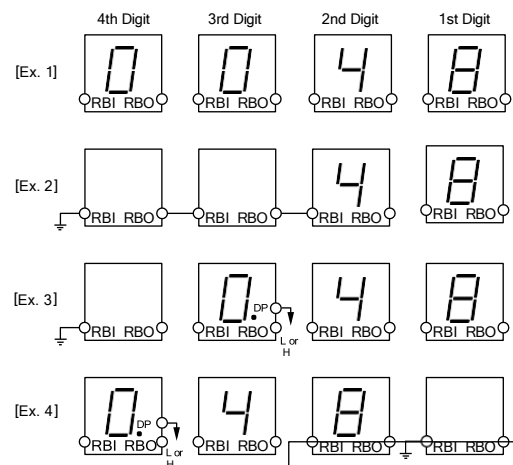

Dimensions & Panel Cut-out

All dimensions in mm.

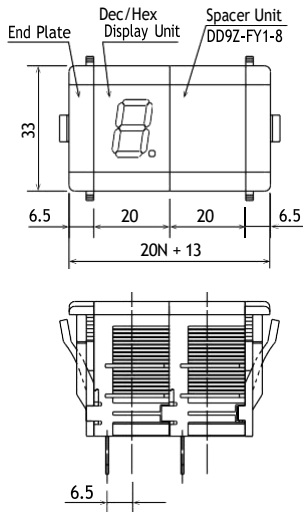

Display units can be combined for up to 8 digits.

Panel Cut-out For Connector Wiring For Use of Mother Board

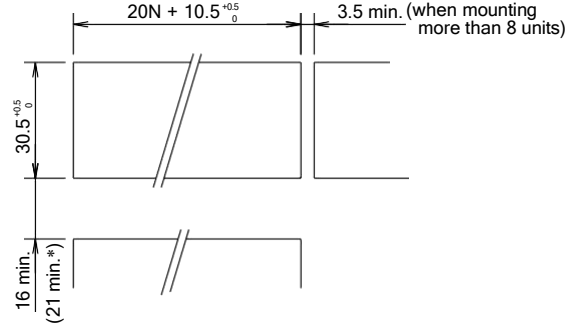

N = No. of digits (N ≤ 8)  
\* When using a static mother board

Accessories (Optional)

Connector

Solder Terminal Connector (DMC-1)

Applicable Wire: ø0.8mm maximum  
AWG #22 maximum

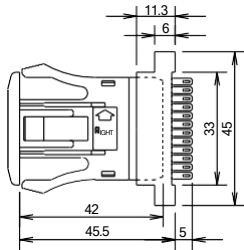

PC Board Terminal Connector (DMC-2)

Applicable PC board thickness: 1.6

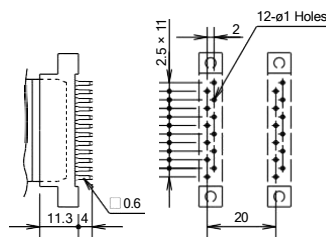

Retentive/One-way Insertion Connector (DD9Z-CN1)

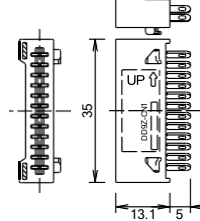

Connector Stopper (DD9Z-ST1)

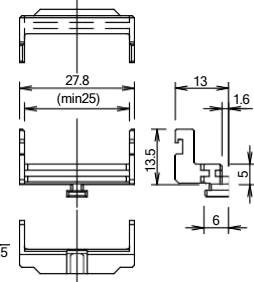

• Note: Use DD9Z-CN1 in combination with DD9Z-ST1 connector stopper.

Dynamic Mother Board (not applicable to zero-suppress)

4-digit: DD9Z-MB1-4  
2-digit: DD9Z-MB1-2

Substrate: Glass epoxy, 1.6-mm thick

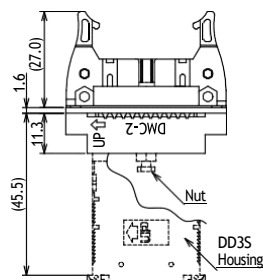
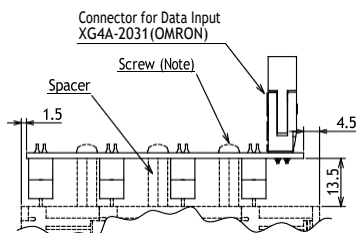

Note: The DD3S housing can be secured to the mother board using screws. Recommended tightening torque is 3.5 N·m at the maximum. When no spacer is used, the tightening torque must not exceed 2 N·m.

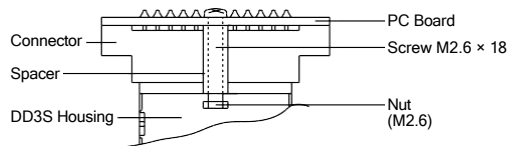

Screws (M2.6 × 18), M2.6-3 nuts, and spacers are supplied with the mother board.

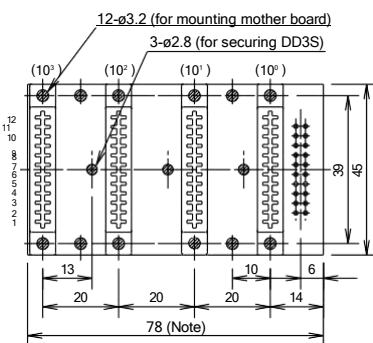

Note: 38 mm for 2-digit mother board DD9Z-MB1-2

Input Terminal Arrangement

For 4-digit (Top View)

GND	①	②	NC
A	③	④	B
C	⑤	⑥	D
LATCH (10°)	⑦	⑧	LATCH (10°)
LATCH (10°)	⑨	⑩	LATCH (10°)
BL (10°)	⑪	⑫	BL (10°)
BL (10°)	⑬	⑭	BL (10°)
LT	⑮	⑯	Dp (10°)
DP (10°)	⑰	⑱	Dp (10°)
DP (10°)	⑲	⑳	Vcc

For 2-digit (Top View)

GND	①	②	NC
A	③	④	B
C	⑤	⑥	D
LATCH (10°)	⑦	⑧	LATCH (10°)
NC	⑨	⑩	NC
BL (10°)	⑪	⑫	BL (10°)
NC	⑬	⑭	NC
LT	⑮	⑯	DP (10°)
DP (10°)	⑰	⑱	NC
NC	⑲	⑳	Vcc

Terminal Arrangement by Models

Standard	No.
F3**	
GND	12
NC	11
A	10
B	9
C	8
D	7
LATCH	6
BL	5
LT	4
C	3
Vcc	2
B	1
DP	
NC	

Static Mother Board (not applicable to zero-suppress)

- 4-digit: DD9Z-MB2-4
- 3-digit: DD9Z-MB2-3
- 2-digit: DD9Z-MB2-2

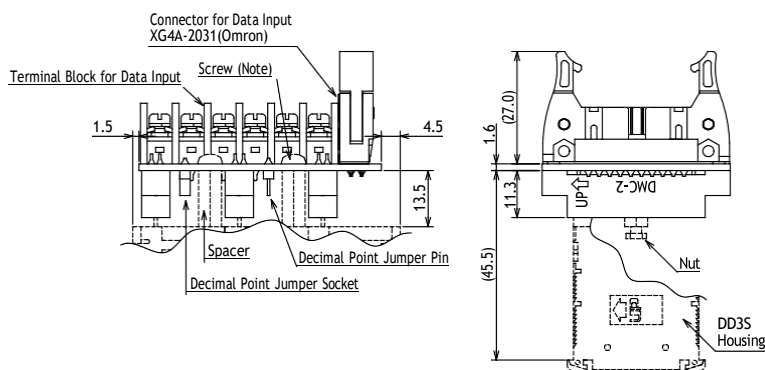

Note: The DD3S housing can be secured to the mother board using screws. Recommended tightening torque is 0.35 N·m at the maximum. When no spacer is used, the tightening torque must not exceed 0.2 N·m.

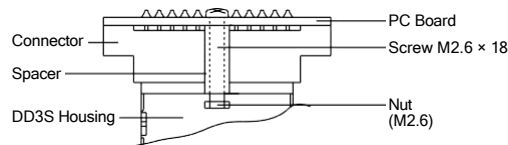

Screws (M2.6 × 18), M2.6 nuts, and spacers are supplied with the mother board.

4-digit

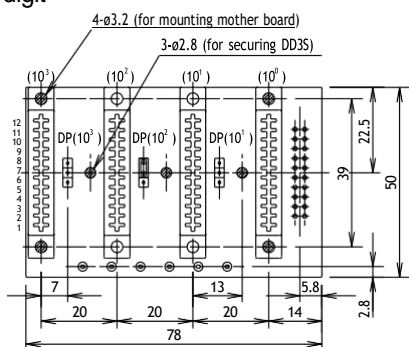

Input Terminal Arrangement

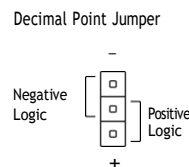
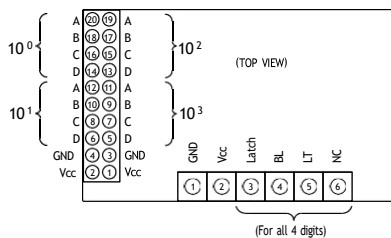

Terminal Arrangement by Models

Standard	No.
F3**	
GND	12
NC	11
A	10
D	9
LAT	8
BL	7
LT	6
C	5
Vcc	4
B	3
DP	2
NC	1

3-digit

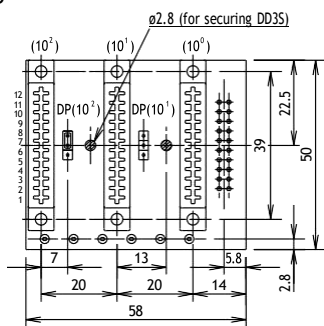

Input Terminal Arrangement

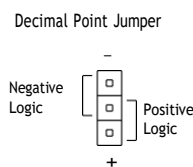
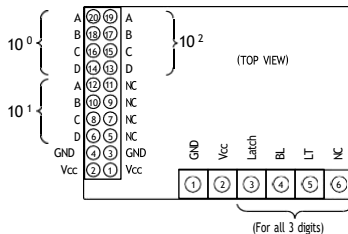

Terminal Arrangement by Models

Standard	No.
F3**	
GND	12
NC	11
A	10
D	9
LAT	8
BL	7
LT	6
C	5
Vcc	4
B	3
DP	2
NC	1

2-digit

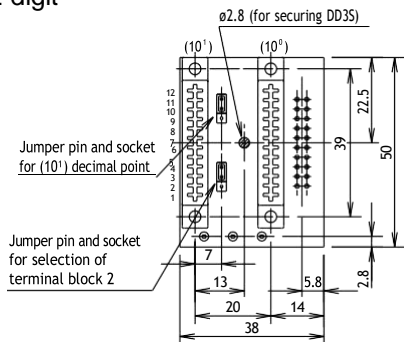

Input Terminal Arrangement

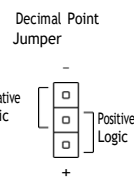
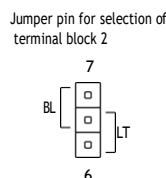
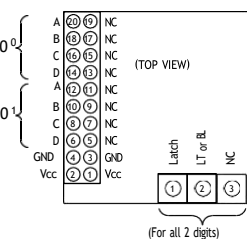

Terminal Arrangement by Models

Standard	No.
F3**	
GND	12
NC	11
A	10
D	9
LAT	8
BL	7
LT	6
C	5
Vcc	4
B	3
DP	2
NC	1

- A decimal point for the 2nd and the upper digits can be turned on using a jumper. Note positive and negative logic when using a jumper.
- For terminal No. 2 on terminal block used for 2-digit, select internal connection to terminal No. 6 or 7 on DD3S using a jumper.

## Wiring Diagrams

Static Mother Board Connection (2 to 4 digits)

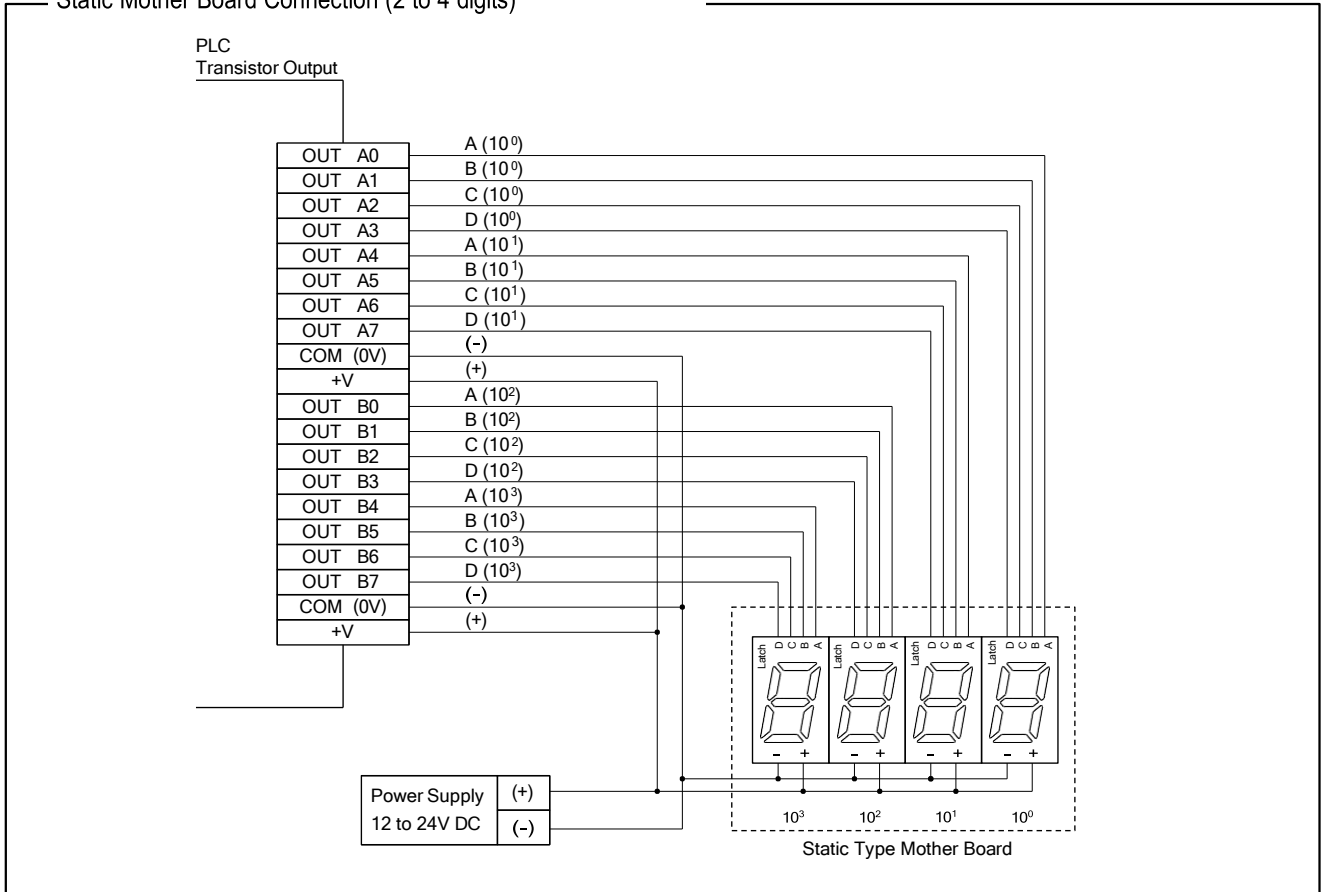

16-point Bus Connection (5 to 8 digits, multiple latch sets)

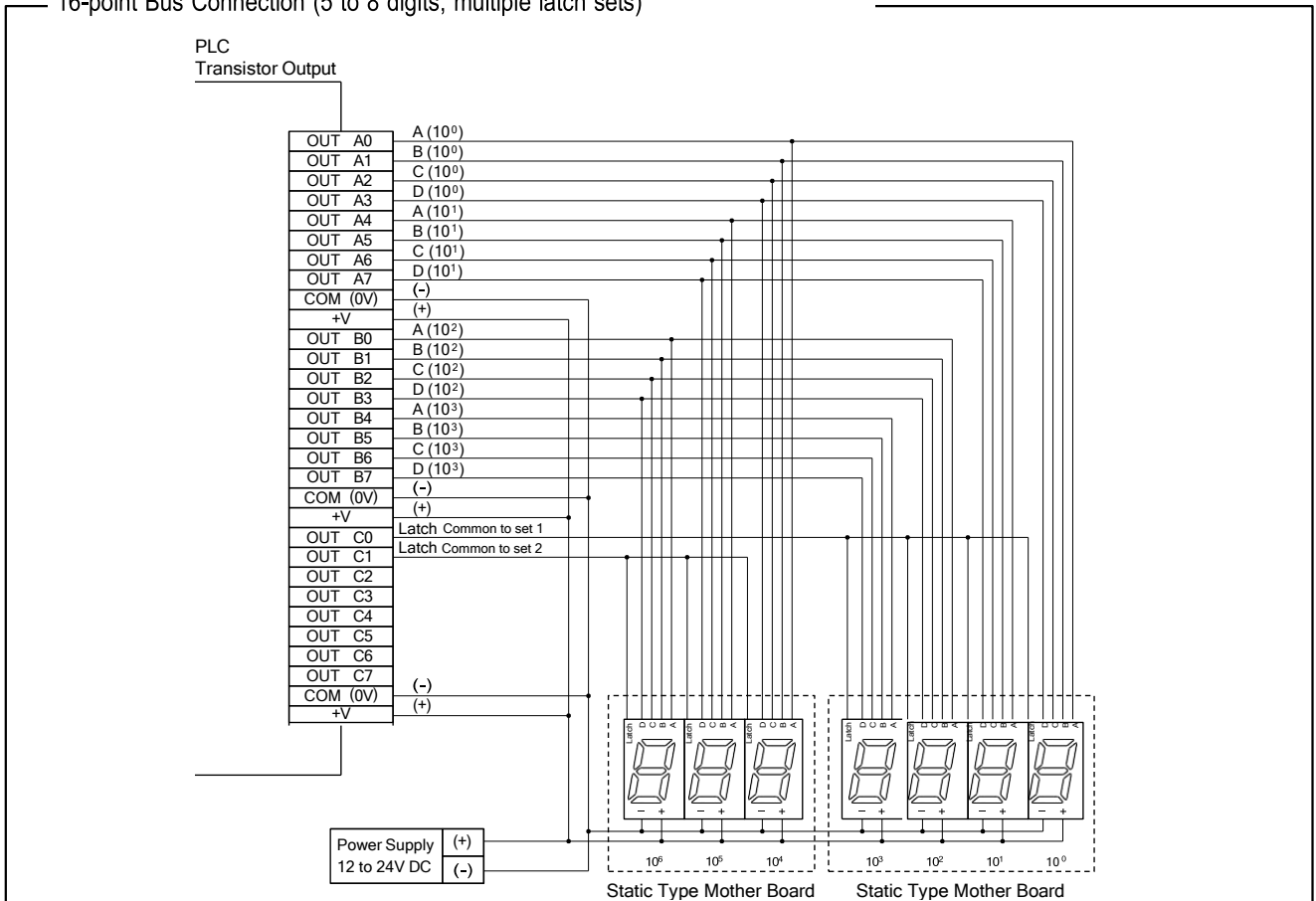

Dynamic Connection (2 to 4 digits)

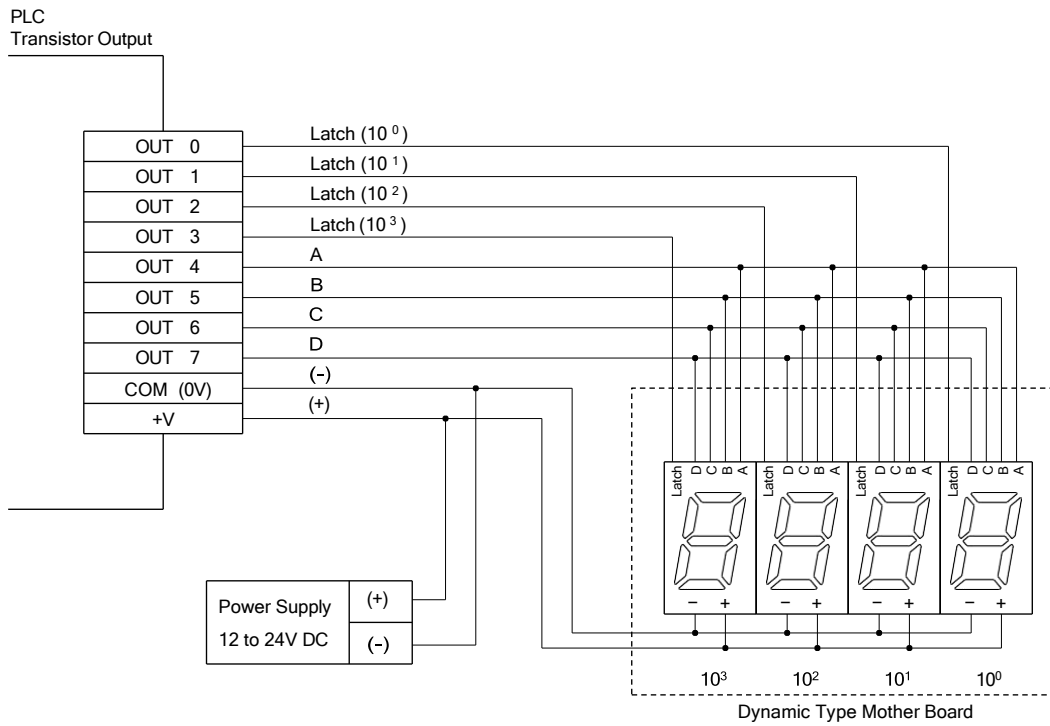

Dynamic Connection (5 to 8 digits)

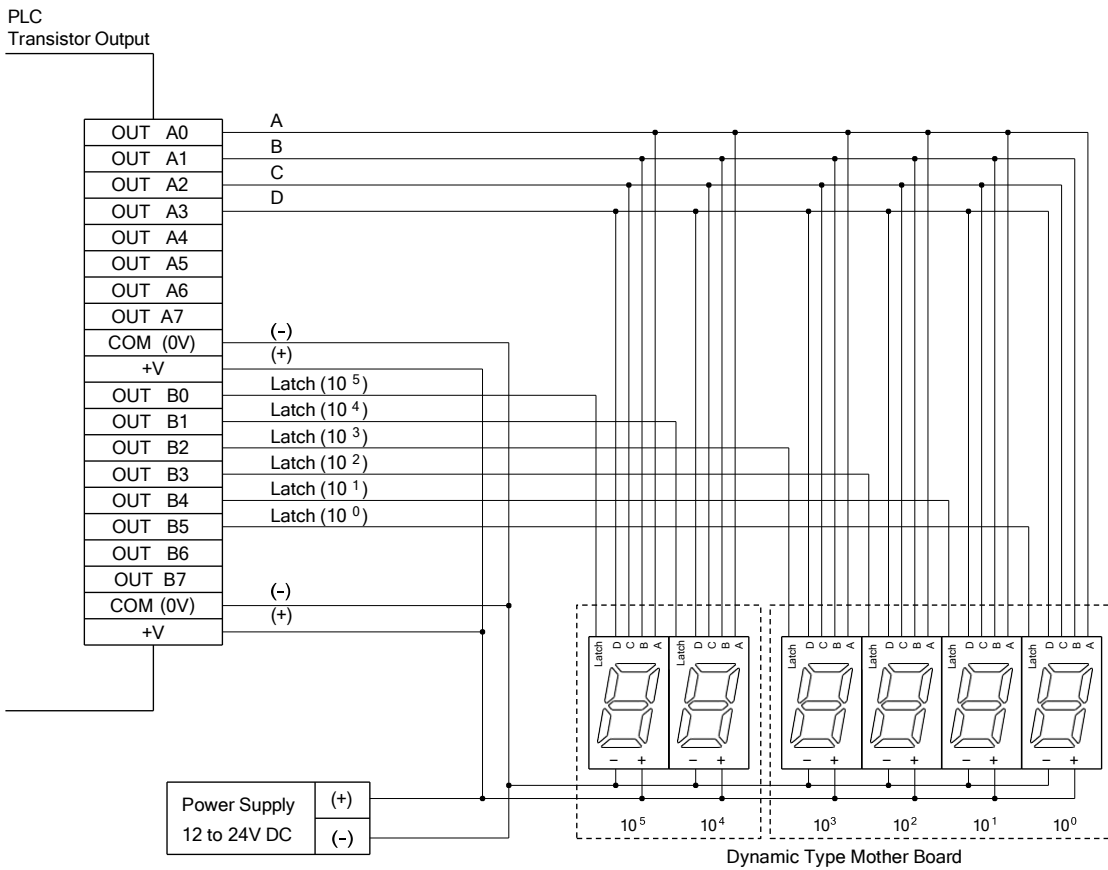

### Latch Input

[Binary/Decimal/Hex/Extra Decimal Display Units]

Latch Operation (Positive Logic)

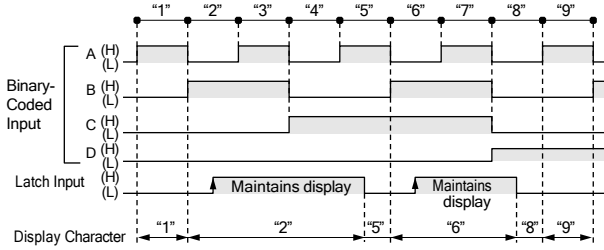

### Latch Input Timing Chart

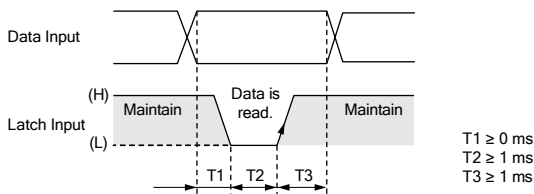

### Application of Latch Function

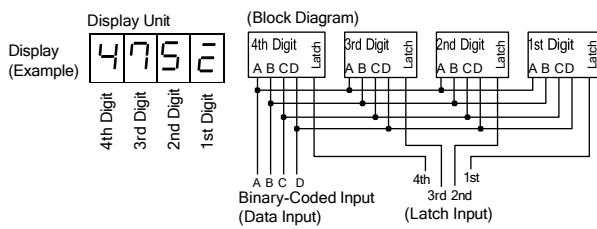
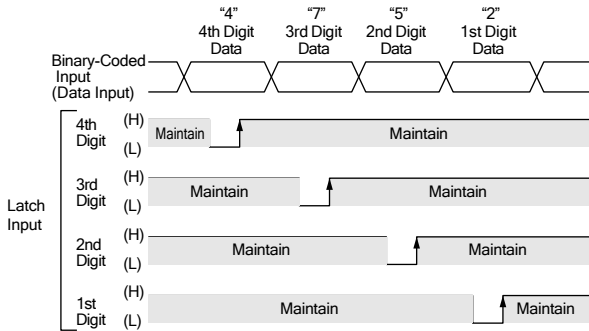

- Note 1: The above chart represents positive logic units. Negative logic units have characteristics with (H) and (L) reserved.
- Note 2: The rise and fall times of input pulses should be made as short as possible. (0.1 ms maximum)
- Note 3: If the data input is changed in the period of T2, the display will change.

### Unit Combination

Display units and end plates can be combined together by snap fit. Connection bolts and nuts are not required.

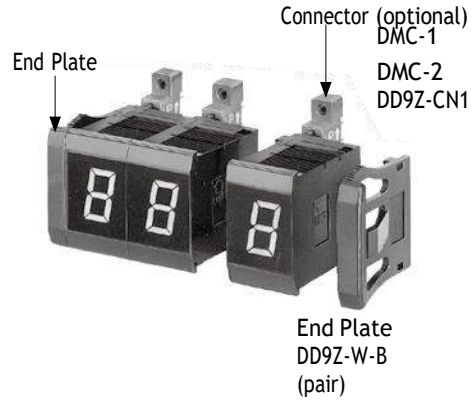

### Panel Mounting

Display units can be installed into a panel cut-out by snap fit. Assemble display units and end plates together in advance. Hold the assembly at the end plates and push it into a panel cut-out.



### Mother Board (for 4-digit display)

The mother board is intended for 4-digit display and must be connected to four display units at once. Therefore, mount or dismount the mother board properly according to the procedure below.

### [Installation]

Put the substrates of four display units into the connectors on the mother board. Insert the substrates into the connectors, pushing the display units on upper and lower sides alternately. Note: Be sure to insert four display units at once.

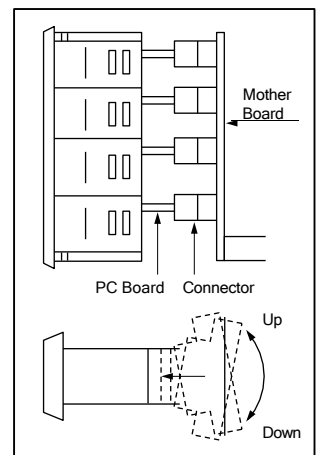

### [Removal]

Remove the display units, pulling the upper and lower sides alternately. Be sure to remove all the four units at the same time.

### CAUTION:

Never insert or remove the display units one by one as shown. The substrate may be damaged.

Note: For installation of the mother board for 2-digit and 3-digit display, perform the same procedure.

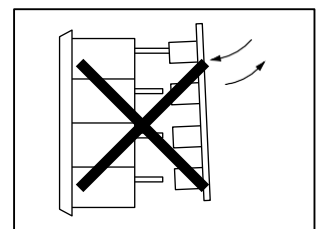

## Instructions

1. When cleaning the surface of the filter and housing, use a soft cloth. Do not use thinner or acid to clean the surface.
2. When the display unit is mounted in a panel cut-out, do not place a metal object or power line within 40 mm from the end of the connector terminals (or PC board terminals) at the rear of the display unit.
3. If the display units are subjected to voltage surges, install a surge suppressor in the power line.
4. Use shielded cable or metal conduit for the input line. Run the input wiring as far away as possible from high-voltage and motor lines. Make the input line as short as possible.
5. When using display units in environments where a large amount of electrostatic noise is generated, such as where molding materials, powders, or fluids are transferred through pipe lines, keep the display units as far away as possible from electrostatic sources.
6. Avoid using the display unit in a place where excessive and frequent vibration or impact may occur.
7. Avoid using the display unit in a place where it is exposed to corrosive gas, water or oil splashes, dust or direct sunlight, or in a place where organic solvents are used.
8. The filter is made of polycarbonate. Make sure that machine oil does not touch the filter.
9. If the Latch input is on when the DD3S is powered up, the data input cannot be read correctly or wrong data may be maintained. Do not turn on the Latch input for 0.5 sec after the DD3S is powered up.
10. When connecting a pull-up or pull-down resistor to the input terminals, ensure compatibility with the input resistor of the DD3S internal circuit.
11. When the DD3S is powered up, an inrush current of 0.3A (10 ms maximum) flows through the internal power supply circuit. Select an external power supply of sufficient capacity, taking this inrush current into consideration.
12. Solder the terminal at 350°C within 3 seconds using a 60W soldering iron. Sn-Ag-Cu is recommended when using lead-free solder. When soldering, do not touch the control unit with the soldering iron. Also ensure that no tensile force is applied to the terminal. Do not bend the terminal or apply excessive force to the terminal. Use a non-corrosive rosin flux.

# DD96 series Display Units

Two mounting styles; front and rear mount.  
High visible large LEDs;  
character height 57 mm.

- Modular units can be combined for up to 8-digits.
- Super bright LED
- Units can be combined together and installed into a panel cut-out by snap fit.
- Easy wiring and maintenance
- Display units operate on 24V DC.
- Jumbo size model of 96H × 72W mm (character height 57 mm), high visible from a distance.



## DD96

Item		Input Logic	Housing Color	Part No.
Front Mount	Decimal Display Unit	Negative	Black	DD96-F31N-B
	End Plate (pair)		Black	DD96-W-B
Rear Mount	Decimal Display Unit	Negative	Black	DD96-R31N-B

Note: A connector is supplied with each display unit.

## Specifications

Power Voltage	24V DC ±10%
Current Draw	Approx. 80 mA
Operating Temperature	-10 to +55°C (no freezing)
Storage Temperature	-25 to +80°C (no freezing)
Operating Humidity	35 to 85% RH (no condensation)
Data Input	L: 0 to 2V H: 12 to 30V
Display Character	7-segment red LED display Decimal display unit: 0 to 9, decimal point
Character Height	57 mm
Input	Binary-coded, Latch, DP and BI inputs
Input Logic	Negative
Output	BO (blanking output)
No. of Digits	8 digits max.
Panel Mounting	Front mount: Snap fit Rear mount: Screw
Degree of Protection	IP40 (IEC 60529)
Weight (Approx.)	Front mount: 130g End plates: 26g (pair) Rear mount: 100g

## Terminal Connection

### Connection Diagram

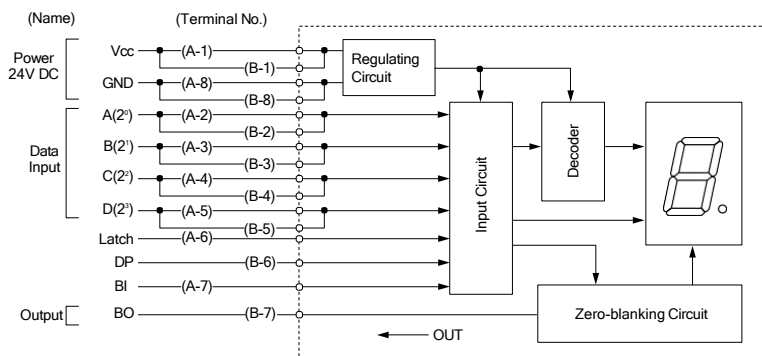

### Internal Input Circuit

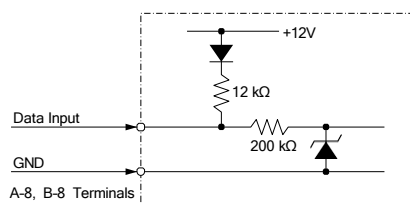

### Terminal Arrangement (Connector) Bottom View

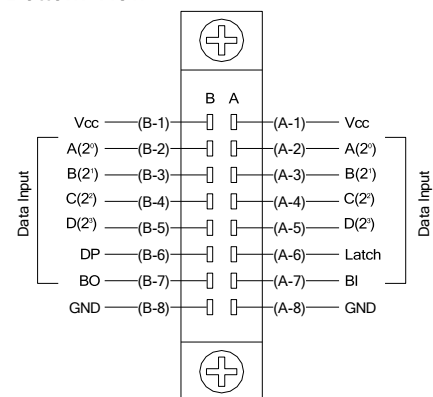

Note: Since power supply terminals and terminals A(2), B(2), C(2) and D(2) on sides A and B are internally connected to each other, connection is sufficient to only one side, but use terminals on the same side for jumper wiring.

Applicable Wire: Solid  $\phi 0.6$  maximum  
Stranded AWG28 to 30

### External Wiring

[Contact Input (Digital Switch)]

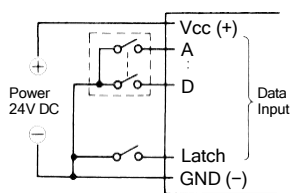

[Transistor Input]

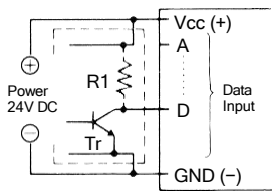

When Tr is on, output goes to L.

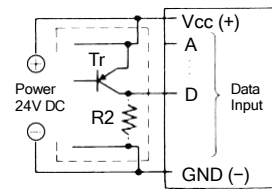

When Tr is off, output goes to L.

Note: When connecting a pull-up or pull-down resistor to the external circuit, R1 and R2 should be 2.2 to 10 kΩ (1/2 to 1/4W) and 1 to 2.2 kΩ (1 to 1/2W), respectively.

### Function Table

Data Input							LED Display	Output
Negative Logic Type							Decimal Display Unit	BO
D	C	B	A	DP	BI			
H	H	H	H	H	H	H	blank	H
H	H	H	H	H	H	L	0	L
H	H	H	L	H	H	Δ	1	L
H	H	L	H	H	H	Δ	2	L
H	H	L	L	H	H	Δ	3	L
H	L	H	H	H	H	Δ	4	L
H	L	H	L	H	H	Δ	5	L
H	L	L	H	H	H	Δ	6	L
H	L	L	L	H	H	Δ	7	L
L	H	H	H	H	H	Δ	8	L
L	H	H	L	H	H	Δ	9	L
L	H	L	H	H	H	Δ	blank	L
L	H	L	L	H	H	Δ	blank	L
L	L	H	H	H	H	Δ	blank	L
L	L	H	L	H	H	Δ	blank	L
L	L	L	H	H	H	Δ	blank	L
L	L	L	L	H	H	Δ	blank	L
x	x	x	x	L	H	Δ	maintain	

#### Input and Output Function

A, B, C, and D (binary code) Input

A, B, C and D are binary-coded decimal inputs corresponding to 1, 2, 4 or 8.

Latch Input

When the Latch input is set to level L, the display at the time is maintained. (DP and BI inputs are independent.)

DP (Decimal Point)

When the DP input is set to level L, the decimal point turns on.

BI (Zero Blanking Input)

When the BI input is set to level H with 0 displayed, the display is blanked.

BO (Blanking Output)

The BO output goes to level H during zero blanking. Leading zeros can be suppressed by connecting the BO to the BI on the lower digits.

Note:

x indicates the display after inputting the Latch signal is maintained regardless of the voltage level of H or L.

Δ indicates the display is not affected by voltage level of H or L.

DP (decimal point) turns on when the DP input signal is in level L.

### Dimensions & Panel Cut-out

#### Front Mount

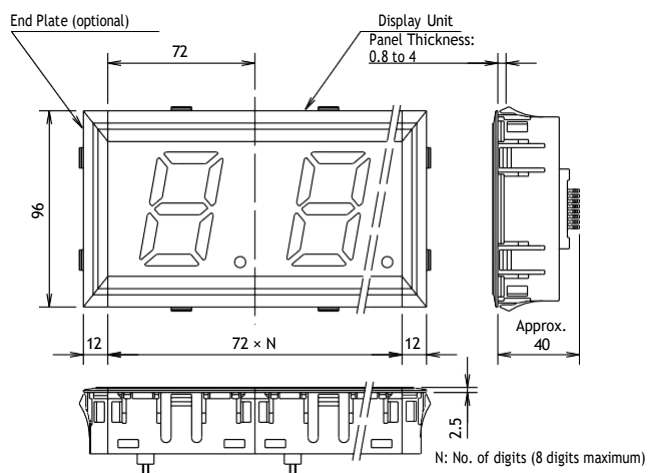

#### (Panel Cut-out)

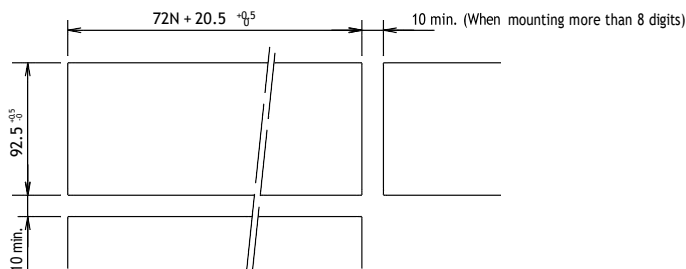

#### Rear Mount

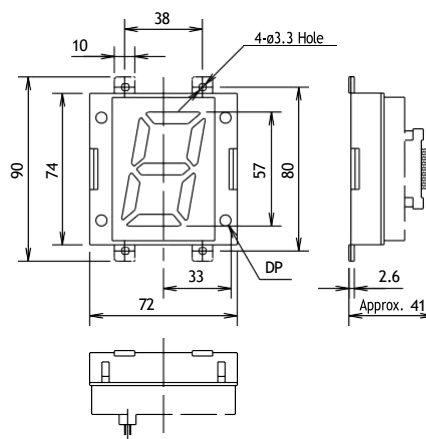

All dimensions in mm.

## Instructions

### Unit Combination

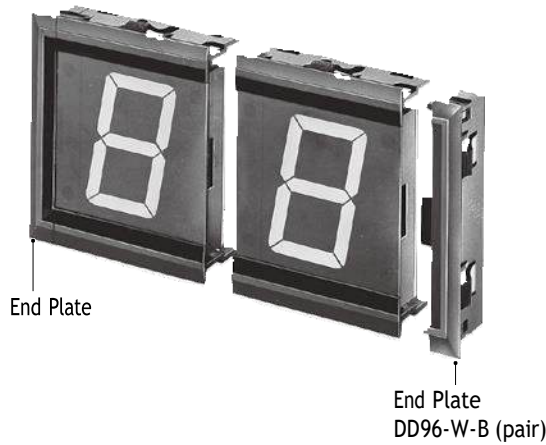

Only end plates snap onto DD96 display units; display units cannot be combined with each other by snap fit. DD96 rear mount units do not require end plate.

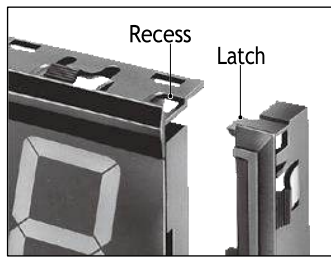

[Installing End Plates]  
Press the end plate onto the side of the display unit.

[Removing End Plates]  
Disengage the latches on top and bottom of the end plate using a screwdriver. Do not apply excessive force to the latches, or the latches may be damaged.

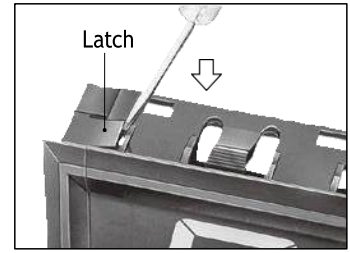

### Panel Mounting

Install end plates onto display units at both ends and install the units into panel cut-out, then install display units in the middle.

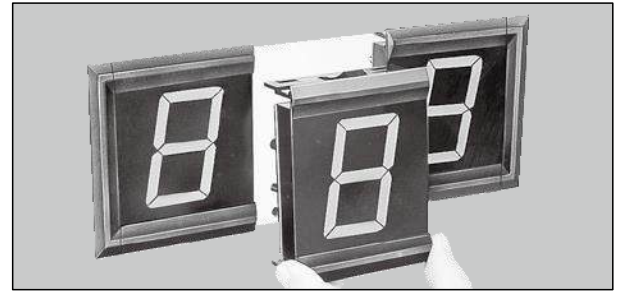

## Latch Input

### Latch Operation

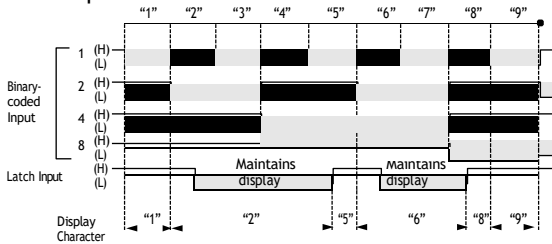

### Latch Input Timing Chart

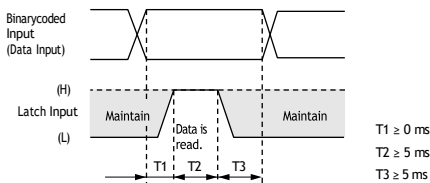

Note: If the data input is changed in the period of T2, the display will change.

### Application of Latch Function

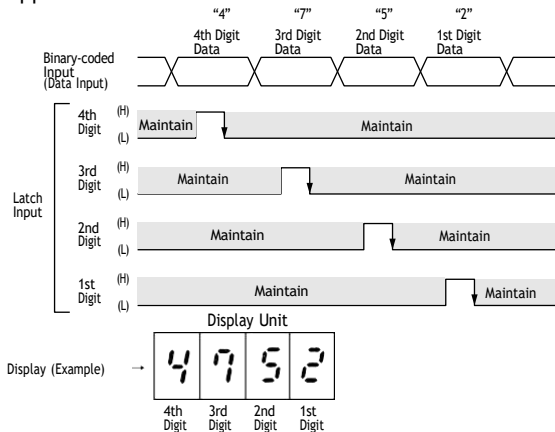

## Block Diagram

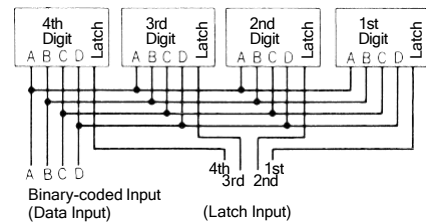

## Connection to Terminals BI and BO

[Ex. 1]

By connecting as shown below, 0 is displayed when input is 0000 and 25 is displayed when input is 0025, eliminating unnecessary 0s in upper digits.

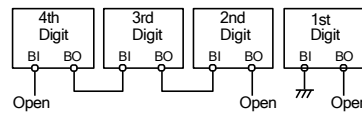

[Ex. 2]

By connecting as shown below, 0000 is displayed when input is 0000 and 0025 is displayed when input is 0025, with all 0s in upper digits displayed.

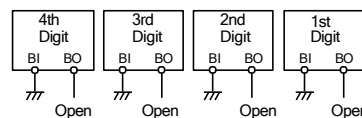

Notes:

1. Use BO output only for connection to BI input in the lower digit as shown in Ex. 1 above. Do not use the BO for other purposes.
2. When zero blanking is not required, maintain BI input in level L.

## Instructions

1. A red filter is not provided for the front of the DD96 series rear mount display unit.
2. When cleaning the surface of the filter and housing, use a soft cloth. Do not use thinner or acid to clean the surface
3. When the display unit is mounted in a panel cut-out, do not place a metal object or power line within 40 mm from the end of the connector terminals at the rear of the display unit.
4. If the display unit is subjected to voltage surges, install a surge suppressor in the power line.
5. Use shielded cable or metal conduit for the input line. Run the input wiring as far away as possible from high-voltage and motor lines. Make the input line as short as possible.
6. When using display units in environments where a large amount of electrostatic noise is generated, such as where molding materials, powders, or fluids are transferred through pipe lines, keep the display units as far away as possible from electrostatic sources.
7. Avoid using the display unit in a place where excessive and frequent vibration or impact may occur.
8. Avoid using the display unit in a place where it is exposed to corrosive gas, water or oil splashes, dust or direct sunlight, or in a place where organic solvents are used.
9. The filter is made of polycarbonate. Make sure that machine oil does not touch the filter.
10. If the Latch input is on when the DD96 is powered up, the data input cannot be read correctly or wrong data may be maintained. Do not turn on the Latch input for 0.5 sec after the DD96 is powered up.
11. When the DD96 is powered up, an inrush current of 0.4A (10 ms maximum) flows through the internal power supply circuit. Select an external power supply of sufficient capacity, taking inrush current into consideration.
12. When connecting a pull-up or pull-down resistor to the input terminals, ensure compatibility with the input resistor in the DD96 internal circuit.

# Ordering Terms and Conditions

Thank you for using IDEC Products

By purchasing products listed in our catalogs, datasheets, and the like (hereinafter referred to as "Catalogs") you agree to be bound by these terms and conditions. Please read and agree to the terms and conditions before placing your order.

## 1. Notes on contents of Catalogs

- (1) Rated values, performance values, and specification values of IDEC products listed in this Catalog are values acquired under respective conditions in independent testing, and do not guarantee values gained in combined conditions.  
Also, durability varies depending on the usage environment and usage conditions.
- (2) Reference data and reference values listed in Catalogs are for reference purposes only, and do not guarantee that the product will always operate appropriately in that range.
- (3) The specifications / appearance and accessories of IDEC products listed in Catalogs are subject to change or termination of sales without notice, for improvement or other reasons.
- (4) The content of Catalogs is subject to change without notice.

## 2. Note on applications

- (1) If using IDEC products in combination with other products, confirm the applicable laws / regulations and standards.  
Also, confirm that IDEC products are compatible with your systems, machines, devices, and the like by using under the actual conditions. IDEC shall bear no liability whatsoever regarding the compatibility with IDEC products.
- (2) The usage examples and application examples listed in Catalogs are for reference purposes only. Therefore, when introducing a product, confirm the performance and safety of the instruments, devices, and the like before use. Furthermore, regarding these examples, IDEC does not grant license to use IDEC products to you, and IDEC offers no warranties regarding the ownership of intellectual property rights or non-infringement upon the intellectual property rights of third parties.
- (3) When using IDEC products, be cautious when implementing the following.
  - i. Use of IDEC products with sufficient allowance for rating and performance
  - ii. Safety design, including redundant design and malfunction prevention design that prevents other danger and damage even in the event that an IDEC product fails
  - iii. Wiring and installation that ensures the IDEC product used in your system, machine, device, or the like can perform and function according to its specifications
- (4) Continuing to use an IDEC product even after the performance has deteriorated can result in abnormal heat, smoke, fires, and the like due to insulation deterioration or the like. Perform periodic maintenance for IDEC products and the systems, machines, devices, and the like in which they are used.
- (5) IDEC products are developed and manufactured as general-purpose products for general industrial products. They are not intended for use in the following applications, and in the event that you use an IDEC product for these applications, unless otherwise agreed upon between you and IDEC, IDEC shall provide no guarantees whatsoever regarding IDEC products.
  - i. Use in applications that require a high degree of safety, including nuclear power control equipment, transportation equipment (railroads / airplanes / ships / vehicles / vehicle instruments, etc.), equipment for use in outer space, elevating equipment, medical instruments, safety devices, or any other equipment, instruments, or the like that could endanger life or human health
  - ii. Use in applications that require a high degree of reliability, such as provision systems for gas / waterworks / electricity, etc., systems that operate continuously for 24 hours, and settlement systems
  - iii. Use in applications where the product may be handled or used deviating from the specifications or conditions / environment listed in the Catalogs, such as equipment used outdoors or applications in environments subject to chemical pollution or electromagnetic interference  
If you would like to use IDEC products in the above applications, be sure to consult with an IDEC sales representative.

## 3. Inspections

We ask that you implement inspections for IDEC products you purchase without delay, as well as thoroughly keep in mind management/maintenance regarding handling of the product before and during the inspection.

## 4. Warranty

### (1) Warranty period

The warranty period for IDEC products shall be one (1) year after purchase or delivery to the specified location. However, this shall not apply in cases where there is a different specification in the Catalogs or there is another agreement in place between you and IDEC.

### (2) Warranty scope

Should a failure occur in an IDEC product during the above warranty period for reasons attributable to IDEC, then IDEC shall replace or repair that product, free of charge, at the purchase location / delivery location of the product, or an IDEC service base. However, failures caused by the following reasons shall be deemed outside the scope of this warranty.

- i. The product was handled or used deviating from the conditions / environment listed in the Catalogs
- ii. The failure was caused by reasons other than an IDEC product
- iii. Modification or repair was performed by a party other than IDEC
- iv. The failure was caused by a software program of a party other than IDEC
- v. The product was used outside of its original purpose
- vi. Replacement of maintenance parts, installation of accessories, or the like was not performed properly in accordance with the user's manual and Catalogs
- vii. The failure could not have been predicted with the scientific and technical standards at the time when the product was shipped from IDEC
- viii. The failure was due to other causes not attributable to IDEC (including cases of force majeure such as natural disasters and other disasters)

Furthermore, the warranty described here refers to a warranty on the IDEC product as a unit, and damages induced by the failure of an IDEC product are excluded from this warranty.

## 5. Limitation of liability

The warranty listed in this Agreement is the full and complete warranty for IDEC products, and IDEC shall bear no liability whatsoever regarding special damages, indirect damages, incidental damages, or passive damages that occurred due to an IDEC product.

## 6. Service scope

The prices of IDEC products do not include the cost of services, such as dispatching technicians. Therefore, separate fees are required in the following cases.

- (1) Instructions for installation / adjustment and accompaniment at test operation (including creating application software and testing operation, etc.)
- (2) Maintenance inspections, adjustments, and repairs
- (3) Technical instructions and technical training
- (4) Product tests or inspections specified by you

The above content assumes transactions and usage within your region. Please consult with an IDEC sales representative regarding transactions and usage outside of your region. Also, IDEC provides no guarantees whatsoever regarding IDEC products sold outside your region.

# IDEC CORPORATION

Head Office 6-64, Nishi-Miyahara-2-Chome, Yodogawa-ku, Osaka 532-0004, Japan

**USA** IDEC Corporation  
**EMEA** APEM SAS

**Singapore** IDEC Izumi Asia Pte. Ltd.  
**Thailand** IDEC Asia (Thailand) Co., Ltd.  
**India** IDEC Controls India Private Ltd.

**China** IDEC (Shanghai) Corporation  
IDEC Izumi (H.K.) Co., Ltd.  
**Taiwan** IDEC Taiwan Corporation

**Japan** IDEC Corporation

 [www.idec.com](http://www.idec.com)

Specifications and other descriptions in this brochure are subject to change without notice.

2024 IDEC Corporation, All Rights Reserved.

