

# HE2B Double Three-position Enabling Switches

Multi-contact 3-position enabling switches Ideal for installing in large teach pendants



• See website for details on approvals and standards.

## HE2B

Shape	Style	Contact Configuration			Part No.	Ordering No.	Package Quantity
		3-position Switch	Return Monitor Switch	Depress Monitor Switch			
	With Rubber Boot Rubber Boot Material: Silicon Rubber Color: B: black Y: yellow	2	0	0	HE2B-M200P*	HE2B-M200P*	1
		2	1	1	HE2B-M211P*	HE2B-M211P* HE2B-M211P*PN10	1 10
		2	2	2	HE2B-M222P*	HE2B-M222P* HE2B-M222P*PN10	1 10
	Rubber Boot Material: NBR/PVC Polyblend Color: gray	2	0	0	HE2B-M200PN1	HE2B-M200PN1 HE2B-M200PN1PN10	1 10
		2	1	1	HE2B-M211PN1	HE2B-M211PN1 HE2B-M211PN1PN10	1 10
		2	2	2	HE2B-M222PN1	HE2B-M222PN1 HE2B-M222PN1PN10	1 10

Note: Specify a rubber boot color code in place of \* in the Ordering No.

### Part No. Development

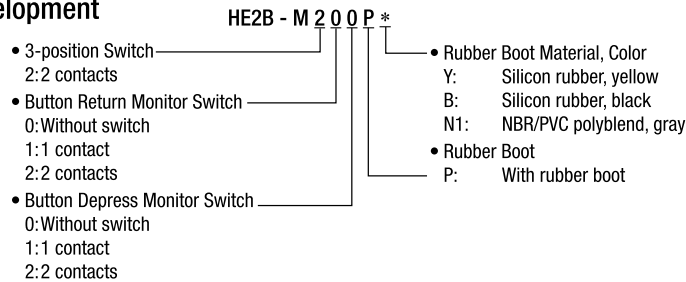

### Ratings

#### Contact Ratings

Rated Insulation Voltage (Ui)		250V				
Rated Thermal Current (Ith)		3A				
Rated Voltage (Ue)		30V	125V	250V		
Rated Current (Ie)	3-position Switch	AC	Resistive Load (AC-12)	—	1A	0.5A
			Inductive Load (AC-15)	—	0.7A	0.5A
		DC	Resistive Load (DC-12)	1A	0.2A	—
	Button Return Monitor Switch Button Depress Monitor Switch	AC	Resistive Load (AC-12)	—	2.5A	1.5A
			Inductive Load (AC-15)	—	1.5A	0.75A
		DC	Resistive Load (DC-12)	2.5A	1.1A	0.55A
Contact Configuration		3-position Switch	2 contacts			
		Return Monitor Switch	0 to 2 contacts			
		Depress Monitor Switch	0 to 2 contacts			

• Minimum applicable load (reference value): 3V AC/DC, 5 mA (monitor switch), 5V AC/DC, 1 mA (3-position switch)  
(Applicable range is subject to the operation conditions and load.)

APEM

Switches & Pilot Lights

Control Boxes

Emergency Stop Switches

Enabling Switches

Safety Products

Explosion Proof

Terminal Blocks

Relays & Sockets

Circuit Protectors

Power Supplies

LED Illumination

Controllers

Operator Interfaces

Sensors

AUTO-ID

HE2B

HE3B

HE5B

HE6B

HE2G

HE1G-L

Actuator w/  
Plastic Holder

# HE2B Double Three-position Enabling Switches

## Specifications

Applicable Standards	IEC/EN60947-5-8 (TUV approval), IEC/EN60947-5-1 UL508 (UL recognized), CSA C22.2 No. 14 (c-UL recognized), GB/T14048.5 (CCC approval)
Applicable Standards for Use	ISO12100-1, -2/EN12100-1, -2, IEC60204-1/EN60204-1, ISO11161/prEN11161 ISO10218/EN775, ANSI/RIA R15.06, ANSI B11.19
Operating Temperature	-25 to +60°C (no freezing) (without rubber boot, with silicon rubber boot) -10 to +60°C (no freezing) (with NBR/PVC polyblend rubber boot)
Relative Humidity	45 to 85% RH (no condensation)
Storage Temperature	-40 to +80°C (no freezing)
Pollution Degree	2 (inside panel, terminal side) 3 (outside panel, operator side)
Contact Resistance	50 mΩ maximum (initial value)
Insulation Resistance	Between live and dead metal parts: 100 MΩ minimum (500V DC megger) Between terminals of different poles: 100 MΩ minimum (500V DC megger)
Impulse Withstand Voltage	2.5 kV
Operating Frequency	1,200 operations per hour
Mechanical Durability	Position 1 → 2 → 1: 1,000,000 operations minimum Position 1 → 2 → 3 → 1: 100,000 operations minimum
Electrical Durability	100,000 operations minimum
Shock Resistance	Operating extremes: 150 m/s <sup>2</sup> Damage limits: 1,000 m/s <sup>2</sup>
Vibration Resistance	Operating extremes: 5 to 55 Hz, amplitude 0.5 mm Damage limits: 16.7 Hz, amplitude 1.5 mm
Terminal Style	Solder terminal
Applicable Wire	1 cable, 0.5 mm <sup>2</sup> maximum
Terminal Soldering Heat Resistance	310 to 350 °C, 3 seconds maximum
Terminal Tensile Strength	20N minimum
Mounting Screw Recommended Tightening Torque	0.5 to 0.8 N·m
Degree of Protection	IP40 (without rubber boot) IP65 (with rubber boot) (IEC 60529)
Conditional Short-circuit Current	50A (250V) (Use 250V/10A fast-blow fuse for short-circuit protection.)
Direct Opening Force	60N minimum (monitor switch)
Direct Opening Action Stroke	1.7mm minimum (return monitor switch), 4.7mm minimum (depress monitor switch)
Operator Strength	500N minimum (when pressing the entire button surface)
Weight (approx.)	26g (without rubber boot) 30g (with rubber boot)

## Operation Characteristics

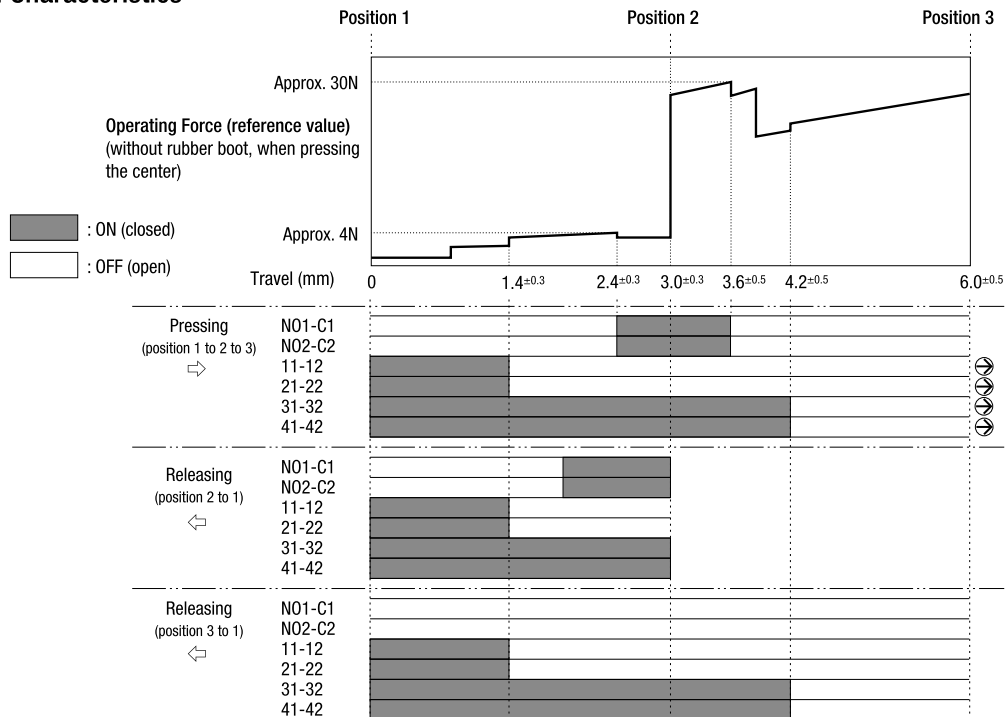

**Notes:**

- When a rubber boot is used, the operating force depends on the operating temperature.
- The operating force to shift the switch from position 2 to position 3 can be changed. For details, contact IDEC.

## Terminal Arrangement (Bottom View)

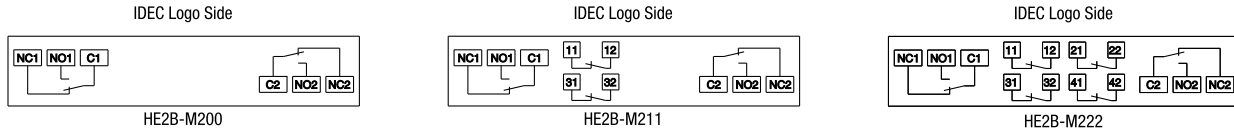

- 3-position switch (note): 2 contacts, terminal nos. between NO1 – C1, NO2 – C2
  - Button return monitor switch: 0 to 2 contacts, terminal nos. between 11 – 12, 21 – 22
  - Button depress monitor switch: 0 to 2 contacts, terminal nos. between 31 – 32, 41 – 42
- Note: Use NO and C terminals for OFF → ON → OFF 3-position switch (NC terminal is not used).

## Dimensions

### Without Rubber Boot

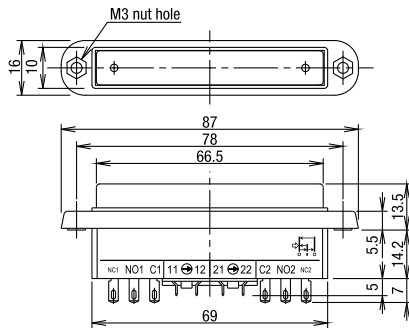

- M3 nuts are supplied with the HE2B enabling switch.

### With Rubber Boot

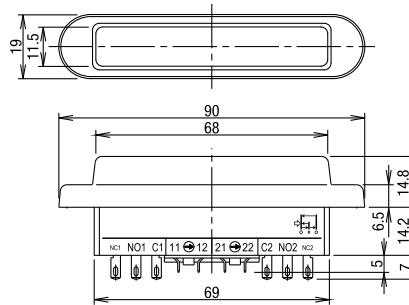

- M3 nuts are installed in the rubber boot.

## Mounting Hole Layout

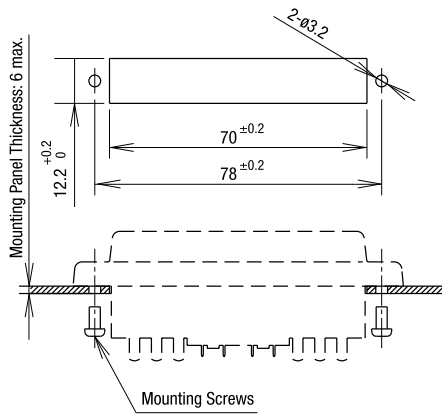

- Mounting screw: Two M3 screws
- Length of mounting screw: Mounting panel thickness + 4 to 5 mm

All dimensions in mm.

## Accessories

### Replacement Rubber Boot

Material	Color	Part No.	Ordering No.	Package Quantity
Silicon Rubber	Y: yellow	HE9Z-D2*	HE9Z-D2*PN10	10
	B: black			
NBR/PVC Polyblend	Gray	HE9Z-D2N1	HE9Z-D2N1PN10	

Note: Specify a rubber boot color code in place of \* in the Ordering No.

- Can be installed on HE2B (without rubber boot)



APEM

Switches & Pilot Lights

Control Boxes

Emergency Stop Switches

Enabling Switches

Safety Products

Explosion Proof

Terminal Blocks

Relays & Sockets

Circuit Protectors

Power Supplies

LED Illumination

Controllers

Operator Interfaces

Sensors

AUTO-ID

HE2B

HE3B

HE5B

HE6B

HE2G

HE1G-L

Actuator w/  
Plastic Holder

## HE2B Double Three-position Enabling Switches

### ⚠ Safety Precautions

- The enabling switches have been designed for industrial purposes. Use for residential, commercial, or lighting purposes may cause unwanted electromagnetic disturbances in which case the user may be required to take adequate mitigation measures. (IEC60947-1, Clause 5.3)
- In order to avoid electric shock or fire, turn the power off before installation, removal, wiring, maintenance, or inspection of the enabling switch.
- Do not assemble or modify the enabling switches and do not disable the enabling function. Otherwise, failure of accidents may occur.
- When using the enabling switch in a safety related part of a control system, use the enabling switch properly in accordance with the safety standards and regulations of the actual machine, system, and application, of the country or region where the enabling switch is used. Also, perform a risk assessment before using the enabling switch.
- Do not disable the safety function of the enabling switch by using tape, elastic band, or by disfiguring the rubber boot, otherwise the loss of enabling switch function may cause serious accidents.
- Perform a risk assessment in actual applications as strong force may be applied to the switch when depressed to position 3.
- Perform a risk assessment for the shape and structure of the part where the enabling switch is installed, to prevent unintended operation of the enabling switch. For example, an enabling switch protruding from the teach pendant may result in an unintended operation of the enabling switch.
- Strong force may be applied to a 3-position enabling switch when pressed to position 3. Provide sufficient strength to the part where 3-position enabling switches will be installed.
- Use wires of the proper size to meet voltage and current requirements, and solder the wires correctly according to the wiring instruction described below. If soldering is incomplete, the wire may heat during operation, causing a fire hazard.
- Do not apply excessive force to the enabling switch.
- Follow the wiring instructions mentioned in the instruction manual.

### Instructions

#### Operating Instructions

- The enabling switch permits machine operation only while the enabling switch is manually operated for robot teaching or other purposes in hazardous areas. Make sure that the control system is designed to activate the machine only when the enabling switch is at position 2 (3mm) operating travel.
- To achieve a high level of safety, connect the two contacts of the 3-position switch to a disparity detection circuit (e.g., safety relay module) (ISO 13849-1).
- Because two contacts are designed to operate independently, pressing the edge of a button turns on one contact earlier than the other contact, causing a delay in operation. To avoid this, always press the center of the button.
- The ridge on the bottom of rubber boot serves as a seal, and waterproof characteristics are attained when the ridge is tightly pressed to the mounting panel. When the mounting panel is bent and the ridge cannot be pressed to the panel, add a reinforcing rib to secure the boot to the mounting panel.
- The edge of rubber boot may stick out if excessive force is applied on the rubber boot. When such event is anticipated, it is recommended to embed the rubber boot in the mounting panel as shown in the figure below.

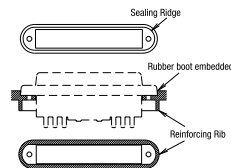

- Using enabling switches without rubber boots in an environment where foreign particles or dust exist may lead to malfunction. Order an optional rubber boot or add extra protection.
- The rubber boot may deteriorate depending on the operating environment and conditions. When the rubber boot is deformed or cracked, replace with new ones.

#### Installation Instructions

- Provide sufficient strength to the mounting panel. Insufficient strength of the mounting panel or excessive operating force may damage the enabling switch, resulting in electric shock or fire.

#### Wiring Instructions

- Applicable wire size: 0.5 mm<sup>2</sup> maximum × 1 pc.
- Solder the terminal at a temperature of 310 to 350°C within 3 seconds using a soldering iron. Sn-Ag-Cu type is recommended when using lead-free solder. Do not use flow or dip soldering.
- When soldering, take care not to touch the enabling switch with the soldering iron. Also ensure that no tensile force is applied to the terminal. Do not bend the terminal or apply excessive force to the terminal.
- Use non-corrosive liquid rosin as soldering flux.

APEM
Switches & Pilot Lights
Control Boxes
Emergency Stop Switches
Enabling Switches
Safety Products
Explosion Proof
Terminal Blocks
Relays & Sockets
Circuit Protectors
Power Supplies
LED Illumination

Controllers
Operator Interfaces
Sensors
AUTO-ID

HE2B
HE3B
HE5B
HE6B
HE2G
HE1G-L
Actuator w/ Plastic Holder

# HE3B ø16mm Rectangular Three-position Enabling Switches

Rectangular operator part with ø16 mm mounting for easy installation.  
2-contact 3-position enabling switches ideal for installing in small teach pendants.



• See website for details on approvals and standards.

## HE3B

Shape	Style	Contact Configuration	Part No.	Ordering No.	Package Quantity
	With Rubber Boot Rubber Boot Material: Silicon Rubber Color: Y: yellow, B: black	2 contacts (3-position switch)	HE3B-M2P*	HE3B-M2P*	1
				HE3B-M2P*PN10	10
	With Rubber Boot Rubber Boot Material: NBR/PVC Polyblend Color: gray		HE3B-M2PN1	HE3B-M2PN1	1
				HE3B-M2PN1PN10	10

Note: Specify a rubber boot color code in place of \* in the Ordering No.

## Contact Ratings

Rated Insulation Voltage (Ui)		125V	
Rated Thermal Current (Ith)		3A	
Rated Voltage (Ue)		30V	125V
Rated Current (Ie)	AC	Resistive Load (AC-12)	1A
		Inductive Load (AC-15)	0.7A
	DC	Resistive Load (DC-12)	0.2A
		Inductive Load (DC-13)	0.1A
Contact Configuration (3-position switch)		2 contacts	

Minimum applicable load (reference value): 5V AC/DC, 1 mA  
(Applicable range is subject to the operating conditions and load.)

## Specifications

Applicable Standards	IEC/EN60947-5-8 (TUV approval), IEC/EN60947-5-1, JIS C8201-5-1 UL508 (UL recognized), CSA C22.2 No. 14 (c-UL recognized), GB/T14048.5 (CCC approval)
Applicable Standards for Use	ISO12100-1, -2/EN12100-1, -2, IEC60204-1/EN60204-1 ISO11161/prEN11161, ISO10218/EN775, ANSI/RIA R15.06, ANSI B11.19, ISO13849-1 / EN ISO13849-1
Operating Temperature	-25 to +60°C (no freezing) (without rubber boot, with silicon rubber boot) -10 to +60°C (no freezing) (with NBR/PVC polyblend rubber boot)
Relative Humidity	45 to 85% (no condensation)
Storage Temperature	-40 to +80°C (no freezing)
Pollution Degree	2 (inside panel, terminal side) 3 (outside panel, operator side)
Contact Resistance	50 mΩ maximum (initial value)
Insulation Resistance	Between live and dead metal parts: 100 MΩ minimum (500V DC megger) Between terminals of different poles: 100 MΩ minimum (500V DC megger)
Impulse Withstand Voltage	1.5 kV
Operating Frequency	1,200 operations per hour
Mechanical Durability	Position 1 → 2 → 1: 1,000,000 operations minimum Position 1 → 2 → 3 → 1: 100,000 operations minimum
Electrical Durability	100,000 operations minimum
Shock Resistance	Operating extremes: 150 m/s <sup>2</sup> Damage limits: 500 m/s <sup>2</sup>
Vibration Resistance	Operating extremes: 5 to 55 Hz, amplitude 0.5 mm Damage limits: 16.7 Hz, amplitude 1.5 mm
Terminal Style	Solder terminal
Applicable Wire	1 cable, 0.5 mm <sup>2</sup> maximum
Terminal Soldering Heat Resistance	310 to 350°C, 3 seconds maximum
Terminal Tensile Strength	20N minimum
Locking Ring Recommended Tightening Torque	0.68 to 0.88 N-m
Degree of Protection	IP40 (without rubber boot) IP65 (with rubber boot) (IEC 60529)
Conditional Short-circuit Current	50A (250V) (Use 250V/10A fast-blow fuse for short-circuit protection.)
Operator Strength	500N minimum (pressing the entire operator surface)
Weight (approx.)	14g (without rubber boot) 18g (with rubber boot)

APEM

Switches & Pilot Lights

Control Boxes

Emergency Stop Switches

Enabling Switches

Safety Products

Explosion Proof

Terminal Blocks

Relays & Sockets

Circuit Protectors

Power Supplies

LED Illumination

Controllers

Operator Interfaces

Sensors

AUTO-ID

HE2B

HE3B

HE5B

HE6B

HE2G

HE1G-L

Actuator w/ Plastic Holder

# HE3B ø16mm Rectangular Three-position Enabling Switches

## Operation Characteristics

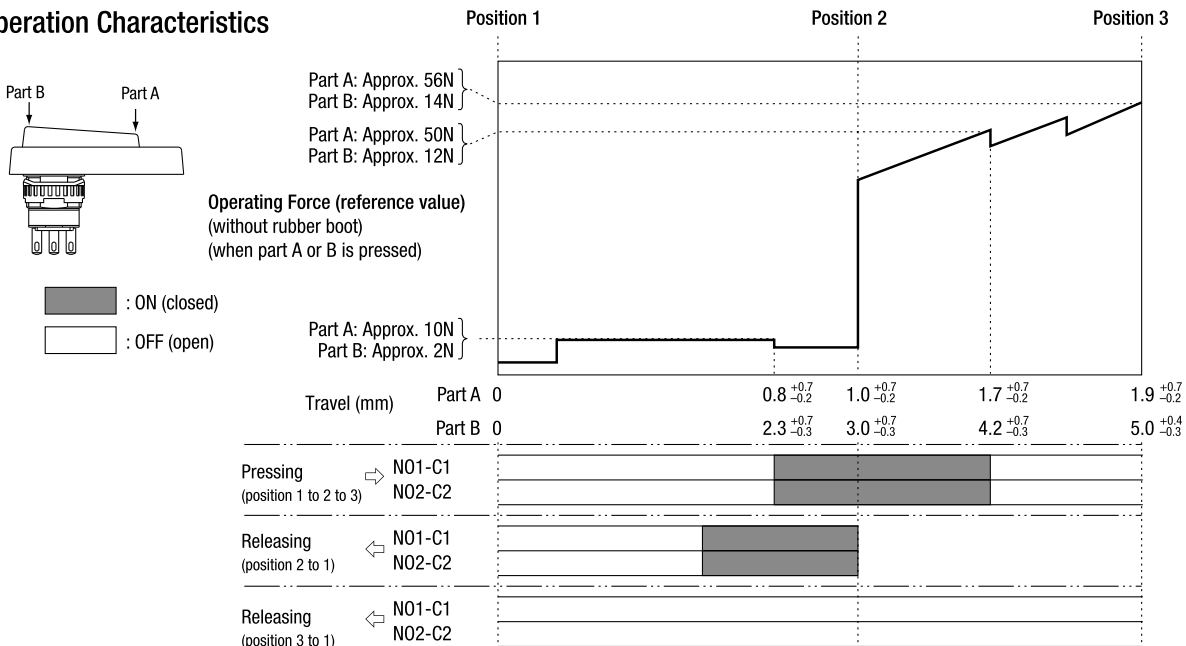

**Notes:**

- When rubber boot is used, operating force depends on the operating temperature.
- The operating force to shift the switch from position 2 to position 3 can be changed. For details, contact IDEC.

## Terminal Arrangement (Bottom View)

- 3-position switch (Note)
- 2 contacts
- Terminal No.: between NO1 and C1, between NO2 and C2
- Note: Use NO and C terminals for the 3-position switch of OFF → ON → OFF operation (NC terminal is not used).

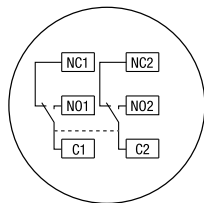

## Mounting Hole Layout

- Recommended tightening torque for locking ring: 0.68 to 0.88 N·m
- Use the locking ring wrench MT-001 for tightening.
- Note: To maintain waterproof property of the switch, do not drill through the anti-rotation hole in the mounting panel. When not providing a hole, cut off the anti-rotation projection from the rubber boot. When cutting off the projection, ensure not to make a hole in the rubber boot.

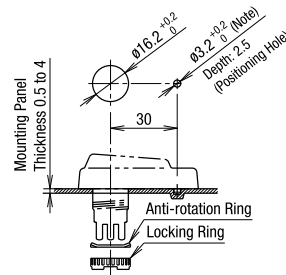

## Dimensions

### Without Rubber Boot

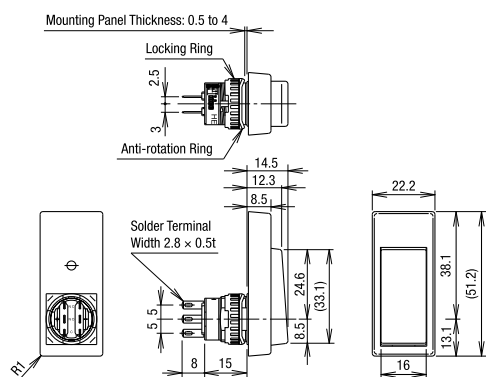

### With Rubber Boot

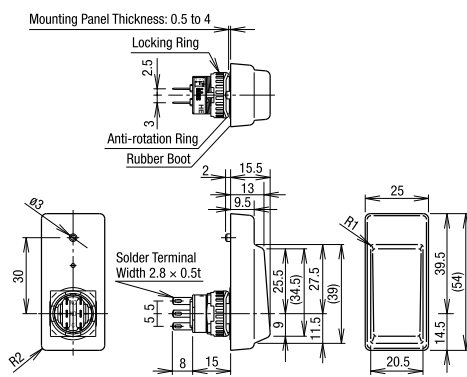

All dimensions in mm.

## Accessories

### Replacement Rubber Boot

Material	Color	Part No.	Ordering No.	Package Quantity
Silicon Rubber	Y: yellow B: black	HE9Z-D3*	HE9Z-D3*PN10	10
NBR/PVC Polyblend	Gray	HE9Z-D3N1	HE9Z-D3N1PN10	

- Specify a rubber boot color code in place of \* in the Ordering No.
- Can be installed on HE3B (without rubber boot).

### Locking Ring Wrench

Part No: MT-001  
Material: Metal



- APEM
- Switches & Pilot Lights
- Control Boxes
- Emergency Stop Switches
- Enabling Switches**
- Safety Products
- Explosion Proof
- Terminal Blocks
- Relays & Sockets
- Circuit Protectors
- Power Supplies
- LED Illumination
- Controllers
- Operator Interfaces
- Sensors
- AUTO-ID
- HE2B
- HE3B**
- HE5B
- HE6B
- HE2G
- HE1G-L
- Actuator w/ Plastic Holder

## Safety Precautions

- The enabling switches have been designed for industrial purposes. Use for residential, commercial, or lighting purposes may cause unwanted electromagnetic disturbances in which case the user may be required to take adequate mitigation measures. (IEC60947-1, Clause 5.3)
- Do not assemble or modify the enabling switches and do not disable the enabling function. Otherwise, failure of accidents may occur.
- When using the enabling switch in a safety related part of a control system, use the enabling switch properly in accordance with the safety standards and regulations of the actual machine, system, and application, of the country or region where the enabling switch is used. Also, perform a risk assessment before using the enabling switch.
- Do not disable the safety function of the enabling switch by using tape, elastic band, or by disfiguring the rubber boot, otherwise the loss of enabling switch function may cause serious accidents.
- Perform a risk assessment in actual applications as strong force may be applied to the switch when depressed to position 3.
- Perform a risk assessment for the shape and structure of the part where the enabling switch is installed, to prevent unintended operation of the enabling switch. For example, an enabling switch protruding from the teach pendant may result in an unintended operation of the enabling switch.
- Strong force may be applied to a 3-position enabling switch when pressed to position 3. Provide sufficient strength to the part where 3-position enabling switches will be installed.
- Use wires of the proper size to meet voltage and current requirements, and solder the wires correctly according to the wiring instruction described below. If soldering is incomplete, the wire may heat during operation, causing a fire hazard.
- Do not apply excessive force to the enabling switch.
- Follow the wiring instructions mentioned in the instruction manual.

## Instructions

### Operating Instructions

- The enabling switch permits machine operation only while the enabling switch is manually operated for robot teaching or other purposes in hazardous areas. Make sure that the control system is designed to activate the machine only when the enabling switch is at position 2 (3mm) operating travel.
- To achieve a high level of safety, connect the two contacts of the 3-position switch to a disparity detection circuit (e.g., safety relay module) (ISO 13849-1).
- Because two contacts are designed to operate independently, pressing the edge of a button turns on one contact earlier than the other contact, causing a delay in operation. To avoid this, always press the center of the button.
- When an enabling switch with rubber boot is mounted in a hermetically-sealed control box, a large change in internal air pressure may cause the rubber boot to inflate and deflate, affecting the performance of the enabling switch. Check periodically to make sure that the enabling switch operates correctly.
- The edge of rubber boot may stick out if excessive force is applied on the rubber boot. When such event is anticipated, it is recommended to embed the rubber boot in the mounting panel as shown in the figure below.
- Using enabling switches without rubber boots in an environment where foreign particles or dust exist may lead to malfunction. Order an optional rubber boot or add extra protection.

### Installation Instructions

- If the mounting panel is deformed, waterproof characteristics of the enabling switch with rubber boot cannot be achieved. Keep sufficient strength on the mounting panel.
- The rubber boot has a projection for positioning the enabling switch onto the mounting panel. To maintain waterproof characteristics of the switch, do not drill through the anti-rotation hole in the mounting panel. When not providing the hole, remove the anti-rotation projection from the rubber boot. When removing the projection, ensure not to make a hole in the rubber boot.
- Secure the flange part when tightening the locking ring so that the enabling switch does not rotate. When the enabling switch may rotate during operation, it is recommended to embed the switch in the mounting panel as shown below.

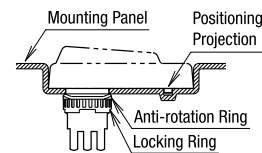

### Wiring Instructions

- Applicable wire size: 0.5 mm<sup>2</sup> maximum × 1 pc.
- Solder the terminal at a temperature of 310 to 350°C within 3 seconds using a soldering iron. Sn-Ag-Cu type is recommended when using lead-free solder. Do not use flow or dip soldering.
- When soldering, take care not to touch the enabling switch with the soldering iron. Also ensure that no tensile force is applied to the terminal. Do not bend the terminal or apply excessive force to the terminal.
- Use non-corrosive liquid rosin as soldering flux.

APEM

Switches &amp; Pilot Lights

Control Boxes

Emergency Stop Switches

Enabling Switches

Safety Products

Explosion Proof

Terminal Blocks

Relays &amp; Sockets

Circuit Protectors

Power Supplies

LED Illumination

Controllers

Operator Interfaces

Sensors

AUTO-ID

HE2B

HE3B

HE5B

HE6B

HE2G

HE1G-L

Actuator w/ Plastic Holder

# HE5B ø16mm Round Three-position Enabling Switches

Round-shaped operator for ø16 mm mounting hole.

3-position enabling switch with two contacts, ideal for installing in small teaching pendants.



• See website for details on approvals and standards.

APEM

Switches &amp; Pilot Lights

Control Boxes

Emergency Stop Switches

Enabling Switches

Safety Products

Explosion Proof

Terminal Blocks

Relays &amp; Sockets

Circuit Protectors

Power Supplies

LED Illumination

Controllers

Operator Interfaces

Sensors

AUTO-ID

HE2B

HE3B

HE5B

HE6B

HE2G

HE1G-L

Actuator w/ Plastic Holder

## HE5B

Shape	Style	Contact Configuration	Part No.	Ordering No.	Package Quantity
	With Rubber Boot Silicon Rubber Y: yellow B: black	2 contacts (3-position switch)	HE5B-M2P*	HE5B-M2P*	1
				HE5B-M2P*PN10	10
	NBR/PVC		HE5B-M2PN1	HE5B-M2PN1	1
				HE5B-M2PN1PN10	10

• Specify a rubber boot color code in place of \* in the Ordering No.

## Contact Ratings

Rated Insulation Voltage (Ui)		125V	
Rated Thermal Current (Ith)		3A	
Rated Voltage (Ue)		30V	125V
Rated Current (Ie)	AC	Resistive Load (AC-12)	– 0.5A
		Inductive Load (AC-15)	– 0.3A
DC	Resistive Load (DC-12)	1A	–
	Inductive Load (DC-13)	0.7A	–
Contact Configuration (3-position switch)		2 contacts	

Minimum applicable load (reference): 3V AC/DC, 1mA  
(Applicable operation area depends on the operating conditions and load.)

## Specifications

Applicable Standards	IEC/EN60947-5-8 (TUV approval), IEC/EN60947-5-1 UL508 (UL recognized), CSA C22.2 No. 14 (c-UL recognized), GB/T14048.5 (CCC approval)
Applicable Standards for Use	ISO12100-1, -2/EN12100-1, -2, IEC60204-1/EN60204-1 ISO11161/prEN11161, ISO10218/EN775, ANSI/RIA R15.06, ANSI B11.19
Operating Temperature	Silicon rubber boot: –25 to 60°C (no freezing) NBR/PVC Polyblend rubber boot: –10 to 60°C (no freezing)
Relative Humidity	45 to 85% (no condensation)
Storage Temperature	–40 to +80°C (no freezing)
Pollution Degree	2 (inside panel, terminal side) 3 (outside panel, operator side)
Contact Resistance	50 mΩ maximum (initial value)
Insulation Resistance	Between live and dead metal parts: 100 MΩ minimum (500V DC megger) Between terminals of different pole: 100 MΩ minimum (500V DC megger)
Impulse Withstand Voltage	1.5 kV
Operating Frequency	1,200 operations per hour
Mechanical Durability	Position 1 → 2 → 1: 1,000,000 operations minimum Position 1 → 2 → 3 → 1: 100,000 operations minimum
Electrical Durability	100,000 operations minimum
Shock Resistance	Operating extremes: 150 m/s <sup>2</sup> Damage limits: 500 m/s <sup>2</sup>
Vibration Resistance	Operating extremes: 5 to 55 Hz, amplitude 0.5 mm Damage limits: 5 to 55 Hz, amplitude 1.5 mm
Terminal Style	Solder terminal
Applicable Wire	0.5 mm <sup>2</sup> maximum per line
Terminal Soldering Heat Resistance	310 to 350°C, 3 seconds maximum
Terminal Tensile Strength	20 N minimum
Locking Ring Recommended Tightening Torque	0.29 to 0.49 N·m
Degree of Protection	IP65 (IEC 60529)
Conditional Short-circuit Current	50A (125V) (Use 250V/10A fast-blow fuse for short circuit protection.)
Operator Strength	250N minimum (when pressing the entire operator surface)
Weight (approx.)	8g (without rubber boot), 9g (with rubber boot)

## Operating Characteristics

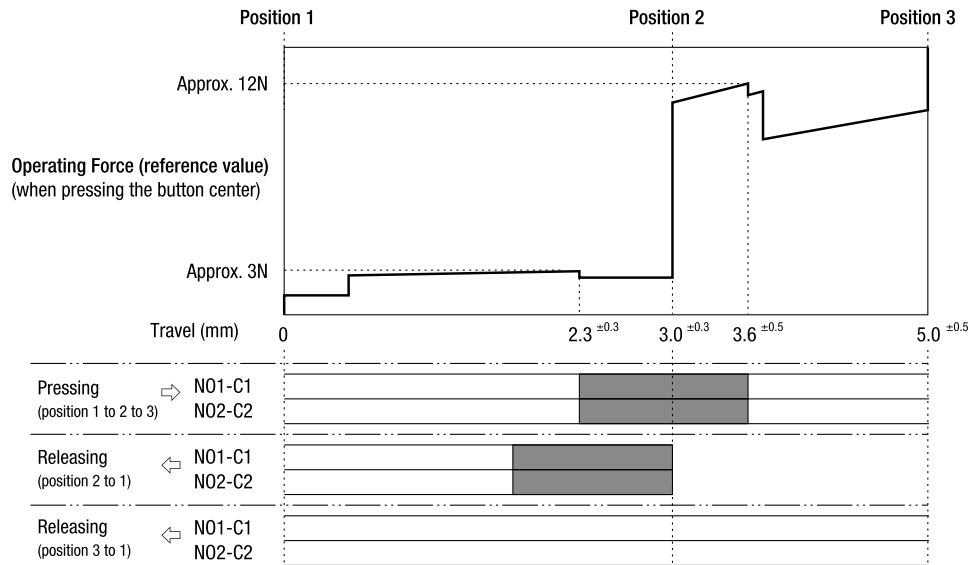

**Notes:**

- Operating force depends on ambient temperature.
- The operating force to shift the switch from position 2 to position 3 can be changed. For details, consult IDEC.

## Terminal Arrangement (Bottom View)

- 3-position switch (Note)  
2 contacts

Terminal No.: between NO1 and C1,  
NO2 and C2

Note: For OFF → ON → OFF 3-position  
switches, use NO and C terminals  
(NC terminal is not used).

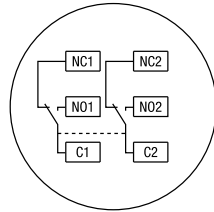

## Mounting Hole Layout

- Recommended Tightening Torque  
for Locking Ring: 0.29 to 0.49 N·m
- Use the MT-001 locking ring wrench  
for tightening.

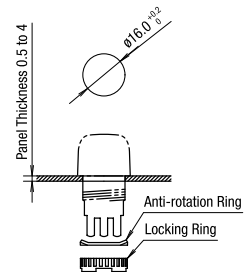

## Dimensions

With Rubber Boot

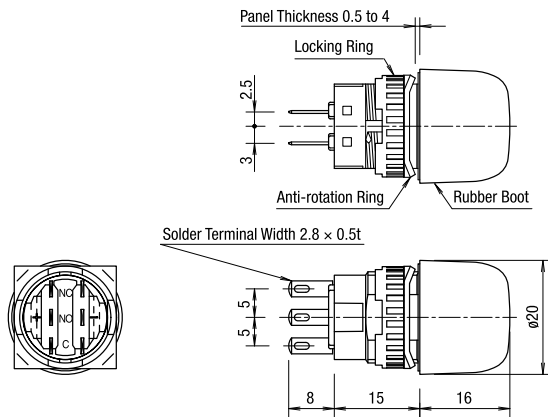

All dimensions in mm.

## Accessories

### Replacement Rubber Boot

Rubber Boot Material	Color	Part No.	Ordering No.	Package Quantity
Silicon Rubber	B: black Y: yellow	HE9Z-D5*	HE9Z-D5*PN10	10
NBR/PVC Polyblend	Gray	HE9Z-D5N1	HE9Z-D5N1PN10	

- Specify a rubber boot color code in place of \* in the Ordering No.



Locking Ring Wrench  
Part No: MT-001  
Material: Metal



- APEM
- Switches & Pilot Lights
- Control Boxes
- Emergency Stop Switches
- Enabling Switches
- Safety Products
- Explosion Proof
- Terminal Blocks
- Relays & Sockets
- Circuit Protectors
- Power Supplies
- LED Illumination
- Controllers
- Operator Interfaces
- Sensors
- AUTO-ID
- HE2B
- HE3B
- HE5B
- HE6B
- HE2G
- HE1G-L
- Actuator w/ Plastic Holder

## HE5B ø16mm Round Three-position Enabling Switches

### Grip Style Enabling Switch Housing

HE5B enabling switches can be installed in the HE9Z-GSH51 grip style enabling switch housing to be used as 3-position grip style enabling switches.

Part No.	Ordering No.	Package Quantity
HE9Z-GSH51	HE9Z-GSH51	1

#### Specifications

Category	Specification	Value
APEM	Applicable Standards	IEC/EN 60529 UL50
Switches & Pilot Lights	Operating Temperature	-25 to 60°C (no freezing)
Control Boxes	Relative Humidity	45 to 85% RH (no condensation)
	Storage Temperature	-40 to 80°C (no freezing)
Emergency Stop Switches	Pollution Degree	3
Enabling Switches	Shock Resistance	Damage limits: 500 m/s <sup>2</sup>
	Vibration Resistance	Damage limits: 5 to 55 Hz, amplitude 0.5 mm
Safety Products	Electric Shock Protection Class	Class II (when using HE5B-M2P*)
Explosion Proof	Applicable Cable	Outside diameter ø4.5 to 10 mm
Terminal Blocks	Conduit Port Size	M16 (cable gland is supplied with the grip style enabling switch housing)
Relays & Sockets	Degree of Protection	IP65 (with HE5B-M2P*) NEMA type 4X indoor use only (with HE5B-M2P*)
Circuit Protectors	Weight (approx.)	65g (grip style enabling switch housing only)



#### Notes:

- The HE9Z-GSH51 grip style enabling switch housing does not include the HE5B enabling switch. The enabling switch must be ordered separately.
- The HE5B enabling switch must be installed and wired to the HE9Z-GSH51 grip style enabling switch housing by the user. For information on wiring, see the instruction sheet supplied with the HE9Z-GSH51.

- The above specifications are for the grip style enabling switch housing only. For enabling switch, see the HE5B specifications on **D-075**
- The following switches can be installed on the grip style enabling switch housing to be used as hand-held switches.
  - AB6M pushbuttons (IP65, except for AB6M-V)
  - AS6M selector switches (IP65)
  - AS6M key selector switches (IP65)

### Dimensions

#### HE9Z-GSH51

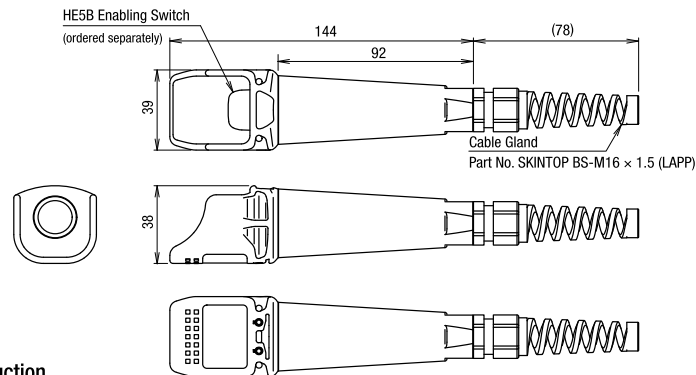

#### HE9Z-GSH51 + HE5B Construction

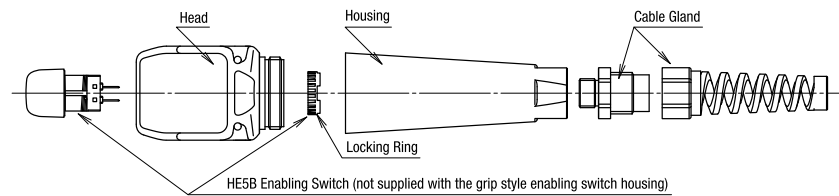

- Anti-rotation ring is not required when installing the HE5B enabling switch on the HE9Z-GSH51 grip style enabling switch housing. Use the locking ring only.

### Mounting Bracket

Part No: HE9Z-GH1

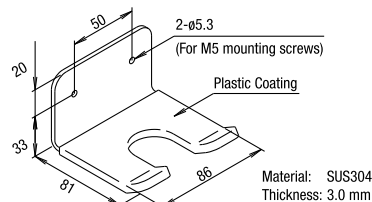

All dimensions in mm.

## ⚠ Safety Precautions

- The enabling switches have been designed for industrial purposes. Use for residential, commercial, or lighting purposes may cause unwanted electromagnetic disturbances in which case the user may be required to take adequate mitigation measures. (IEC60947-1, Clause 5.3)
- Do not assemble or modify the enabling switches and do not disable the enabling function. Otherwise, failure of accidents may occur.
- When using the enabling switch in a safety related part of a control system, use the enabling switch properly in accordance with the safety standards and regulations of the actual machine, system, and application, of the country or region where the enabling switch is used. Also, perform a risk assessment before using the enabling switch.
- Do not disable the safety function of the enabling switch by using tape, elastic band, or by disfiguring the rubber boot, otherwise the loss of enabling switch function may cause serious accidents.
- Perform a risk assessment in actual applications as strong force may be applied to the switch when depressed to position 3.
- Perform a risk assessment for the shape and structure of the part where the enabling switch is installed, to prevent unintended operation of the enabling switch. For example, an enabling switch protruding from the teach pendant may result in an unintended operation of the enabling switch.
- Strong force may be applied to a 3-position enabling switch when pressed to position 3. Provide sufficient strength to the part where 3-position enabling switches will be installed.
- Operator strength is 250N. If the expected operating force exceeds 250N, use a separate actuator with a stopper.
- Use wires of the proper size to meet voltage and current requirements, and solder the wires correctly according to the wiring instruction described below. If soldering is incomplete, the wire may heat during operation, causing a fire hazard.
- Do not apply excessive force to the enabling switch.
- Follow the wiring instructions mentioned in the instruction manual.

## Instructions

### Operating Instructions

- The enabling switch permits machine operation only while the enabling switch is manually operated for robot teaching or other purposes in hazardous areas. Make sure that the control system is designed to activate the machine only when the enabling switch is at position 2 (3mm) operating travel.
- To achieve a high level of safety, connect the two contacts of the 3-position switch to a disparity detection circuit (e.g., safety relay module) (ISO 13849-1).
- Because two contacts are designed to operate independently, pressing the edge of a button turns on one contact earlier than the other contact, causing a delay in operation. To avoid this, always press the center of the button.
- When an enabling switch with rubber boot is mounted in a hermetically-sealed control box, a large change in internal air pressure may cause the rubber boot to inflate and deflate, affecting the performance of the enabling switch. Check periodically to make sure that the enabling switch operates correctly.
- The edge of rubber boot may stick out if excessive force is applied on the rubber boot. When such event is anticipated, it is recommended to embed the rubber boot in the mounting panel as shown in the figure below.
- Using enabling switches without rubber boots in an environment where foreign particles or dust exist may lead to malfunction. Order an optional rubber boot or add extra protection.

### Installation Instructions

- If the mounting panel is deformed, waterproof characteristics of the enabling switch with rubber boot cannot be achieved. Keep sufficient strength on the mounting panel.

### HE9Z-GSH51 Grip Style Enabling Switch Housing

- Recommended Tightening Torque

	Parts for tightening	Torque
A	Head and body	0.8 to 1.2 N·m
B	Body and cable gland	$2.7 \pm 3.3$ N·m
C	Cable gland	$2.7 \pm 3.3$ N·m

- The recommended tightening torques of B and C are for the supplied cable gland. When using another cable gland, refer to the tightening torque of the cable gland used.

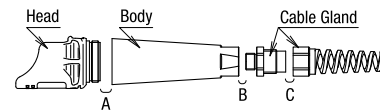

### Wiring Instructions

- Applicable wire size:  $0.5 \text{ mm}^2$  maximum  $\times$  1 pc.
- Solder the terminal at a temperature of 310 to 350°C within 3 seconds using a soldering iron. Sn-Ag-Cu type is recommended when using lead-free solder. Do not use flow or dip soldering.
- When soldering, take care not to touch the enabling switch with the soldering iron. Also ensure that no tensile force is applied to the terminal. Do not bend the terminal or apply excessive force to the terminal.
- Use non-corrosive liquid rosin as soldering flux.

APEM

Switches &amp; Pilot Lights

Control Boxes

Emergency Stop Switches

Enabling Switches

Safety Products

Explosion Proof

Terminal Blocks

Relays &amp; Sockets

Circuit Protectors

Power Supplies

LED Illumination

Controllers

Operator Interfaces

Sensors

AUTO-ID

HE2B

HE3B

HE5B

HE6B

HE2G

HE1G-L

Actuator w/ Plastic Holder

# HE6B Rectangular Three-position Enabling Switches

3-position enabling switch with monitoring contacts—Smallest in its class.



• See website for details on approvals and standards.

- APEM
- Switches & Pilot Lights
- Control Boxes
- Emergency Stop Switches
- Enabling Switches**
- Safety Products
- Explosion Proof
- Terminal Blocks
- Relays & Sockets
- Circuit Protectors
- Power Supplies
- LED Illumination
- Controllers
- Operator Interfaces
- Sensors
- AUTO-ID
- HE2B
- HE3B
- HE5B
- HE6B**
- HE2G
- HE1G-L
- Actuator w/ Plastic Holder

## HE6B

	Style		Contact Configuration/No. of Contacts			Part No.	Ordering No.	Package Quantity
			3-position Switch	Return Monitor Switch	Depress Monitor Switch			
	With Rubber Boot	Rubber Boot Material: Silicon Rubber Color: Y: yellow B: black	2	0	0	HE6B-M200*	HE6B-M200*	1
						HE6B-M200*PN10	10	
			2	1	1	HE6B-M211*	1	
						HE6B-M211*PN10	10	

• Specify rubber boot color code in place of \* in the Part No.

## Part No. Development

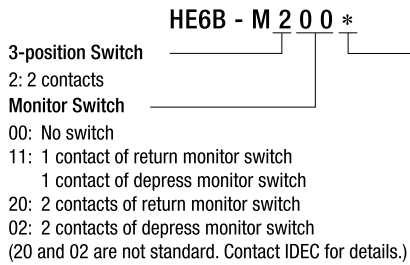

Rubber Boot Material, Color

Blank: No rubber boot

Y: Silicon rubber, yellow (Note 1)

B: Silicon rubber, black (Note 1)

[N1]: NBR/PVC polyblend, gray (Not standard. Contact IDEC) (Note 2)

Note 1: Silicon rubber: Can be used in general factories. Remaining flexible in cold temperatures. Suitable for applications in a wide operating temperature range.

Note 2: NBR/PVC polyblend: Oil-proof. Suitable for environments subjected to machine oil and for painting robots where silicon rubber cannot be used.

Specifications

Applicable Standards	IEC/EN60947-5-1 IEC/EN60947-5-8 (TÜV approval) GS-ET-22 (TÜV approval) UL508 (UL recognized) CSA C22.2 No.14 (c-UL recognized) GB/T14048.5 (CCC approval)
Applicable Standards for Use	ISO12100/EN ISO12100 IEC60204-1/EN60204-1 ISO11161/EN ISO11161 ISO10218-1/EN ISO10218-1 ANSI/RIA/ISO10218-1 ANSI/RIA/R15.06, ANSI B 11.19 ISO13849-1/EN ISO13849-1
Operating Temperature	-25 to +60°C (no freezing)
Relative Humidity	45 to 85% RH (no condensation)
Storage Temperature	-40 to +80°C (no freezing)
Pollution Degree	2 (inside panel, terminal side) 3 (outside panel, operator side)
Contact Resistance	50 mΩ maximum (initial value)
Insulation Resistance	Between live and dead metal parts: 100 MΩ minimum (500V DC megger) Between terminals of different poles: 100 MΩ minimum (500V DC megger)
Impulse Withstand Voltage	1.5 kV (3 position switch) 2.5 kV (monitor switch)
Operating Frequency	1200 operations per hour
Mechanical Durability	Position 1→2→1: 1,000,000 operations minimum Position 1→2→3→1: 100,000 operations minimum
Electrical Durability	100,000 operations minimum (rated load) 1,000,000 operations minimum (24V AC/DC, 100 mA)
Shock Resistance	Operating extremes: 150 m/s <sup>2</sup> Damage limits: 500 m/s <sup>2</sup>
Vibration Resistance	Operating extremes: 5 to 55 Hz, amplitude 0.5 mm Damage limits: 16.7 Hz, amplitude 1.5 mm
Terminal Style	Solder terminal
Applicable Wire	1 cable, 0.5 mm <sup>2</sup> maximum
Solder Terminal Heat Resistance	310 to 350°C, 3 seconds maximum
Terminal Tensile Strength	20N minimum
Locking Ring Recommended Tightening Torque	0.5 to 0.8 N·m
Degree of Protection	IP65 (IEC 60529)
Conditional Short-circuit Current	50A (125V): 3-position switch (Use 120V/10A fast acting type fuse for short circuit protection.) (IEC 60127-1) 50A (250V): monitor switch (Use 250V/10A fast acting type fuse for short circuit protection.) (IEC 60127-1)
Direct Opening Force	40N minimum (monitor switch)
Direct Opening Stroke (when pressing the entire button surface)	0.9 mm minimum (return monitor switch) 4.0 mm minimum (depress monitor switch)
Operator Strength	250N minimum (when pressing the entire button surface)
Weight (approx.)	14g (without rubber boot), 17g (with rubber boot)

Ratings

Rated Insulation Voltage (Ui)		125V (monitor switch: 250V)				
Rated Thermal Current (Ith)		3A				
Rated Voltage (Ue)		30V	125V	250V		
Rated Current (Ie)	3-position switch	AC	Resistive Load (AC-12)	—	0.5A	—
		DC	Resistive Load (DC-12)	1A	—	—
	Return monitor switch Depress monitor switch (NC)	AC	Resistive Load (AC-12)	—	2.5A	1.5A
			Inductive Load (AC-15)	—	1.5A	0.75A
		DC	Resistive Load (DC-12)	2.5A	1.1A	0.55A
			Inductive Load (DC-13)	2.3A	0.55A	0.27A
Contact Configuration	3-position switch	2 contacts				
	Return monitor switch	0 to 1 contact				
	Depress monitor switch	0 to 1 contact				

- Minimum applicable load (reference value): 3V AC/DC, 5 mA (Applicable operation area depends on the operating conditions and load.)

TÜV ratings:

3 position switch:  
AC-12 125V/0.5A  
DC-12 30V/1A  
DC-13 30V/0.7A

Monitor Switch:

AC-15 250V/0.75A  
DC-13 125V/0.22A  
DC-13 30V/2.3A

UL ratings:

3-position switch:  
125V AC/0.5A (Resistive)  
30V DC/1A (Resistive)  
30V DC/0.7A (Pilot Duty)

Monitor switch:

250V AC/0.5A (General use)  
30V DC/1A (General use)  
250V AC/0.75A (Pilot Duty)  
30V DC/2.3A (Pilot Duty)

Operating Characteristics

HE6B-M211

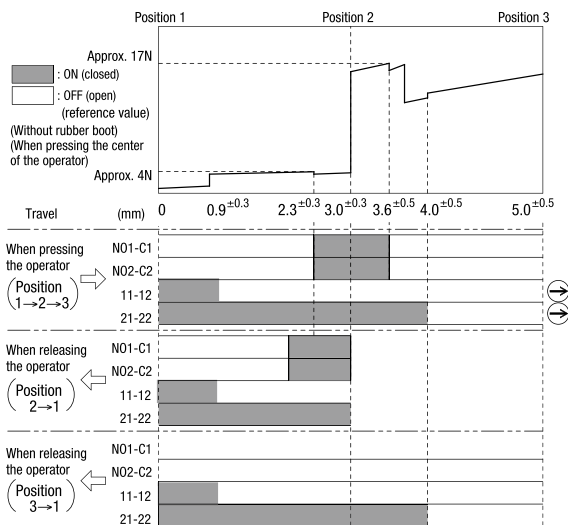

Notes:

- When a rubber boot is used, the operating force depends on the operating temperature.
- The operating force to move the button from position 2 to position 3 can be changed. For details, contact IDEC.

- APEM
- Switches & Pilot Lights
- Control Boxes
- Emergency Stop Switches
- Enabling Switches
- Safety Products
- Explosion Proof
- Terminal Blocks
- Relays & Sockets
- Circuit Protectors
- Power Supplies
- LED Illumination
- Controllers
- Operator Interfaces
- Sensors
- AUTO-ID
- HE2B
- HE3B
- HE5B
- HE6B
- HE2G
- HE1G-L
- Actuator w/ Plastic Holder

# HE6B Rectangular Three-position Enabling Switches

## Dimensions

All dimensions in mm.

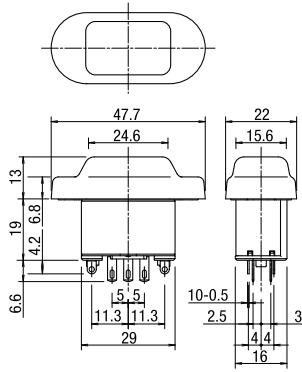

## Terminal Arrangement (bottom view)

### HE6B-M211

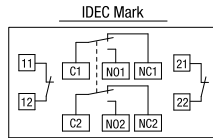

- 3-position switch (Note): 2 contacts
- Return monitor switch: 1 contact, terminal nos. 11-12
- Depress monitor switch: 1 contact, terminal nos. 21-22
- There are no terminal nos. 11-22 and 21-22 for HE6B-M200.

Note: Use NO and C terminals for OFF → ON → OFF 3-position switch (NC terminal is not used.)

## Mounting Hole Layout

All dimensions in mm.

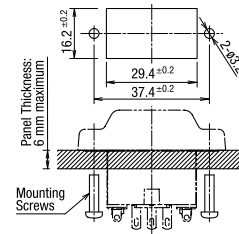

- Mounting screws: M3 screw × 2 (not attached and must be supplied by the user)
- Mounting screw length: 5 to 6 mm (panel thickness + gasket)

## Accessories

### Replacement Rubber Boot

Material, Color	Part No.	Ordering No.	Package Quantity
Silicon Rubber			
Y: yellow	HE9Z-D6*	HE9Z-D6*PN10	10
B: black			



- Specify rubber boot color code in place of \* in the Ordering No.

- APEM
- Switches & Pilot Lights
- Control Boxes
- Emergency Stop Switches
- Enabling Switches
- Safety Products
- Explosion Proof
- Terminal Blocks
- Relays & Sockets
- Circuit Protectors
- Power Supplies
- LED Illumination
- Controllers
- Operator Interfaces
- Sensors
- AUTO-ID

- HE2B
- HE3B
- HE5B
- HE6B
- HE2G
- HE1G-L
- Actuator w/ Plastic Holder

## Safety Precautions

- The enabling switches have been designed for industrial purposes. Use for residential, commercial, or lighting purposes may cause unwanted electromagnetic disturbances in which case the user may be required to take adequate mitigation measures. (IEC60947-1, Clause 5.3)
- Do not assemble or modify the enabling switches and do not disable the enabling function. Otherwise, failure of accidents may occur.
- When using the enabling switch in a safety related part of a control system, use the enabling switch properly in accordance with the safety standards and regulations of the actual machine, system, and application, of the country or region where the enabling switch is used. Also, perform a risk assessment before using the enabling switch.
- Do not disable the safety function of the enabling switch by using tape, elastic band, or by disfiguring the rubber boot, otherwise the loss of enabling switch function may cause serious accidents.
- Perform a risk assessment in actual applications as strong force may be applied to the switch when depressed to position 3.
- Perform a risk assessment for the shape and structure of the part where the enabling switch is installed, to prevent unintended opera-

tion of the enabling switch. For example, an enabling switch protruding from the teach pendant may result in an unintended operation of the enabling switch.

- Strong force may be applied to a 3-position enabling switch when pressed to position 3. Provide sufficient strength to the part where 3-position enabling switches will be installed.
- Use wires of the proper size to meet voltage and current requirements, and solder the wires correctly according to the wiring instruction described below. If soldering is incomplete, the wire may heat during operation, causing a fire hazard.
- Do not apply excessive force to the enabling switch.
- Follow the wiring instructions mentioned in the instruction manual.
- If multiple safety components are wired in series, the Performance Level to EN ISO 13849-1 will be reduced due to the restricted error detection under certain circumstance.
- The entire concept of the control system, in which the safety component is integrated, must be validated to EN ISO 13849-2.

## Instructions

### Operating Instructions

- The enabling switch permits machine operation only while the enabling switch is manually operated for robot teaching or other purposes in hazardous areas. Make sure that the control system is designed to activate the machine only when the enabling switch is at position 2 (3mm) operating travel.
- To achieve a high level of safety, connect the two contacts of the 3-position switch to a disparity detection circuit (e.g., safety relay module) (ISO 13849-1).
- Because two contacts are designed to operate independently, pressing the edge of a button turns on one contact earlier than the other contact, causing a delay in operation. To avoid this, always press the center of the button.
- When an enabling switch with rubber boot is mounted in a hermetically-sealed control box, a large change in internal air pressure may cause the rubber boot to inflate and deflate, affecting the performance of the enabling switch. Check periodically to make sure that the enabling switch operates correctly.
- If the mounting panel is deformed, waterproof characteristics of the enabling switch with rubber boot cannot be achieved. Keep sufficient strength on the mounting panel.
- The ridge on the bottom of rubber boot serves as a seal, and waterproof characteristics are attained when the ridge is tightly pressed to the mounting panel. When the mounting panel is bent and the ridge cannot be pressed to the panel, add a reinforcing rib to secure the boot to the mounting panel.
- The edge of rubber boot may stick out if excessive force is applied on the rubber boot. When such event is anticipated, it is recommended to embed the rubber boot in the mounting panel as shown in the figure below.

- The edge of rubber boot may stick out if excessive force is applied on the rubber boot. When such event is anticipated, it is recommended to embed the rubber boot in the mounting panel as shown in the figure below.

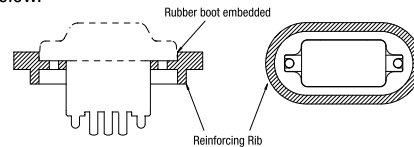

- Using enabling switches without rubber boots in an environment where foreign particles or dust exist may lead to malfunction. Order an optional rubber boot or add extra protection.

### Installation Instructions

- If the mounting panel is deformed, waterproof characteristics of the enabling switch cannot be achieved. Keep sufficient strength on the mounting panel.

### Wiring Instructions

- Applicable wire size: 0.5 mm<sup>2</sup> maximum × 1 pc.
- Solder the terminal at a temperature of 310 to 350°C within 3 seconds using a soldering iron. Sn-Ag-Cu type is recommended when using lead-free solder. Do not use flow or dip soldering.
- When soldering, take care not to touch the enabling switch with the soldering iron. Also ensure that no tensile force is applied to the terminal. Do not bend the terminal or apply excessive force to the terminal.
- Use non-corrosive liquid rosin as soldering flux.

APEM

Switches &amp; Pilot Lights

Control Boxes

Emergency Stop Switches

Enabling Switches

Safety Products

Explosion Proof

Terminal Blocks

Relays &amp; Sockets

Circuit Protectors

Power Supplies

LED Illumination

Controllers

Operator Interfaces

Sensors

AUTO-ID

HE2B

HE3B

HE5B

HE6B

HE2G

HE1G-L

Actuator w/ Plastic Holder

## Grip Style Three-position Enabling Switches

# HE2G



Compact, light-weight grip switch provides a comfortable hold

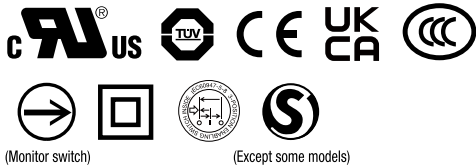

• See website for details on approvals and standards.

## Select from a wide variety of models

Equipped with different control units for various use.

<ul style="list-style-type: none"> <li>• HE2G-21SHE-L-L Emergency Stop Switch XA1E-BV3U02R</li> </ul> <p>A: Momentary Pushbutton (white) AB6M-M2PLW B: Momentary Pushbutton (white) AB6M-M2PLW</p>	<ul style="list-style-type: none"> <li>• HE2G-21SHE-L-K Emergency Stop Switch XA1E-BV3U02R</li> </ul> <p>A: Momentary Pushbutton (white) AB6M-M2PLW B: Key Selector AS6M-2KT2PA</p>	<ul style="list-style-type: none"> <li>• HE2G-21SHE-P-O Emergency Stop Switch XA1E-BV3U02R</li> </ul> <p>C: Pilot Light (green) UP9P-2498G</p>
--	---	--

## Compact design fits comfortably in the hand

The curved grip and small-size makes operation comfortable. The light-weight (approx. 140g, HE2G-21SH) and compact size is suitable for operators with small hands and for use in tight working environments.



## 3-position switch with distinctive tactile feedback

Tactile clicking feedback allows easy recognition of switch operation when shifting from position 1 (contact OFF) to position 2 (contact ON).

## Dual enabling contacts ensure a high level of safety

Dual enabling contacts with a separate actuator for each contact is IDEC's original design. This ensures a higher safety level. Disparity detection of category 4 (ISO 13849-1) can be achieved by using this switch with a safety relay module or a safety controller.

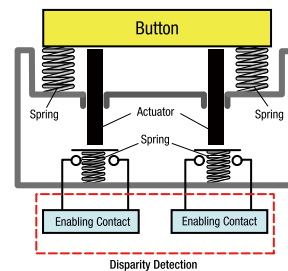

## Actuators with plastic holders, applicable for HS5 series interlock switches, can be used with the HE2G

Example of automatic and manual operation modes when HS5D is used



Operation modes can be changed by inserting/removing the actuator with plastic holder installed to the HE2G into the HS5D. When the actuator is inserted, the operation is in automatic mode. When the actuator is removed, the operation is in manual mode.

	Model	Page
	HE2G	D-084
	HE1G-L	D-089

# HE2G Grip Style Three-position Enabling Switches

New compact, light-weight grip style enabling switch provides a comfortable hold



## HE2G

3-Position Switch	Monitor Switch	Contact Configuration				Rubber Boot Material / Color	Wiring Style	Part No.
		Additional Switches (Note 1)						
		Emergency Stop Switch	Switch (A)	Switch (B)	Pilot Switch (green) (C)			
2 contacts	With (1NC)	Without				Silicon Rubber / (Yellow) (Note 2)	Solder Terminal	HE2G-21SH
		Without					NBR/PVC Polyblend / (Gray) (Note 3)	Internal Connector
		With (2NC)	Without		Without	Silicon Rubber / (Yellow) (Note 2)		Solder Terminal
		Without	Momentary Pushbutton (DPDT)		With		Internal Connector	HE2G-21SC-1N
		With (2NC)	Momentary Pushbutton (DPDT)	Key Selector Switch (DPDT)	Without		Solder Terminal	HE2G-21SHE
							Solder Terminal	HE2G-21SHE-P-0
		With (2NC)	Momentary Pushbutton (DPDT)	Key Selector Switch (DPDT)	Without		Solder Terminal	HE2G-21SH-L-L
							Solder Terminal	HE2G-21SHE-L-L
							Internal Connector	HE2G-21SCE-L-L
							Solder Terminal	HE2G-21SHE-L-K
Internal Connector	HE2G-21SCE-L-K							

Note 1: Additional switches installed on the HE2G are as follows:

- Emergency Stop Switch: XA1E-BV3U02R
- Momentary Pushbutton: AB6M-M2PLW
- Key Selector Switch: AS6M-2KT2PA
- Pilot Light: UP9P-2498G

Note 2: Silicon rubber: Can be used in general factories. Remains flexible in cold temperatures. Suitable in applications with a wide operating temperature range.

Note 3: NBR/PVC polyblend: Oil-proof. Suitable for environments subjected to machine oil and painting robots where silicon rubber cannot be used.

## Additional Switch Layout

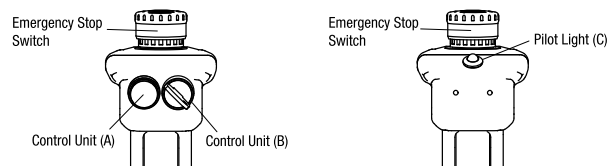

APEM

Switches & Pilot Lights

Control Boxes

Emergency Stop Switches

Enabling Switches

Safety Products

Explosion Proof

Terminal Blocks

Relays & Sockets

Circuit Protectors

Power Supplies

LED Illumination

Controllers

Operator Interfaces

Sensors

AUTO-ID

HE1B

HE2B

HE3B

HE5B

HE6B

HE2G

HE1G-L

Actuator w/ Plastic Holder

# HE2G Grip Style Three-position Enabling Switches

## Contact Ratings

Rated Insulation Voltage (Ui)			250V (momentary pushbutton and key selector: 125V) / 30V (with pilot light)				
Rated Thermal Current (Ith)			3A (emergency stop switch: 5A)*				
Rated Voltage (Ue)			30V	125V	250V		
Rated Current	Grip Style Enabling Switch	AC	Resistive Load (AC-12)	—	1A	0.5A	
			Inductive Load (AC-15)	—	0.7A	0.5A	
		DC	Resistive Load (DC-12)	1A	0.2A	—	
			Inductive Load (DC-13)	0.7A	0.1A	—	
		Monitor Switch (NC contact) (Terminal No. 31-32/A2-B2)	AC	Resistive Load (AC-12)	—	2.5A	1.5A
				Inductive Load (AC-15)	—	1.5A	0.75A
	DC		Resistive Load (DC-12)	2.5A	1.1A	0.55A	
			Inductive Load (DC-13)	2.3A	0.55A	0.27A	
	Emergency Stop Switch XA1E-BV3U02 (Terminal No. 1-2/A1-B1, 1-2/A2-B2)	AC	Resistive Load (AC-12)	—	5A	3A	
			Inductive Load (AC-15)	—	3A	1.5A	
		DC	Resistive Load (DC-12)	2A	0.4A	0.2A	
			Inductive Load (DC-13)	1A	0.22A	0.1A	
Momentary Pushbutton Key Selector Switch AB6M-M2PLW, AS6M-2KT2PA (Terminal No. C1/B1, N01/B2, NC1/B3, C2/A1, N02/A2, NC2/A3)	AC	Resistive Load (AC-12)	—	0.5A	—		
		Inductive Load (AC-15)	—	0.3A	—		
	DC	Resistive Load (DC-12)	1A	0.2A	—		
		Inductive Load (DC-13)	0.7A	0.1A	—		
UP9 Pilot Light UP9P-2498G (Terminal No. +, -)			Rated operating voltage: 24V DC ±10% Rated current: 15mA				

Note: Minimum applicable load (reference value): 3V AC/DC, 5 mA (Applicable range is subject to the operating conditions and load.)

\*Operating temperature for internal connectors:  
 -25°C min., 40°C max. 2.5A (12 to 19 poles), 2A (20 to 22 poles)  
 40°C min., 50°C max. 2.5A (8 to 12 poles), 2A (13 to 22 poles)  
 50°C min., 60°C max. 2.5A (6, 7 poles), 2A (8 to 13 poles), 1.5A (14 to 22 poles)

## Specifications

Applicable Standards	IEC60947-5-1 EN60947-5-1 (TÜV approval) JIS C8201-5-1 IEC60847-5-8, EN60947-5-8(TÜV approval) GS-ET-22(TÜV approval) UL508 (UL recognized) CSA C22.2 No.14 (c-UL recognized) GB14048.5 (CCC approval) KS C IEC60947-5-1/S1-G-1 (KOSHA approval)
Applicable Standards for Use	ISO12100/EN ISO12100 IEC60204-1/EN60204-1 ISO11161/EN ISO11161 ISO10218-1/EN ISO10218-1 ANSI/RIA/ISO10218-1 ANSI/RIA R15.06, ANSI B11.19 ISO13849-1/EN ISO13849-1
Operating Temperature	Silicon rubber boot: -25 to 60°C (no freezing) NBR/PVC Polyblend rubber boot: -10 to 60°C (no freezing)
Relative Humidity	45 to 85% (no condensation)
Storage Temperature	-40 to +80°C (no freezing)
Pollution Degree	3
Contact Resistance	50 mΩ maximum (initial value)
Insulation Resistance	Between live and dead metal parts: 100 MΩ minimum (500V DC megger) Between terminals of different pole: 100 MΩ minimum (500V DC megger)
Impulse Withstand Voltage	(Solder terminal) Grip style enabling switch/emergency stop switch: 2.5 kV Momentary pushbutton/key selector switch: 1.5 kV Pilot light: 500V AC, 1 minute (between live and dead parts) (Internal connector) Grip style enabling switch/emergency stop switch/ momentary pushbutton/key selector switch: 1.5 kV
Electric Shock Protection Class	Class II (IEC 61140) (With pilot light: class III)
Operating Frequency	1,200 operations per hour
Mechanical Durability	Position 1 → 2 → 1: 1,000,000 operations minimum Position 1 → 2 → 3 → 1: 100,000 operations minimum
Electrical Durability	100,000 operations minimum (rated load) 1,000,000 operations minimum (24V AC/DC, 100 mA)
Shock Resistance	Operating extremes: 150 m/s <sup>2</sup> Damage limits: 1,000 m/s <sup>2</sup>
Vibration Resistance	Operating extremes: 5 to 55 Hz, amplitude 0.5 mm minimum Damage limits: 16.7 Hz, amplitude 1.5 mm minimum
Applicable Wire	Solder terminal: 0.5 mm <sup>2</sup> maximum Internal connector: 0.05 to 0.86 mm <sup>2</sup> (AWG18 to 30)
Applicable Wire Size	Solder terminal: 0.5 mm <sup>2</sup> Internal connector: 0.05 to 0.86 mm <sup>2</sup> (AWG18 to 30) (AWG22 between switch and connector)
Applicable Cable	Outside diameter: ø4.5 to 10 mm
Conduit Port Size	M16 (cable gland is supplied)
Terminal Tensile Strength	20N minimum
Degree of Protection	Without switch/pilot light IP67/66 With switch/pilot light IP65
Conditional Short-circuit Current	50A (250V) (Use 250V/10A fast-blow fuse for short circuit protection.)
Direct Opening Force	60N minimum (monitor switch)
Operator Strength	500N minimum (when pressing the entire button surface)
Free Fall	1.0m 1 fall (IEC 60068-2-32 compliant)
Weight (approx.)	HE2G-21SH: 140g HE2G-21SH-P-0/-21SC: 145g HE2G-21SHE/-21SC-P-0: 150g HE2G-21SH-L-L/-21SHE-P-0/-21SCE: 155g HE2G-21SH-L-K/-21SCE-P-0: 160g HE2G-21SHE-L-L/-21SC-L-L: 165g HE2G-21SHE-L-K/-21SC-L-K: 170g HE2G-21SCE-L-L: 175g HE2G-21SCE-L-K: 180g

Operation Characteristics

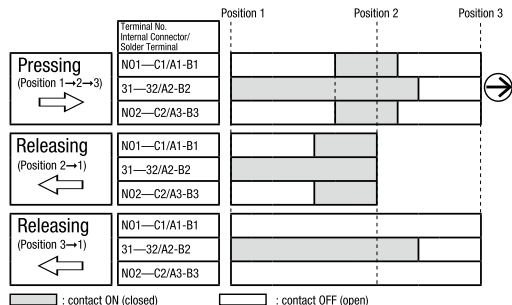

- Terminals NO1-C1/A1-B1, NO2-C2/A3-B3 are outputs of the 3-position enabling switch.
- The above operation characteristics show when the center of the grip style enabling switch button is pressed. Because two contacts are designed to operate independently, pressing the edge of the button turns on one contact earlier than the other contact, causing a delay in operation. To avoid this, always press the center of the button.

Contact Arrangement (Internal Connector)

Internal Connector Pin No.

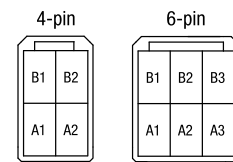

- Emergency stop switch
- 3-position switch
- Momentary pushbutton
- Key selector switch

3-position switch / switch side connector:  
 Tyco Electronics D-1200D Series  
 Tab housing: 1-1903130-2 (4-pin connector)  
 1-1903130-3 (6-pin connector)  
 Tab contact: 19303116-2

Terminal Arrangement (TOP VIEW)



- Emergency stop switch
- Momentary pushbutton
- Key selector switch

Dimensions

HE2G-21SH/HE2G-21SC

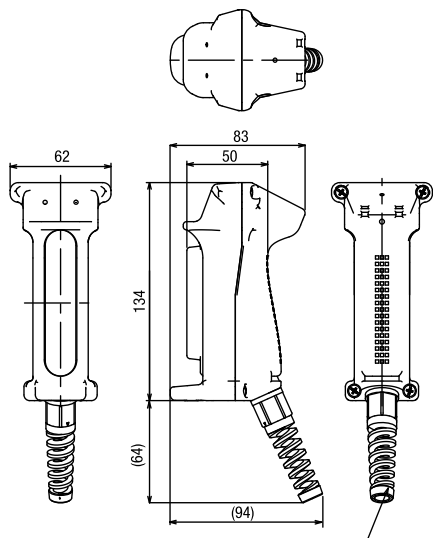

Cable Gland (supplied with grip style enabling switch)  
 Part No.: SKINTOP BS-M16 x 1.5 (LAPP)

All dimensions in mm.

Internal Connector

Cable side connector:  
 Tyco Electronics D-1200D Series

- Receptacle: 1-1827864-□
- Receptacle contact
  - 1827586-2: AWG28 to 30 (Hand tool: 1762952-1)
  - 1827587-2: AWG22 to 28 (Hand tool: 1762846-1)
  - 1827588-2: AWG22 to 28 (Hand tool: 1762950-1)
  - 1827589-2: AWG18 to 22 (Hand tool: 1762625-1)

Specify 2 or 3 in place of □.

- 2: 4-pin connector
- 3: 6-pin connector

The customer needs to purchase the connector separately.

6-Pin Connector Allotment Table

Internal Connector Pin No.	Momentary pushbutton Key selector switch
A1	C2
A2	NO2
A3	NC2
B1	C1
B2	NO1
B3	NC1

- For signal of the 3-position switch, see "Operation Characteristics".
- For solder terminal type terminal arrangement of each switch/pilot light, see each catalog.

APEM

Switches & Pilot Lights

Control Boxes

Emergency Stop Switches

Enabling Switches

Safety Products

Explosion Proof

Terminal Blocks

Relays & Sockets

Circuit Protectors

Power Supplies

LED Illumination

Controllers

Operator Interfaces

Sensors

AUTO-ID

HE1B

HE2B

HE3B

HE5B

HE6B

HE2G

HE1G-L

Actuator w/  
Plastic Holder

## HE2G Grip Style Three-position Enabling Switches

 Safety Precautions

- The enabling switches have been designed for industrial purposes. Use for residential, commercial, or lighting purposes may cause unwanted electromagnetic disturbances in which case the user may be required to take adequate mitigation measures. (IEC60947-1, Clause 5.3)
- Do not assemble or modify the enabling switches and do not disable the enabling function. Otherwise, failure of accidents may occur.
- When using the enabling switch in a safety related part of a control system, use the enabling switch properly in accordance with the safety standards and regulations of the actual machine, system, and application, of the country or region where the enabling switch is used. Also, perform a risk assessment before using the enabling switch.
- Do not hold the enabling switch to position 2 using tapes or strings. Otherwise the loss of enabling switch function may cause serious accidents.
- Do not use with the grip switch installed on a machine.
- Use wires of the proper size to meet voltage and current requirements.
- Do not apply excessive force to the enabling switch.
- Make sure that dust, water and oil do not enter the grip switch during wiring.
- Be sure to choose cables according to the operating environment.
- If multiple safety components are wired in series, the Performance Level to EN ISO 13849-1 will be reduced due to the restricted error detection under certain circumstance.
- The entire concept of the control system, in which the safety component is integrated, must be validated to EN ISO 13849-2.

## Instructions

## Operating Instructions

- This grip style three-position enabling switch is a device used for enabling a machine such as robots when teaching the machine in a hazardous area manually. Configure the enabling system so that the machine can operate when the switch is in position 2 and an separate start switch is required to initiate the system.
- To achieve a high level of safety, connect the two contacts of the 3-position switch to a disparity detection circuit (terminal No. NO1-C1 and NO2-C2) to a discrepancy detection circuit such as a safety relay module. (ISO13849-1/ EN954-1)
- The base and the plastic part of rubber boot frame are made of glass-reinforced ABS/PBT. The rubber boot is made of silicone rubber or NBR/PVC polyblend. The screw is made of iron. When cleaning the grip style three-position enabling switch, use a detergent compatible with the materials.
- When adding momentary pushbutton switch and key selector switch, do not connect NO and NC contacts of a microswitch to different voltages or different power sources to prevent a dead short-circuit.
- When operating a additionally installed key selector switch, be sure to fully insert the key. Otherwise, failure may occur.
- The rubber boot may deteriorate depending on the operating environment and conditions. When the rubber boot is deformed or cracked, replace with new ones.

## Wiring Instructions

- Solder the terminal at a temperature of 310 to 350°C within 3 seconds using a soldering iron. Sn-Ag-Cu type is recommended when using lead-free solder. Do not use flow or dip soldering.
- When soldering, take care not to touch the enabling switch with the soldering iron. Also ensure that no tensile force is applied to the terminal. Do not bend the terminal or apply excessive force to the terminal.
- Use non-corrosive liquid rosin as soldering flux.
- Because the terminal spacing is narrow, use protective tubes or heat shrinkable tubes to avoid burning of wire coating or short circuit.
- When using a stranded wire, make sure that adjoining terminals are not short-circuited
  - with protruding core wires.
- Use copper Wire 60/75 degree C only. (UL508)
- The wiring has to be installed according to GS-ET-22, 4.2.6.

APEM
Switches & Pilot Lights
Control Boxes
Emergency Stop Switches
Enabling Switches
Safety Products
Explosion Proof
Terminal Blocks
Relays & Sockets
Circuit Protectors
Power Supplies
LED Illumination
Controllers
Operator Interfaces
Sensors
AUTO-ID
HE1B
HE2B
HE3B
HE5B
HE6B
HE2G
HE1G-L
Actuator w/ Plastic Holder

Instructions

Solder Terminal

Wire Length inside the Switch

	Grip Style Enabling Switch								Momentary Pushbutton/Key Selector Switch			Emergency Stop Switch		Pilot Light	
	NO1	C1	11	12	31	32	NO2	C2	C	NO	NC	1	2	+	-
Wire stripping length L1 (mm)	40	45	50	60	50	60	85	80	120			110		115	
Wire stripping length L2 (mm)	L2=5mm														

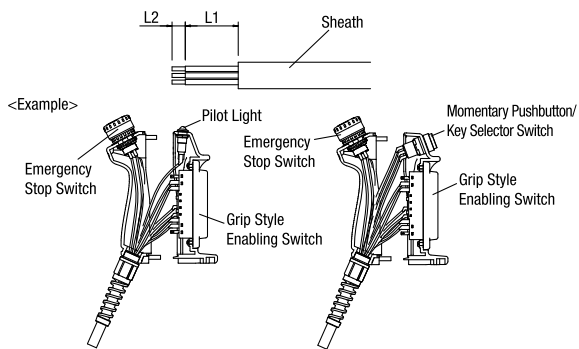

Applicable Wire Size

0.5mm<sup>2</sup> maximum (Observe the requirements of IEC 60204-1 for wiring.)

Recommended Tightening Torque

Parts for tightening		Torque
A	Base and rubber kit (M4 screw × 4)	1.1 to 1.3 N·m
B	Cable gland and grip style enabling switch	2.7 to 3.3 N·m
C	Cable gland	2.7 to 3.3 N·m
D	HE2B Enabling Switch (M3 screws × 2) *	0.5 to 0.8 N·m

Note: The recommended tightening torques of B and C are for the supplied cable gland. When using another cable gland, refer to the tightening torque of the cable gland used.

\* For replacing HE2B enabling switch or rubber boot only

mended connector is used. When using another connector, refer to the specifications of the connector used.

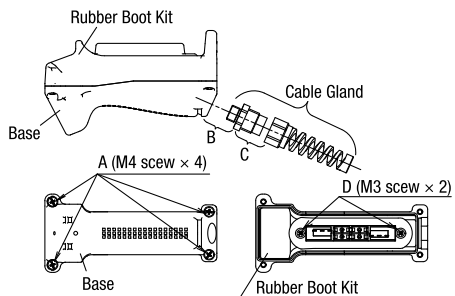

Connector Terminal

Wire Length inside the Switch

	Grip Style Enabling Switch	Momentary Pushbutton/Key Selector Switch	Emergency Stop Switch
Wire stripping length L1 (mm)	20	60	75

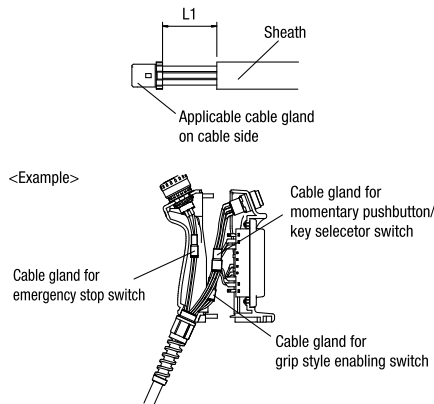

Applicable wire size for the cable gland on cable side

- 0.05 to 0.86mm<sup>2</sup> (AWG18 to 30): Check the compliance with receptacle and contact.

Tool: 1762846-1 (manual tool)

Note: When using stranded wires, make sure that loose wires do not cause short circuit. Also, do not solder the terminals to prevent loose wires. Use copper wire of 60°C or 75°C temperature rating in order to comply with UL508. Observe the requirements of GS-ET-22: 2003, 4.2.6 for wiring.

APEM

Switches & Pilot Lights

Control Boxes

Emergency Stop Switches

Enabling Switches

Safety Products

Explosion Proof

Terminal Blocks

Relays & Sockets

Circuit Protectors

Power Supplies

LED Illumination

Controllers

Operator Interfaces

Sensors

AUTO-ID

HE1B

HE2B

HE3B

HE5B

HE6B

HE2G

HE1G-L

Actuator w/ Plastic Holder

# HE1G-L Grip Style Three-position Enabling Switches

The distinctive tactile feedback makes it easy to know the current position of the switch.  
 Light operating force ideal for long-hour operation

- Ergonomically-designed OFF-ON-OFF operation.
- The switch does not turn ON when being released from position 3 (OFF when pressed) to position 1 (OFF when released) (IEC 60204-1, 9.2.5.8).
- Two contacts are provided so that even if one contact fails due to welding or short-circuit, the other contact can disable machine operation.
- Monitor switch is direct opening action.
- The distinctive tactile feedback when shifting to position 2 (enabling position) makes it easier to know where the enabling switch is currently positioned—position 1 (OFF), 2 (ON), or 3 (OFF).
- Lighter operating force on position 2 assures more comfortable, stress-free operation when operating long hours.
- Emergency stop switch and momentary pushbutton versions are available.
- Push-in terminal models can be selected.
- IP66 degree of protection (HE1G-L21SM)



## HE1G-L

Package Quantity: 1

Contact Configuration			Rubber Boot	Wiring Style	Part No.
3-position Switch	Monitor Switch	Additional Pushbutton Switch			
2 contacts	With (1NC)	Without	Silicon Rubber / yellow (Note 1) NBR/PVC Polyblend / gray (Note 2)	Push-in terminal	HE1G-L21SM HE1G-L21SM-1N
		Momentary Pushbutton Switch (1NO: AB6M-M1PB)	Silicon Rubber / yellow NBR/PVC Polyblend / gray		HE1G-L21SMB HE1G-L21SMB-1N
		Emergency Stop Switch (2NC: HA1E-V2S2R)	Silicon Rubber / yellow NBR/PVC Polyblend / gray		HE1G-L20ME HE1G-L20ME-1N
	Without	Momentary Pushbutton Switch (2NO: AB6M-M2PB)	Silicon Rubber / yellow NBR/PVC Polyblend / gray		HE1G-L20MB HE1G-L20MB-1N

Note 1: Silicon rubber: Can be used in general factories. Remains flexible at cold temperatures. Suitable to applications in a wide operating temperature range.  
 Note 2: NBR/PVC polyblend: Oil-proof. Suitable for environments subjected to machine oil and painting robot where silicon rubber cannot be used.

## Contact Ratings

Rated Insulation Voltage (Ui)		250V (momentary pushbutton: 125V)						
Rated Thermal Current (Ith)		2.5A (Note)						
Rated Voltage (Ue)		30V	125V	250V				
Rated Current (Ie)	Grip Style Enabling Switch	3-position Switch (Terminal No.1-2/3-4)	AC	Resistive Load (AC-12)	—	1A	0.5A	
			DC	Resistive Load (DC-12)	1A	0.2A	—	
		Monitor Switch (HE1G-L21SM/HE1G-L21SMB, Terminal No.5-6)	AC	Resistive Load (AC-12)	—	2.5A	1.5A	
			DC	Resistive Load (DC-12)	2.5A	1.1A	0.55A	
		Pushbutton	Emergency Stop Switch (HE1G-L20M, Terminal No. 5-6, 7-8)	AC	Resistive Load (AC-12)	—	2.5A	2.5A
				DC	Resistive Load (DC-12)	2A	0.44A	0.2A
	Momentary Pushbutton (HE1G-L20M, Terminal No.5-6,7-8) (HE1G-L21SM, Terminal No.7-8)		AC	Resistive Load (AC-12)	—	0.5A	—	
			DC	Resistive Load (DC-12)	1A	0.2A	—	

- Minimum applicable load (reference value): 3V AC/DC, 5 mA (Applicable range is subject to the operating conditions and load.)
- Note: Operating temp. 40 to up to +50°C (not included): 2A (4 circuits)  
 50 to +60°C: 1.5A (3 or 4 circuits)

Specifications

Applicable Standards	IEC60947-5-1, EN60947-5-1 (TUV approval) JIS C8201-5-1, IEC60947-5-8, EN60947-5-8 (TUV approval) GS-ET-22 (TUV approval) UL508 (UL listed) (screw terminal only) CSA C22.2 No. 14 (c-UL listed) (screw terminal only) GB/T14048.5 (CCC approval)
Applicable Standards for Use	ISO12100-1, -2/EN12100-1, -2 IEC60204-1/EN60204-1, ISO11161/prEN11161 ISO10218/EN775, ANSI/RIA R15.06 ANSI B11.19
Operating Temperature	Silicon rubber boot: -25 to 60°C (no freezing) NBR/PVC Polyblend rubber boot: -10 to 60°C (no freezing)
Relative Humidity	45 to 85% (no condensation)
Storage Temperature	-40 to +80°C (no freezing)
Pollution Degree	3
Contact Resistance	100 mΩ maximum (initial value)
Insulation Resistance	Between live and dead metal parts: 100 MΩ minimum (500V DC megger) Between terminals of different pole: 100 MΩ minimum (500V DC megger)
Impulse Withstand Voltage	Screw terminal: 2.5 kV (momentary pushbuttons: 1.5 kV) Internal connector: 1.5 kV
Electric Shock Protection Class	Class II (IEC 61140)
Operating Frequency	1,200 operations per hour
Mechanical Durability	Position 1 → 2 → 1: 1,000,000 operations minimum Position 1 → 2 → 3 → 1: 100,000 operations minimum
Electrical Durability	100,000 operations minimum (rated load) 1,000,000 operations minimum (24V AC/DC, 100 mA)
Shock Resistance	Operating extremes: 150 m/s <sup>2</sup> Damage limits: 1,000 m/s <sup>2</sup>
Vibration Resistance	Operating extremes: 5 to 55 Hz, amplitude 0.5 mm minimum Damage limits: 16.7 Hz, amplitude 1.5 mm minimum
Applicable Wire	Push-in terminal: 0.2 to 1.5 mm <sup>2</sup> (AWG16 to 25)
Applicable Cable	Outside diameter ø7 to 13 mm
Conduit Port Size	M20 (cable gland is supplied with the grip style enabling switch)
Terminal Tensile Strength	20N minimum
Degree of Protection	HE1G-L21SM: IP66 (IEC 60529) HE1G-L20ME: IP65 (IEC 60529) HE1G-L20MB: IP65 (IEC 60529) HE1G-L21SMB: IP65 (IEC 60529)
Conditional Short-circuit Current	50A (250V) (Use 250V/10A fast-blow fuse for short circuit protection.)
Direct Opening Force	70N minimum (monitor switch)
Operator Strength	500N minimum (when pressing the entire button surface)
Weight (approx.)	HE1G-L21SM: 195g HE1G-L21SMB/L20MB: 205g HE1G-L20ME: 210g

Operating Characteristics

HE1G-L21SM, HE1G-L21SM-1N

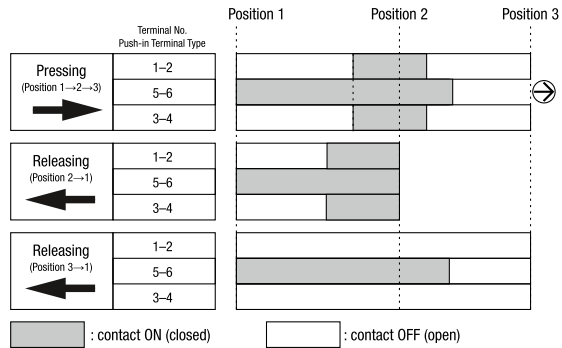

- Terminals 1-2 and 3-4 are outputs of the 3-position enabling switch.
- Terminals 5-6/A3-B3 are outputs of the monitor switch.
- The above operation characteristics show when the center of the grip style enabling switch button is pressed. Because two contacts are designed to operate independently, pressing the edge of the button turns on one contact earlier than the other contact, causing a delay in operation. To avoid this, always press the center of the button.

Dimensions

HE1G-L21SM, HE1G-L21SM-1N

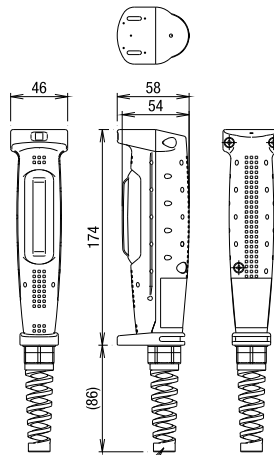

Cable Gland (supplied with grip style enabling switch)  
Part No.: SKINTOP BS-M20 x 1.5 (LAPP)

Accessory

Mounting Bracket HE9Z-GH1 (for hanging the switch)

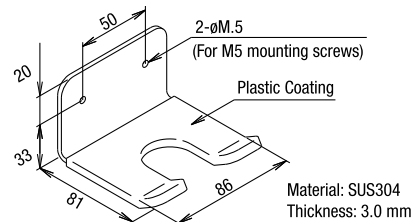

Note: Available for HE1G/HE1G-L/HE9Z-GSH51 only.

- APEM
- Switches & Pilot Lights
- Control Boxes
- Emergency Stop Switches
- Enabling Switches
- Safety Products
- Explosion Proof
- Terminal Blocks
- Relays & Sockets
- Circuit Protectors
- Power Supplies
- LED Illumination
- Controllers
- Operator Interfaces
- Sensors
- AUTO-ID
- HE1B
- HE2B
- HE3B
- HE5B
- HE6B
- HE2G
- HE1G-L
- Actuator w/ Plastic Holder

# HE1G-L Grip Style Three-position Enabling Switches

## ⚠ Safety Precautions

- The enabling switches have been designed for industrial purposes. Use for residential, commercial, or lighting purposes may cause unwanted electromagnetic disturbances in which case the user may be required to take adequate mitigation measures. (IEC60947-1, Clause 5.3)
- Do not assemble or modify the enabling switches and do not disable the enabling function. Otherwise, failure of accidents may occur.
- When using the enabling switch in a safety related part of a control system, use the enabling switch properly in accordance with the safety standards and regulations of the actual machine, system, and application, of the country or region where the enabling switch is used. Also, perform a risk assessment before using the enabling switch.
- Do not hold the enabling switch to position 2 using tapes or strings. Otherwise the loss of enabling switch function may cause serious accidents.
- Do not use with the grip switch installed on a machine.

- Use wires of the proper size to meet voltage and current requirements.
- Do not apply excessive force to the enabling switch.
- Make sure that dust, water and oil do not enter the grip switch during wiring.
- Be sure to choose cables according to the operating environment.
- If multiple safety components are wired in series, the Performance Level to EN ISO 13849-1 will be reduced due to the restricted error detection under certain circumstance.
- The entire concept of the control system, in which the safety component is integrated, must be validated to EN ISO 13849-2.

## Instructions

### Operating Instructions

- This grip style three-position enabling switch is a device used for enabling a machine such as robots when teaching the machine in a hazardous area manually. Configure the enabling system so that the machine can operate when the switch is in position 2 and an separate start switch is required to initiate the system.
- To achieve a high level of safety, connect the two contacts of the 3-position switch to a disparity detection circuit (terminal No. N01-C1 and N02-C2) to a discrepancy detection circuit such as a safety relay module. (ISO13849-1/ EN954-1)
- The base and the plastic part of rubber boot frame are made of glass-reinforced ABS/PBT. The rubber boot is made of silicone rubber or NBR/PVC polyblend. The screw is made of iron. When cleaning the grip style three-position enabling switch, use a detergent compatible with the materials.
- The rubber boot may deteriorate depending on the operating environment and conditions. When the rubber boot is deformed or cracked, replace with new ones.

### Wiring Instructions

#### Push-in Terminal Type

#### Wire Length inside the Grip Style Enabling Switch

	Terminal No. 1-4	Terminal No. 5-8
Wire stripping length L1, L2 (mm)	L1 = 35 mm	L2 = 30 mm
Wire stripping length L3 (mm)	L3 = 8 to 9 mm	

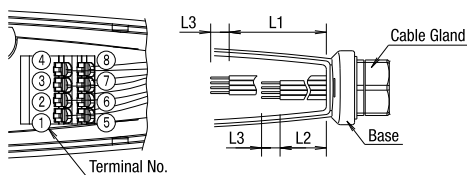

### Applicable Wire Size

<Direct wiring>

0.2 to 1.5 mm<sup>2</sup> (one wire per terminal)

Note: When using stranded wire, make sure that adjoining terminals are not short-circuited by frayed wires. Also, do not solder the wires to avoid frayed wires.

<Ferrules>

### Recommended ferrules (Phoenix Contact)

Part No.	Applicable Wire
S3TL-H025-12WJ	0.25mm <sup>2</sup>
S3TL-H034-12WT	0.34mm <sup>2</sup>
S3TL-H05-14WA	0.5mm <sup>2</sup>
S3TL-H075-14WW	0.75mm <sup>2</sup>

Crimping tool: PZ6 Roto L

### Recommended Tightening Torque

Parts for Tightening		Torque
A	Rubber boot and the base (M4 screw × 3)	1.2 ± 0.1 N·m
B	Connector and grip style enabling switch	4.0 ± 0.3 N·m
C	Connector and connector	4.0 ± 0.3 N·m
D	Do not remove screws	—

The torque of screws B and C in the table above are values when the recommended connector is used. When using another connector, refer to the specifications of the connector used.

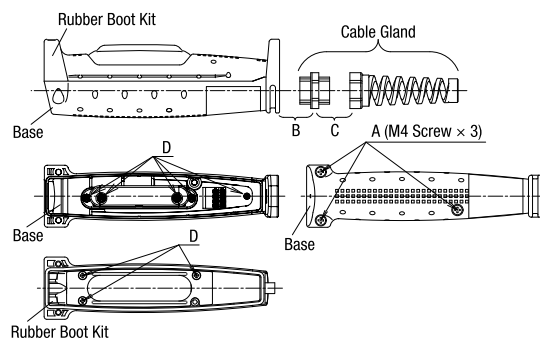

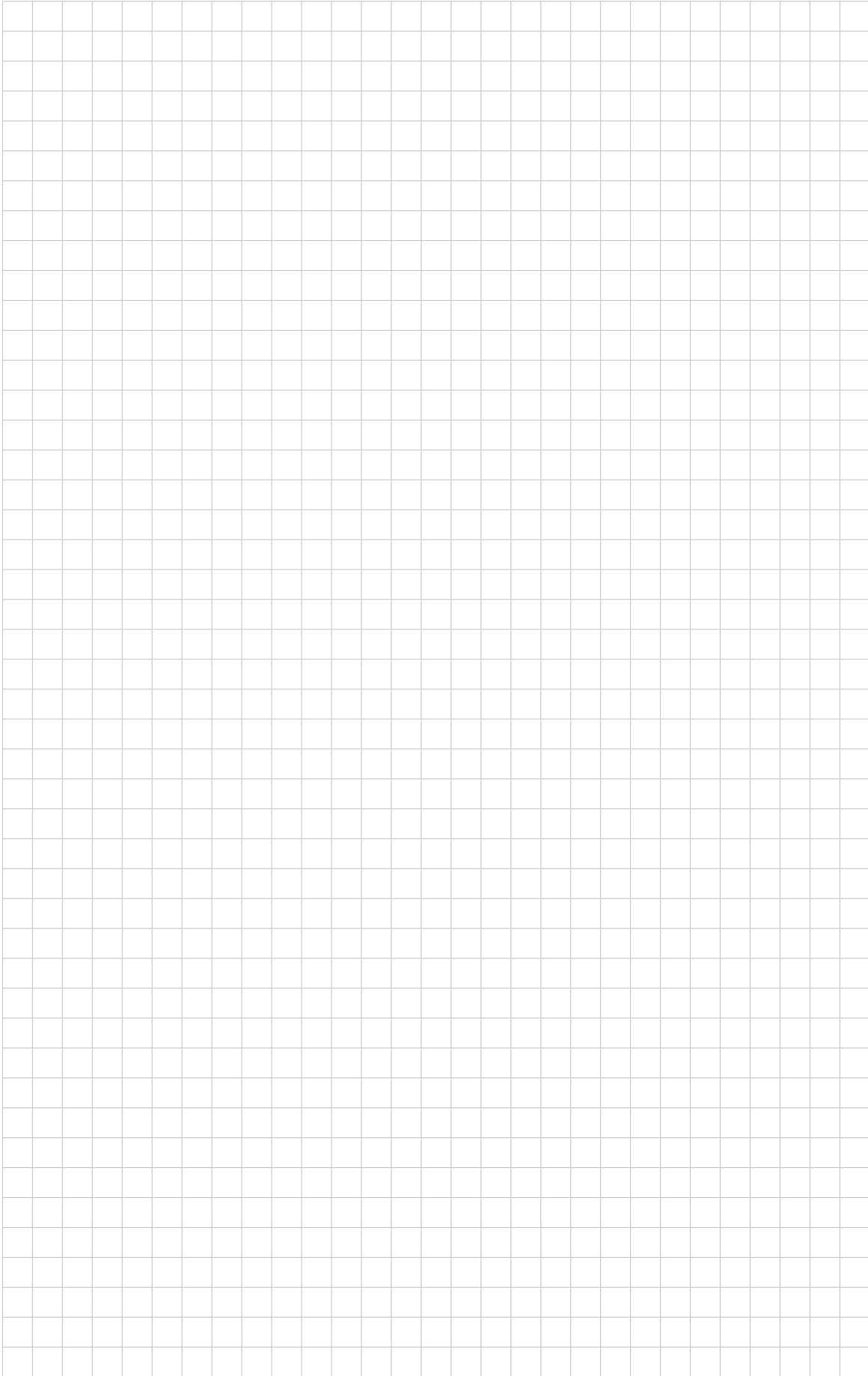

APEM

Switches & Pilot Lights

Control Boxes

Emergency Stop Switches

Enabling Switches

Safety Products

Explosion Proof

Terminal Blocks

Relays & Sockets

Circuit Protectors

Power Supplies

LED Illumination

Controllers

Operator Interfaces

Sensors

AUTO-ID

HE1B

HE2B

HE3B

HE5B

HE6B

HE2G

HE1G-L

Actuator w/ Plastic Holder

# Actuator with Plastic Holder

## HS5 series interlock switches detect the installation/removal of grip style enabling switches.

- The actuator with plastic holder for the HS5 series interlock switches can be installed onto the HE1G/HE1G-L/HE2G grip style enabling switches easily using the two mounting screws supplied with the actuator.
- Inserting the actuator on the grip style enabling switch into the entry slot of HS5D/HS5B/HS5E/HS5E-K interlock switch, the grip style enabling switch can be retained firmly in position.
- Using with HS5E/HS5E-K interlock switches prevent unauthorized removal of grip style enabling switches.
- Easy switching by removing/installing the grip style enabling switches can be achieved by designing the circuit to initiate automatic or manual operation when the interlock switch is installed or removed, respectively.

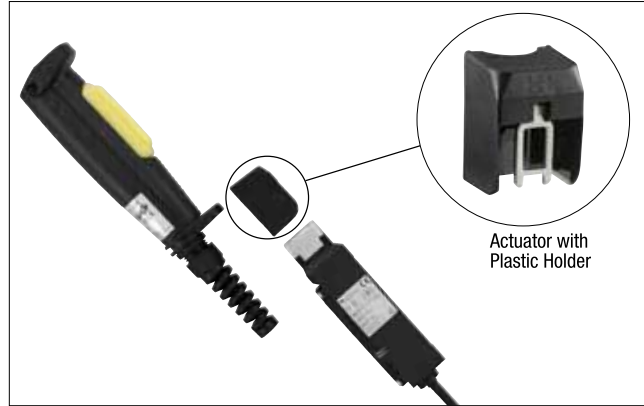

## Specifications

Description	Part No.
Actuator with plastic holder for HE1G/HE1G-L/HE2G	HE9Z-GP15

  

Applicable Model	HE1G/HE1G-L/HE2G Grip Style Enabling Switch HS5D/HS5B/HS5E/HS5E-K Interlock Switch
Mechanical Durability	10,000 operations
Weight (approx.)	30g

Note: Refer to the specifications of HE1G/HE1G-L/HE2G grip style enabling switches and HS5D/HS5L/HS5E/HS5E-K interlock switches.

## Dimensions

When used with an HE1G/HE1G-L and HS5D/HS5B

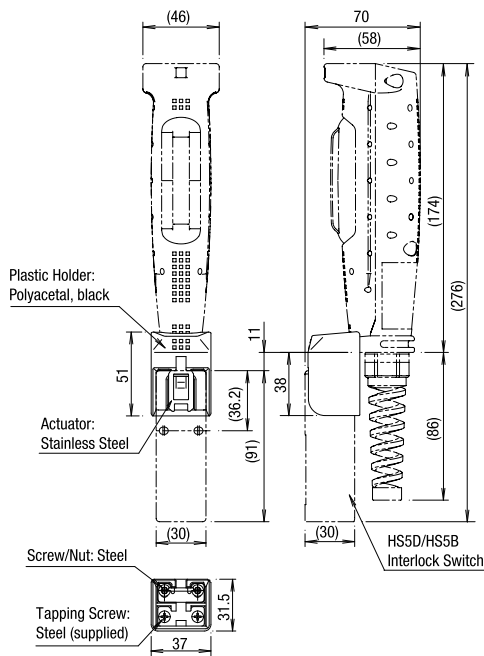

When used with an HE1G/HE1G-L and HS5E/HS5E-K

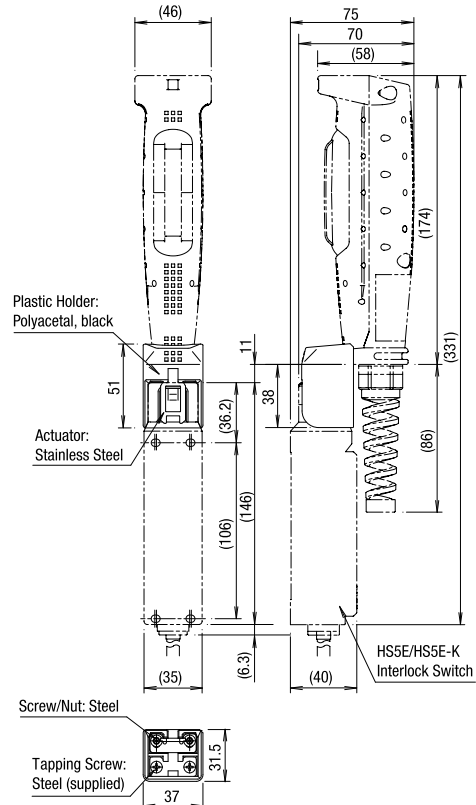

All dimensions in mm.

- APEM
- Switches & Pilot Lights
- Control Boxes
- Emergency Stop Switches
- Enabling Switches
- Safety Products
- Explosion Proof
- Terminal Blocks
- Relays & Sockets
- Circuit Protectors
- Power Supplies
- LED Illumination
- Controllers
- Operator Interfaces
- Sensors
- AUTO-ID

- HE1B
- HE2B
- HE3B
- HE5B
- HE6B
- HE2G
- HE1G-L
- Actuator w/ Plastic Holder

Instructions

Mounting

- ① The HE9Z-GP15 and the HE1G/HE1G-L are installed as shown in the following figure.

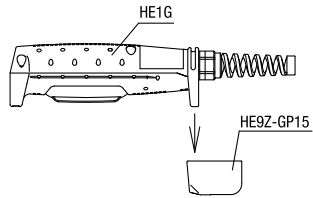

- ② Secure the actuator using the attached two screws in the direction of the arrow as shown in the following figure.

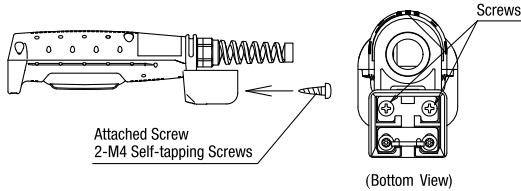

- Using the attached screws (M4 self-tapping screw × 2), secure the HE9Z-GP15 to the grip style enabling switch. Recommended tightening torque: 1.0 ±0.1 N·m. Do not use excessive force to tighten the HE9Z-GP15 onto the switch, otherwise the mounting holes will become deformed and the HE9Z-GP15 cannot be secured. Prevent the screws from loosening by applying epoxy. (Recommended: LOCTITE 425, ThreeBond 1401)

Precautions for Installation

- When using the HE9Z-GP15 for safety-related equipment in a control system, refer to safety standards and regulations in each country and region to make sure of correct operation. Also, perform a risk assessment to ensure safety before starting operation of the machine.
- Read the instruction sheets for both the grip style enabling switch and interlock switch to be used.
- Insert the HE9Z-GP15 in the direction shown in the following figure only. Do not insert from any other direction. Also, do not use the slot plug attached to the interlock switch.

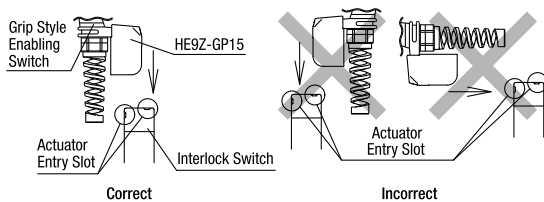

- See below for vertical installation. Do not install in any other direction. Also, make sure that the mounting surface is provided for the entire area of the grip style enabling switch, so that the switch does not tilt as shown below. Otherwise the HE9Z-GP15 actuator will be deformed.

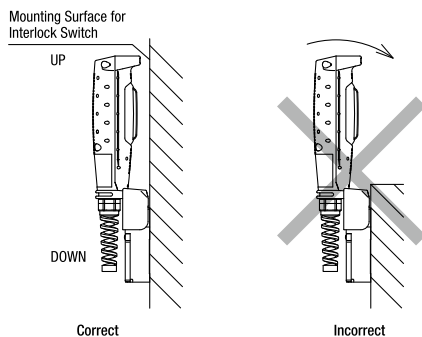

- Do not install the grip style enabling switch and the interlock switch in an area subjected to vibration. Excessive vibration may cause malfunction of the switch contacts of the grip style enabling switch. Also, exposure to vibration for a long period of time can cause scratching and deformation of plastic parts.
- When installing or removing the grip style enabling switch, do not use excessive force in any direction other than shown in the following figure. Otherwise the HE9Z-GP15 actuator can become deformed or damaged.

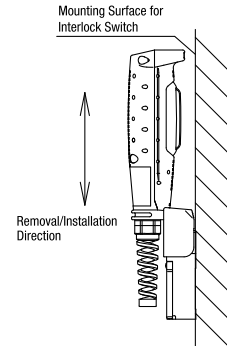

- Make sure that the HE9Z-GP15 actuator is inserted completely into the interlock switch. Avoid any foreign objects between the actuator and interlock switch as they may interfere with the plastic spring, resulting in possible damage to the actuator.

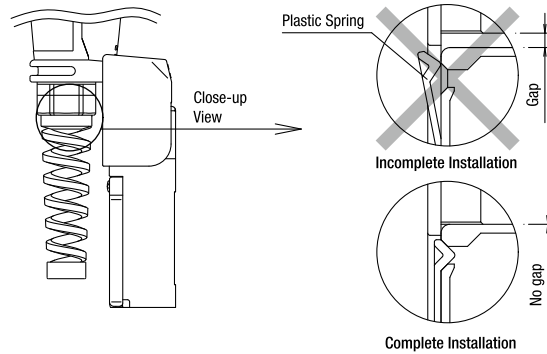

- When manually unlocking the HS5L interlock switch attached to the grip style enabling switch, bend the spiral part of the connector slightly to be able to access the manual unlock key.

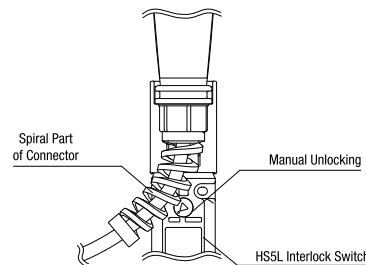

- Do not apply excessive shocks to the HE9Z-GP15 when attached to the interlock switch, otherwise the actuator may be removed from the interlock switch. Also excessive shocks may result in damage or failure of the interlock switch.
- When the plastic part of the HE9Z-GP15 or the actuator is damaged or deformed, stop using immediately.
- The HE9Z-GP15 is used for HE1G/HE1G-L/HE2G grip style enabling switch and HS5D/HS5B/HS5L/HS5E-K interlock switches only. Do not use the HE9Z-GP15 for other products.
- Do not modify or disassemble the HE9Z-GP15.

- APEM
- Switches & Pilot Lights
- Control Boxes
- Emergency Stop Switches
- Enabling Switches
- Safety Products
- Explosion Proof
- Terminal Blocks
- Relays & Sockets
- Circuit Protectors
- Power Supplies
- LED Illumination
- Controllers
- Operator Interfaces
- Sensors
- AUTO-ID
- HE1B
- HE2B
- HE3B
- HE5B
- HE6B
- HE2G
- HE1G-L
- Actuator w/ Plastic Holder

# Ordering Terms and Conditions

Thank you for using IDEC Products.

By purchasing products listed in our catalogs, datasheets, and the like (hereinafter referred to as "Catalogs") you agree to be bound by these terms and conditions. Please read and agree to the terms and conditions before placing your order.

## 1. Notes on contents of Catalogs

- (1) Rated values, performance values, and specification values of IDEC products listed in this Catalog are values acquired under respective conditions in independent testing, and do not guarantee values gained in combined conditions.  
Also, durability varies depending on the usage environment and usage conditions.
- (2) Reference data and reference values listed in Catalogs are for reference purposes only, and do not guarantee that the product will always operate appropriately in that range.
- (3) The specifications / appearance and accessories of IDEC products listed in Catalogs are subject to change or termination of sales without notice, for improvement or other reasons.
- (4) The content of Catalogs is subject to change without notice.

## 2. Note on applications

- (1) If using IDEC products in combination with other products, confirm the applicable laws / regulations and standards.  
Also, confirm that IDEC products are compatible with your systems, machines, devices, and the like by using under the actual conditions. IDEC shall bear no liability whatsoever regarding the compatibility with IDEC products.
- (2) The usage examples and application examples listed in Catalogs are for reference purposes only. Therefore, when introducing a product, confirm the performance and safety of the instruments, devices, and the like before use. Furthermore, regarding these examples, IDEC does not grant license to use IDEC products to you, and IDEC offers no warranties regarding the ownership of intellectual property rights or non-infringement upon the intellectual property rights of third parties.
- (3) When using IDEC products, be cautious when implementing the following.
  - i. Use of IDEC products with sufficient allowance for rating and performance
  - ii. Safety design, including redundant design and malfunction prevention design that prevents other danger and damage even in the event that an IDEC product fails
  - iii. Wiring and installation that ensures the IDEC product used in your system, machine, device, or the like can perform and function according to its specifications
- (4) Continuing to use an IDEC product even after the performance has deteriorated can result in abnormal heat, smoke, fires, and the like due to insulation deterioration or the like. Perform periodic maintenance for IDEC products and the systems, machines, devices, and the like in which they are used.
- (5) IDEC products are developed and manufactured as general-purpose products for general industrial products. They are not intended for use in the following applications, and in the event that you use an IDEC product for these applications, unless otherwise agreed upon between you and IDEC, IDEC shall provide no guarantees whatsoever regarding IDEC products.
  - i. Use in applications that require a high degree of safety, including nuclear power control equipment, transportation equipment (railroads / airplanes / ships / vehicles / vehicle instruments, etc.), equipment for use in outer space, elevating equipment, medical instruments, safety devices, or any other equipment, instruments, or the like that could endanger life or human health
  - ii. Use in applications that require a high degree of reliability, such as provision systems for gas / waterworks / electricity, etc., systems that operate continuously for 24 hours, and settlement systems
  - iii. Use in applications where the product may be handled or used deviating from the specifications or conditions / environment listed in the Catalogs, such as equipment used outdoors or applications in environments subject to chemical pollution or electromagnetic interference  
If you would like to use IDEC products in the above applications, be sure to consult with an IDEC sales representative.

## 3. Inspections

We ask that you implement inspections for IDEC products you purchase without delay, as well as thoroughly keep in mind management/maintenance regarding handling of the product before and during the inspection.

## 4. Warranty

### (1) Warranty period

The warranty period for IDEC products shall be one (1) year after purchase or delivery to the specified location. However, this shall not apply in cases where there is a different specification in the Catalogs or there is another agreement in place between you and IDEC.

### (2) Warranty scope

Should a failure occur in an IDEC product during the above warranty period for reasons attributable to IDEC, then IDEC shall replace or repair that product, free of charge, at the purchase location / delivery location of the product, or an IDEC service base. However, failures caused by the following reasons shall be deemed outside the scope of this warranty.

- i. The product was handled or used deviating from the conditions / environment listed in the Catalogs
- ii. The failure was caused by reasons other than an IDEC product
- iii. Modification or repair was performed by a party other than IDEC
- iv. The failure was caused by a software program of a party other than IDEC
- v. The product was used outside of its original purpose
- vi. Replacement of maintenance parts, installation of accessories, or the like was not performed properly in accordance with the user's manual and Catalogs
- vii. The failure could not have been predicted with the scientific and technical standards at the time when the product was shipped from IDEC
- viii. The failure was due to other causes not attributable to IDEC (including cases of force majeure such as natural disasters and other disasters)

Furthermore, the warranty described here refers to a warranty on the IDEC product as a unit, and damages induced by the failure of an IDEC product are excluded from this warranty.

## 5. Limitation of liability

The warranty listed in this Agreement is the full and complete warranty for IDEC products, and IDEC shall bear no liability whatsoever regarding special damages, indirect damages, incidental damages, or passive damages that occurred due to an IDEC product.

## 6. Service scope

The prices of IDEC products do not include the cost of services, such as dispatching technicians. Therefore, separate fees are required in the following cases.

- (1) Instructions for installation / adjustment and accompaniment at test operation (including creating application software and testing operation, etc.)
- (2) Maintenance inspections, adjustments, and repairs
- (3) Technical instructions and technical training
- (4) Product tests or inspections specified by you

The above content assumes transactions and usage within your region. Please consult with an IDEC sales representative regarding transactions and usage outside of your region. Also, IDEC provides no guarantees whatsoever regarding IDEC products sold outside your region.

# IDEC CORPORATION

**Head Office** 6-64, Nishi-Miyahara-2-Chome, Yodogawa-ku, Osaka 532-0004, Japan

**USA** IDEC Corporation  
**EMEA** APEM SAS

**Singapore** IDEC Izumi Asia Pte. Ltd.  
**Thailand** IDEC Asia (Thailand) Co., Ltd.  
**India** IDEC Controls India Private Ltd.

**China** IDEC (Shanghai) Corporation  
IDEC Izumi (H.K.) Co., Ltd.  
**Taiwan** IDEC Taiwan Corporation

**Japan** IDEC Corporation

 [www.idec.com](http://www.idec.com)

Specifications and other descriptions in this brochure are subject to change without notice.

2023 IDEC Corporation, All Rights Reserved.

