

CAT #'S	"L"	"H"	"W"
GPL-1	1.875	2.665	1.563
GPL-2	1.875	2.665	1.563
GPL-3	1.875	2.665	1.563
GPL-4	2.250	2.875	1.563
GPL-5	2.250	2.875	1.563
GPL-6	2.250	2.875	1.563
GPL-7	2.250	2.875	1.563
GPL-8	2.625	3.265	1.563
GPL-9	2.625	3.265	1.563
GPL-10	2.625	3.265	1.563
GPL-12	2.625	3.265	1.563
GPL-14	2.750	3.540	1.563
GPL-15	2.750	3.540	1.563
GPL-16	2.750	3.540	1.563
GPL-17	2.750	3.540	1.563
GPL-20	3.00	3.665	1.563
GPL-21	3.00	3.665	1.563
GPL-22	3.00	3.665	1.563
GPL-23	3.00	3.665	1.563
GPL-26	3.250	4.165	1.563
GPL-27	3.250	4.165	1.563
GPL-28	3.250	4.165	1.563
GPL-29	3.250	4.165	1.563
GPL-32	3.625	4.665	1.563
GPL-33	3.625	4.665	1.563
GPL-34	3.625	4.665	1.563
GPL-35	3.625	4.665	1.563
GPL-38	4.250	5.165	1.600
GPL-39	4.250	5.165	1.600
GPL-40	4.250	5.165	1.600
GPL-41	4.250	5.165	1.600
GPL-44	4.750	5.790	1.600
GPL-45	4.750	5.790	1.600
GPL-46	4.750	5.790	1.600
GPL-47	4.750	5.790	1.600
GPL-50	5.250	6.790	1.600
GPL-51	5.250	6.790	1.600
GPL-52	5.250	6.790	1.600
GPL-53	5.250	6.790	1.600
GPL-56	5.875	7.040	1.600
GPL-57	5.875	7.040	1.600
GPL-58	5.875	7.040	1.600
GPL-59	5.875	7.040	1.600
GPL-68	7.00	8.665	1.563
GPL-69	7.00	8.665	1.563
GPL-70	7.00	8.665	1.563
GPL-71	7.00	8.665	1.563
GPL-75	8.00	9.165	1.563
GPL-76	8.00	9.165	1.563
GPL-77	8.00	9.165	1.563

MASS:  
CAT. NO.:

TOLERANCES-UNLESS OTHERWISE SPECIFIED  
2 PL. DEC. ±.015 TRUE C.L. ±.015  
3 PL. DEC. ±.015 ANGLES ±1

DWG. NO.  
**M3050**  
SHEET 10F 1



DRAWN BY: CLH SCALE: 1:1  
DATE: 1/10/2013 SIZE: A

REV.	DESCRIPTION
A	

CAT #: SEE CHART

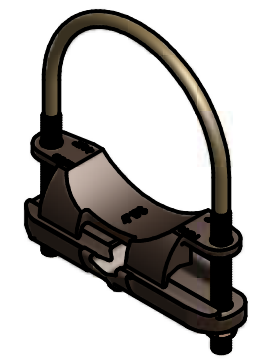
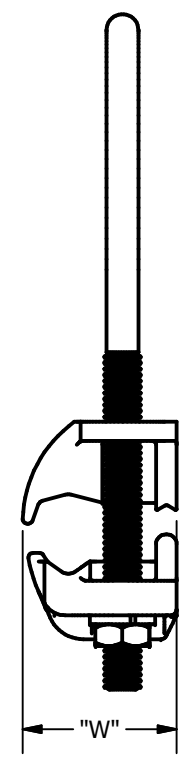
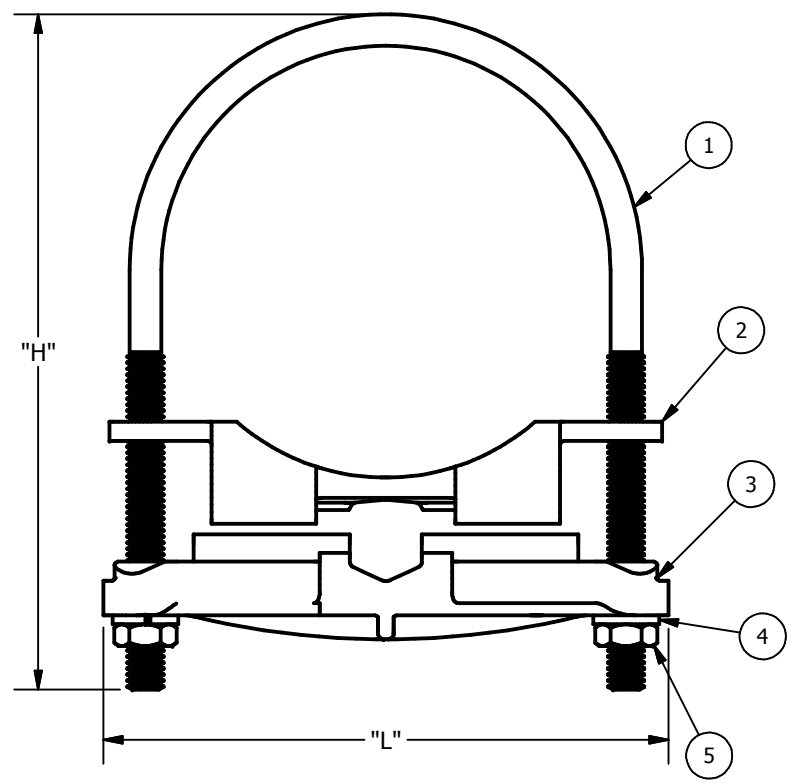

SCALE 1 / 4