

# Model 5A

## Current Transformer Window Diameter 1.56"

### Application

Ammeters and wattmeters.

### Frequency

50-400 Hz.

### Insulation Level

600 Volt, 10 kV BIL full wave.

Terminal are brass studs No. 8-32 with one flatwasher, lockwasher and regular nut.

Flexible leads are UL 1015, 105 °C, CSA approved, #16 AWG, 24" long. Non-standard, lead length can be specified.

Order mounting bracket kit 0221B00180 separately for Model 5ASHT.

Model 5ASHT and model 5ASFT also available as 5ASHL and 5ASFL with leads.

Approximate weight 1 lb.



Model 5ASHT

Model 5ARL

#### REGULATORY AGENCY APPROVALS



Manufactured to meet the requirements of ANSI/IEEE C57.13. Classified by U.L. in accordance with IEC 44-1

## Model 5A

Catalog Number	Current Ratio	V.A. ± 1% Class	ANSI Metering Class at 60 Hz					Secondary Winding Resistance (Ω @ 75 °C)	Continuous Thermal Rating Factor	
			B0.1	B0.2	B0.5	B0.9	B1.8		@ 30 °C	@ 55 °C
5A**–500	50:5	1.0	4.8	—	—	—	—	0.009	2.0	2.0
5A**–750	75:5	1.0	2.4	4.8	—	—	—	0.010	2.0	2.0
5A**–101	100:5	1.0	1.2	2.4	—	—	—	0.012	2.0	2.0
5A**–151	150:5	5.0	0.6	1.2	2.4	4.8	—	0.019	2.0	2.0
5A**–201	200:5	5.0	0.6	0.6	1.2	2.4	4.8	0.024	2.0	2.0
5A**–251	250:5	12.5	0.6	0.6	1.2	2.4	2.4	0.033	2.0	1.5
5A**–301	300:5	15.0	0.3	0.3	0.6	1.2	2.4	0.040	2.0	1.5
5A**–401	400:5	20.0	0.3	0.3	0.6	1.2	1.2	0.091	1.5	1.0
5A**–501	500:5	25.0	0.3	0.3	0.6	0.6	1.2	0.105	1.33	0.8
5A**–601	600:5	30.0	0.3	0.3	0.6	0.6	1.2	0.158	1.0	0.8
5A**–751	750:5	30.0	0.3	0.3	0.6	0.6	0.6	0.147	1.0	0.8
5A**–801	800:5	30.0	0.3	0.3	0.6	0.6	0.6	0.156	1.0	0.8
5A**–102	1,000:5	35.0	0.3	0.3	0.3	0.6	0.6	0.196	1.0	0.8
5A**–122	1,200:5	40.0	0.3	0.3	0.3	0.3	0.6	0.291	1.0	0.6

\*\*Note: When ordering, prefix Cat No. with model designation required i.e. 5ASHT-501, 5ARL 501, etc.



Model 5A

Model 5ASFT

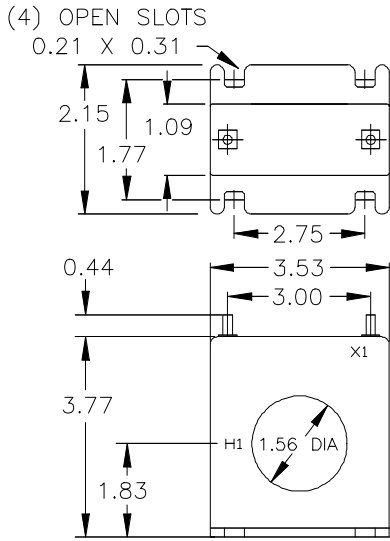

Model 5ASHT

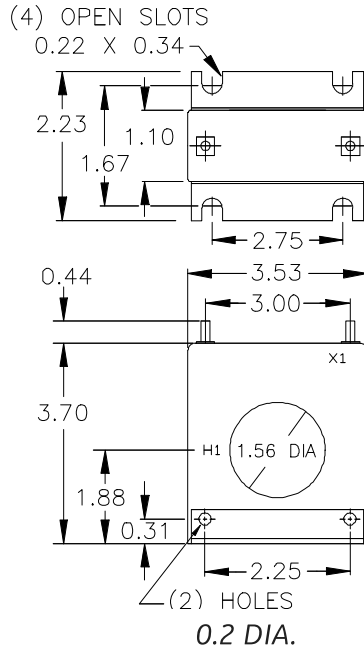

Model 5ARL

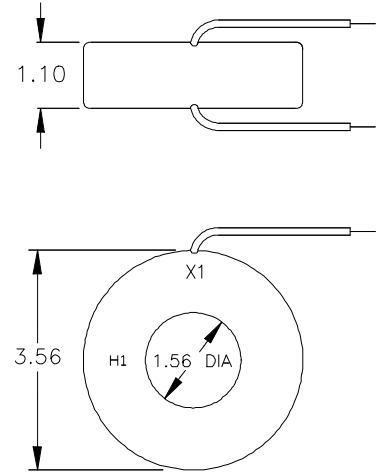

Grid-AIS-L4-ITL\_Model\_5A-1214-2017\_05-EN. © Copyright 2017. General Electric Company and Instrument Transformers LLC reserve the right to change specifications of described products at any time without notice and without obligation to notify any person of such changes.

