



V248 Series Three-Way Pressure-Actuated Water-Regulating Valves for High-Pressure Refrigerants

Description

The V248 Series Three-Way Pressure-Actuated Water-Regulating Valves for High-Pressure Refrigerants regulate water flow and control refrigerant head pressure in systems with single or multiple water-cooled condensers.

V248 valves have an adjustable opening point in a refrigerant pressure range of 200 to 400 psi (13.8 to 27.6 bar). V248 valves are available in 1/2 in. through 1-1/2 in. size for use with standard, non-corrosive, high-pressure refrigerants.

Maritime models, which have nickel copper (Monel®) internal parts, are available for applications where the media may be corrosive to the internal parts.

Refer to the *V248 Series 3-Way Pressure-Actuated Water-Regulating Valves for High-Pressure Refrigerants Product Bulletin (LIT-12011515)* for important product application information.

Features

- no close fitting or sliding parts in water passages
- accessible range spring
- take-apart construction
- pressure-balanced design
- corrosion-resistant material for internal parts

Repair Information

If the V248 Series Three-Way Pressure-Actuated Water-Regulating Valves for High-Pressure Refrigerants fails to operate within its specifications, refer to the *V248 Series 3-Way Pressure-Actuated Water-Regulating Valves for High-Pressure Refrigerants Product Bulletin (LIT-12011515)* for a list of repair parts available.



V248 Screw Connection Valve

Selection Charts

North American Standard Production Models - Range 200 to 400 psi

Product Code Number	Construction	Valve Size and Connection	Element Style	Shipping Weight, lb (kg)
V248GB1-001C	Direct Acting, Commercial	1/2 in. NPT Screw	Style 5	5.0 (2.3)
V248GC1-001C	Direct Acting, Commercial	3/4 in. NPT Screw	Style 5	6.5 (3.0)
V248GD1-001C	Direct Acting, Commercial	1 in. NPT Screw	Style 5	12.0 (5.4)
V248GE1-001C	Direct Acting, Commercial	1-1/4 in. NPT Screw	Style 5	16.0 (7.2)
V248GF1-001C	Direct Acting, Commercial	1-1/2 in. NPT Screw	Style 5	25.0 (11.3)
V248GK1-001C	Direct Acting, Commercial	3/4 in. Union Sweat	Style 5	7.0 (3.2)
V248GL1-001C	Direct Acting, Commercial	1 in. Union Sweat	Style 5	12.0 (5.4)
V248GM1-001C	Direct Acting, Commercial	1-1/4 in. Union Sweat	Style 5	13.7 (6.2)

European Standard Production Models - Range 13.8 to 27.8 bar

Product Code Number	Construction	Valve Size and Connection	Element Style	Shipping Weight, lb (kg)
V248GB1B001C	Direct Acting, Commercial	1/2 in. BSPT Screw, ISO 7	Style 5	5.0 (2.3)
V248GC1B001C	Direct Acting, Commercial	3/4 in. BSPT Screw, ISO 7	Style 5	6.5 (3.0)
V248GD1B001C	Direct Acting, Commercial	1 in. BSPT Screw, ISO 7	Style 5	12.1 (5.5)
V248GE1B001C	Direct Acting, Commercial	1-1/4 in. BSPT Screw, ISO 7	Style 5	16.0 (7.2)
V248GF1B001C	Direct Acting, Commercial	1-1/2 in. BSPT Screw, ISO 7	Style 5	25.0 (11.3)
V248HC1B001C	Direct Acting, Maritime	3/4 in. BSPP Screw, ISO 228	Style 5	6.5 (3.0)

The performance specifications are nominal and conform to acceptable industry standards. For applications at conditions beyond these specifications, consult the Johnson Controls, Inc. shall not be liable for damages resulting from misapplication or misuse of its products. © 2015 Johnson Controls, Inc.



V248 Series Three-Way Pressure-Actuated Water-Regulating Valves for High-Pressure Refrigerants (Continued)

Applications

Each application is unique and requires specific engineering data to properly size and design a system to fulfill the appropriate requirements. Typically, a valve is replaced with another valve of the same size in a properly sized and engineered system. In North America, contact Johnson Controls/PENN® Refrigeration Application Engineering at 1-800-275-5676 to obtain specific engineering data. In other areas, contact the local Johnson Controls® sales office to obtain specific engineering data.

To make a rough field estimate of the size of valve for an application, find the valve size needed by locating a point on a flow chart that satisfies these requirements:

- water flow required by the condenser (**Flow**)
- refrigerant head pressure rise (**P_{RISE}**)
- available water pressure (**P_{AVAIL}**)

Follow these steps, and use the information obtained to locate a point on one of the flowcharts that satisfies all three steps.

1. Take the water flow required by the condenser (**Flow**) from information provided by the manufacturer of the condensing unit. If the manufacturer's information is unavailable, use the following information to make a rough approximation of water flow in gallons per minute (gpm) [cubic meters per hour (m³/hr)]:
 - System Capacity (**Tons of Refrigeration**)
 - Outlet Water Temperature (**Temp. _{Outlet}**)
 - Inlet Water Temperature (**Temp. _{Inlet}**)

Calculate the flow using the following formula:

$$\text{Flow} = \frac{\text{Tons of Refrigeration} \times 30}{(\text{Temp.}_{\text{Outlet}} - \text{Temp.}_{\text{Inlet}})}$$

Flow Required

Note: If the outlet temperature is unknown, assume it to be 10F° (6C°) above the inlet temperature.

2. Determine refrigerant head pressure rise above the valve opening point (**P_{RISE}**) using the following steps:
 - a. The **Valve Closing Pressure (P_{CLOSE})** is equal to the refrigerant pressure at the highest ambient temperature the refrigeration equipment experiences in the Off cycle. Use a Pressure-Temperature Chart for the refrigerant selected to find this pressure.
 - b. To approximate the **Valve Opening Pressure (P_{OPEN})**, add about 10 psig (0.7 bar) to the Valve Closing Pressure.

$$P_{\text{OPEN}} = P_{\text{CLOSE}} + 10 \text{ psi (0.7 bar)}$$

Valve Opening Pressure

- c. From the Pressure-Temperature Chart for the refrigerant selected, read the **Refrigerant Condensing Pressure (P_{COND})** (operating head pressure) corresponding to the selected condensing temperature.
- d. Subtract the Valve Opening Pressure from the Refrigerant Condensing Pressure. This gives the head pressure rise.

$$P_{\text{RISE}} = P_{\text{COND}} - P_{\text{OPEN}}$$

Refrigerant Head Pressure Rise

3. Determine the available water pressure to the valve (**P_{AVAIL}**) using the following steps. This the actual water pressure available to force water through the valve.
 - a. Determine the minimum inlet pressure (**P_{IN}**). This is the water pressure from city water mains, pumps, or other sources.
 - b. Pressure drop through condenser (**ΔP_{COND}**) is the difference in water pressure between the condenser inlet and the condenser outlet. Obtain this information from the condenser manufacturer.
 - c. Estimate or calculate the pressure drop through all associated piping (**P_{LOSS}**).
 - d. Subtract the **ΔP_{COND}** and **P_{LOSS}** from **P_{IN}**. The result is **P_{AVAIL}**.

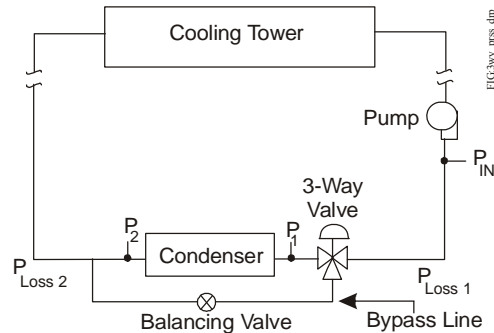

$$\Delta P_{\text{COND}} = P_1 - P_2$$

$$P_{\text{LOSS}} = P_{\text{Loss 1}} + P_{\text{Loss 2}} + \dots$$

$$P_{\text{AVAIL}} = P_{\text{IN}} - (\Delta P_{\text{COND}} + P_{\text{LOSS}})$$

Available Water Pressure

4. Select the proper valve size from the flowcharts by locating a point on a chart that satisfies the flow, the head pressure rise above opening point, and the pressure drop across the valve.

Metric Conversions

Use these equations to convert between U.S. and S.I. units.

- 1 dm³/s = 3.6 m³/h = 15.9 U.S. gal. /min. = 13.2 U.K. gal. /min.
- 1 bar = 100 kPa = 0.1 MPa = 1.02 kg/cm² = 0.987 atm = 14.5 psig



V248 Series Three-Way Pressure-Actuated Water-Regulating Valves for High-Pressure Refrigerants (Continued)

V248 Flowcharts

The maximum recommended differential water pressure across a valve is 20 psig (1.4 bar).

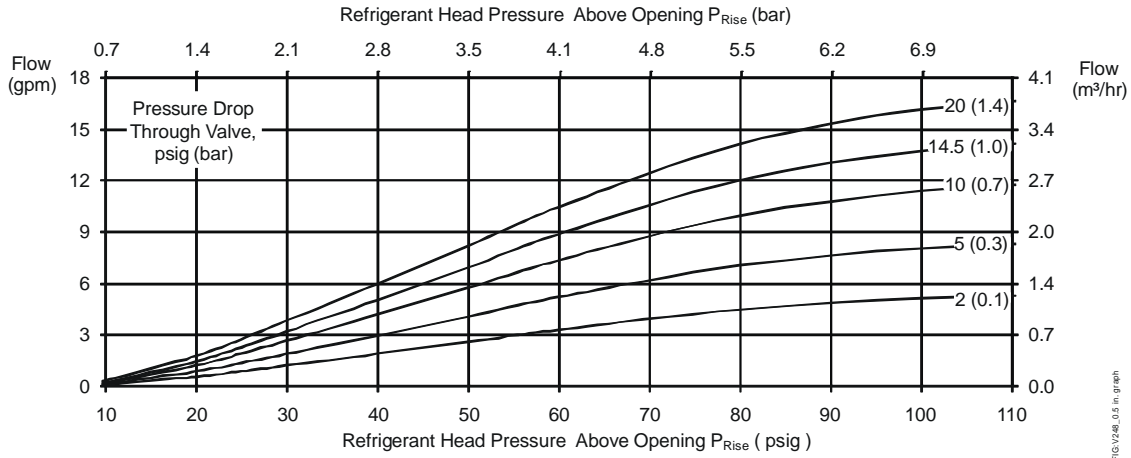

1/2 in. Direct Acting Valve Flowchart

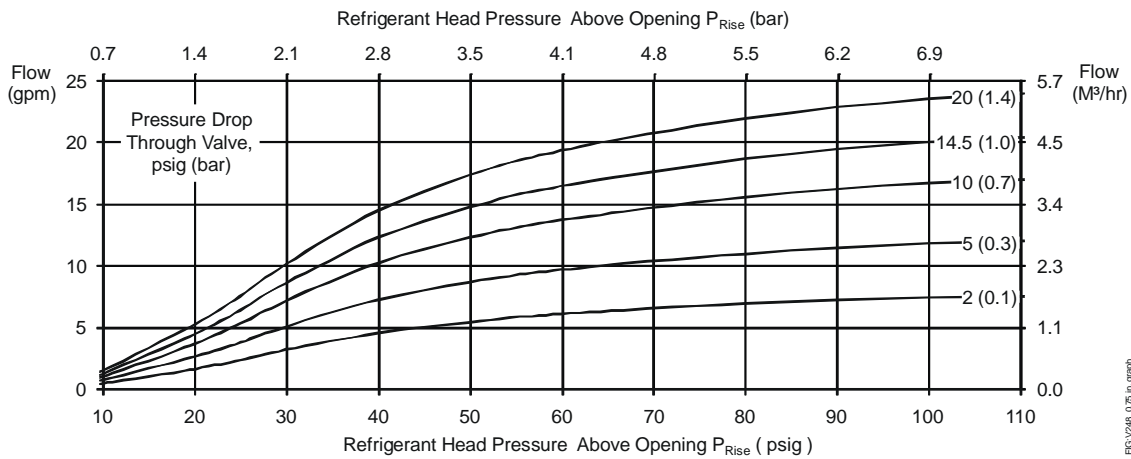

3/4 in. Direct Acting Valve Flowchart

The performance specifications are nominal and conform to acceptable industry standards. For applications at conditions beyond these specifications, consult th Johnson Controls, Inc. shall not be liable for damages resulting from misapplication or misuse of its products. © 2015 Johnson Controls, Inc.



V248 Series Three-Way Pressure-Actuated Water-Regulating Valves for High-Pressure Refrigerants (Continued)

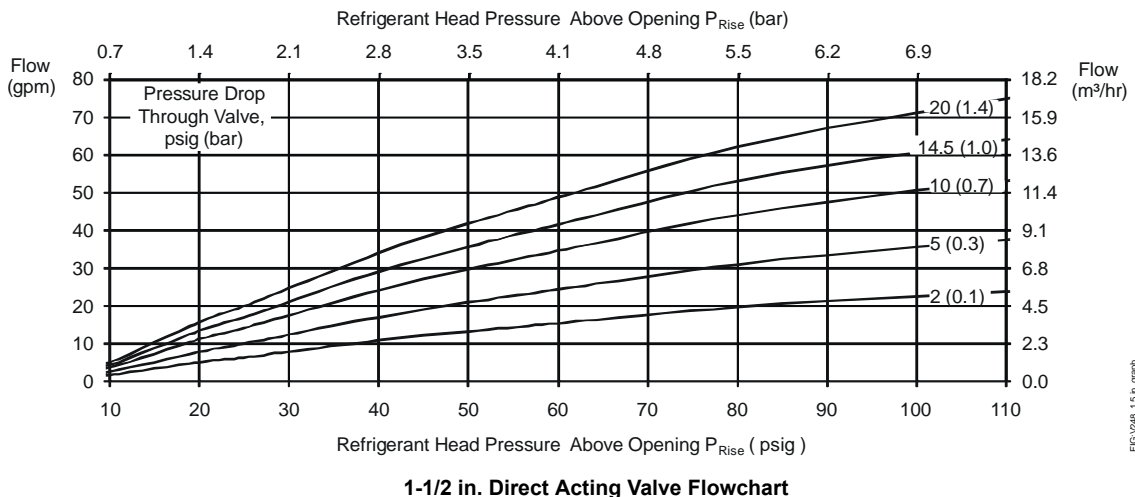
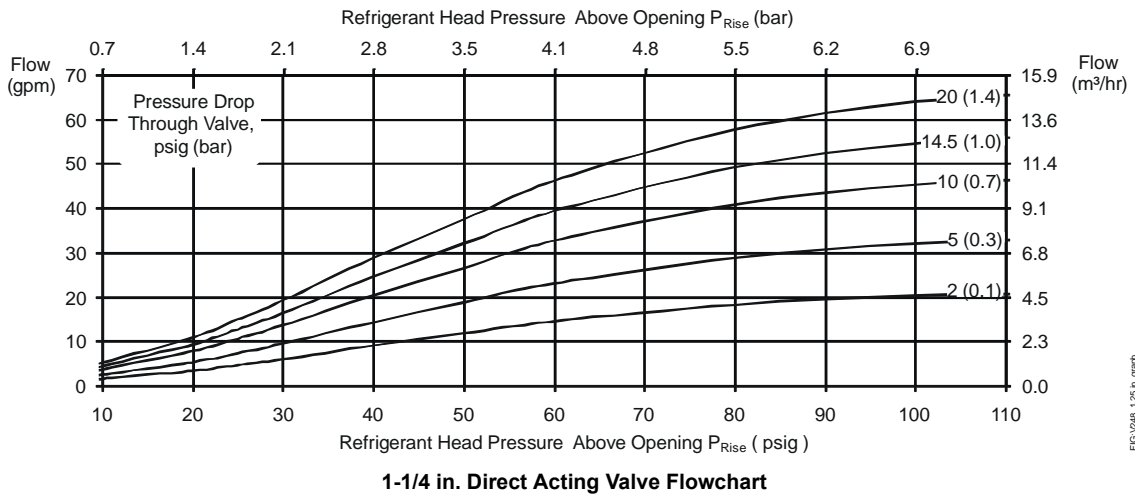
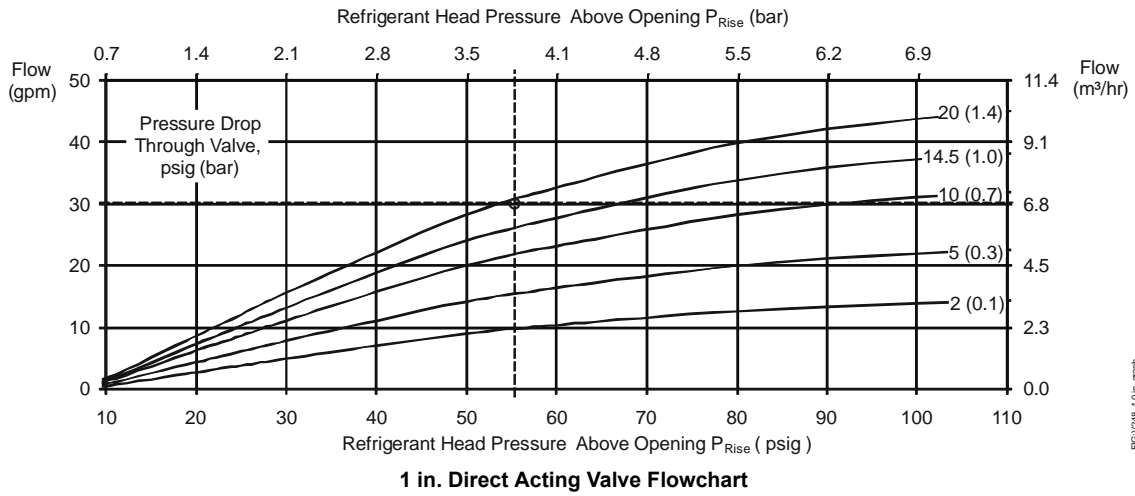

The performance specifications are nominal and conform to acceptable industry standards. For applications at conditions beyond these specifications, consult the Johnson Controls, Inc. shall not be liable for damages resulting from misapplication or misuse of its products. © 2015 Johnson Controls, Inc.

V248 Series Three-Way Pressure-Actuated Water-Regulating Valves for High-Pressure Refrigerants (Continued)

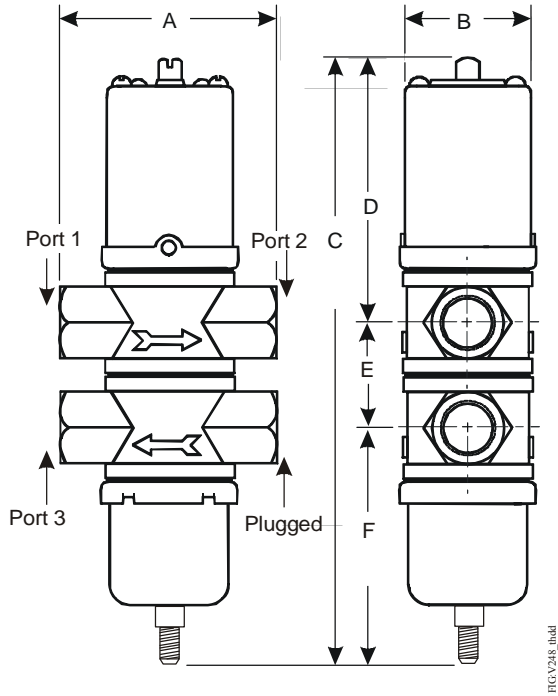

V248 1/2 in. Through 1-1/4 in. Screw Connection Valves Dimensions

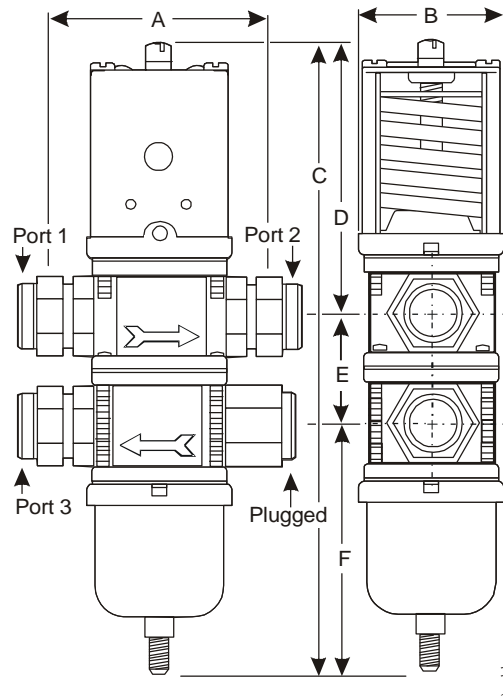

V248 Union Sweat Connection Valves Dimensions

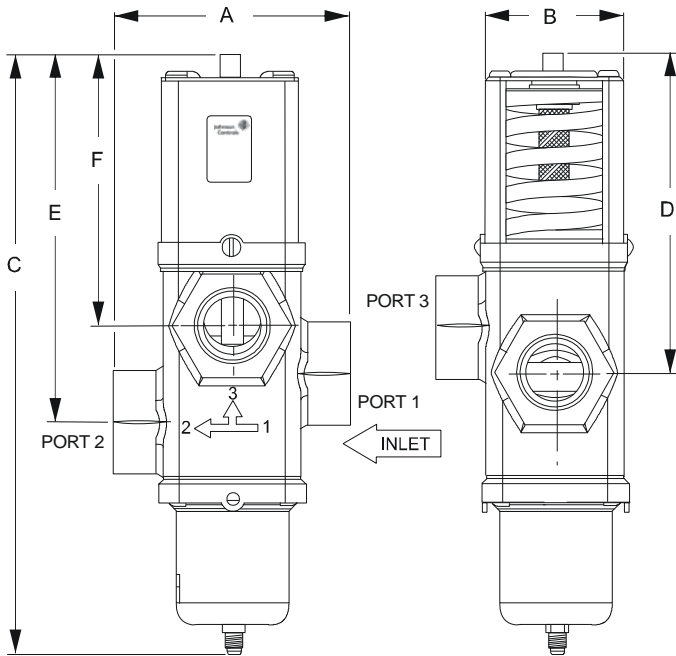

V248 1-1/2 in. Screw Connection Valves Dimensions

The performance specifications are nominal and conform to acceptable industry standards. For applications at conditions beyond these specifications, consult the Johnson Controls, Inc. shall not be liable for damages resulting from misapplication or misuse of its products. © 2015 Johnson Controls, Inc.



Valves and Valve Accessories

V248 Series Three-Way Pressure-Actuated Water-Regulating Valves for High-Pressure Refrigerants (Continued)

V248 1/2 in. Through 1-1/4 in. Screw Connection Valves Dimensions

Valve Size	Dimensions in Inches (Millimeters)					
	A	B	C	D	E	F
1/2 in.	3-1/16 (78)	2 (51)	8-11/16 (220)	3-13/16 (96)	1-1/2 (38)	3-3/8 (86)
3/4 in.	3-3/8 (86)	2-3/16 (55)	9-3/4 (248)	4-3/16 (106)	1-3/4 (44)	3-13/16 (98)
1 in.	4-3/4 (121)	2-13/16 (71)	12-1/2 (318)	5-15/16 (151)	2-1/16 (52)	4-1/2 (114)
1-1/4 in.	4-3/4 (121)	2-13/16 (71)	13-1/4 (336)	6-1/8 (156)	2-3/8 (60)	4-3/4 (121)

V248 Union Sweat Connection Valves Dimensions

Valve Size	Dimensions in Inches (Millimeters)					
	A	B	C	D	E	F
3/4 in.	3-3/8 (86)	2-3/16 (55)	9-3/4 (248)	4-3/16 (106)	1-3/4 (44)	3-13/16 (98)
1 in.	4-3/4 (121)	2-13/16 (71)	12-1/2 (318)	5-15/16 (151)	2-1/16 (52)	4-1/2 (114)
1-1/4 in.	4-3/4 (121)	2-13/16 (71)	13-1/4 (336)	6-1/8 (156)	2-3/8 (60)	4-3/4 (121)

V248 1-1/2 in. Screw Connection Valves Dimensions

Valve Size	Dimensions in Inches (Millimeters)					
	A	B	C	D	E	F
1-1/2 in.	6 (152)	3-1/2 (89)	15-1/4 (382)	8 (203)	9-5/16 (237)	6-7/8 (175)

The performance specifications are nominal and conform to acceptable industry standards. For applications at conditions beyond these specifications, consult the Johnson Controls, Inc. shall not be liable for damages resulting from misapplication or misuse of its products. © 2015 Johnson Controls, Inc.



V248 Series Three-Way Pressure-Actuated Water-Regulating Valves for High-Pressure Refrigerants (Continued)

Materials

North American V248 Materials

Nominal Valve Size:		3/8 in. to 3/4 in. (Commercial)	1 in. to 1-1/2 in. (Commercial)	Maritime (All Sizes)
Material				
Body		Cast brass	Cast iron/rust resisting finish	Cast bronze
Seat		Aluminum bronze	Aluminum bronze	Monel
Disc		BUNA-N	BUNA-N	BUNA-N
Disc Cup		Brass	Brass	Monel
Disc Stud		Brass	Brass	Monel
Stem/Extension Sleeve		Brass	Brass	Monel
Diaphragms		Nylon reinforced BUNA-N	Nylon reinforced BUNA-N	Nylon reinforced BUNA-N
Refrigerant Contact				
Pressure Element	Cup	300 Series stainless steel	300 Series stainless steel	300 Series stainless steel
	Bellows	300 Series stainless steel	300 Series stainless steel	300 Series stainless steel
	Bellows Ring	Steel/nickel plated	Steel/nickel plated	Steel/nickel plated

European V248 Materials

Nominal Valve Size:		3/8 in. to 3/4 in. (Commercial)	1 in. to 1-1/2 in. (Commercial)	Maritime (All Sizes)
Material				
Body		Hot forged brass	Cast iron/rust resisting finish	Cast bronze
Seat		Aluminum bronze	Aluminum bronze	Monel
Disc		BUNA-N	BUNA-N	BUNA-N
Disc Cup		Brass	Brass	Monel
Disc Stud		Brass	Brass	Monel
Stem/Extension Sleeve		Brass	Brass	Monel
Diaphragms		Nylon reinforced BUNA-N	Nylon reinforced BUNA-N	Nylon reinforced BUNA-N
Refrigerant Contact				
Pressure Element	Cup	300 Series stainless steel	300 Series stainless steel	300 Series stainless steel
	Bellows	300 Series stainless steel	300 Series stainless steel	300 Series stainless steel
	Bellows Ring	Steel/nickel plated	Steel/nickel plated	Steel/nickel plated

Technical Specifications

V248 Series Pressure-Actuated Water-Regulating Valves for High-Pressure Refrigerants	
Maximum Working Pressure	630 psig (43.4 bar)
Factory-Set Opening Point (Port 1 to Port 2)	275 psig (19.0 bar)
Opening Point Adjustment Range (Port 1 to Port 2)	200 to 400 psi (13.8 to 27.6 bar)
Throttling Range	120 psi (8.3 bar) for 1/2 in. size 100 psi (6.9 bar) for 3/4 in., 1 in., and 1-1/4 in. sizes 140 psi (9.6 bar) for 1-1/2 in. size
Media	150 psig (10.3 bar) maximum, -4°F to 170°F (-20°C to 77°C) glycol/water or liquids with low freezing points that are compatible with valve materials

The performance specifications are nominal and conform to acceptable industry standards. For applications at conditions beyond these specifications, consult the Johnson Controls, Inc. shall not be liable for damages resulting from misapplication or misuse of its products. © 2015 Johnson Controls, Inc.