

## MODEL DESCRIPTION

Model	Power
4683-TTM-1F	115V AC $\pm 10\%$
4683-TTM-2F	230V AC $\pm 10\%$
4683-TTM-3F	24VAC $\pm 10\%$

These devices are "rugged" RS-485 network repeaters used for isolating network signals and extending communication distances. Model 4683-TTM-xF units are similar to the Acromag Model 4SCR-TTM-x models, but add field-selectable, End-Of-Line (EOL) network terminations on board for both the A and B sides, are UL/cUL approved, and work at higher baud rates.

Operation is transparent to all other network devices and no handshaking is required. Up to 32 RS-485 devices can be driven. These repeaters are enclosed in a rugged aluminum enclosure and come ready to mount on any base plate, or can be installed into a NEMA enclosure for harsh environments.

Installation is as simple as mounting, setting the baud rate, connecting and terminating the network, and connecting power.

## FEATURES

- Designed for use with Johnson Controls N2 or BACnet MS/TP bus.
- No handshaking & No extra control lines required.
- Full I/O signal isolation.
- Supports baud rates of 600, 1200, 2400, 4800, 9600, 19.2K, 38.4K, and 76.8K, switch-selectable.
- Field-selectable, End-of-Line (EOL) network terminators on both the A (input) and B (output) sides.
- Transient protection installed to help protect connected devices from destructive noise spikes and line transients.
- Status LED's indicate transmission direction, RS-485 bus fault conditions, and power.
- 115VAC, 230VAC, and 24VAC models supported (no separate transformers are required for 24VAC models).

## OPERATION

The Model 4683-TTM-xF network repeaters are used to isolate and boost RS485 signals and extend network distance. Each repeater will permit the addition of up to another 32 devices to a network, and extend the communication distance another 4000 feet.

The repeater has two "sides" referred to as side A and side B. Side A typically connects to the network towards the host (input side). Side B connects to the extended network (output side). Functionally, sides A and B are equivalent. Transient signal protection is provided on both RS-485 sides. When both RS-485 lines are idle, each side is in the receive mode. When a one to zero transition is detected (signifying a start bit) on either side, the opposite side's transmitter is enabled (half-duplex). The transmitter stays enabled for one character's time (based on the baud rate switch setting). The character received is then passed through.

The repeater receives AC power through a three-screw terminal strip. Input power is fused and isolated. Model 4683-TTM-1F units require 115VAC, 4683-TTM-2F units require 230VAC, and 4683-TTM-3F units require 24VAC.

## COMMUNICATION SPECIFICATIONS

**Baud Rates:** DIP switch settings on unit for 600, 1200, 2400, 4800, 9600, 19.2K, 38.4K, & 76.8K baud rates. Only one switch must be closed according to baud rate required for proper operation.

**RS-485 Bus Loading:** One unit load equivalent.

**RS-485 Bus Drive:** Complete RS-485 compliance for up to 32 unit loads (31 unit loads if a repeater is used).

**End-of-Line Termination Network:** Refer to Figure 1. The EOL termination network is individually selected for both the A and B sides by a pair of shorting clips. The A side (input) is controlled by jumpers J1 & J2. The B side (output) is controlled by jumpers J3 & J4.

The EOL network termination is enabled for the A side or the B side when the associated pair of jumpers are positioned over pins 1 and 2. The EOL termination is disabled (removed from circuit) when the pair of jumpers are positioned over pins 2 and 3.

**Duplex:** Half duplex only.

**Data Format:** Ten bits typical (1 start bit, 8 data bits, and 1 stop bit). Other formats are supported.

**Status Indicators:** Red power LED; red RS-485 bus fault LED's, side A & B; green transmit LED's, A-to-B & B-to-A.

## PHYSICAL SPECIFICATIONS

**Operating Temperature:** -25°C to 70°C (-13°F to 158°F).

**Relative Humidity (RH):** 10 to 95% RH (non-condensing), up to 40° C (104° F).

**Power:** 115VAC  $\pm 10\%$ , 50/60Hz, 0.05A (Model 4683-TTM-1F); 230VAC  $\pm 10\%$ , 50/60Hz, 0.03A (Model 4683-TTM-2F); 24VAC  $\pm 10\%$ , 50/60Hz, 0.18A (Model 4683-TTM-3F).

**Power Line Fuse:** 0.5A, 250V, 3AG type. Refer to Figure 1 for fuse location.

**Isolation:** Unit includes galvanic and optical isolation between RS-485 side A, RS-485 side B, AC power, and chassis ground. Common mode voltages of up to 250Vrms, or 354V DC (withstands a 1500V AC dielectric strength test for 1 minute without breakdown), are permitted on a continuous basis. This complies with test requirements outlined in ANSI C39.5-1974 for voltage ratings specified.

**RFI Resistance:** Withstands RFI field strengths of up to 10V per meter at 27MHz, 151MHz, and 467MHz with no digital effect, per SAMA PMC 33.1 test procedures.

**Line Noise Effects:** Field and power line terminals withstand ANSI/IEEE C37.90-1978 Surge Withstanding Capability (SWC) Test with no component failures. Unit is tested to a standardized test waveform that is representative of surges (high-freq. transient electrical interference), observed in actual installations.

**Communication Connections:** Network repeater – both RS-485 connections use modular terminal blocks with screw clamps. Wire range is 14 to 26 AWG.

**Power Wire Connections:** Network repeater terminal block. See label on unit for power to be applied to unit.

**Approvals:** UL/cUL Listed, US & Canada, Energy Management Equipment.

**Shipping Weight:** 3.0 pounds (1.4 kg) packed per unit.

## REPEATER INSTALLATION

### Mounting

Refer to Figure 1 below for mounting and clearance dimensions.

This device is packaged in a rugged aluminum enclosure and no auxiliary enclosure is required for most applications. Mounting holes are provided for surface mounting the unit. You may use an auxiliary enclosure to protect the unit in unfavorable environments or vulnerable locations.

### Termination Jumpers

Any RS-485 network will require that the network be properly terminated at the ends of a network, or network segment. Termination is usually found at the first and last node of a network segment. Since a repeater is used to segment a network, two sets of termination resistors will be required. One at the input side and one at the output side.

Model 4683-TTM-XF units include selectable End-Of-Line (EOL) termination resistors that can be enabled or disabled by positioning jumper blocks on headers installed on the circuit board (see Figure 2). You will have to remove the top cover to gain access to these jumpers. Be sure to turn power OFF before removing the cover or setting these jumpers. Simply remove the single screw on each side of the enclosure and slide the top cover off. Refer to Figure 2 of the following page to locate and set these jumpers as required for your installation.

Optionally, you may leave these jumpers in their disabled position and attach 120Ω termination resistors externally, between the RT terminals adjacent to the network connections, but this can only be used if the trunk bias is applied somewhere else on the network (Reference Section 4.4.1 "Idle-line Fail-safe" of the TIA Telecommunications systems bulletin application guideline for TIA/EIA-485A).

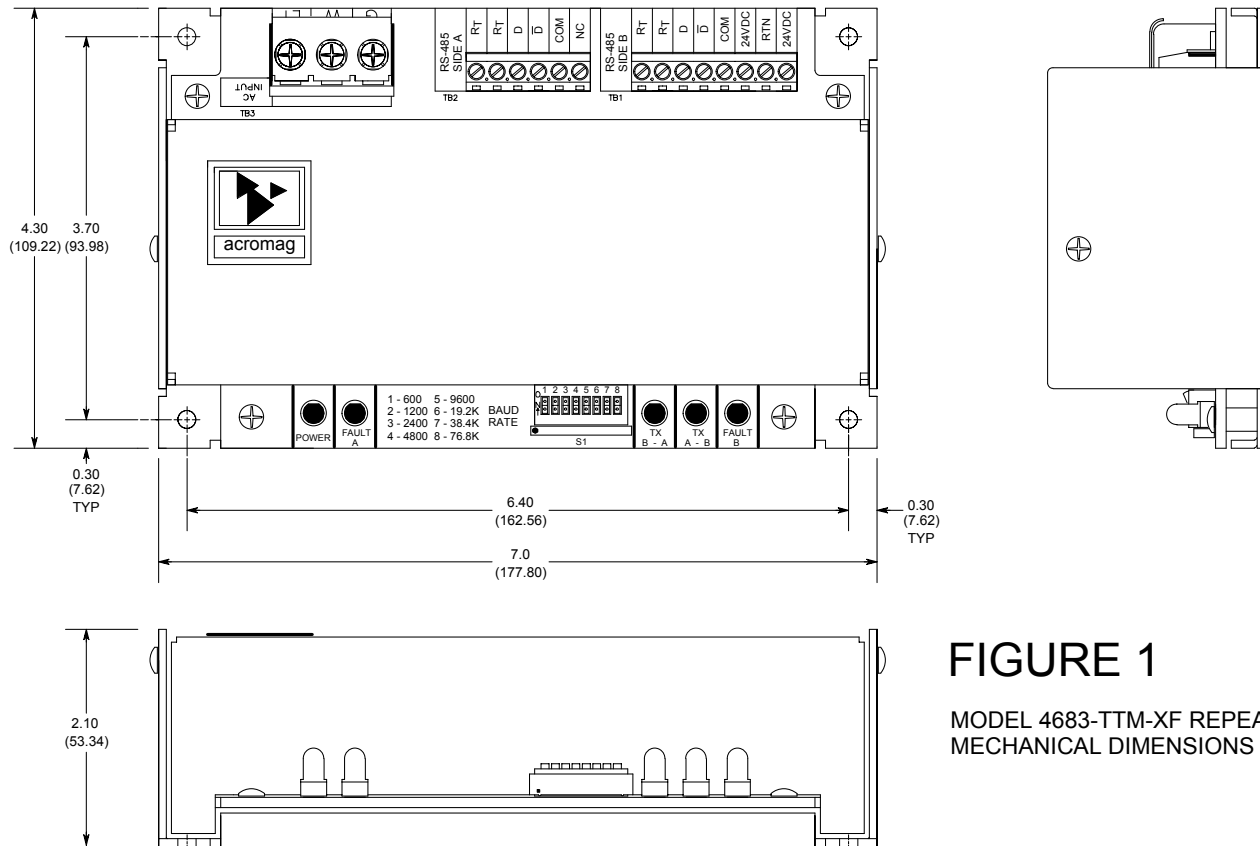
### Setting The Baud Rate

The unit includes an 8-position DIP switch (S1) along the bottom edge. This switch is used to set the baud rate of the repeater. Only the switch that corresponds to the required baud rate should be closed (refer to label information next to S1)—all other switches must be left in the OPEN position.

### Electrical Connections (Refer To Figures 1-4)

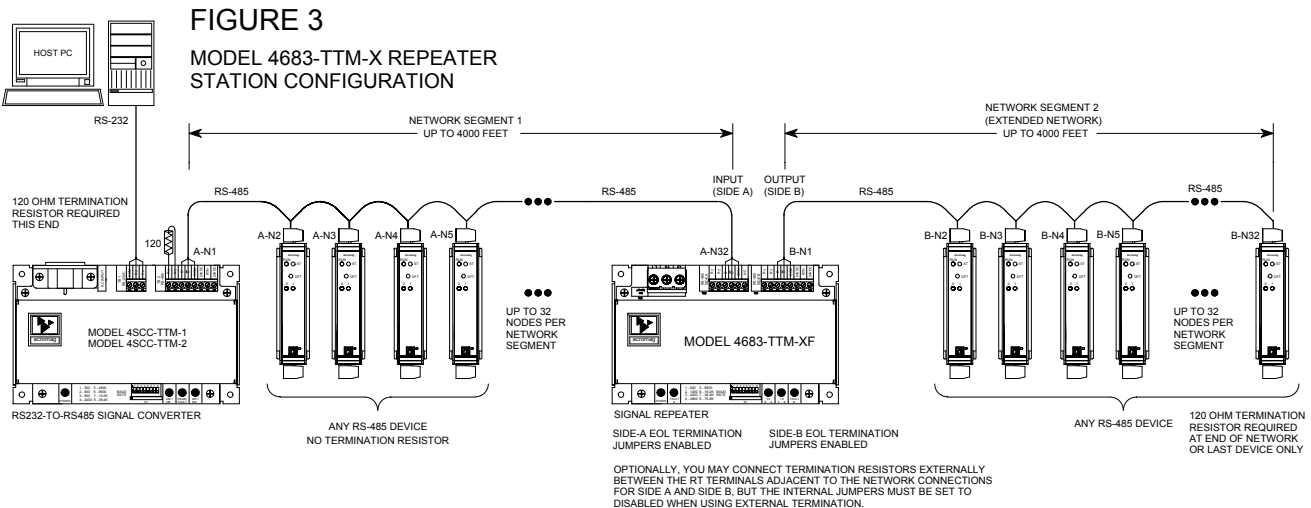
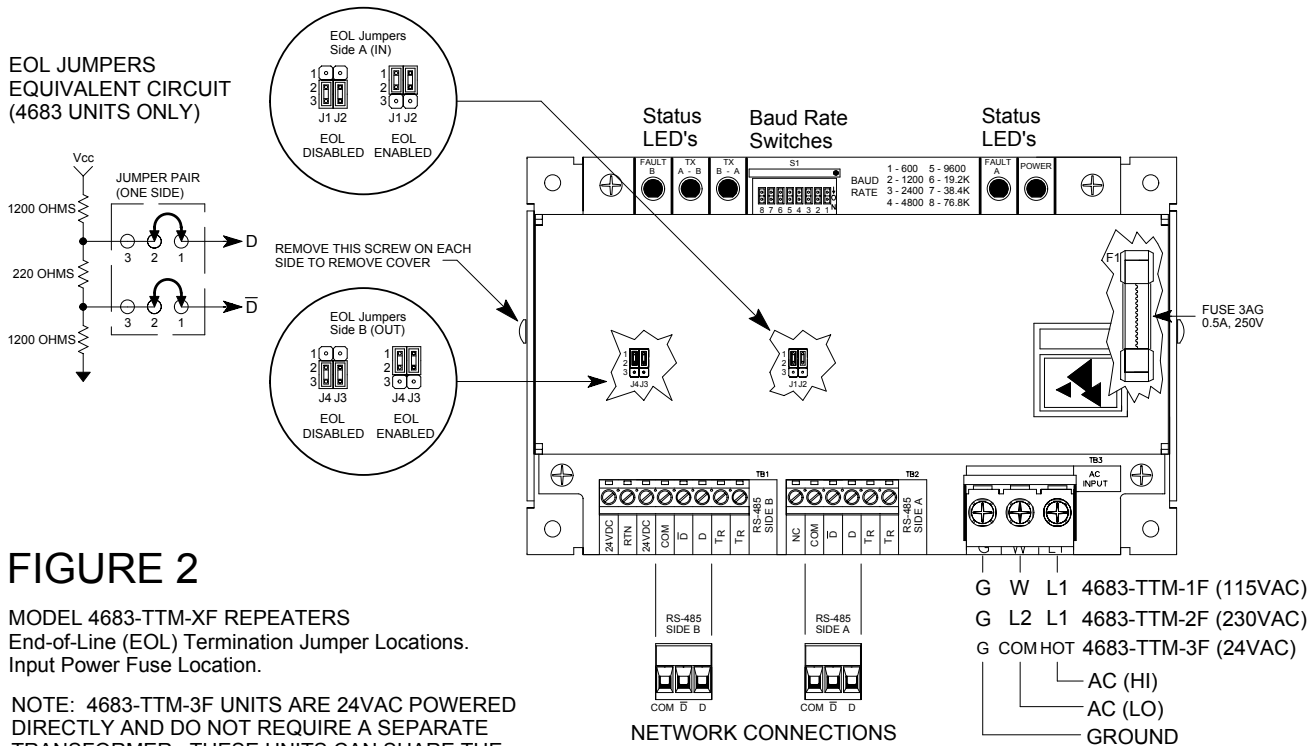
Terminals can accommodate wire from 14-26 AWG, solid or stranded.

- 1. Network - Input (Side A) & Output (Side B):** Connect unit as shown in Figures 3 and 4. Be sure to enable EOL termination as required at the ends of the network. Make sure the baud rate DIP switches are set to match the data rate of the network.
- 2. Power:** Connect AC power as shown in Figure 4 according to model number. Input power is fused (3AG type, 0.5A, 250V). Refer to Figure 2 to locate this fuse if the red power LED fails to light with power applied.
- 3. Ground:** Ground unit at AC input ground (G) terminal. The chassis is common to this earth ground connection.

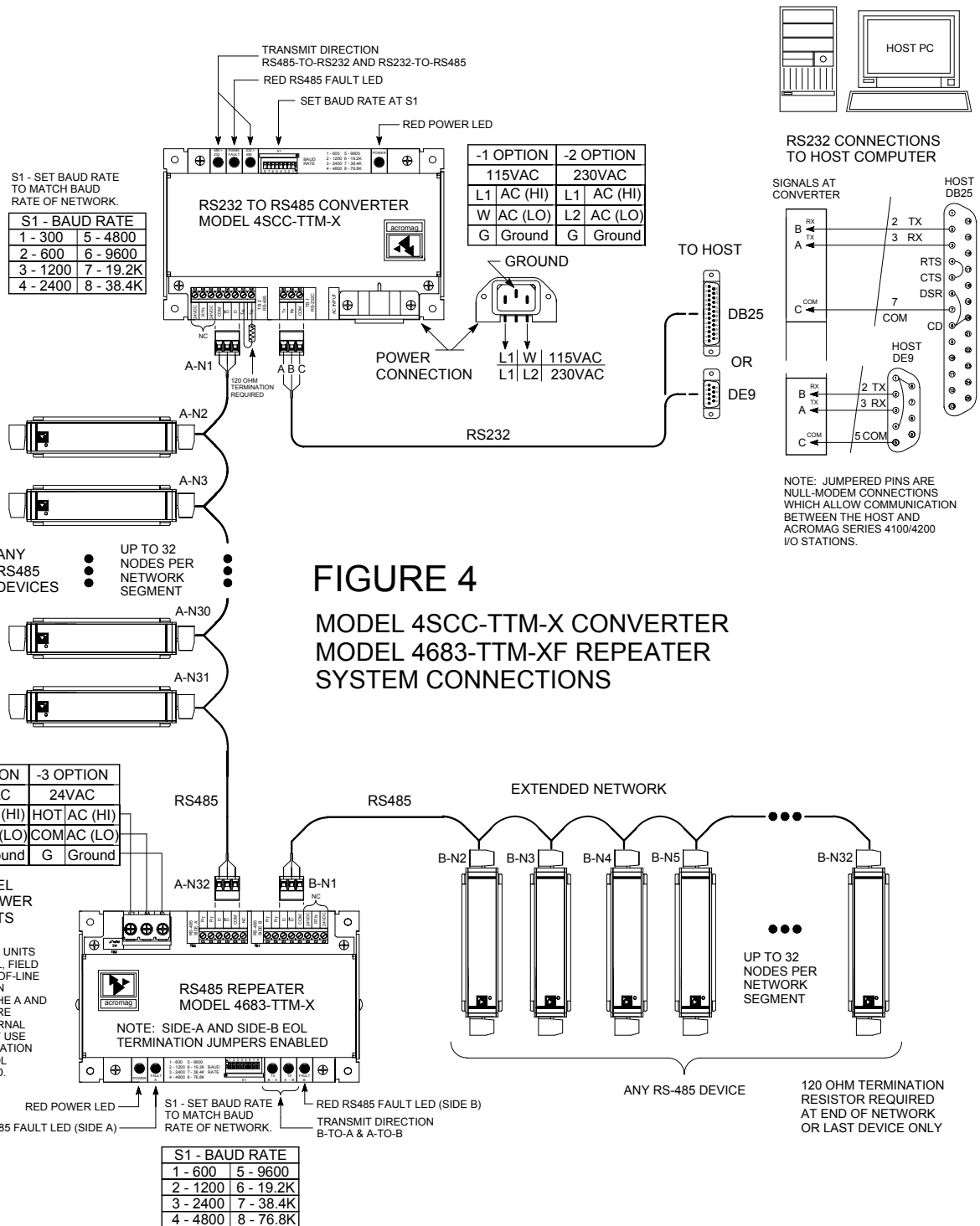


**FIGURE 1**

MODEL 4683-TTM-XF REPEATER  
MECHANICAL DIMENSIONS



The station configuration drawing of Figure 3 is for general illustration purposes only. Johnson Controls systems customers should instead refer to the Metasys® Network Technical Manual for N2 Bus Communication, or the MS/TP Communication Bus Technical Bulletin for wiring connections using the 4683-TTM-xF repeater.



**FIGURE 4**  
 MODEL 4SCC-TTM-X CONVERTER  
 MODEL 4683-TTM-XF REPEATER  
 SYSTEM CONNECTIONS

The station configuration drawing of Figure 4 is for general illustration purposes only. Johnson Controls system customers should instead refer to the Metasys® Network Technical Manual for N2 Bus Communication, or the MS/TP Communication Bus Technical Bulletin for wiring connections using the 4683-TTM-xF repeater.