

INSTALLATION AND OPERATION MANUAL

REGENERATIVE DRIVE

MODEL KBRG-212D

Part No. 8819

VARIABLE SPEED SCR CONTROL

FULL WAVE 4-QUADRANT

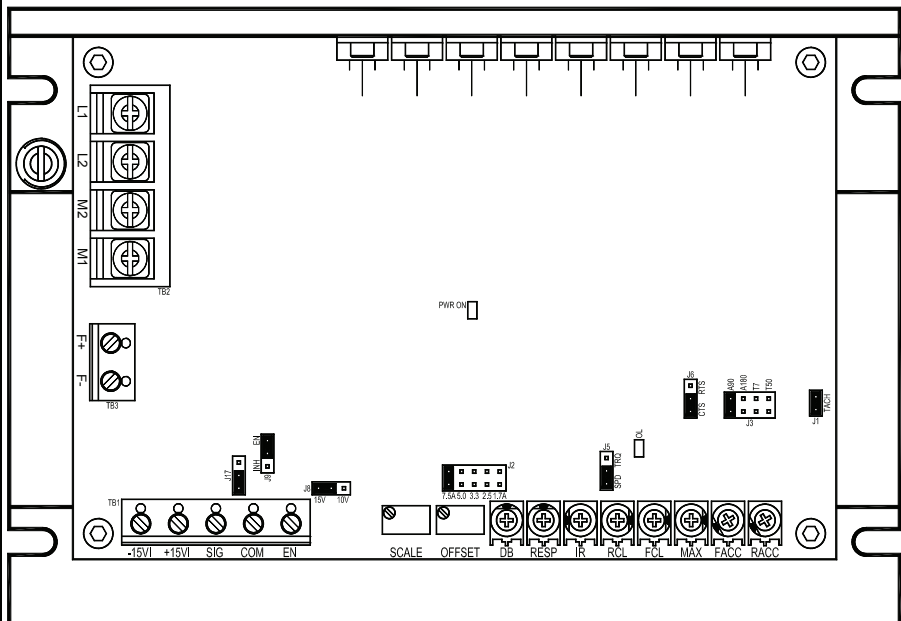

 See Safety
Warning, on page 5.

RoHS
COMPLIANT

c UL US

CE

The information contained in this manual is intended to be accurate.
However, the manufacturer retains the right to make changes in design, which may not be included herein.

PENTA KB POWER™

A COMPLETE LINE OF MOTOR DRIVES

© 2009 KB Electronics, Inc.
(see back cover)

TABLE OF CONTENTS

<u>Section</u>	<u>Page</u>
1 Quick-Start Instructions	4
2 Safety Warning	5
3 Introduction	6
4 Important Application Information	12
5 Mounting Instructions	12
6 Electrical Connections	13
7 Setting Selectable Jumpers / Connector	19
8 Recommended High Voltage Dielectric Withstand Testing (Hi-Pot)	23
9 Drive Operation	24
10 Trimpot Adjustments	25
11 Diagnostic LED's	30
12 Troubleshooting	30
Limited Warranty	Back Cover

<u>Table</u>	<u>Page</u>
1 Standard Features	7
2 Selectable Jumpers	7
3 Trimpot Adjustments	8
4 Electrical Ratings	9
5 General Performance Specifications	9
6 Terminal Block Wiring Information	13
7 Armature Fuse Chart	14
8 Field Connection	15
9 Jumper J2 Setting vs. Motor Horsepower	19
10 Summary of Control (Regen) Operation	25
11 Troubleshooting Guide	30

<u>Figure</u>	<u>Page</u>
1 Control Layout	10
2 Mechanical Specifications	11
3 AC Line and Armature Connection	14
4 Full Voltage Field	15
5 Half Voltage Field	15
6A Unidirectional Operation (Forward)	16
6B Unidirectional Operation (Reverse)	16
6C Bidirectional Operation Reversing Contact	16
6D Bidirectional with Potentiometer	16
7A Voltage Following	17
7B Current Following	17
7C J17 Voltage Scale	18
7D J8 Current Scale	18
8A Enable Mode	18
8B Inhibit Mode	18
9 J1 Tach-Generator Connection	19
10 J2 Armature Current Jumper	19
11A J3 Armature Voltage (90V)	20
11B J3 Armature Voltage (180V)	20
12 J5 Speed /Torque	20
13 Speed Mode vs. Motor Load	20
14 Motor Speed vs. Applied Motor Load (Torque Mode)	21
15 J6 CTS / RTS Jumper	2

TABLE OF CONTENTS (Continued)

Figure		Page
16	J8 15V / 10V Jumper	22
17A	J17 Analog Signal Input (Voltage Position)	22
17B	J17 Analog Signal Input (Current Position)	22
18	J9 Enable / Inhibit Jumper	22
19	Typical Hi-Pot Test Setup	24
20A	Forward and Reverse Acceleration Trimpot Position	26
20B	ACCEL Trimpot Adjustment	26
21	Maximum Speed Trimpot Position	26
22A	Forward Current Trimpot Position	27
22B	Reverse Current Trimpot Position	27
23	IR Compensation Trimpot Position	27
24	Response Trimpot Position	28
25A	Deadband Trimpot Position	28
25B	Deadband Trimpot Adjustment	28
26A	Offset Trimpot Position	29
26B	Offset Trimpot Adjustment	29
27A	Scale Trimpot Position	29
27B	Scale Trimpot Adjustment	29

1 QUICK-START INSTRUCTIONS

Important: You must read these simplified instructions before proceeding. These instructions are to be used as a reference only and are not intended to replace the details provided herein. You must read the SAFETY WARNING, on page 5, before proceeding.

1.1. Connections (See Figure 3, on page 14).

Note: There are no AC Line or Armature fuses supplied with this control. See Section, 1.1.2.

1.1.1 AC Line – Connect AC line voltage (115 or 230 VAC) to terminals L1 and L2. Connect ground wire (earth) to the green ground screw.

1.1.2 Fusing – The KBRG-212D does not contain AC line or armature fusing. It is recommended that a 20 Amp fuse or circuit breaker be installed on each AC line conductor not at ground potential. Do not fuse ground or neutral wires.

1.1.3 Ground Connection – Earth ground the control chassis using the green ground screw that is provided on the control,s heat sink (near TB2).

1.1.4 Motor (See Figure 3, on page 14).

a. Permanent Magnet (PM Type). Connect motor armature leads to M1+ and M2-.

Note: Motor performance and efficiency, including brush life, can be adversely affected when using 90 volt motors with a 230 VAC line. Contact motor manufacturer for derating information.

b. Shunt Wound Motors. Connect motor armature leads as above. Connect full voltage shunt field leads (90 volt motors with 100 volt fields and 180 volt with 200 volt fields) to F+ and F-. Connect half voltage field leads (90 volt motors with 50 volt fields and 180 volt motors with 100 volt fields) to F+ and L1.

1.2 ENABLE/INHIBIT– The control can be electronically stopped and started with this circuit function. To “Stop” the control, Terminals must be connected in the required position, by selecting the type of mode, via J9. See Figure 8B and Section 6.10, on page 18.

In the Enable Mode, the control can also be started and stopped with an Enable circuit (the Enable circuit functions opposite to that of the inhibit circuit; Inhibit: open to start, close to stop, Enable: open to stop, close to start). The Enable function can also be established by wiring a contact in series with the high side of the Main Speed Potentiometer lead connected to Terminal P3. See Figure 8A and Section 6.10, on page 18.

1.3 SPEED OR TORQUE MODE: Jumper J5 is factory set for Speed (SPD) control operation. For torque control, set J5 to the Torque (TRQ) position. See Section 7.3, on page 20.

1.4 JUMPER SETTINGS: All jumpers are set for the KBRG-212D version. The control is factory jumpered for the Enabled mode. See Section 7, on page 19.

1.5 TRIMPOT SETTINGS – All trimpots have been factory set. See Figure 1, on page 10 and Section 10, on page 25.

1.6 SIGNAL INPUT – Connect potentiometer or analog input to TB1, terminals “-15,” “+15” “SIG,” and “COM” according to Section 6, on page 16.

2 SAFETY WARNING

Definition of Safety Warning Symbols



Electrical Hazard Warning Symbol: Failure to observe this warning could result in electrical shock or electrocution.



Operational Hazard Warning Symbol: Failure to observe this warning could result in serious injury or death.



SAFETY WARNING! Please read carefully before proceeding.

This product should be installed and serviced by a qualified technician, electrician, or electrical maintenance person familiar with its operation and the hazards involved. Proper installation, which includes electrical connections, mounting and adequate enclosure, fusing or other current protection, and grounding can reduce the chance of electrical shocks, and/or fires in this product or products used with this product, such as electric motors, switches, coils, solenoids, and/or relays. Do not use this drive in an explosion-proof application. Eye protection must be worn and insulated adjustment tools must be used when working with drive under power. This product is constructed of materials (plastics, metals, carbon, silicon, etc.) which may be a potential hazard. Proper shielding, grounding, and filtering of this product can reduce the emission of radio frequency interference (RFI) which may adversely affect sensitive electronic equipment. The input circuits of this drive may not be isolated from the AC line. Be sure to read and follow all instructions carefully. Fire and/or electrocution can result due to improper use of this product.

The drive may contain electronic start/stop circuits, which are used for "Start" and "Stop" functions. However, these circuits are never to be used as safety disconnects since they are not fail-safe. Use only the AC line for this purpose.

It is the responsibility of the equipment manufacturer and individual installer to supply this Safety Warning to the ultimate end user of this product. (SW 7/2009)



This product complies with all CE directives pertinent at the time of manufacture. Contact our Sales Department for Declaration of Conformity. Installation of a CE approved RFI filter is required. Additional shielded cable and/or AC line cables may be required along with a signal isolator.

3 INTRODUCTION

Thank you for purchasing the KBRG-212D. KB Electronics is committed to providing total customer satisfaction by producing quality products that are easy to install and operate. The KBRG-212D is manufactured with Surface Mount Technology (SMT), incorporating advanced circuitry, components and technology.

The KBRG -212D has an Enable (EN) / Inhibit (INH) mode. The 212D version is factory set (J9 jumper) to Enable (EN). If the user requires the 213D Inhibit (INH) mode, the jumper, J9, is moved to that position.

The KBRG-212D is a full-wave regenerative drive capable of operating DC PM (Permanent Magnet) or Shunt motors in a bidirectional mode. Its 4-quadrant operation provides forward and reverse torque in both speed directions. This allows the control to maintain constant speed with overhauling loads and provides rapid instant reversing and controlled braking. Because of its excellent controllability and response time, the KBRG-212D can replace servos in many applications. The control is factory set for armature feedback, which can provide 1% load regulation over a motor base speed of 50:1. However, tachometer feedback is also available if superior regulation is required. By resetting mode jumper J5 to the "TRQ" position, the KBRG-212D can be changed from a speed control to a torque control.

In addition, the KBRG-212D is used to isolate, amplify, and condition DC voltage signals from any external source (power supplies, motors, tachometer generators, transducers, and potentiometers). The KBRG-212D also provides isolation for motor direction switching and an isolated power supply for transducer or potentiometer operation.

All input and signal connections are made via Terminal blocks and are electrically isolated from AC line and motor wiring.

The KBRG -212D features an Enable (EN) and Inhibit (INH) function (J9). Having both these features allows the drive to be used in applications that previously used the KBRG-212D (Enable) or the KBRG-213D (Inhibit). The control can be electronically stopped and started with the Enable / Inhibit circuit. (The Enable circuit functions opposite to that of the inhibit circuit; Inhibit: open to start, close to stop, Enable: open to stop, close to start).

The drive contains a variety of "selectable" jumpers and adjustment trimpots to allow for custom tailoring for exact requirements.

Another important feature is the LED indicators (PWR ON, OL), which indicate the mode of operation the drive is in, and also serves as a diagnostic tool.

Reliability of the KBRG-212D is further enhanced with the use of high speed current limiting and MOV transient protection. A 5k Ω remote potentiometer and full operating instructions are supplied. See Figures 1 and 2, on pages 10 and 11. In addition, see Tables 1 – 6, on pages 7 – 9.



WARNING! BE SURE TO FOLLOW ALL INSTRUCTIONS CAREFULLY. FIRE OR ELECTROCUTION CAN RESULT DUE TO IMPROPER USE OF THIS PRODUCT. READ SAFETY WARNING ON PAGE 5.

TABLE 1 – STANDARD FEATURES

Feature	Description
Terminal Blocks (See Section 6, on page 13.)	Facilitates wiring of AC line, motor armature and field, TB1 (-15V, +15V, SIG, COM, EN), TB2 (L1, L2, M2, M1), TB3 (F+, F-).
Connectors (See Section 7, on page 19.)	J1, Tach-Generator Input – Connection point for an external Tach-Generator.
Selectable Jumpers (See Section 7, on page 19.)	J2 - Motor Armature Current J3 - Motor Armature Voltage J5 -SPD / TRQ – (Speed / Torque) J6 -CTS/RTS – (Coast to Stop / Regenerate to Stop) J8 -Signal Input Source (15V or 10V) J9 - Enable (EN) / Inhibit (INH) J17- Analog Signal Input (Voltage/Current)
Trimpots (See Section 10, on page 25.)	Provide adjustment for Forward Acceleration (FACC), Reverse Acceleration (RACC), Maximum (MAX), Forward Current Limit (FCL), Reverse Current Limit (RCL), IR Compensation (IR), Response (RESP), Deadband (DB), Offset (OFFSET), and Scale (SCALE).
Diagnostic LEDs (See Section 11, on page 30.)	For Power On (ON), and Current Limit (OL) indications. (Current Overload gives indication that the control will trip).

TABLE 2 – SELECTABLE JUMPERS (See Section 7, on page 19)

Feature	Description
J2-Motor Current, Refer to Section 7.1, on page 19.	For selection of the motor current being used.
J3 – Motor Armature Voltage, Refer to Section 7.2, on page 20.	For selection of the motor voltage being used.
J5-SPD / TRQ, Speed or Torque, Refer to Section 7.3, on page 20.	Jumper position is selectable for either Speed (SPD) or Torque (TRQ) modes.
J6-CTS/RTS. Refer to Section 7.4, on page 21.	For selection of Coast to Stop (CTS) and Regenerate to Stop (RTS). Works in conjunction with the Enable circuit.
J8-Signal Input (15V or 10V). Refer to Section 7.5, on page 22.	Used for selection of potentiometer (15V) or use if the control is to be used from a 0 – $\pm 10/\pm 15$ VDC.
J17-Signal Input. Refer to Section 7.6, on page 22.	Input signal connection for the use with the Main Speed Potentiometer. Used for accepting a 0 – ± 10 V or 0 – ± 25 V signal or 4 – 20 ma.
J9-EN (Enable) / INH (Inhibit). Refer to Section 7.7, on page 22.	For selection of electronically starting and stopping the motor. Used in conjunction with J6, CTS/RTS.

TABLE 3 – TRIMPOT ADJUSTMENTS (See Section 10, on pages 25)

Trimpot	Description
Forward Acceleration (FACC). Refer to Section 10.1, page 25.	Sets the amount of time for the motor to accelerate from zero speed to full speed in the forward direction and the time it takes to decelerate in the reverse direction (FACC = Reverse Deceleration). Factory adjusted to 1 second. (Maximum of 15 seconds).
Reverse Acceleration (RACC). Refer to Section 10.1, on page 25.	Sets the amount of time for the motor to accelerate from zero speed to full speed in the reverse direction and the time it takes to decelerate in the forward direction (RACC = Forward Deceleration). Factory adjusted to 1 second. (Maximum of 15 seconds).
Maximum Speed (MAX SPD). Refer to Section 10.2, on page 26.	The MAX trimpot is used to set the maximum output voltage of the control which, in turn, sets the maximum speed of the motor. In the Torque Control Mode. The MAX trimpot setting determines the unloaded motor speed.
Forward Current Limit (FCL). Refer to Section 10.3, on page 26. *	Sets the maximum amount of DC current that the motor can draw. This determines the amount of maximum motor torque in both the Speed Control Mode and Torque Mode.
Reverse Current Limit (RCL) Refer to Section 10.3, on page 26. *	Sets the maximum amount of DC current that the motor can draw. This determines the amount of maximum motor torque in both the Speed Control Mode and Torque Mode.
IR Comp (IR COMP). Refer to Section 10.4, page 27.	The IR Comp is used to stabilize motor speed under varying loads.
Response (RESP). Refer to Section 10.5, on page 28.	This trimpot determines the dynamic response of the control.
Deadband (DB). Refer to Section 10.6, on page 28.	The DB trimpot sets the amount of main speed potentiometer rotation required to initiate control voltage output. It is factory set to approximately 0%. The DB trimpot also determines the amount of delay that will occur before regeneration starts.
Offset (OFFSET). Refer to Section 10.7, on page 29.	This trimpot determines the amount of bias in the forward or reverse direction. The trimpot is factory set to provide approximately zero offset, which means neither the forward nor the reverse speed is favored.
Scale (SCALE). Refer to Section 10.8, on page 29.	This trimpot works in conjunction with the MAX potentiometer for fine tuning of the (voltage or current) of the incoming analog signal.

* FCL and RCL also determine the maximum amount of regenerative braking torque depending on which direction is braking.

TABLE 4 – ELECTRICAL RATINGS

Input Voltage (VAC)	Maximum AC Line Current (Amps RMS)	Output Voltage (Volts DC)	Maximum DC Output Current (ADC)	Maximum Horsepower HP, (KW)
115	12	0 – ±90	7.5	¾, (0.5)
208/230	12	0 – ±180	7.5	1.5, (1)

TABLE 5 – GENERAL PERFORMANCE SPECIFICATIONS

Parameter	Specification	Factory Setting
AC Line Input Voltage (VAC, ±10%, 50/60 Hz)	115 or 208/230	208/230
Armature Voltage Range at 115 VAC Line (VDC)	0 – ±90	—
Armature Voltage Range at 230 VAC Line (VDC)	0 – ±90, 0 – ±180	0 – ±180
Field Voltage at 115 VAC Line (VDC)	100 / 50	—
Field Voltage at 230 VAC Line (VDC)	200 / 100	—
Max Load Capacity (% for 2 Minutes)	150	—
Ambient Temperature Range (°C / °F)	0 – 40 / 32 – 104	—
Speed Range (Ratio)	50:1	—
Arm Feedback Load Regulation (% Base Speed)	±1	—
Tach Feedback Load Regulation (% Set Speed)	±1	—
AC Line Regulation (% Base Speed)	±0.5	—
Current Ranges (Amps DC)	1.7, 2.5, 5.0, 7.5	7.5
FWD and REV Accel Range (Seconds)	0.1 – 15	1
Deadband Range (% Base Speed)	0 – ±5	0
Max Speed Trimptot Range (% Base Speed)	55 – 110	100
IR Comp Range at 115 VAC Line (VDC)	0 – 20	5
IR Comp Range at 230 VAC Line (VDC)	0 – 40	10
FCL and RCL Range (% Range Setting)	0 – 175	150
Voltage Following Input Range (VDC)	±5 – ±25	0 – ±10, 0 – ±15
Voltage Following Linearity (% Base Speed)	±0.5	—

FIGURE 1 - CONTROL LAYOUT

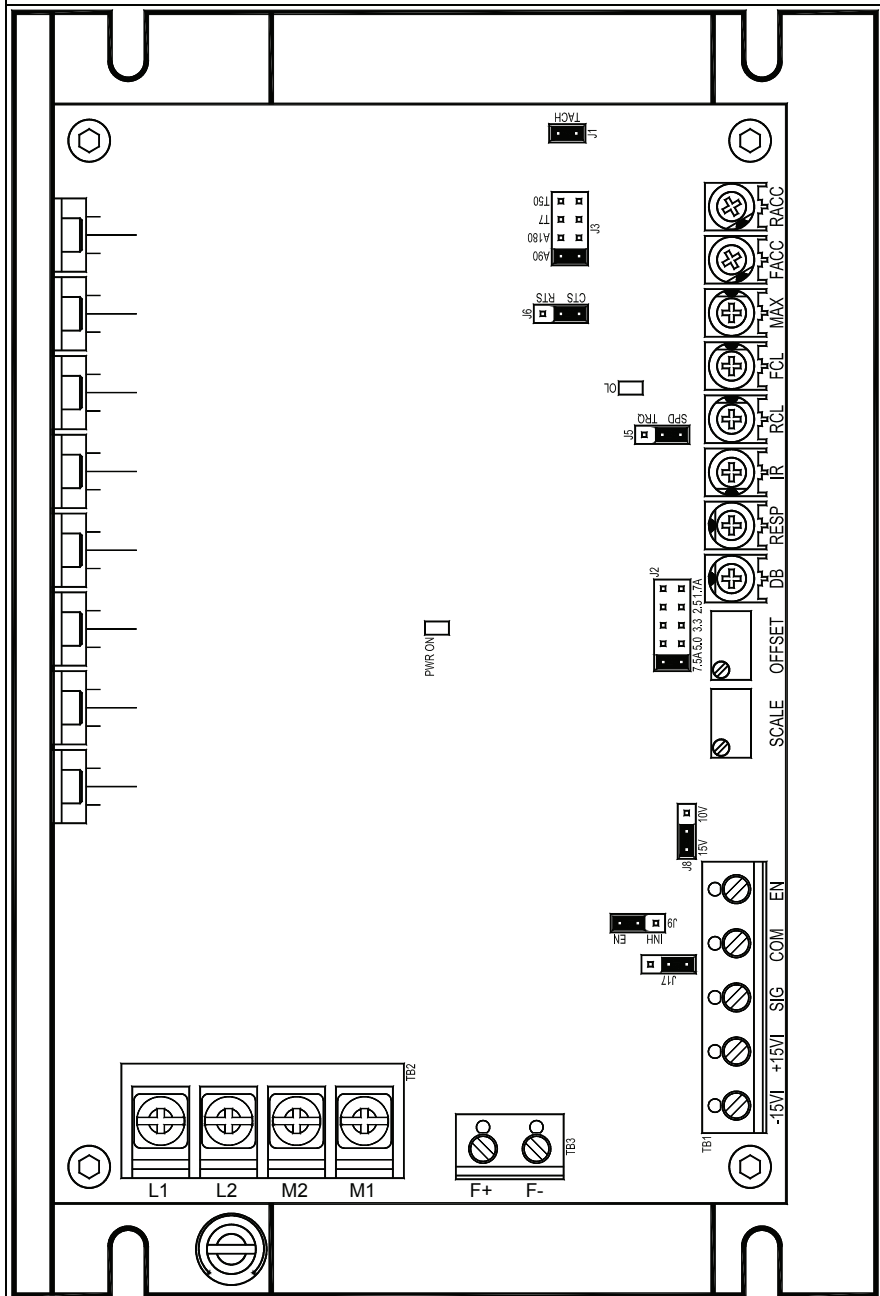
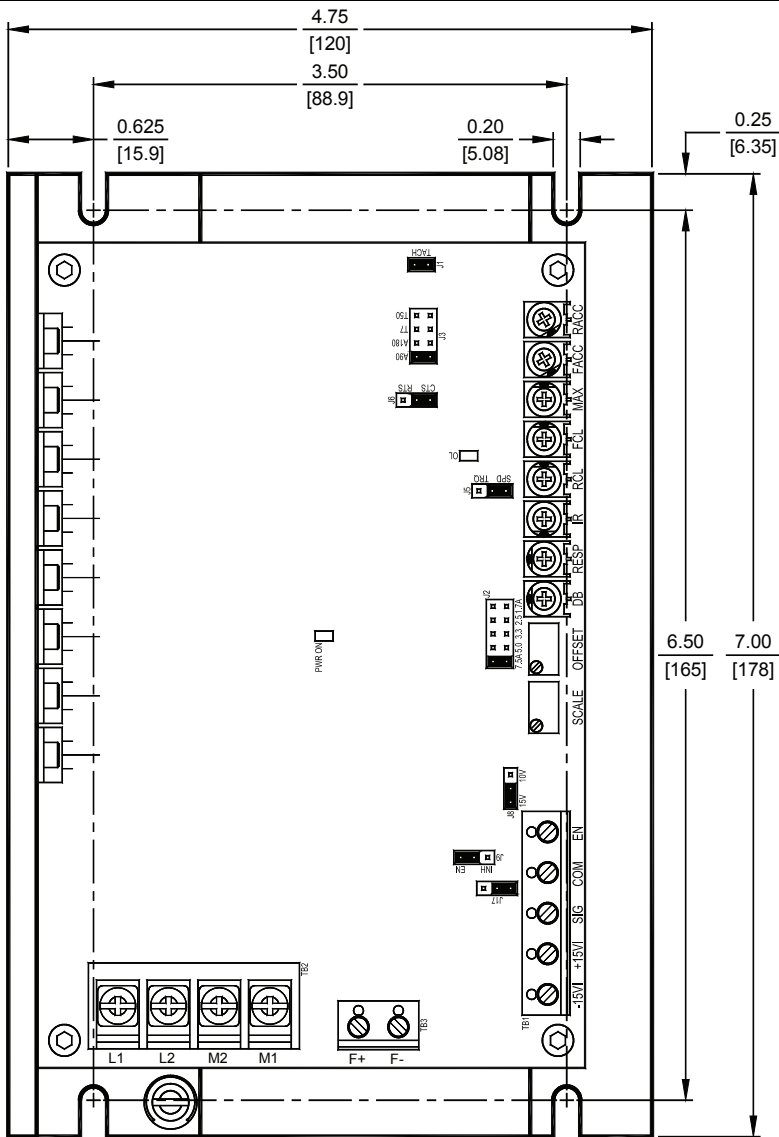

FIGURE 2 - MECHANICAL SPECIFICATIONS (Inches / [mm])



MAXIMUM HEIGHTS	
Without Accessory Boards	With Accessory Boards
1.70 [43.2]	3.10 [78.7]

4 IMPORTANT APPLICATION INFORMATION



WARNING! DO NOT USE THIS DRIVE IN AN EXPLOSIVE ENVIRONMENT. AN EXPLOSION CAN CAUSE SERIOUS OR FATAL INJURY. THIS DRIVE IS NOT EXPLOSION PROOF.



WARNING! BE SURE TO FOLLOW ALL INSTRUCTIONS CAREFULLY. FIRE OR ELECTROCUTION CAN RESULT DUE TO IMPROPER USE OF THIS PRODUCT. READ SAFETY WARNING ON PAGE 5.

- 4.1 Motor Type** – The KBRG-212D is full-wave regenerative control, capable of operating a DC motor (Permanent Magnet (PM), or Shunt), in a Bi-Directional mode. Be sure the drive is used within its stated specifications.
- 4.2 Torque Requirements** – When replacing an AC induction motor with a DC motor and speed control, consideration must be given to the maximum torque requirements. The full load torque rating of the DC motor must be equal to, or greater than, that of the AC motor.
- 4.3 Acceleration Start** – The KBRG-212D contains an adjustable acceleration start feature that allows the motor to smoothly accelerate from 0-full speed over a time period of 0.5 to 15 seconds.
- 4.4 Limitation in Use** – The KBRG-212D controls are designed for use on machine applications.

CAUTION! - Do not use in explosive atmosphere. Be sure the KBRG-212D is used within its maximum ratings. Follow all installation instructions carefully (Refer to Sections 4 and 5).

5 MOUNTING INSTRUCTIONS

Mount the KBRG-212D on a flat surface free of moisture, metal chips, or corrosive atmosphere. Refer to Figure 2, on page 11.

A 5k Ω ohm remote potentiometer is provided. Install the potentiometer using hardware provided. Be sure to install insulating disk between potentiometer and inside of front panel.

Enclosure – When mounting the KBRG-212D in an enclosure, it must be large enough to allow for proper heat dissipation. A 12" x 12" x 24" enclosure is suitable for the KBRG-212D at full rating. Smaller enclosures may be used if full rating is not required.

6 ELECTRICAL CONNECTIONS



WARNING! READ SAFETY WARNING, ON PAGE 5, BEFORE USING THIS CONTROL.

CAUTION! To avoid erratic operation, do not bundle AC line and motor connections with potentiometer connections, voltage following connections, Start/Stop switch connections, inhibit connections, or any other signal connections. Use shielded cables on all signal connections over 12" (30 cm) long. Shield should be earth grounded on the control side only.

Connect control in accordance with National Electric Code requirements and other local codes that apply. The KBRG-212D does not contain AC line or armature fusing. It is recommended that a 20 Amp fuse or circuit breaker be installed on each AC line conductor not at ground potential. Connect control, in accordance with illustrations in this section. A separate AC line switch or contactor must be connected as a disconnect switch so that contacts open each ungrounded conductor. In addition, Table 6, details the connection, wiring and torque information.

TABLE 6 – TERMINAL BLOCK WIRING INFORMATION

Terminal Block Designation	Connection Designation	Supply Wire Gauge (AWG – Copper)		Maximum Tightening Torque (lbs- in)
		Minimum	Maximum	
TB1	Power / Control Connections	22	14	3.5
TB2	L1, L2, M1, M2	18	12	3.5
TB3	F+, F-	22	14	3.5

6.1 AC Line Connection – Connect the AC line to L1 and L2 terminals of TB1 as shown in Figure 3, on page 14.

Note: There are no AC Line or Armature fuses supplied with this control. See Section 6.3, on page 14.

6.2 Motor Armature – Connect motor armature to terminal M1 and M2. (Be sure jumper J3 is set to match motor voltage. See Figure 3, on page 14 and Section 7.2, on page 20.

FIGURE 3 – AC LINE AND ARMATURE CONNECTION

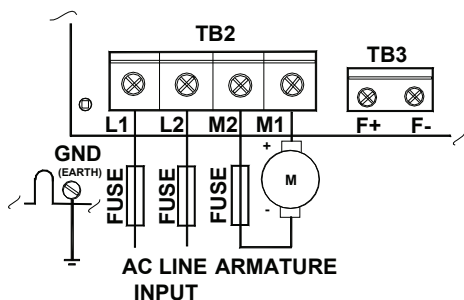

See Table 6, for Torque Requirements.

6.3 Fusing

AC Line Fuse – The KBRG-212D does not contain an AC line fuse or Armature fuse. It is recommended that a **20 Amp fuse or circuit breaker** be installed on each AC line conductor not at ground potential. In addition, refer to Table 7, for recommended Armature Fusing.

CAUTION: Most electrical codes require that each ungrounded conductor contain fusing. Separate branch circuit fusing may be required. Check local electrical codes.

6.4 Motor Armature – Connect motor armature to terminals M1 and M2. Be sure that jumper J2 matches the motor being used. (See Figure 3).

TABLE 7 – ARMATURE FUSE CHART

Motor Horsepower		Approx. DC Motor Current Amps	Fuse Rating (AC Amps)
90 VDC	180 VDC		
1/8	1/4	1.3	2
1/6	1/3	1.7	2 1/2
1/4	1/2	2.5	4
1/3	3/4	3.3	5
1/2	1	5.0	8
3/4	1 1/2	7.5	12
1	2	10.0	20

6.5 Field (For Shunt Wound Motors Only) – Connect motor armature leads as above. Connect full voltage shunt field leads (90 volt motors with 100 volt fields and 180 volt with 200 volt fields) to F+ and F-. Connect half voltage field leads (90 volt motors with 50 volt fields and 180 volt motors with 100 volt fields) to F+ and L1. See Table 8, Figures 4 and 5, on page 15, for field connection diagrams.

CAUTION! Shunt-Wound motors may be damaged if field remains connected without motor rotating for an extended period of time.

Note: Do not connect motor armature leads to F+ and F- terminals. Do not use F+ and F- terminals for PM motors.

TABLE 8 – FIELD CONNECTIONS (Shunt Wound Motors Only)			
AC LINE VOLTAGE	FIELD VOLTAGE (VDC)	FIELD VOLTAGE (VDC)	FIELD CONNECTION
115	90	100	F+, F-
115	90	50	F+, L1
230	180	200	F+, F-
230	180	100	F+, L1
230	*90	100	F+, L1

*Step down operation. See Section 7.2, on page 20.

6.6 Full Voltage Field Connection (Shunt Wound Motors Only) –

Connect the motor field leads to F+ and F- terminals of TB3 as shown in Figure 4, and Table 7, on page 14.

Note: Do not connect motor armature leads to F+ and F- terminals.

CAUTION! Do not use F+ and F- terminals of TB3 for any purpose other than to power the field of a shunt wound motor.

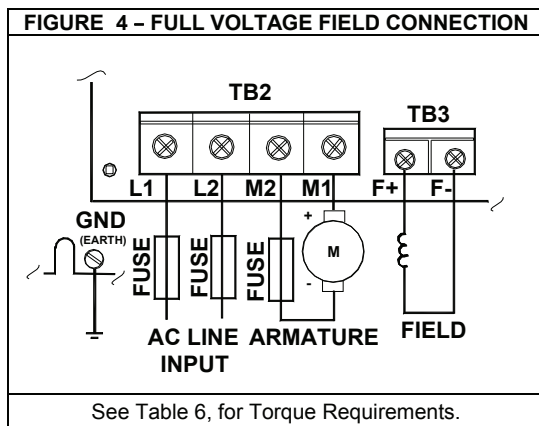

6.7 Half Voltage Field Connection (Shunt Wound Motors Only) –

Connect the motor field leads to F+, TB3 and L1 terminals of TB2, as shown in Figure 5, and Table 7, on page 14.

CAUTION! TB3 terminals are not isolated from AC line. Do not ground (earth).

Note: Do not connect motor armature leads to F+ and F- terminals.

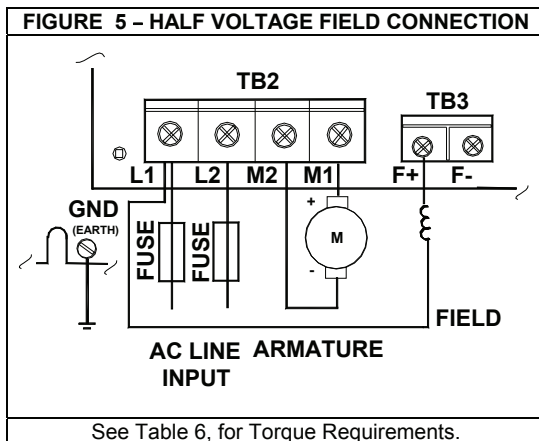

6.8 Main Speed Potentiometer Connection – The main speed potentiometer can be connected in several ways. (A 5kΩ ohm potentiometer is supplied with control. A 10K potentiometer can also be used.) See Figures 6A – 6D.

- 6.8.1 Unidirectional operation (FORWARD)** – Connect potentiometer to terminals “+15,” “SIG,” “COM” for forward direction as per Figure 6A.
- 6.8.2 Unidirectional operation (REVERSE)** – Connect potentiometer to terminals “-15,” “SIG,” “COM” for reverse direction. As per Figure 6B.
- 6.8.3 Bidirectional operation using reversing contacts** – Connect potentiometer to terminals “-15,” “+15,” “SIG,” “COM” as per Figure 6C.
- 6.8.4 Bidirectional operation with potentiometer** – Connect potentiometer to terminals “-15,” “+15” “SIG” as per Figure 6D.

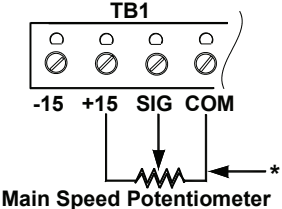
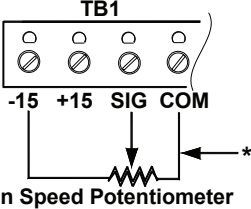
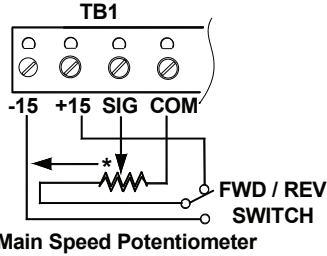
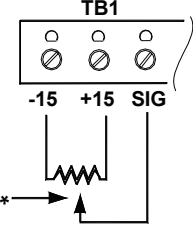
FIGURE 6A – UNIDIRECTIONAL OPERATION (Forward)	FIGURE 6B – UNIDIRECTIONAL OPERATION (Reverse)
 <p style="text-align: center;">Main Speed Potentiometer</p>	 <p style="text-align: center;">Main Speed Potentiometer</p>
FIGURE 6C – BIDIRECTIONAL OPERATION (Reversing Contact)	FIGURE 6D – BIDIRECTIONAL with POTENTIOMETER
 <p style="text-align: center;">Main Speed Potentiometer</p>	 <p style="text-align: center;">Main Speed Potentiometer Center Pot Position = 0 Speed CW = Full Forward CCW = Full Reverse</p>
See Table 6, for Torque Requirements.	
<p>Notes: 1. * Indicates increase in motor speed. 2. A connection must be made between EN and COM terminals (TB1) to operate when J9 is in the EN position.</p>	

6.9 Signal Following – In this mode, a signal source is used to vary motor speed.

6.9.1 Voltage Following – Uses a voltage source to vary motor speed. Set J17 (See Section 7.7 on page 22 for jumper information) to “VOLT” position and connect the voltage source to TB1 terminals SIG (+) and COM (-) (See Figures 7A below and 7C, on page 18), Voltage Following Connection. Be sure the positive (+) signal is connected to “SIG” terminal and the negative (-) is connected to the “COM” terminal. When a 0V DC signal is applied, the motor will operate at the minimum set speed (set by the MIN Trimpot). When a 10V DC signal is applied, the motor will operate at the maximum set speed (set by the MAX Trimpot).

6.9.2 Current Following – Uses a current source to vary motor speed. Set J17 (See Section 7.7 on page 22 for jumper information) to “CUR” position and connect the current source to TB1 terminals SIG (+) and COM (-). See Figures 7B below, and 7D, on page 18.

In addition, the control is used to isolate, amplify, and condition DC voltage signals from any external source (power supplies, motors, tachometer generators, transducers, and potentiometers). Also provides isolation for motor direction, switching and an isolated power supply for transducer or potentiometer operation. See Section 7.7, on page 22.

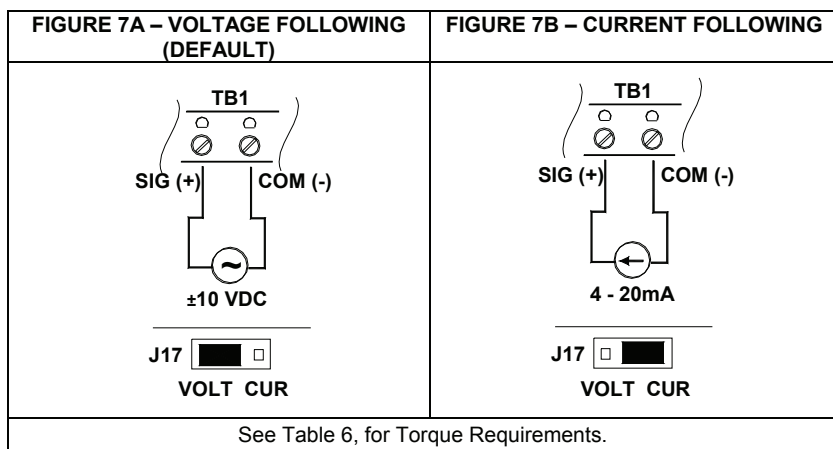

Notes:

1. Jumper J8 must be in the “10V” position.
2. A positive signal with respect to the COM terminal will produce a positive output to motor. A negative signal with respect to the COM terminal will produce a negative output. A 0 to ±10VDC is required to operate control from 0 to ± full output. Jumper J8 must be set to the 10V position.

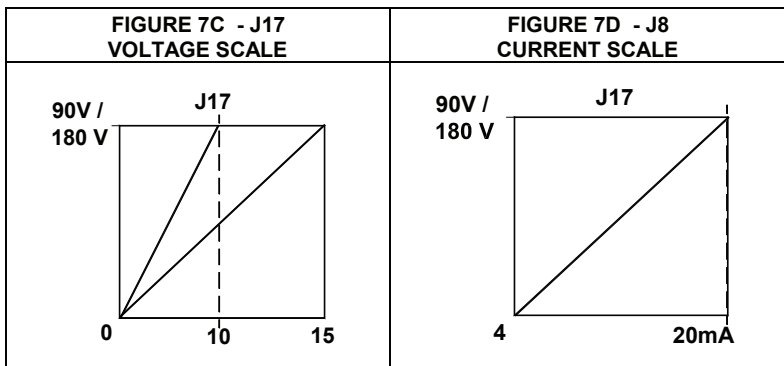

6.10 Enable / Inhibit – The control features an Enable / Inhibit function. The control can be electronically stopped and started with the Enable / Inhibit circuit.

The Enable circuit functions opposite to that of the inhibit circuit. Inhibit: open to start, close to stop. Enable: open to stop, close to start.

6.10.1 Enable Mode, EN (212D) – In the Enable mode (Default) connect COM terminal to the EN terminal via a switch. See Figure 8A.

6.10.1 Inhibit Mode, INH (213D) – When COM terminal and EN terminal are open, control is in “INHIBIT” state. See Figure 8B.

IMPORTANT NOTE: In Enable mode a switch must be installed between the COM and the EN terminals or control will not operate. See SAFETY WARNING, on page 5.

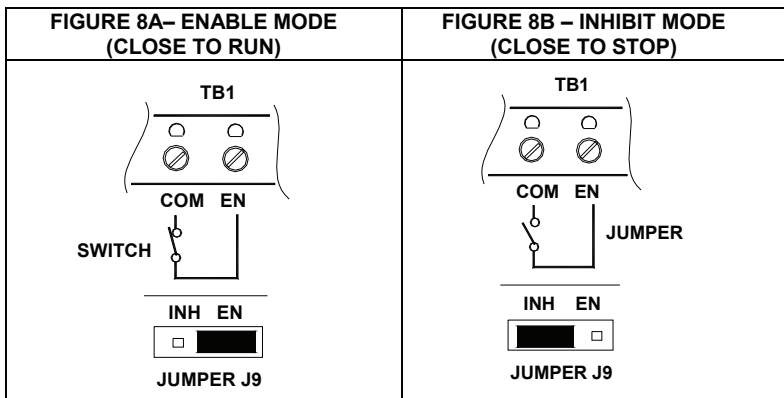

6.11 Tach-Generator Feedback, J1 – The KBRG-212D is factory set for armature feedback which provides good load regulation for most applications. For superior load regulation analog tach-generator feedback can be used.

Connect the tach-generator to J1, so that the polarity of the tach-generator is the same with respect to the input signal polarity.

Note: If tach-generator is wired for reverse polarity, the motor will run at full speed. See Figure 9.

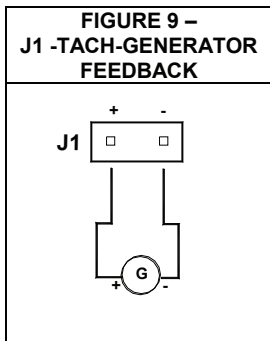

7 SETTING SELECTABLE JUMPERS

The KBRG-212D has customer selectable jumpers which must be set before the control can be used. See Figure 1, on page 10 for jumper locations.

7.1 J2 – Armature Current – Select the J2 position (1.7, 2.5, 3.3, 5, 7.5) closest to the rated motor current. See Figure 10 and Table 9.

Note: The maximum output current is set to 150% of the J2 position, which may be reset using the FCL and RCL Trimpots. See Section 10.3, on page 26.

J2 Position Motor Current (DC Amps)	90 VDC	180 VDC
7.5A	3/4	1 ½
5.0A	1/2	1
3.3A	1/3	3/4
2.5A	1/4	1/2
1.7A	1/6	1/3

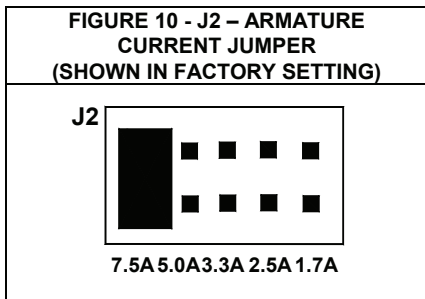

7.2 J3 – Armature Voltage Output and Tach-Generator Feedback – Select the desired armature voltage by placing J3 in the proper position, “A90” or “A180.” See Figure 11A.

Note: For 115 volt AC line input, J3 must be set to “A90.” For 230 input, the armature voltage is normally set for “A180.” However, it is also possible to set the armature voltage to “A90” for stepdown operation.

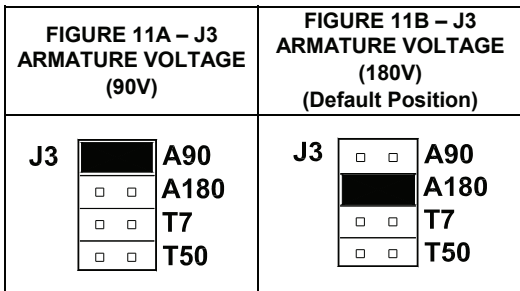

7.2.1 Tach-Generator Feedback (for use with 1800 RPM motors.) – Jumper J3 is also used if tach-generator feedback is to be used. If a 7 volt per 1000 RPM tach-generator is used, set jumper J3 in the “T7” position. For a 50 volt per 1000 RPM tach-generator, set the jumper in the “T50” position. See Figure 11B.

Note: When using tach-generator feedback, the IR Comp Trimpot (See Section 10.4, on page 27) should be turned to a minimum setting (full CCW). See Figure 9, and Section 6.11, on page 19.

7.3 J5 - Speed (SPD) or Torque (TRQ).

Note: Factory setting of J5 is Speed mode (Default).

In the speed control mode (J5 set to SPD), the KBRG-212D will provide variable speed control. The motor speed will be in direct proportion to the input signal. Both forward and reverse torque is used to stabilize motor speed.

See Figures 12, 13 and 14.

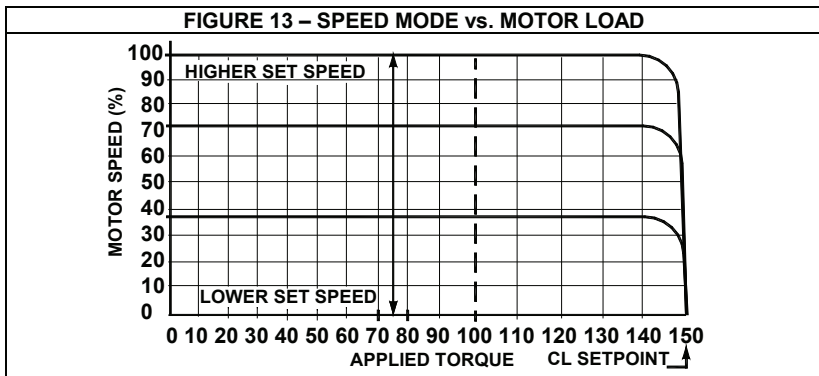
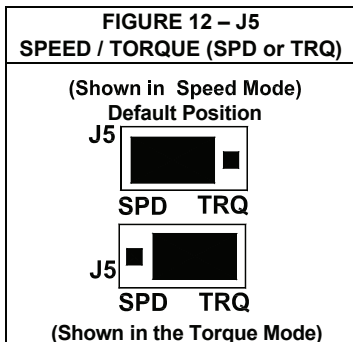

In the torque control mode (J5 set to TRQ), the KBRG-212D will vary the maximum motor torque as a function of the voltage input to terminals "SIG" (signal) and "COM" (common). This voltage can be derived from the wiper of the main potentiometer or from an analog input (voltage following). If the motor torque is greater than the load torque, the motor will rotate. If no load is applied to the motor, the motor will rotate at a speed proportional to the torque setting as set by

FIGURE 14 - MOTOR SPEED vs. APPLIED MOTOR LOAD (TORQUE MODE)

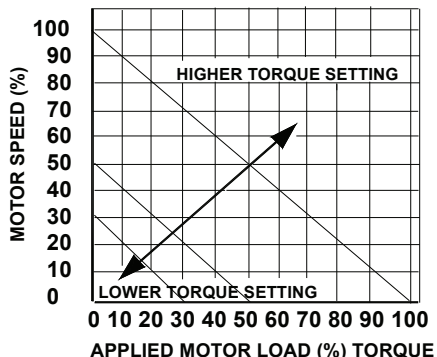

the main potentiometer (See Figure 13, on page 21). By using the FACC and RACC Trimpots, the application of torque can be made more gradual or less gradual as required by the application. A maximum torque can be established using the current selector jumper, J2, which can be further modified by using the FCL and RCL Trimpots.

7.4 J6 – Coast to Stop (CTS) Regenerate to Stop (RTS) - This function operates in conjunction with the Enable circuit, which is used to start and stop the control electronically. If the circuit connecting terminals "EN" and "COM" on terminal block TB1 is opened, the control will cause the motor to stop. When jumper J6 is in the factory position (**RTS**), the motor will regenerate to a stop. The stop time is controlled by the Forward Acceleration (FACC) and Reverse Acceleration (RACC) Trimpots. If J6 is changed to the coast to stop (CTS) position, the motor will coast to a stop when the "EN" - "COM" circuit is opened. See Figure 15.

FIGURE 15 – J6 CTS / RTS JUMPER

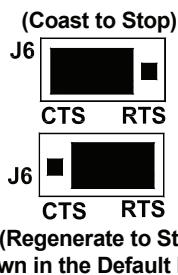

Note: Control will not run unless a jumper or closed contact is connected between the "EN" and "COM" terminals.

7.5 J8 – Analog (Signal) Input Voltage –

The output of this control is normally controlled with the main potentiometer. However, an analog voltage (isolated) may also be used in place of a potentiometer. The control can be scaled for 0 – 10VDC by placing J8 in the appropriate position "15V" or "10V". The scaling can be further adjusted with the SCALE Trimpot. Refer to Section 6.9, (Signal Following) on page 17, and Figure 16, for additional information.

7.6 J17 – Analog Signal Input – J17 is used in conjunction with jumper J8 and the Main Speed Potentiometer for, the input of a voltage or a current signal. Refer to Section 6.9, (Signal Following) on page 17 and Figures 17A and 17B.

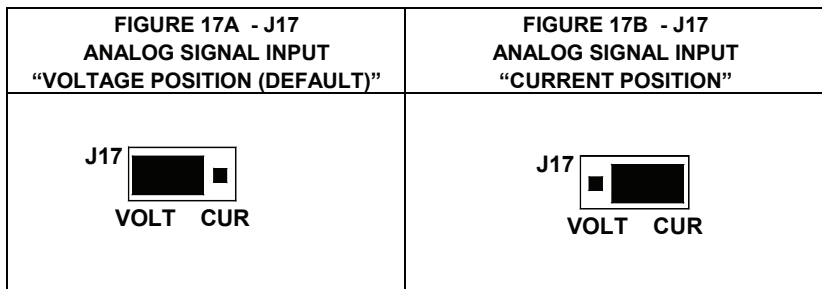
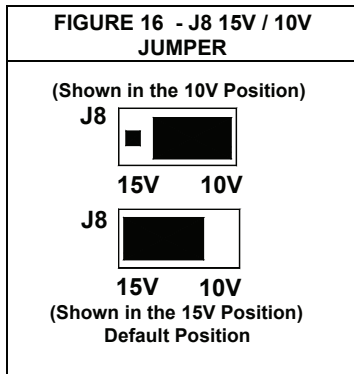

7.7 J9 – Enable (EN) / Inhibit (INH) – The control can be electronically stopped or started with the inhibit circuit, depending upon the position of Jumper, J9. The control can also be started and stopped with the Enable (Factory Set) function. (The enable circuit functions opposite to that of the inhibit circuit). See Figure 18 and Section 6.10, on page 18, for wiring information.

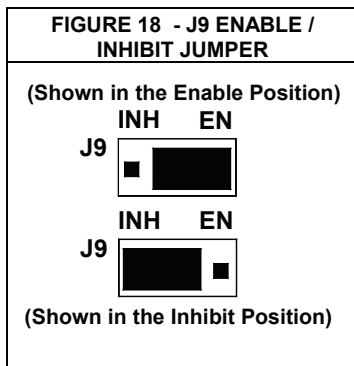

8 RECOMMENDED HIGH VOLTAGE DIELECTRIC WITHSTAND TESTING (HI-POT TESTING)



WARNING! READ SAFETY WARNING ON PAGE 5 BEFORE ATTEMPTING TO OPERATE. SEVERE INJURY OR DEATH CAN RESULT.

Testing agencies such as UL, CSA, etc., usually require that equipment undergo a hi-pot test. In order to prevent catastrophic damage to the drive, which has been installed in the equipment, the following procedure is recommended. A typical hi-pot test setup is shown in Figure 19, on page 24. **All drives have been factory hi-pot tested in accordance with UL requirements.**



WARNING! ALL EQUIPMENT AC LINE INPUTS MUST BE DISCONNECTED FROM THE AC POWER.

- 8.1 Connect all equipment AC power input lines together and connect them to the H.V. lead of the Hi-Pot Tester. Connect the RETURN of the Hi-Pot Tester to the frame on which the drive and other auxiliary equipment are mounted.
- 8.2 The Hi-Pot Tester must have an automatic ramp-up to the test voltage and an automatic ramp-down to zero voltage.

Note: If the Hi-Pot Tester does not have automatic ramping, then the hi-pot output must be manually increased to the test voltage and then manually reduced to zero. This procedure must be followed for each machine being tested. A suggested Hi-Pot Tester is Slaughter Model 2550.

CAUTION! Instantly applying the hi-pot voltage will cause irreversible damage to the drive, which will void the warranty.

FIGURE 19 - TYPICAL HI-POT TEST SETUP

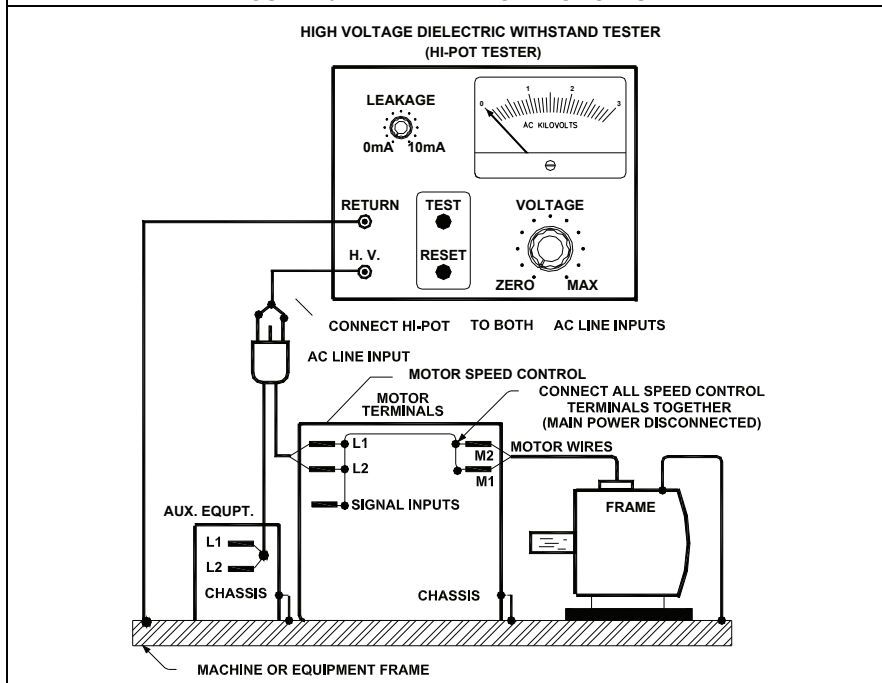

9 DRIVE OPERATION



WARNING! READ SAFETY WARNING ON PAGE 5 BEFORE ATTEMPTING TO OPERATE OR SEVERE INJURY OR DEATH CAN RESULT.

The input voltage can be derived from the wiper of the Main Speed Potentiometer or from an analog input (voltage following mode). Since the KBRG-212D is a 4-quadrant regenerative drives, the motor speed will follow both a positive and negative wiper voltage and drive the motor in both the forward direction and reverse direction. In addition, it will apply both forward and reverse torque in order to stabilize motor speed.

Example: To understand the concept of a regenerative drive, the operation of an elevator can be used. If one were to enter the elevator on the first floor and press 10, the motor and control would have to lift the elevator against gravity. In this mode, the drive would operate like a conventional speed control which is called "motoring" (the applied load is opposite to the direction of motor speed).

When the elevator is at floor 10 and floor 1 is pressed, gravity will try to pull the elevator car down faster than the speed for which it is set. The control will then provide reverse torque to keep the car from falling faster than the set speed. This operation is regeneration (the applied load is in the same direction as the direction of motor rotation). Table 10, on page 25 summarizes the different modes of regen operation.

The KBRG-212D can be operated as speed controls or torque controls by setting the position of jumper J5. The Main Speed Potentiometer controls the magnitude of the mode selected. Set jumper J5 to "SPD" for speed control or to "TRQ" for torque control. See Table 10.

TABLE 10 – SUMMARY OF CONTROL (REGEN) OPERATION

Quadrant	Type of Operation	Motor Rotation Direction	Motor Torque Direction	Applied Load Direction
I	Motoring	CW	CW	CCW
II	Regeneration	CCW	CW	CCW
III	Motoring	CCW	CCW	CW
IV	Regeneration	CW	CCW	CW

10 TRIMPOT ADJUSTMENTS

The KBRG-212D contains trimpots, which are factory set for most applications. Figure 1, on page 10, illustrates the location of the trimpots and their approximate calibrated positions. Some applications may require readjustment of the trimpots in order to tailor the control for a specific requirement. Readjust trimpots as described below.



WARNING! IF POSSIBLE, DO NOT ADJUST TRIMPOTS WITH MAIN POWER APPLIED. IF ADJUSTMENTS ARE MADE WITH MAIN POWER APPLIED, AN INSULATED KB ADJUSTMENT TOOL MUST BE USED AND SAFETY GLASSES MUST BE WORN. HIGH VOLTAGE EXISTS IN THIS CONTROL. FIRE AND/OR ELECTROCUTION CAN RESULT IF CAUTION IS NOT EXERCISED. SAFETY WARNING, ON PAGE 5, MUST BE READ AND UNDERSTOOD BEFORE PROCEEDING.

10.1 Forward Acceleration (FACC) and Reverse Acceleration (RACC) – The FACC Trimpot determines the amount of time it takes the control voltage to reach full output in the forward direction. It also determines the amount of time it takes for the control voltage, in the reverse direction, to reach zero output (FACC is the Reverse Decel) See Figure 20A, on page 26.

The RACC Trimpot determines the amount of time it takes the control voltage to reach full output in the reverse direction. It also determines the amount of time it takes the control voltage, in the forward direction, to reach zero output to decelerate in the reverse direction (FACC = Reverse Deceleration).

The FACC and RACC Trimpots are factory set to 1 second. The acceleration times are adjustable to a maximum of 15 seconds (RACC is the forward Decel) See Figure 20B, on page 26.

Notes: The FCL and RCL Trimpot settings may override the rapid accel and decel settings.

**FIGURE 20A –
FORWARD AND REVERSE
ACCELERATION TRIMPOT POSITIONS**

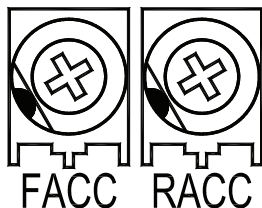

**FIGURE 20B – ACCEL TRIMPOT
ADJUSTMENT**

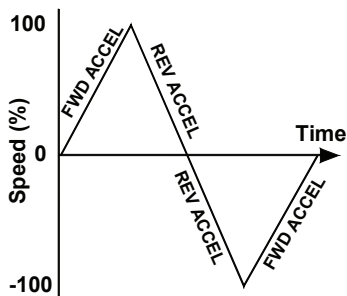

- 10.2 Maximum Speed (MAX)** - The MAX Trimpot is used to set the maximum output voltage of the control which, in turn, sets the maximum speed of the motor. The MAX Trimpot is factory set to 100% of base speed. In the Torque Control Mode, the MAX Trimpot setting determines the unloaded motor speed. See Figure 21.

Adjust the MAX Trimpot as follows:

- Rotate Main Speed Potentiometer to full speed (CW).
- Adjust MAX trimpot to desired maximum motor speed.

Note: Do not exceed maximum rated RPM of motor since unstable operation may result.

- 10.3 Forward Current Limit (FCL) and Reverse Current Limit (RCL) Trimpots** - These trimpots are used to set the maximum amount of DC current that the motor can draw in both the forward and reverse directions. The amount of DC current determines the amount of maximum motor torque in both the Speed Control Mode and Torque Control Mode. They are factory set to 150% of the current established by the jumper J2 position. See Figures 22A and 22B, on page 27.

Readjust the CL trimpots as follows:

- Turn CL trimpot to MIN (CCW) position. Be sure jumper J2 is in proper position approximately equal to the motor DC ampere rating.
- Connect a DC ammeter in series with armature lead. Lock shaft of motor.

**FIGURE 21 –MAXIMUM SPEED
TRIMPOT POSITION**



- c. Apply power; Rotate CL trimpot CW until desired CL setting is reached (factory setting is 1.5 times rated motor current). Be sure control is in Forward direction for FCL trimpot adjustment and likewise with RCL.



WARNING! DO NOT LEAVE MOTOR SHAFT LOCKED FOR MORE THAN 2 - 3 SECONDS, TO PREVENT MOTOR DAMAGE.

CAUTION: Adjusting the CL above 150% of motor rating can cause overheating and demagnetization of some PM motors. Consult motor manufacturer.

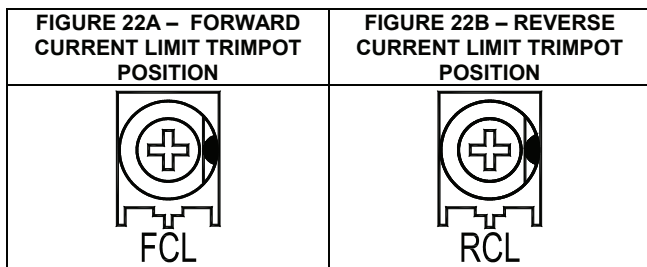

10.4 IR Compensation (IR Comp) - The IR Comp is used to stabilize motor speed under varying loads. The IR Trimpot is factory set to 5 Volts DC, with 115 Volt AC line input, and 10 Volts DC, with 208/230 Volt AC line input. See Figure 23.

If control is in Tach Feedback mode, the IR Comp should be set to minimum -CCW.

Note: Too much IR Comp will cause unstable (oscillatory) operation.

Readjust the IR Comp trimpot as follows:

- Run motor at approximately 30-50% of rated speed under no load and measure actual speed.
- Load motor to rated current. Rotate IR Comp trimpot so that loaded speed is the same as the unloaded speed measured in the previous step.

Control is now compensated so that minimal speed change will occur over a wide range of motor load.

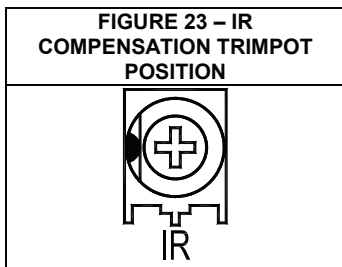

10.5 Response (RESP) - This trimpot determines the dynamic response of the control. The factory setting is approximately 50% of full rotation. The setting may be increased if a faster response is required. See Figure 24.

Note: If response is made too fast, unstable operation may result.

10.6 Deadband (DB) - The DB trimpot sets the amount of Main Speed Potentiometer rotation required to initiate control voltage output. The DB Trimpot is factory set to 0%. See Figures 25A and 25B.

FIGURE 24 –RESPONSE TRIMPOT POSITION



FIGURE 25A – DEADBAND TRIMPOT POSITION



FIGURE 25B – DEADBAND TRIMPOT ADJUSTMENT

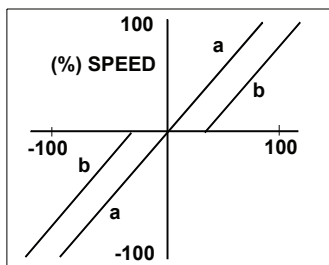

Curve (a): No Deadband
Curve (b): Max. Deadband

The DB trimpot also determines the amount of delay that will occur before regeneration starts. (Regeneration occurs when the applied load torque is in the same direction as the motor rotation).

To readjust the DB to factory setting:

- Set Main Speed pot to zero speed position.
- Set DB trimpot to full CCW position.
- Adjust DB trimpot CW until motor hum is eliminated.

Note: If the deadband trimpot is set too low (CCW direction), the motor may oscillate between forward and reverse. Adjust deadband trimpot CW until the instability disappears. (Oscillation may also occur due to response setting). See Sections 10.5 and 10.6.

10.7 Offset (OFFSET) - This trimpot determines the amount of bias in the forward or reverse direction. The trimpot is factory set to provide approximately zero offset, which means neither the forward nor the reverse speed is favored. See Figures 26A and 26B.

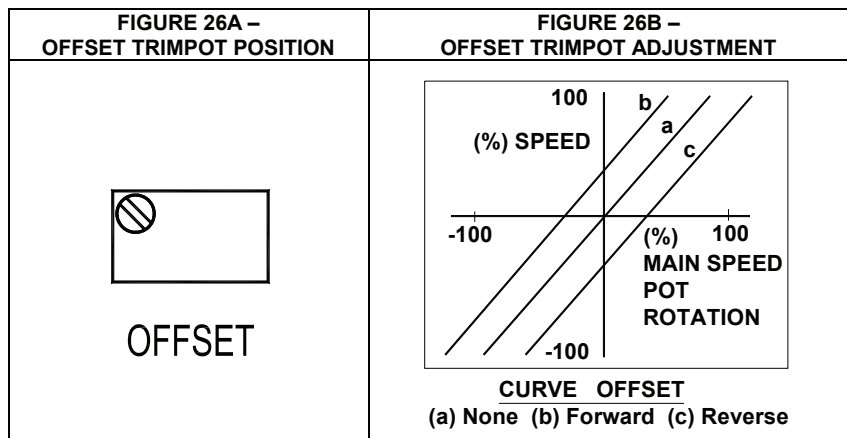

10.8 Scale (SCALE) – The Scale potentiometer is used in conjunction with jumper J8 (Section 7.5, on page 22) and the MAX Trimpot (Section 10.2, on page 26). This allows for fine adjustments of the analog input signal within the 0 – 10V or 0 – 15V ranges. In addition, the trimpot has an adjustment range of ± 5 to ± 25 V. See Figures 27A and 27B.

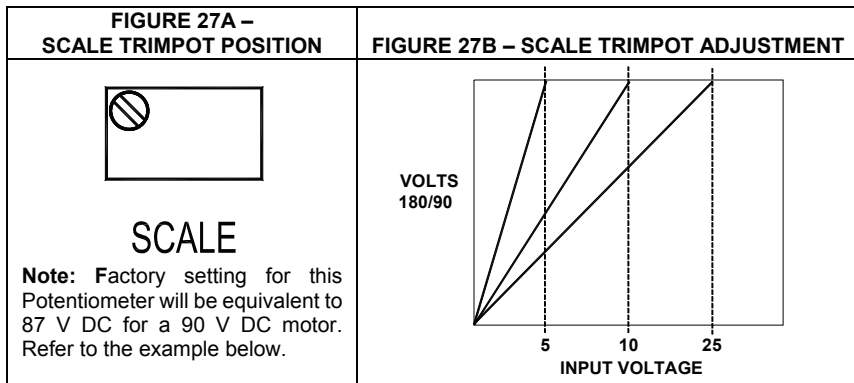

Example: Using a 90 V DC motor, and with jumper J8 to the 10V position. Adjust the Main Speed Potentiometer (Section 6.8, on page 16) to maximum clockwise (CW) position. At this point, the motor will be running at full speed. Adjust the SCALE trimpot, 3 turns in a counter-clockwise (CCW) position, until the voltmeter reads approximately 87 V DC (Production voltage setup).

11 DIAGNOSTIC LEDES

The KBRG-212D is designed with LEDs mounted on the Control Board, to indicate the control's operational status. See Figure 1, on page 10.

11.1 LED 1 Power On (PWR ON) -Indicates that the drive is energized with the AC line.

11.2 LED 2 Current Overload (OL) - Indicates that the drive is in Current Overload.

12 TROUBLESHOOTING



WARNING! HIGH VOLTAGE IS PRESENT IN THIS DRIVE. DISCONNECT MAIN POWER BEFORE MAKING CONNECTIONS TO THE DRIVE. THE COVER MUST BE PROPERLY SECURED, AFTER ALL SETUP CONNECTIONS, AND ADJUSTMENTS ARE COMPLETE. THIS REDUCES ELECTRICAL SHOCK HAZARD. FAILURE TO OBSERVE THIS WARNING COULD RESULT IN ELECTRICAL SHOCK OR ELECTROCUTION.



WARNING! HIGH VOLTAGE IS PRESENT IN THE DRIVE. IF POSSIBLE, DO NOT ADJUST TRIMPOTS WITH THE MAIN POWER APPLIED. IF ADJUSTMENTS ARE MADE WITH THE MAIN POWER APPLIED, AN INSULATED ADJUSTMENT TOOL (PROVIDED) MUST BE USED AND SAFETY GLASSES MUST BE WORN. FIRE AND/OR ELECTROCUTION CAN RESULT IF CAUTION IS NOT EXERCISED.

12.1 TROUBLESHOOTING GUIDE: Table 11, provides information on symptoms, possible causes, and the suggested troubleshooting solutions for the drive. See Section 11 for information on LED status indicators.

TABLE 11– TROUBLESHOOTING GUIDE

Indication / Symptom	Possible Solutions
Motor is not running and Power On LED indicator is illuminated.	The Main Speed Potentiometer is set to zero speed. Set the Main Speed Potentiometer for the desired speed.
	The Main Speed Potentiometer, signal input, or motor connections are open. Verify Main Speed Potentiometer, signal input, or motor connections.
Power ON LED indicator is not illuminated.	Check to see if the AC Line connections have been made.
Line fuse blows or circuit breaker trips.	Check AC Line fuse.
	The line fuse or circuit breaker installed is the incorrect rating. See Table 5, on page 8, for the correct line fuse or circuit breaker rating.
Troubleshooting continued on the following page.	

Troubleshooting (Continued)

OL LED indicator is illuminated.

Motor is overloaded. Check motor amps with DC ammeter in series with armature. (If motor is shunt type, field may be open or not receiving proper voltage.)

Check motor for shorts or grounds. Motor may be defective.

Check position of RCL and FCL trimpots. The trimpots may be set too low.

Rapid Acceleration change will cause the LED to illuminate. Verify potentiometer setting.

Note: For any other problems, consult the factory representative.

LIMITED WARRANTY

For a period of 18 months from the date of original purchase, KB Electronics, Inc. will repair or replace without charge, devices which our examination proves to be defective in material or workmanship. This warranty is valid if the unit has not been tampered with by unauthorized persons, misused, abused, or improperly installed and has been used in accordance with the instructions and/or ratings supplied. The foregoing is in lieu of any other warranty or guarantee, expressed or implied. KB Electronics, Inc. is not responsible for any expense, including installation and removal, inconvenience, or consequential damage, including injury to any person, caused by items of our manufacture or sale. Some states do not allow certain exclusions or limitations found in this warranty and therefore they may not apply to you. In any event, the total liability of KB Electronics, Inc. under any circumstance shall not exceed the full purchase price of this product. (rev 2/2000)

COPYRIGHT © 2009 KB Electronics, Inc.

All rights reserved. In accordance with the United States Copyright Act of 1976, no part of this publication may be reproduced in any form or by any means without permission in writing from KB Electronics, Inc. (8/2002)



KB Electronics, Inc.

12095 NW 39 Street, Coral Springs, FL 33065-2516

Phone: 954-346-4900; Fax: 954-346-3377, Outside Florida call Toll Free: 800-221-6570

e-mail: info@kbelectronics.com

www.kbelectronics.com