

TRIMLINE AIR-COOLED PANEL-MOUNTED AIR CONDITIONERS



DESCRIPTION

Innovations in technology have resulted in much denser components packaging and smaller available panel sizes on which to mount air conditioners. The KOOLTRONIC *TrimLine Series* is the response to these new packaging demands with the *Narrow* 10", 12", 15" and 17" width panel-mount air conditioners. In addition to being narrower than traditional air conditioner units, the *TrimLine Series* include the Condensate Evaporator, Low Temperature Control Thermostat and EMI/RFI Suppressor as *standard* features and are available in all popular voltages and frequencies.

The *TrimLine Series* consists of compact models in 2,000-2,500 BTU/H capacities, mid-size models 28", 33" and 36" with up to 4,000, 5,000 and 6,000 BTU/H respectively, the full-size 47" with 7,000, 10,000 and 13,000 BTU/H and 59" with 16,000 BTU/H. Each model series is designed with a minimum width to take up less cabinet space on the exterior panel or door.

Integral to the *TrimLine Series* is the *M/TAB* (Mounting Template and Assembly Bracket) system which makes installing KOOLTRONIC Air Conditioners simple and fast and interchangeable with corresponding *TrimLine Heat Exchangers*.

Outdoor or corrosive environments require weather protection and/or special internal and external protective features. Also see *Advantage Indoor/Outdoor*, *Integrity NEMA 4/4X* and *Intrepid Outdoor Series*.

For extreme ambient temperatures and/or severely contaminated environments, the use of *Water-Cooled Air Conditioners* or *Water-Cooled Heat Exchangers* is recommended.

General specifications common to all KOOLTRONIC Air Conditioners are on the first page of this section.

KOOLTRONIC also designs and manufactures a variety of air conditioners to meet *unique* specifications. We invite your inquiries about our modification and custom-design capabilities.

TRIMLINE

STANDARD FEATURES

- CFC-free or Low ODP Refrigerant
- All models UL/CUL Listed or Recognized
- NEMA 12 Rating maintained (UL50)
- Compact design with slim 10", 12", 15" and 17" wide mounting footprints
- Field-reversible condenser outlet blower on NP33, NP36, NP47 and NP59
- Exclusive KOOLTRONIC M/TAB mounting system
- Built-in Condensate Evaporator
- Thermostatic Low Temperature Control
- EMI/RFI Suppressor
- Heavy-duty steel enclosures with baked powder finish
- Six foot [1.8m] (minimum) SJT 3-wire power cord

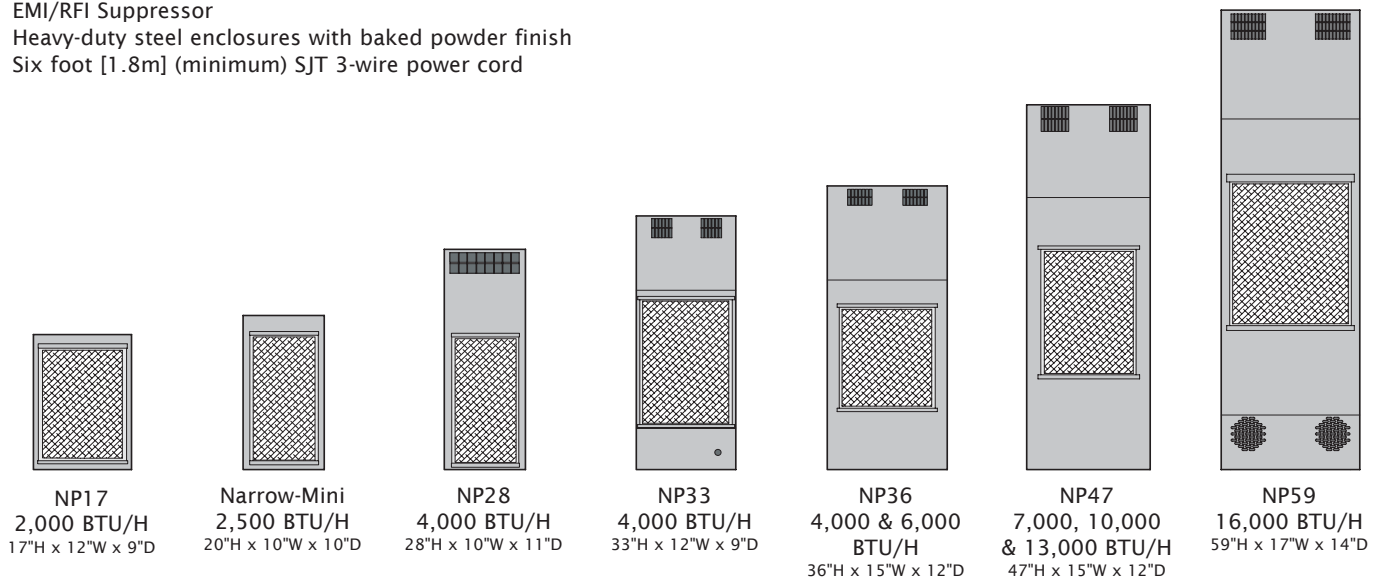



TECHNICAL DATA

Model	Normally in Stock	** BTU/H Capacity	95/95 Rating BTU/H	Ambient Temp. °F Max./Min.	Volts	Hz	** Running Amps	Approx. Weight (lbs.)
KA4C2.5NML	Yes	2500	2000	120/50	115/100	60/50	7.1	53
KA4C2.5NML56		2500	2000	120/50	115 [†]	50/60*	7.1	53
K2A4C2.5NML	Yes	2500	2000	125/50	230/200	60/50	3.6	53
K2A4C2.5NML5		2500	2000	120/50	230	50	3.1	53

ACCESSORIES AND OPTIONS

- Cooling Effect Detector
- Filters
- Filter Recoating Adhesive
- High-Capacity Condensate Evaporator
- Internal Corrosion Protection
- Lead-Lag Controller
- Lifting Eyes
- Low Ambient Kit
- Remote Thermostat Relay
- Short Cycle Protector
- Special controls or indicators
- Special materials or finishes
- Special motors, line cords, or connectors
- Stainless or Aluminum Shell
- Weather Protection Kit

STANDARD FEATURES

- Built-in Condensate Evaporator
- CFC-Free Refrigerant
- EMI/RFI Suppressor
- Low Temperature Control Thermostat
- M/TAB Mounting System
- NEMA12 Rating Maintained (UL50)
- UL/CUL Listed



PERFORMANCE

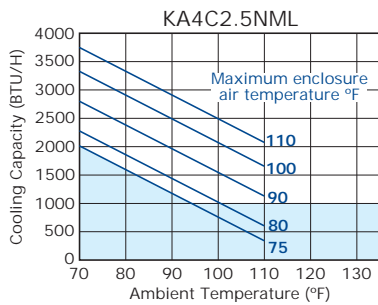

Operation within shaded area not recommended.

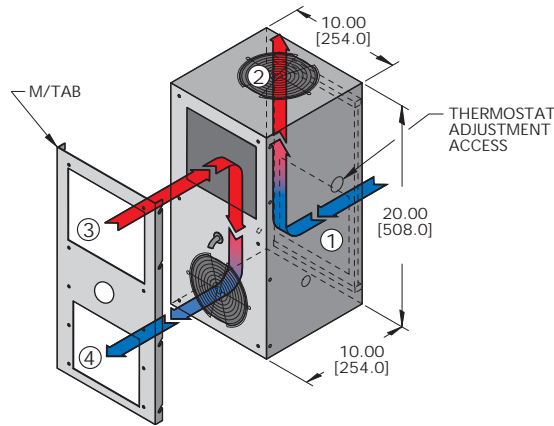

- ① FILTERED CONDENSER AIR INLET (Ambient Air In)
- ② CONDENSER OUTLET (Warm Ambient Air Out)
- ③ WARM AIR RETURN FROM ENCLOSURE
- ④ COOL AIR OUTLET TO ENCLOSURE

Weld nuts supplied for alternate mounting method to maintain NEMA 12. Mounting Plans furnished on request.

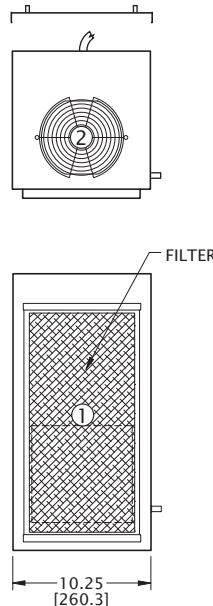
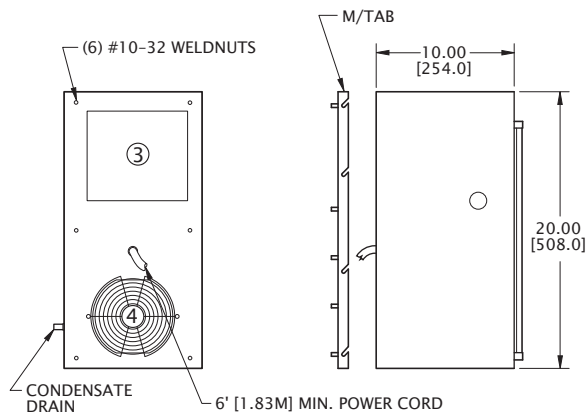

MOUNTING PLAN

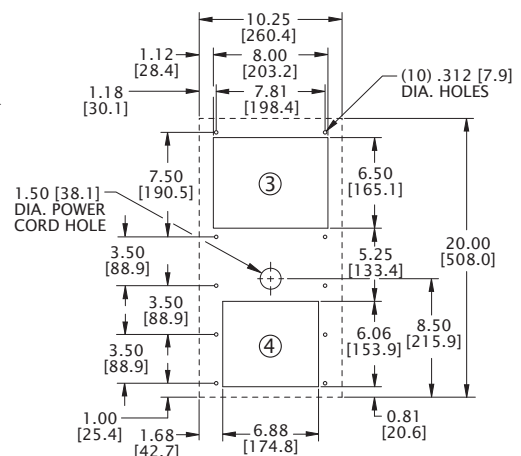

Dimensions, inches [mm], are for reference only and subject to change.

† The transformer required to reduce 115 volt supply to 100 volts for 50 Hz compressor operation is externally mounted. Consult KOOLTRONIC for resulting dimensional changes.

* Switchable. Switch is internally-mounted for security.

** Rating shown is for operation at maximum ambient temperature.

DESCRIPTION

Innovations in technology have resulted in much denser components packaging and smaller available panel sizes on which to mount Air Conditioners. The KOOLTRONIC *TrimLine Series* is the response to these new packaging demands with the Narrow 10", 12", 15", 17" and 21" width panel-mount air conditioners. In addition to being narrower than traditional Air Conditioner units, the *TrimLine Series* include the Condensate Evaporator, Low Temperature Control Thermostat and EMI/RFI Suppressor as *standard* features and are available in all popular voltages and frequencies.

The *TrimLine Narrow-Mini Series* consists of compact models in 1,000-2,500 BTU/H capacities. This series is designed with a minimum width to take up less cabinet space on the exterior panel or door.

Integral to the TrimLine Series is the M/TAB (Mounting Template and Assembly Bracket) system which makes installing KOOLTRONIC Air Conditioners simple and fast and interchangeable with corresponding TrimLine Heat Exchangers.

Outdoor or corrosive environments require weather protection and/or special internal and external protective features. Also see Integrity NEMA 4/4X and Intrepid Outdoor Series.

For extreme ambient temperatures and/or severely contaminated environments, the use of *TrimLine* or other **Water-Cooled Air Conditioners** is recommended.

KOOLTRONIC also designs and manufactures a variety of Air Conditioners to meet *unique* specifications. We invite your inquiries about our modification and custom-design capabilities.

STANDARD FEATURES

CLOSED-LOOP COOLING: The enclosure interior airflow system is isolated from the ambient airflow system. Ambient air can not invade the cool, dehumidified sensitive component compartment.

BALL-BEARING MOTORS: All fan motors are UL/CSA Recognized and include automatic-reset thermal overload protection and double-sealed or double-shielded precision ball bearings. Special permanent lubricants in the tube axial fans perform over a broad temperature range: -20°F [-28.9°C] to 250°F [121.1°C].

RUGGED CONSTRUCTION: Precision-engineered heavy gauge steel construction of all shells and blowers insures Air Conditioners will stand up under tough applications.

BAKED POWDER FINISH: Durable, baked-on gray powder finish is standard. Other finishes are available.

POWER: Available in 115 VAC, 60 Hz or 50/60 switchable and 230 VAC, 50 Hz or 60 Hz.

REFRIGERANT: CFC-free R134a Refrigerant is used in all *TrimLine Narrow-Mini* Series Air Conditioners.

PERMANENT FILTERS: Multi-layer grid of sturdy, corrugated aluminum in an aluminum frame. May be reused after washing off accumulations and spraying with A-16 Recoating Adhesive.

CONDENSATE EVAPORATOR: Built-in Condensate Evaporator eliminates need for draining condensate under normal operating conditions. May not be adequate in extremely high humidity with open or leaky enclosure. Overflow condensate drain fitting and hose are included.

LOW TEMPERATURE CONTROL: Thermostatic Low Temperature Control prevents over-cooling and provides energy-efficient operation.

EMI/RFI SUPPRESSOR: EMI/RFI Suppressor minimizes transient line spikes during on/off cycling.

POWER CORD: All models have six foot [1.8m] SJT-type 3-wire power cords with appropriate plugs.

INSULATION: All cold components, lines and the evaporator compartment are insulated with high-performance insulation for maximum efficiency.

GASKETING: All units are fully gasketed for tight, leakproof installation, in compliance with the NEMA 12 Enclosure Rating. (Weld nuts are supplied for mounting method to maintain NEMA 12, M/TAB is not required.)

QUALITY ASSURANCE: Refrigeration system components are kept sealed until charged with refrigerant; all brazed joints are thoroughly leak-tested; each unit is functionally tested before shipment.

INSTALLATION: Detailed Installation and Operator's Manual, with drawings, mounting plan and spare parts list is included with each unit.

UL/CUL LISTED: All *TrimLine Narrow-Mini Series* are **UL/CUL Listed**.

ACCESSORIES AND OPTIONS**

FACTORY-INSTALLED OPTIONS:

ALUMINUM SHELL: Where light weight and/or compatibility with appearance of Aluminum Enclosures are required. Unpainted Type 5052 is standard. Other types and ultra-violet-resistant baked powder finish are available.

Append letter "A" to Part No. (5052 Unpainted)

COOLING EFFECT DETECTOR: A thermostat is mounted inside the cabinet and attached to a sensor in the warm air return. When the air temperature increases to the set point, a signal is sent to a terminal block. User-installed wiring from the terminal block to local and/or remote warning devices (*light, bell, siren, etc.*) can be for normally open or closed operation.

Append letter "B" to Part No.

INTERNAL CORROSION PROTECTION: For corrosive or other hostile environments, special coating material is applied to copper lines, coils and other parts subject to damage. Also see **Stainless Steel Shell** or **Integrity NEMA 4/4X Air Conditioners**.

Append letter "H" to Part No.

****Contact KOOLTRONIC for information.**

ACCESSORIES AND OPTIONS** (continued)

LIFTING EYES: Heavy-gauge steel lifting eyes, attached to the side panels, assist in positioning units.

Append letter "K" to Part No.

LOW AMBIENT KIT: Maintains sufficient operating pressures when ambient temperatures drop below 50°F [10°C]. Includes a compressor heater and pressure actuated condenser blower cycling control.

Append letter "N" to Part No.

SHORT CYCLE PROTECTOR: Protects the compressor from possible damage due to harmful short cycling, by initiating an "off" period before resumption of normal operation. Generally air conditioners require several minutes off for compressor protection after power interruptions of any type. These power interruptions can include power failures, opening of interlocked access doors, and cases where a thermostat activates the compressor in less than a few minutes. This option is particularly recommended for applications where frequent, brief power failures occur, interlocked cabinet doors are utilized, or where the cabinet internal loads fluctuate across a wide range.

Append letter "Y" to Part No.

SPECIAL MATERIALS OR FINISHES**

SPECIAL MOTORS, LINE CORDS OR CONNECTORS**

STAINLESS STEEL SHELL: For applications in corrosive or other hostile environments such as those requiring Internal Corrosion Resistant Coatings, especially where chemical/moisture combinations are present.

Append letter "V" to Part No. (304-2B Unpainted)

CUSTOMER-INSTALLED OPTIONS:

FILTERS FOR REPLACEMENT: All KOOLTRONIC filters consist of a multi-layer grid of sturdy corrugated aluminum, securely held in a one-piece aluminum frame. Filters are required wherever air is drawn into an electronics enclosure or related cooling equipment to keep internal parts as clean as possible.

A non-drying adhesive coating traps a high percentage of particulate matter. These washable, reusable filters are designed to last the life of the cooling unit. Replacements are available for those which become damaged or otherwise non-serviceable.

Part No. 8751F (16.63" x 8.38" x 0.50" [422mm x 213mm x 13mm])

FILTER RECOATING ADHESIVE: This compound is a superior product for recoating all permanent filters after washing. The adhesives penetrate dirt layers to keep the filter surface tacky for longer effective performance between washings.

Part No. A-16 - one pint container.

WEATHER PROTECTION KIT: For outdoor installations subject to invasion by rain, snow or windblown dirt, special deflectors shield the condenser air inlet and outlet ports. Air conditioners installed outdoors may also require special exterior paint.

**Contact KOOLTRONIC for information.

HOW TO ORDER

Specify model number. NOTE: Accessories and Options may affect model number, contact KOOLTRONIC for information.

For assistance in model selection, refer to the Air Conditioner Sizing and Selection Guide, contact KOOLTRONIC, or use one of our design aid software programs, available FREE.

CALL 1-800-321-KOOL (5665)
or FAX 609-466-1114

**POPULAR MODELS ARE
STOCKED AND READY TO SHIP**