

PRODUCT INFORMATION PACKET



Model No: C6T17NK2K

Catalog No: 110670.00

1/2HP..1725RPM.56.TENV.208-230/460V.3PH.60HZ.CONT.NOT.40C.1.15SF.RIGID
C.BRAKEMOTORS.C6T17NK2K

Brake



Regal and Leeson are trademarks of Regal Beloit Corporation or one of its affiliated companies.

©2018 Regal Beloit Corporation, All Rights Reserved. MC017097E





Nameplate Specifications

Output HP	0.50 Hp	Output KW	0.37 kW
Frequency	60 Hz	Voltage	208-230/460 V
Current	2.0-1.8/0.90 A	Speed	1725 rpm
Service Factor	1.15	Phase	3
Efficiency	78.5 %	Duty	Continuous
Insulation Class	B	Design Code	B
KVA Code	L	Frame	56C
Enclosure	Totally Enclosed Non Ventilated	Overload Protector	No
Ambient Temperature	40 °C	Drive End Bearing Size	6203
Opp Drive End Bearing Size	6203	UL	Recognized
CSA	Y	CE	N
IP Code	43		

Technical Specifications

Electrical Type	Squirrel Cage Induction Run	Starting Method	Across The Line
Poles	4	Rotation	Reversible
Mounting	Rigid base	Motor Orientation	HORIZONTAL
Drive End Bearing	BALL	Opp Drive End Bearing	BALL
Frame Material	Rolled Steel	Shaft Type	NEMA 56
Overall Length	14.06 in	Frame Length	5.50 in
Shaft Diameter	0.625 in	Shaft Extension	1.88 in
Assembly/Box Mounting	F1 ONLY		
Outline Drawing	028534-550	Connection Diagram	005010.15

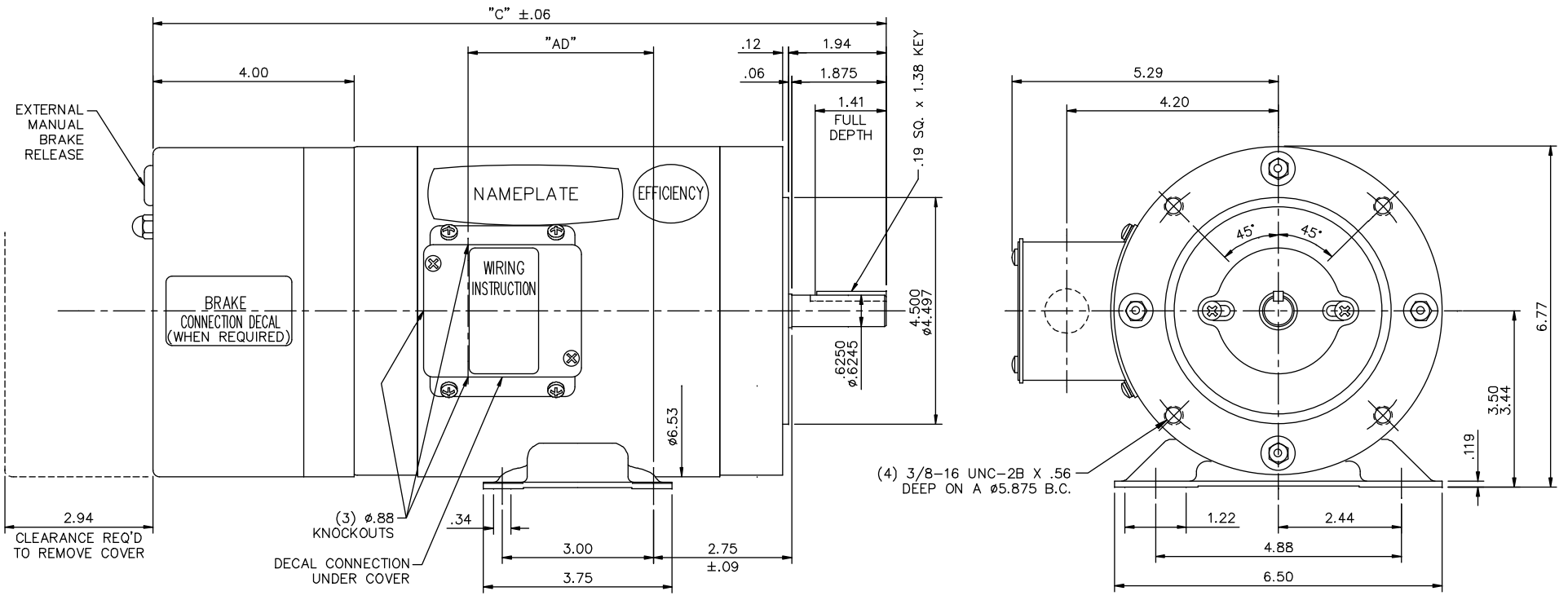

DASH NO.	"C"	"AD"
500	13.56	2.68
550	14.06	3.18
600	14.56	3.68
650	15.06	4.18

MAXIMUM FACE RUNOUT .004 T.I.R.
 MAXIMUM PILOT ECCENTRICITY .004 T.I.R.
 PERMISSIBLE SHAFT RUNOUT .002 T.I.R.

GASKETS THROUGHOUT

		TOLERANCES UNLESS SPECIFIED		TITLE	DRAWN R/LW 06/12/03
		DEC.	INCHES		
		.X	±.1	LEESON ELECTRIC MOTORS GEARMOTORS AND DRIVES OUTLINE 56 FRAME T.E.N.V. - RIGID "C"	CHK
		.XX	±.03		APPD
		.XXX	±.005		SCALE 1=2
		.XXXX	±.0005		REF
01	ADDED BRAKE DECAL	ARV	8/20/13	MAT'L. BRAKEMOTOR	FMF
NO.	REVISION	BY & DATE	CHK ANG	FINISH	PREV
THIS DRAWING IN DESIGN AND DETAIL IS OUR PROPERTY AND MUST NOT BE USED EXCEPT IN CONNECTION WITH OUR WORK ALL RIGHTS OF DESIGN AND INVENTION ARE RESERVED THIS IS AN ELECTRONICALLY GENERATED DOCUMENT - DO NOT SCALE THIS PRINT				RFP CAD FILE 028534	SIZE B
				DIST	DRAWING NO. 028534
					REV. 01

VIEW FROM OUTSIDE OF MOTOR AT SWITCH END.



CAUTION:
LEAD WIRE INSULATION TO EXTEND
MINIMUM OF 1/4" INTO CONNECTOR
INSULATION

SEE TABLE FOR
 BRAKE CONNECTIONS

REF. DECAL (MOTOR) - 004014
 REF. DECAL (BRAKE) - 080034 (STEARNS & DINGS BRAKE)

LINE LEADS

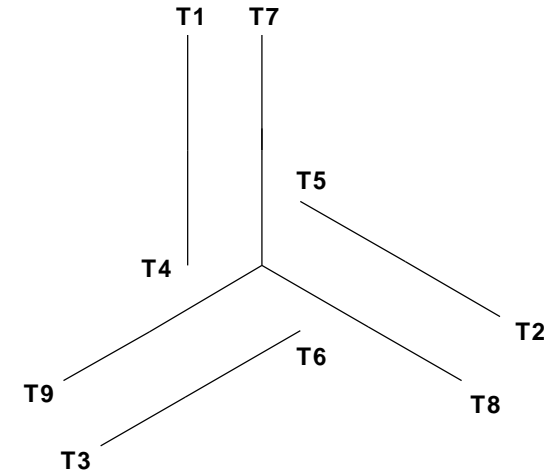

VOLTAGE	L1	L2	L3	JOIN & INSULATE
HIGH	T1	T2	T3	(T4, T7) (T5, T8) (T6, T9)
LOW	T1, T7	T2, T8	T3, T9	T4, T5, T6

RBC PROPRIETARY AND CONFIDENTIAL INFORMATION
 This document is the property of REGAL BELOIT CORPORATION ("RBC") including its subsidiaries and divisions and contains proprietary information of RBC. This document is loaned on the express condition that neither it nor the information contained therein shall be disclosed to others without the express written consent of RBC, and that the information shall be used by the recipient only as approved expressly by RBC. This document shall be returned to RBC upon its request. This document may be subject to certain restrictions under U.S. export control laws and regulations.

TYPE "T" W/O PROTECTOR

VOLTAGE	BRAKE CONNECTION					
	STEARNS BRAKE			DINGS BRAKE		
	L1	L2	Join	L1	L2	Join
HIGH	1(RED)	2(RED)	3(BLACK) 4(BLACK)	2(BLACK)	4(YELLOW)	1(YELLOW) 3(BLACK)
LOW	1(RED) 3(BLACK)	2(RED) 4(BLACK)	-----	2(BLACK) 3(BLACK)	1(YELLOW) 4(YELLOW)	-----

				TOLERANCES UNLESS SPECIFIED		ELECTRIC MOTORS GEARMOTORS AND DRIVES	DRAWN JJK 09/17/96	
				DEC	INCHES		CHK	
				.X	±.1	APPR		
				.XX	±.01	SCALE 1:1		
--	REDRAWN IN SOLIDWORKS	VJB 02/08/11	.XXX	±.005	TITLE EXTERNAL WIRING DIAGRAM STANDARD 3 PHASE - DUAL VOLTAGE		REF 005010-01	
01	ADDED DINGS AND BRAKE TABLE (PER CN114156)	TMZ 11/12/96	.XXXX	±.0005	MAT'L W/STEARNS OR DINGS DUAL VOLTAGE BRAKE CONN.		FMF	
NO	REVISION	BY & DATE	CHK	ANG	±1/2°	FINISH LEESON STOCK		PAGE OF
THIRD ANGLE PROJECTION				RFP	PREV	SIZE	DRAWING NO	REV
				NETWORK FILE NAME 00501015		A	005010-15	--



Motor Load Data						
Load	0%	25%	50%	75%	100%	LR
Current (Amps)	0.65	0.71	0.76	0.84	0.90	12.2
Torque (ft-lb)	0.00	96.0	192	288	384	1,153
RPM	1800	1788	1776	1764	1750	0
Efficiency (%)		57.7	70.1	75.2	78.5	77.0
P.F. (%)	13.1	29.2	44.6	56.0	67.0	69.0

Motor Speed Data						Information Block																					
LR	Pull-Up	BD	Rated	Idle		HP	Sync. RPM	Frame	Enclosure	Construction	Voltage	Frequency	Design	LR Code letter	Service Factor	Temp Rise @ FL	Duty	Ambient	Elevation	Rotor/Shaft wk ²	Ref Wdg	Sound Pressure @ 1M	VFD Rating	Outline Dwg	Conn. Diag	Additional Specifications:	
0	300	1310	1750	1800		0.5	1800	140	TENV	TTR	208-230/460	60	A	L	1.15	70	CONT	40	1,000	0.06	T634208 NR	0	dB(A)	NONE	028534-550	005010.15	
Current (Amps)	12.2	5.7	4.5	0.90	0.55																						
Torque (ft-lb)	1,153	1,142	1,564	384	0.00																						

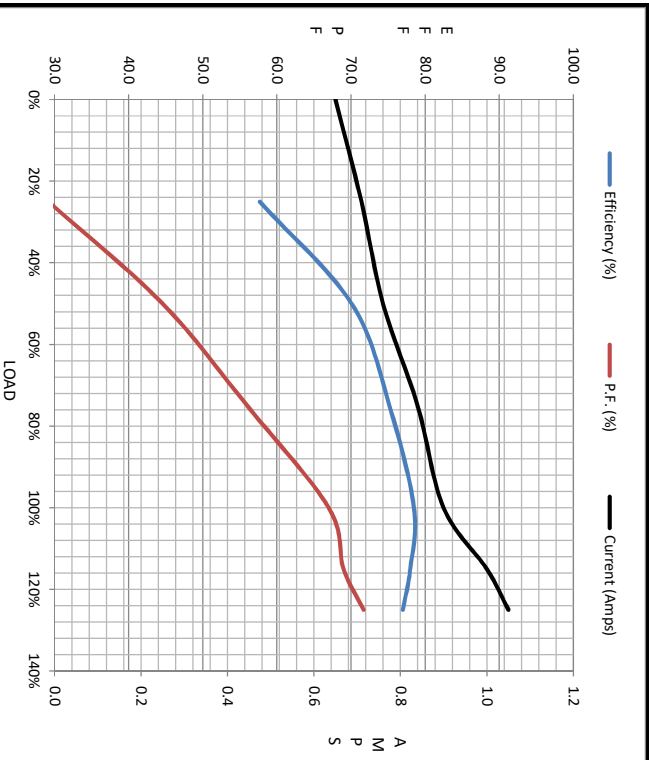

R1	R2	X1	X2	Xm
0.0000	0.0000	0.0000	0.0000	0.0000

